

Industrial gas meter with M-Bus for compressed air, natural gas, biogas...

Compressed air and natural gas meters with M-Bus now also directly from the manufacturer.

- Modbus RTU
- Modbus TCP or TCP PoE
- Profibus, Profinet
- 4..20 mA and pulse
- Hard (in preparation)

M-Bus

The IVA 520, IVA 500, IVA 550 and IVA 570 industrial gas meters with M-Bus are the ideal compressed air meters or consumption meters for natural gas, biogas, methane, nitrogen, argon, carbon dioxide for consumption measurement and flow measurement.

VA 520, VA 500, VA 550, VA 570 with M-Bus are ideal for conversion or retrofitting and for new installations of gas meters, compressed air meters, flow meters, etc. to existing or new energy management software according to DIN ISO 50001 and DIN ISO 16247 and building management systems.



Advantages:

- Direct display in Nm³/h, or NI/min and temperature in C°
- Calorimetric measuring principle - no additional pressure and temperature measurement necessary
- High measurement accuracy ¼ to 3 inches
- IVA 500 and IVA 550 insert version from ½ inch to DN 400 / DN 500

IVA 520 Compressed air meter with M-Bus



4...20 mA output for actual flow

Pulse output for total flow (counter reading), galvanically isolated or M-Bus (optionally)

Measuring device removable:
Dismounting of the whole measuring section is not necessary, no bypass required

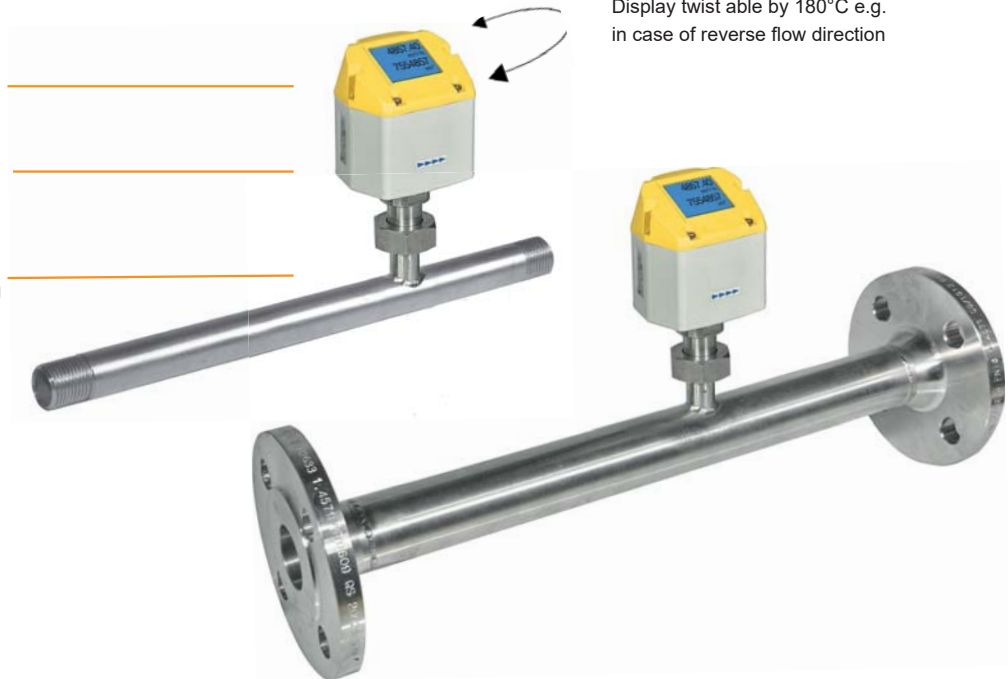

Display twist able by 180°C e.g. in case of reverse flow direction

Easy installation into the existing pipeline due to integrated measuring section and welding neck according to (EN 1092-1 PN 40)

High measuring accuracy due to defined measuring section (inlet and outlet section)



Display shows two values at the same time:

- Actual flow in m³/h, l/min...
- Total consumption(counter reading) in m³, l
- resp. temperature measurement

Values indicated in the display turnable by 180°C, e. g. in case of overhead installation

At the touch of a button

- Reset of counter reading
- selection of units
- zero-point adjustment, leak flow volume suppression

Intelligent solutions for accurate flow measurement for compressed air and gases

The new affordable flow sensors VA 520 work according to the approved calorimetric measuring principle. An additional pressure and temperature compensation is not necessary. Contrary to the previously used bridge circuit the newly developed evaluation electronics records all measured values digitally. This enables very precise and fast measurements.

Due to the new evaluation electronics all IVA 520 have an integrated Modbus output as a standard. So all parameters

can be transferred via Modbus.

Due to its compact design it is possible to monitor all compressed air systems from the compressor to the smallest compressed air tool (1/4" to 3 inch) with the new affordable flow sensor VA 520.

VA500 flow sensors are available for larger pipe diameters from DN 50 to DN 1000. Apart from compressed air also other gases like e.g. nitrogen, oxygen and CO2 can be measured.

Application range of IVA 520:

- Compressed air balancing, compressed air consumption measurement
- Leakage air/leak rate determination
- Mobile compressed air measurement in front of single machines / plants
- Flow measurement of process gases like e.g. nitrogen, CO2, oxygen, argon, nitrous oxide
- Flow measurement at nitrogen generators

IVA 520 with M-Bus

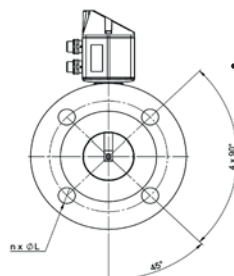
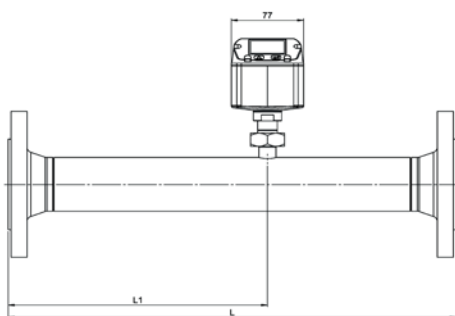
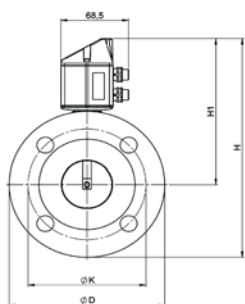

- Flange version DIN EN 1092-1

Flow measuring ranges IVA 520 for compressed air (ISO 1217:1000 mbar, 20 °C)

Anschluss-gewinde	AD Rohr mm	ID Rohr mm	Messbereich von bis	L mm	L1 mm	H mm	H1 mm
R 1/4"	13,7	8,9	0,8 90 l/min	194	137	174,7	165,7
R 1/2"	21,3	16,1	0,2 90 m³/h	300	210	176,4	165,7
R 3/4"	26,9	21,7	0,3 170 m³/h	475	275	179,2	165,7
R 1"	33,7	27,3	0,5 290 m³/h	475	275	182,6	165,7
R 1 1/4"	42,4	36,0	0,7 530 m³/h	475	275	186,9	165,7
R 1 1/2"	48,3	41,9	1,0 730 m³/h	475*	275	186,9	165,7
R 2"	60,3	53,1	2,0 1195 m³/h	475*	275	195,9	165,7
DN 65	76,1	68,9	4,0 2050 m³/h	475*	275	268,2	175,7
DN 80	88,9	80,9	5,0 2840 m³/h	475*	275	275,7	175,7

*Attention: Shorted inlet section! Please observe the recommended minimum inlet section (length = 15 x inner diameter) on site

Description	Order no. Flansch DIN EN 1092-1	Order no. Stainless steel 1.4571	Order no. Stainless steel 1.4301
VA 520 flow sensor with integrated 1/4" measuring section	-	0695 1520	0695 0520
VA 520 flow sensor with integrated 1/2" measuring section	0695 2521	0695 1521	0695 0521
VA 520 flow sensor with integrated 3/4" measuring section	0695 2522	0695 1522	0695 0522
VA 520 flow sensor with integrated 1" measuring section	0695 2523	0695 1523	0695 0523
VA 520 flow sensor with integrated 1 1/4" measuring section	0695 2526	0695 1526	0695 0526
VA 520 flow sensor with integrated 1 1/2" measuring section	0695 2524	0695 1524	0695 0524
VA 520 flow sensor with integrated 2" measuring section	0695 2525	0695 1525	0695 0525
VA 520 flow sensor with integrated 2 1/2" measuring section	0695 2527	-	-
VA 520 flow sensor with integrated 3" measuring section	0695 2528	-	-
Option High-pressure version PN 40			Z695 0411
Option 1 % Accuracy of m.v. ± 0,3 % of f.s.			Z695 5005
Special measuring range IVA 520			Z695 4006
Ethernet-Interface for VA500/520 and FA500			Z695 5006
Ethernet-Interface PoE for VA500/520 and FA500			Z695 5007
M-Bus board for VA500/520 and FA500			Z695 5004
Connection cables:			
Connection cable for IVA/IFA serie, 5 m			0553 0104
Connection cable for IVA/IFA serie, 10 m			0553 0105
Pulse cable for flow sensors with M12 plug, length 5 m			0553 0106
Pulse cable for flow sensors with M12 plug, length 10 m			0553 0107
Further accessories:			
Closing cap for IVA 520 (Material: Aluminium)			0190 0001
Closing cap for IVA 520 (Material: Stainless steel 1.404)			0190 0002
ICS Service Software for IFA/IVA sensors incl. PC connection set, USB interface and interface adapter to the sensor			0554 2007
Mains unit in wall housing for maximum 2 sensors of the series VA/FA 5xx, 100-240 V, 23 VA, 50-60 Hz / 24 VDC, 0.35 A			0554 0110
AC adapter plug 100-240 V AC / 24 V for IVA/IFA 5xx			0554 0109
5 point precision calibration with ISO certificate			3200 0001
M12 – T plug for IVA 500/520 to connect several sensors to a M-Bus network or Modbus network.			020000823

Technical data

IVA 520

Parameters:	m³/h, l/min (1000 mbar, 20 °C) in case of compressed air resp. Nm³/h, NI/min (1013 mbar, 0 °C) in case of gases
Units adjustable via keys at display:	m³/h, m³/min, l/min, l/s, ft/min, cfm, m/s, kg/h, kg/min
Meas. principle:	calorimetric measurement
Sensor:	Thermal mass flow sensor
Meas. medium:	air, gases
Gas types adjustable via external device DS 400, DS 500, PI 500	air, nitrogen, argon, nitrous oxide, CO2, oxygen
Meas. range:	see table at the left
Accuracy: (m.v.: of meas. value) (f.s.: of full scale)	± 1.5 % of m.v. ± 0.3 % of f.s. on request ± 1.0 % of m.v. ± 0.3 % of f.s.
Operating temp.:	-30...80 °C
Operating pressure:	up to 16 bar optional up to PN 40
Digital output:	RS 485 interface, Modbus-RTU, M-Bus (optionally)
Analogue output:	4...20 mA for m³/h resp. l/min
Pulse output:	1 pulse per m³ resp. per liter galvanically separated Pulse value on Display adjustable
Power supply:	18...36 VDC, 5 W
Burden:	< 500 Ω
Housing:	polycarbonate
Meas. section:	stainless steel, 1.4301 or 1.4571
Mounting thread meas. section:	R 1/4", R 1/2", R 3/4", R 1", R 1 1/4", R 1 1/2", R 2" external thread

IVA 570 with M-Bus and integrated measuring section



IVA 570 is supplied with an integrated measuring section. The measuring sections are available in flanged version or with R resp. NPT thread.

A special feature is the removable measuring head. So the measuring unit can be removed easily and quickly for calibration or cleaning purposes without having to dismantle the measuring section intricately. During this period the measuring section is sealed by a closing cap (accessory).

Flow measuring ranges IVA 570

Inch	Inner pipe diameter (mm)	DN	Full scale values in Nm ³ /h					Methane natural gas (CH ₄)
			Air	N ₂	Ar	O ₂	CO ₂	
R 1/2"	16.1	DN 15	0.2...90	0.2...80	0.2...140	0.2...85	0.2...90	0.2...50
R 3/4"	21.7	DN 20	0.3...170	0.3...155	0.3...275	0.3...165	0.3...175	0.3...105
R 1"	27.3	DN 25	0.5...290	0.5...260	0.5...460	0.5...280	0.5...290	0.5...170
R 1 1/4"	36.0	DN 32	0.7...530	0.7...485	0.7...830	0.7...505	0.7...525	0.7...310
R 1 1/2"	41.9	DN 40	1.0...730	1.0...650	1.0...1140	1.0...695	1.0...720	1.0...430
R 2"	53.1	DN 50	2.0...1195	2.0...1060	2.0...1870	2.0...1140	2.0...1185	2.0...705
	68.9	DN 65	4.0...2050	3.0...1820	6.0...3205	3.0...1955	4.0...2030	2.0...1210
	80.9	DN 80	5.0...2840	5.0...2610	9.0...4440	5.0...2710	5.0...2810	3.0...1680

If you want to measure the flow of a special gas mixture please contact us. On request we are quite pleased to offer a real gas calibration under process conditions.

Measuring ranges of further gases like: Nitrous oxide (N₂O), helium (He), propane (C₃H₈), biogas* (CH₄/CO₂ 60/40) on request!



Measuring head removable



Screwing with centring device

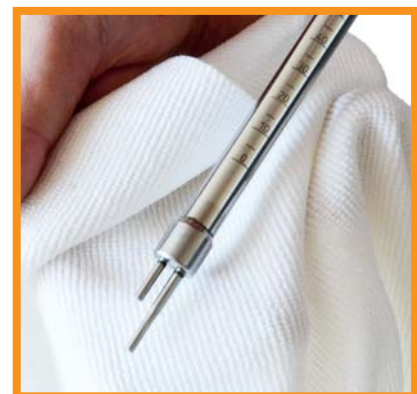

Easy cleaning of the sensor system

IVA 570 with M-Bus

Präzise Verbrauchs-/Durchflussmessung für Druckluft und Gase

The new flow sensors VA 550/ 570 work according to the calorimetric measuring principle. Therefore an additional temperature and pressure compensation is not necessary.

Due to its robust design, the aluminum die cast housing, the robust sensor tip made from stainless steel 1,4571, the new IVA 550/ 570 are suitable for demanding industrial applications. An ATEX version is available for applications in explosive areas. For flow measurement e. g. of natural gas there is a version with a DVGW admission.

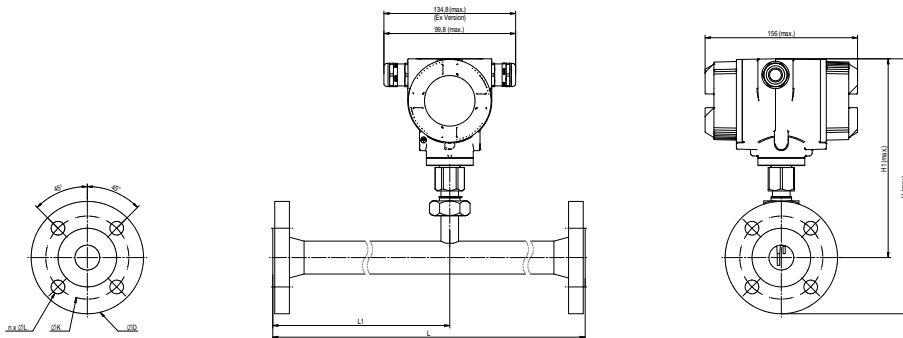

*Technical data see IVA 500

Application range:

- Ideal also for the outdoor area
- Compressed air measurement and distribution
- Leakage measurement of compressed air and gases
- Flow measurement of gases like e. g. nitrogen, argon, carbon dioxide, oxygen and so on
- Flow measurement in vacuum systems
- Flow measurement of explosive gases like natural gas, methane, propane, hydrogen with ATEX approval
- Flow measurement of corrosive, acid gases like e. g. biogas with different gas mixtures
- Measurement of oxygen and natural gas at gas burners
- Flow measurement of gas mixtures like e. g. forming gas

Applicable in all sectors like e. g.:

- Chemistry, petrol chemistry
- Natural gas, methane...
- Pharmaceutical industry
- Food production
- Breweries
- Diaries
- Power plants
- Semiconductor/ electronics
- Automotive industry

IVA 570 - with M-Bus										
Measuring section	Outer pipe daim. mm	Inner pipe diam. mm	L mm	L1 mm	H mm	H1 mm	Flange DIN EN 1092-1			Thread
							Ø D	Ø K	n x Ø L	A mm
DN 15	21,3	16,1	300	210	213,2	165,7	95	65	4 x 14	20
DN 20	26,9	21,7	475	275	218,2	165,7	105	75	4 x 14	20
DN 25	33,7	27,3	475	275	223,2	165,7	115	85	4 x 14	25
DN 32	42,4	36,0	475	275	235,7	165,7	140	100	4 x 18	25
DN 40	48,3	41,9	475*	275	240,7	165,7	150	110	4 x 18	25
DN 50	60,3	53,1	475*	275	248,2	165,7	165	125	4 x 18	30
DN 65	76,1	68,9	475*	275	268,2	175,7	185	145	8 x 18	-
DN 80	88,9	80,9	475*	275	275,7	175,7	200	160	8 x 18	-

*Attention: Shortened inlet section! Please observe the recommended minimum inlet section (length = 15x inner diameter)

Description	Order no.	Order no. Thread
VA 570 flow sensor with integrated DN 15 measuring section	0695 2570	0695 0570
VA 570 flow sensor with integrated DN 20 measuring section	0695 2571	0695 0571
VA 570 flow sensor with integrated DN 25 measuring section	0695 2572	0695 0572
VA 570 flow sensor with integrated DN 32 measuring section	0695 2573	0695 0573
VA 570 flow sensor with integrated DN 40 measuring section	0695 2574	0695 0574
VA 570 flow sensor with integrated DN 50 measuring section	0695 2575	0695 0575
VA 570 flow sensor with integrated DN 65 measuring section	0695 2576	0695 0576
VA 570 flow sensor with integrated DN 80 measuring section	0695 2577	0695 0577

What are the advantages of our flow measuring technology?

1) Even under pressure, the flow sensor IVA 500 is mounted by means of a standard 1/2" ball valve. During mounting and dismounting the safety ring avoids an uncontrolled ejection of the probe which may be caused by the operating pressure.

For the mounting into different pipe diameters IVA 500 is available in the following probe lengths: 120, 160, 220, 300, 400 mm.

So the flow sensors are being mounted into existing pipelines with inner diameters of 1/2" upwards.

The exact positioning of the sensor in the middle of the pipe is granted by means of the engraved depth scale. The maximum mounting depth corresponds with the respective probe length. Example: IVA 500 with probe length 220 mm has a maximum mounting depth of 220 mm.

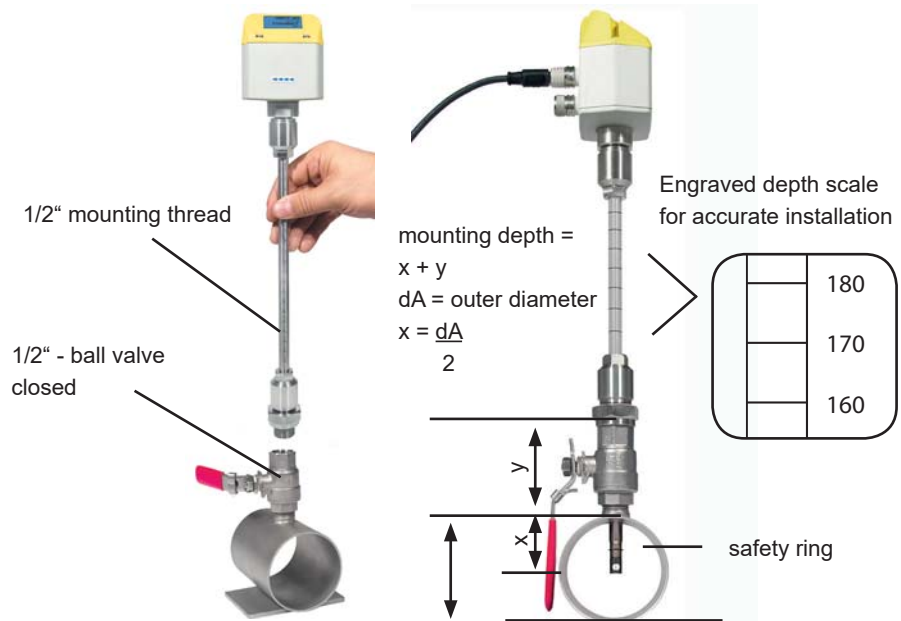

2) If there is no suitable measuring site with a 1/2" ball valve present there are two simple possibilities to set up a measuring point:

A Weld on a 1/2" screw neck and screw on a 1/2" ball valve

B Mount spot drilling collar incl. ball valve (see accessories)

By means of the drilling jig it is possible to drill under pressure through the 1/2" ball valve into the existing pipeline. The drilling chips are collected in a filter. Then the probe can be mounted as described under point 1.)



A Screw neck



B Spot drilling collar



Drilling under pressure

Flow measuring ranges IVA 500 for compressed air (ISO 1217:1000 mbar, 20 °C)					
Inner diameter of pipe			IVA 500 Standard (92.7 m/s)	IVA 500 Max. (185.0 m/s)	IVA 500 High-Speed (224.0 m/s)
Inch	mm		Measuring range from to	Measuring range from to	Measuring range from to
1/2"	16.1	DN 15	2.5...760 l/min	3.5...1516 l/min	6.0...1836 l/min
3/4"	21.7	DN 20	0.3...89 m³/h	0.4...178 m³/h	0.7...215 m³/h
1"	27.3	DN 25	0.5...148 m³/h	0.6...295 m³/h	1.1...357 m³/h
1 1/4"	36.0	DN 32	0.9...280 m³/h	1.2...531 m³/h	2.5...644 m³/h
1 1/2"	41.9	DN 40	1.2...366 m³/h	1.5...732 m³/h	3.0...886 m³/h
2"	53.1	DN 50	2...600 m³/h	2.5...1198 m³/h	4.6...1450 m³/h
2 1/2"	71.1	DN 65	3.5...1096 m³/h	5...2187 m³/h	7...2648 m³/h
3"	84.9	DN 80	5...1570 m³/h	7...3133 m³/h	12...3794 m³/h
4"	110.0	DN 100	9...2645 m³/h	12...5279 m³/h	16...6391 m³/h
5"	133.7	DN 125	13...3912 m³/h	18...7808 m³/h	24...9453 m³/h
6"	159.3	DN 150	18...5560 m³/h	25...11097 m³/h	43...13436 m³/h
8"	200.0	DN 200	26...8786 m³/h	33...17533 m³/h	50...21230 m³/h
10"	250.0	DN 250	40...13744 m³/h	52...27429 m³/h	80...33211 m³/h
12"	300.0	DN 300	60...19815 m³/h	80...39544 m³/h	100...47881 m³/h

3) Due to the large measuring range of the probe even extreme requirements to the consumption measurement (high volume flow in small pipe diameters) can be met. The measuring range is depending on the pipe diameter - see table on the right hand side.

IVA 500 - with M-Bus

Flow sensor for compressed air and gases

The new VA 500 for flow measurement of compressed air and gases, optionally with display for flow in m³/h and total flow in m³.

Contrary to the previously used bridge circuit the newly developed evaluation electronics records all measured values digitally. This leads to a better accuracy also in case of large measuring spans of 1:1000.

Special features:

- RS 485 interface, Modbus-RTU as a standard
- Incl. temperature measurement
- Integrated display for m³/h and m³
- Usable from 1/2" to DN 1000
- Easy installation under pressure
- 4...20 mA analogue output for m³/h resp. m³/min
- Pulse output for m³ or M-Bus (optionally)
- Inner diameter adjustable via keypad
- Consumption counter resettable
- Adjustable via keys at the display: Reference conditions, °C and mbar, 4...20 mA scaling, pulse weight

flexible mounting
thread G 1/2"

safety ring
Ø 11.7 mm



Inner diameter adjustable
via keypad

Technical data IVA 500

Parameters: m³/h, l/min (1000 mbar, 20°C)
in case of compressed air resp.
Nm³/h, NI/min (1013 mbar, 0°C) in
case of gases

Units adjustable via keys at display: m³/h, m³/min, l/min, l/s, ft/min, cfm, m/s, kg/h, kg/min

Adjustable via keypad: diameter for volume flow calculation, counter resettable

Meas. principle: calorimetric measurement

Sensor: Thermal mass flow sensor

Meas. medium: air, gases

Gas types adjustable via external devices DS 400, DS 500, PI 500 air, nitrogen, argon, nitrous oxide, CO₂, oxygen

Meas. range: see table measuring ranges page 80

Accuracy: ± 1.5 % of m.v. ± 0.3 % of f.s. on request
(m.v.: of meas. value)
(f.s.: of full scale)
± 1.0 % of m.v. ± 0.3 % of f.s.

Operating temp.: -30...110 °C probe tube
-30...80 °C housing

Operating pressure: up to 50 bar

Digital output: RS 485 interface, Modbus RTU, M-Bus (optionally)

Analogue output: 4...20 mA for m³/h resp. l/min; on request: scaling for cfm, m³/min, l/min, l/s, ft/min, m/s

Pulse output: 1 pulse per m³ resp. per liter galvanically separated

Power supply: 18...36 VDC, 5 W

Burden: < 500 Ω

Housing: polycarbonate (IP 65)

Probe tube: stainless steel, 1.4301 mounting length 220 mm, Ø 10 mm

Mounting thread: G 1/2"

Ø Casing: 65 mm

Description	Order No.
VA 500 flow sensor in basic version: Standard (92.7 m/s), probe length 220 mm, without display	0695 5001
Options for IVA 500:	
Display	Z695 5000
Max. version (185 m/s)	Z695 5003
High Speed version (224 m/s)	Z695 5002
1 % Accuracy of m.v. ± 0,3 % of f.s.	Z695 5005
Ethernet-Interface for VA500/520 and FA500	Z695 5006
Ethernet-Interface PoE for VA500/520 and FA500	Z695 5007
M-Bus board for VA500/520 and FA500	Z695 5004
Probe length 120 mm	ZSL 0120
Probe length 160 mm	ZSL 0160
Probe length 300 mm	ZSL 0300
Probe length 400 mm	ZSL 0400
Probe length 500 mm	ZSL 0500
Probe length 600 mm	ZSL 0600
Connection cables:	
Connection cable, 5 m	0553 0104
Connection cable, 10 m	0553 0105
Further accessories:	
ICS Service Software for IFA/IVA 500 sensors incl. PC connection set, USB inter-face and interface adapter to the sensor	0554 2007
Mains unit in wall housing for maximum 2 sensors of the series IVA/IFA 5xx, 100-240 V, 23 VA, 50-60 Hz / 24 VDC, 0.35 A	0554 0110
AC adapter plug 100-240 V AC/ 24 V for IVA/IFA 500/520	0554 0109
External wall display chart recorder DS 400	0500 4000
5 point precision calibration with ISO certificate	3200 0001
M12 - T plug for IVA 500/520 to connect several sensors to a M-Bus network or Modbus network.	020000823

IVA 550 - with M-Bus

Flow sensor for heavy duty industrial applications incl. temperature measurement

M-Bus



Housing IP 67

Aluminum compressed gas for outdoor use

Outputs:

4...20 mA, pulse, Modbus, M-Bus, Profibus, Ethernet, HART

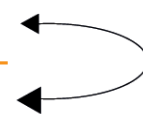

Housing twist able, display twist able by 180°

Engraved depth scale for accurate mounting

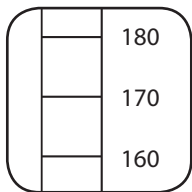

All medium-touching parts are made from stainless steel 1.4571



Measuring ranges flow VA 550 - immersion sensor

Inner diameter of pipe			Standard version (92.7 m/s)							Max. version (185.0 m/s)							High-Speed version (224.0 m/s)							Recommended sensor length
			Full scale values in Nm³/h *							Full scale values in Nm³/h *							Full scale values in Nm³/h *							
Inch	mm	DN	Air**	N2	Ar	O2	CO2	Methane nat. gas (CH4)	Air**	N2	Ar	O2	CO2	Methane nat. gas (CH4)	Air**	N2	Ar	O2	CO2	Methane nat. gas (CH4)				
1/2"	16.1	DN 15	45	40	71	43	45	26	90	80	142	86	90	53	110	98	172	105	109	65	160 mm			
3/4"	21.7	DN 20	89	79	139	85	88	52	177	158	278	169	176	105	215	191	336	205	213	127				
1"	27.3	DN 25	122	108	191	116	120	72	243	216	381	232	241	144	295	262	461	281	292	174				
1 1/4"	36.0	DN 32	266	236	416	254	263	157	531	472	830	506	526	314	643	572	1006	613	636	380				
1 1/2"	41.9	DN 40	366	324	570	348	361	215	728	647	1138	694	720	430	881	784	1378	841	872	521	220 mm			
2"	53.1	DN 50	600	533	938	572	593	354	1197	1064	1872	1141	1185	708	1450	1289	2267	1382	1434	857				
2 1/2"	71.1	DN 65	1095	974	1712	1044	1083	647	2186	1944	3418	2085	2164	1293	2647	2354	4139	2524	2619	1566				
3"	84.9	DN 80	1569	1395	2454	1497	1553	928	3133	2786	4897	2987	3101	1852	3793	3373	5931	3617	3753	2244				
4"	110.0	DN 100	2644	2351	4134	2522	2616	1563	5278	4693	8251	5033	5224	3121	6391	5683	9992	6094	6322	3780	300 mm			
5"	133.7	DN 125	3921	3477	6115	3730	3870	2312	7807	6942	12205	7444	7727	4617	9453	8406	14779	9014	9352	5591				
6"	159.3	DN 150	5579	4942	8691	5302	5500	3287	11096	9867	17347	10581	10982	6562	13436	11948	21006	12812	13292	7947				
8"	200.0	DN 200	8816	7809	13733	8378	8690	5193	17533	15590	27409	16718	17353	10368	21229	18879	33190	20244	21002	12557				
10"	250.0	DN 250	13742	12216	21483	13106	13595	8124	27428	24389	42877	26153	27147	16220	33211	29534	51921	31669	32855	19644				
12"	300.0	DN 300	19836	17613	30972	18895	19601	11713	39544	35162	61817	37706	39138	23384	47880	42579	74856	45657	47367	28322				

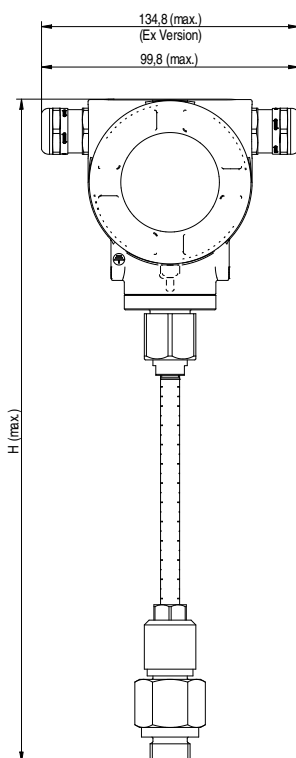

Available with option:
Ethernet Modbus/TCP



Application range:

- Ideal also for the outdoor area
- Compressed air measurement and distribution
- Leakage measurement of compressed air and gases
- Flow measurement of gases like e. g. nitrogen, argon, carbon dioxide, oxygen and so on
- Flow measurement in vacuum systems
- Flow measurement of explosive gases like natural gas, methane, propane, hydrogen with ATEX approval
- Flow measurement of corrosive, acid gases like e. g. biogas with different gas mixtures
- Measurement of oxygen and natural gas at gas burners
- Flow measurement of gas mixtures like e. g. forming gas

Applicable in all sectors like e. g.:

- Chemistry, petrol chemistry
- Natural gas, methane...
- Pharmaceutical industry
- Food production
- Breweries
- Diaries
- Power plants
- Semiconductor/ electronics
- Automotive industry

Technical data IVA 550/ 570

Measuring range	0.1...92,7 Nm/s, standard version* 0.1...185 Nm/s, max. version* 0.1...224 Nm/s, high speed version*
Accuracy: accuracy class (m.v.: of meas. value) (f.s.: of full scale)	± 1.5 % of m.v. ± 0.3 % of f.s. <u>on request</u> ± 1.0 % of m.v. ± 0.3 % of f.s.
Accuracy indications	referred to ambient temperature 22°C ± 2°C, system pressure 6 bar
Repeatability:	0.25 % of m.v. in case of correct mounting (mounting aid, position, inlet section)
Measuring principle:	Thermal mass flow sensor, the measuring effect is based on the cooling down of a heated sensor PT 45 by bypassing gas. The ambient temperature is measured with a PT 100. An additional pressure and temperature compensation is not necessary.
Response time:	t90 < 3 s
Operating temperature range probe tube/display unit:	-40...180 °C probe tube -40...70°C display unit -40...120°C for ATEX version
Adjustment possibilities via display, external hand-held meter PI 500, PC Service Software, remote diagnosis:	Nm³/h, Nm³/min, Nl/min, l/s, ft/min, cfm, kg/h, kg/min, inner diameter, reference conditions °C/°F, mbar/hPa, zero-point correction, leak flow volume suppression, scaling of analogue output 4...20 mA, pulse/alarm, error codes and so on
Adjustment possibilities via external device DS 400, DS 500 or PI 500	Gas type: air, nitrogen, CO2...
Outputs:	<u>Standard:</u> Modbus RTU, 4...20 mA activ (not galv. isolated), galvanically isolated pulse (pulse weight freely selectable), alarm relais (max. 48 VDC, 0.5A) <u>Optional:</u> 2 x 4...20 mA outputs galvanically isolated, Ethernet Interface (Modbus/TCP), Profibus DP, Profinet, 2 x 4...20 mA outputs passive, M-Bus
Burden:	500 Ohm
Additional average value calculation:	for all parameters freely adjustable from 1 minute up to 1 day, e. g. 1/2 hours average value, average day value
Protection class :	IP 67
Material:	Housing aluminium die cast, probe tube stainless steel 1,4571
Screw-in thread:	G 1/2" ISO 228, NPT 1/2", R 1/2", PT 1/2" available
Operating pressure IVA 550:	50 bar; in special version 100 bar (For DVGW approval max. 16 bar)
Operating pressure IVA 570:	16 bar; in special version 40 bar
Power supply:	18...36 VDC, 5 W
Approval:	ATEX II 2G Ex d IIC T4, DVGW

Description	Order no.
VA 550 flow sensor, measuring head in robust aluminium die cast housing - Request order code	0695 0550

Industrial gas meter with M-Bus interface



The M-Bus (meter bus) is a fieldbus and is used for consumption data acquisition and remote meter reading of consumption meters and gas meters for example for compressed air, natural gas, nitrogen, argon, CO₂ and other gases or for water, heat, cold, etc.

The M-Bus stands for the European standard Meter-Bus for the transmission of consumption values, meter readings and measurement data.

The M-Bus was originally described in the European standard EN 1434. The M-Bus has become an independent standard in the standard series EN 13757.

The M-Bus transmits data serially on a reverse polarity protected 2-wire line.

The M-Bus has gained market importance in measuring data acquisition and transmission. Especially for low-priced consumption meters and through the simple and reverse polarity safe installation of for example compressed air meters or gas meters, the M-Bus has prevailed in many companies.

This allows the IVA 520 M-Bus compressed air meter or IVA 500 M-Bus gas meter to be connected to an existing one M-Bus energy monitoring software or M-Bus energy management software or connect to M-Bus master.

The IVA 520 / IVA 500 with M-Bus is an M-Bus slave and is polled by the M-Bus master. It may only be one master in the bus system, otherwise addressing errors may occur.

The M-Bus is mainly interesting in the context of low-cost consumption-capture measurement in a building control system as part of an energy management system according to DIN ISO 5001 and DIN ISO 16247. The M-Bus interface is designed from 300 to 9600 baud (bit / s).

The maximum total power length depends on the cable cross-section and the cable-specific properties (resistance and capacity), the maximum cable length is 4000 m.

M-Bus advantages:

- With the M-Bus, all consumption meters can be connected to a central unit via a single polarity-protected cable (bus)
- All bus participants (electricity meters, compressed air meters, gas meters, consumption meters for compressed air and gases, etc.) are supplied directly via the two-wire bus.
- Devices from different manufacturers can be connected to a building system, so that the user is not bound to a meter manufacturer.