

Multifunction instrument with 1 input "Easy Connect" for 3 Rogowski probes

Code: **MK96R63DT – MK96R63MT**
MK96R125DT – MK96R125MT
Model: **NEMO 96 EC**

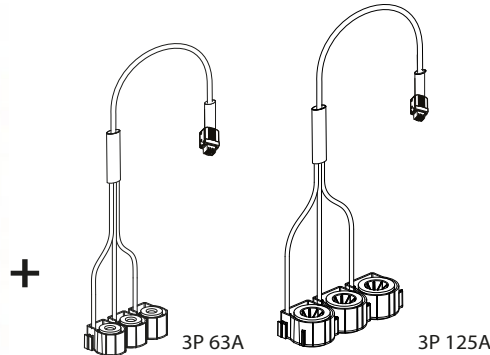

Contents	Pages
1. Use	1
2. Range	1
3. Installation	1
4. Dimensions	1
5. Connections	2
6. Operating data	3
7. General features	3
8. Conformity and certifications	5
9. Communication	6

1. USE

The multifunction instrument with 4 DIN modules measures in 4 dials (Active and Reactive energies, positive and negative). It has a quick connector for the connection of the Rogowski type current coil trio.

The instrument can be used in 3N3E networks, it has a diagnostic and phase sequence correction function.

2. RANGE

Code Art.	I _{max}	Output	Digital Inputs	Voltage Range	
MK96R63DT	63A	Modbus	2 Tariffs	3x230/ 3x400±15%	
MK96R125DT	125A				
MK96R63MT	63A	Mbus			
MK96R125MT	125A				
Cable code				Cable length (m)	Quantity
ROGETM1	-	-	-	1	x 3 max.
ROGETXM3	-	-	-	3	x 1 max.

3. INSTALLATION

Fixing:

On solid panel door, opening 92x92 mm

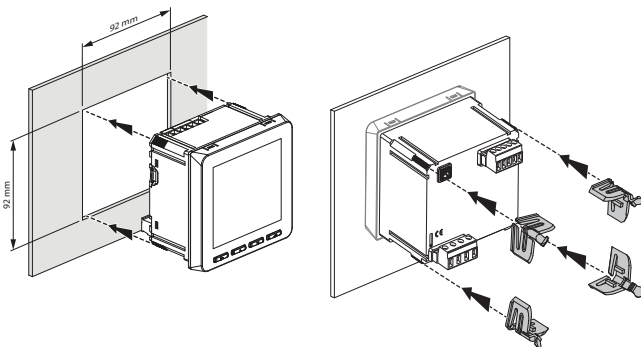

4. DIMENSIONS

Housing: flush mounting 96x96mm

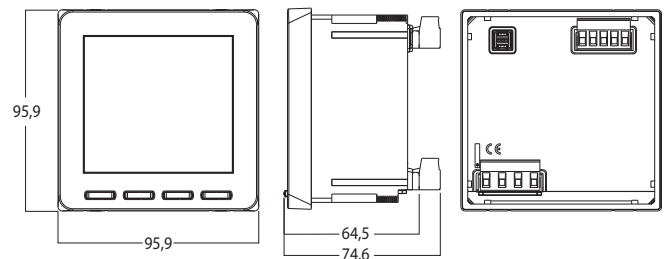

Rogowski 63A -125A

	Ø	A	B	C	D	E	F
63A	9	15	23,4	18	21,05	18	57,05
125A	15	15	28,4	26	29,05	26	84,05

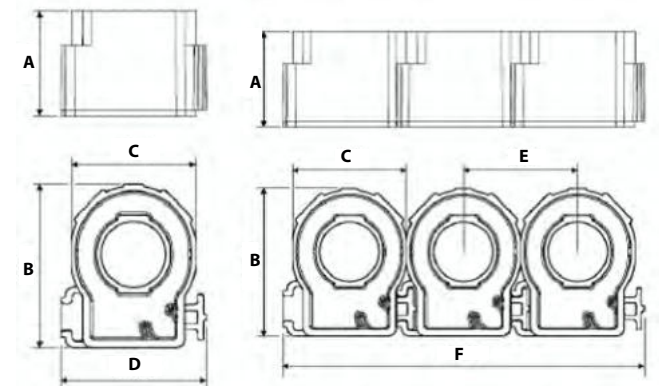

Multifunction instrument with 1 input "Easy Connect" for 3 Rogowski probes

Code: MK96R63DT – MK96R63MT
MK96R125DT – MK96R125MT

Model: NEMO 96 EC

6. OPERATING DATA

6.1 ELECTRIC DATA

Currents	MK96R63DT MK96R63MT	MK96R125DT MK96R125MT
Reference current	10A	20A
Min. current	0,5A	1A
Max. current	63A	125A

V1,V2,V3,N voltages :

- 3x230V / 3x400V ±15%

V1,V2,V3,N rated frequency:

- F_n : 50...60Hz

- Permitted variation : 45...65Hz

Self supplied :

- Rated frequency: 50/60Hz

- Operating frequency: 45...65Hz

- Self consumption: $\leq 2.5VA @230 Vac$

Connectable section:

Terminals	Without bush	With bush
Rigid wire	0,05 + 2,5 mm ²	0,05 + 1,5 mm ²
Flexible wire	0,05 + 1,5 mm ²	0,05 + 1 mm ²

Necessary tools:

- For all the terminals, use a 2.5mm slotted screwdriver and/or a PH0 screwdriver.

6.2 MECHANICAL DATA

Screw terminals:

- Max external dimensions: 18,5mm

- Lengths of the wire stripping: 6 / 7,5mm

Screw head:

- COMBI screws (slotted / Phillips head)

Recommended torque:

- For all the terminals: 0.5 Nm

7. GENERAL FEATURES (continues)

Front marking:

Indelible digital print.



Connection terminal board marking:

- by indelible tamppography

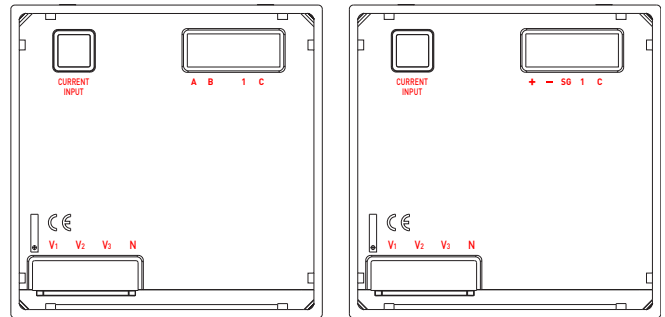

Display:

- Type: backlit liquid crystal display

- Reading points: 10,000 4 digits (digit height 12 mm)

- Energy measure: 8 digit meter (digit height 8 mm)

- Resolution: automatic

- Decimal point: automatic

- Update time: 1sec.

Display of the value and programming:

- By means of the front keypad, 4 pushbuttons (see the user manual).

- Access protected by identification code (**predefined code 1000**)

Measurements and precision in conformity with EN/IEC 61557-12

- Current: cl.1

- Voltage: cl.0.5

- Frequency: $\pm 0.1 Hz$

- Instantaneous total active power, phase, average value and max. average value: cl.1

- Instantaneous total reactive power, phase, average value and max. average value: cl.2

- Instantaneous total apparent power, phase, average value and max. average value: cl.1

- Power Factor: cl.1

- Total active energy, positive and negative: cl.1 EN/IEC 62053-21

- Total reactive energy, positive and negative: cl.2 EN/IEC 62053-23

- Energia attiva tariffaria: cl.1

The above classes are guaranteed by maintaining the centring, between Rogowski sensor and primary conductor, with the appropriate accessories provided and a harmonic content within the limits of the EN/IEC 61557-12 standard

Average power:

- Measurement: apparent, reactive, active power

- Calculation: moving average, on the selected period

- Average time: 5/8/10/15/20/30/60min.

Maximum dissipated thermal power for the thermal dimensioning of the panels: $\leq 5W$

Multifunction instrument with 1 input "Easy Connect" for 3 Rogowski probes

Code: MK96R63DT – MK96R63MT
MK96R125DT – MK96R125MT

Model: NEMO 96 EC

7. GENERAL FEATURES

Resettable meter:

- Counting of operating hours and minutes
- 7-figure resolution (5 for the hours + 2 for the minutes)
- Maximum display: 99999.99
- Programmable value: 0...50% Pn (Positive active power)

Harmonic analysis (THD):

- Up to the 15th harmonic

Digital input

- The digital input allows switching the energy counting on 2 tariffs
- Input terminals with common point (1-C)
- Rated voltage: 12 – 24V d.c., 10mA Max.

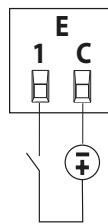

Features of the ModBus communication port:

- Programmable addresses: from 1 to 247 (5*)
- Communication speed: 4.8 – 9.6 – 19.2* – 38.4 kbps
- Parity bit: none, even*, odd
- Stop bit: 1
- Galvanically isolated with respect to the measurement inputs
- Standard RS485 3 wires, half-duplex
- Modbus® RTU protocol
- Response time (question/response time-out): ≤ 200ms
- 120Ω terminating resistor inside the instrument (it can be set in the SETUP menu, default value: none*)

Features of the MBus communication port:

- Standard: EN 13757
- Transmission: serial asynchronous
- No. of bit: 8
- Parity bit: fixed even
- Communication speed: 300-600-1.200-2.400*-4.800-9.600bit/s
- No. of primary address: 0*...250
- No. of secondary address: 0...99,999,999
- Load MBus: 1
- Galvanically isolated with respect to the measurement inputs
- Transferred measurements: see communication protocol

* Factory data

Diagnostic, Phase sequence correction:

On the device there is a diagnostic and correction algorithm of the voltmetric and amperometric connection sequence. The function can be activated on request and password protected: it can display and modify the wiring sequence with the following limitations:

- 1) The neutral conductor (in the 4-wire connections) must be correctly positioned (terminal 11)
- 2) The power factor must be between 0.9cap and 0.7ind for each phase. See www.imeitaly.com "TECHNICAL SUPPORT".

7. GENERAL FEATURES

Protection class:

- Terminal protection index against solid bodies and liquids: IP 20 (IEC/EN 60529).
- Housing front protection index against solid bodies and liquids: IP 54 (IEC/EN 60529).

Protection of the device:

- Fuse 0.5A type gG

Resistance to vibrations:

- Vibration: from 5 to 150Hz width 0,15mm/1g
- Shock: 19g / 16msec

Material:

Self-extinguishing Polycarbonate, reinforced 10% Glass fibre; Identification according to ISO 11469: >PC-GF10-FR<; GWFI IEC 60965-2-12 (§1.6mm): 960°C; Flame rating UL 94 / IEC 60695_11_10 (1.6/3.2 mm): V0;

Operating room temperatures:

- Min. = - 20 °C Max. = + 60 °C.

Room storage temperatures:

- Min. = - 25 °C Max. = + 70 °C

Weight: 0,550Kg (63A) – 0,580Kg (125A)

Packaged volume: 1,5 dm³

Room: mechanical M1 – electric E2

8. CONFORMITY AND CERTIFICATIONS

Insulation

- Measurement categories: III (according to EN-61010)
- Level of pollution: 2
- Insulation voltage, U_i : 300V, Phase-Neutral

Dielectric rigidity:

- Power supplies/ Outputs: 3kV / 50Hz / 1min
- Housing / Terminals: 4kV / 50Hz / 1min

Pulse:

- Power supplies: 6.3kV / 1.2 – 50µsec / 0.5J

In compliance with the standards:

- Precision class: Active energy class 1 (EN/IEC 62053-21)
- Precision class: Class 2 reactive energy (EN/IEC 62053-23)
- Electromagnetic compatibility: Tests in accordance with EN/IEC 62052-11 / EN 61326-1
- Precision class according to IEC/EN61557-12
- 2014/35/UE 2014/30/UE

Respecting the environment – Conformity with the CEE directives:

- Compliance with the 2100/65/EU Directive, as modified by the 2015/863 Directive (RoHS 2), on the restriction of the use of certain hazardous substances in electrical and electronic equipment.
- Conformity with the REACH Regulation (1907/ 2006): at the date of publication of this document no substance in the annex XIV is found in these products.
- RAEE Directive (2012/19/EU: the sale of this product includes a contribution to the appointed environmental bodies of each European country in charge of handling, at the end of their life, the products falling within the scope of the EU Directive on Electric and Electronic Equipment Waste.

Plastic materials:

- Plastic materials without Halogens.
- Part marking according to standards ISO 11469 and ISO 1043.

Packaging:

- Packaging designed and produced in accordance with Decree 98-638 of 20/07/1998 and directive 94/62/CE.

**Multifunction instrument with 1 input
"Easy Connect" for 3 Rogowski probes**

Code: MK96R63DT – MK96R63MT
MK96R125DT – MK96R125MT
Model: NEMO 96 EC

9. COMMUNICATION

RS485 Modbus wiring diagram:

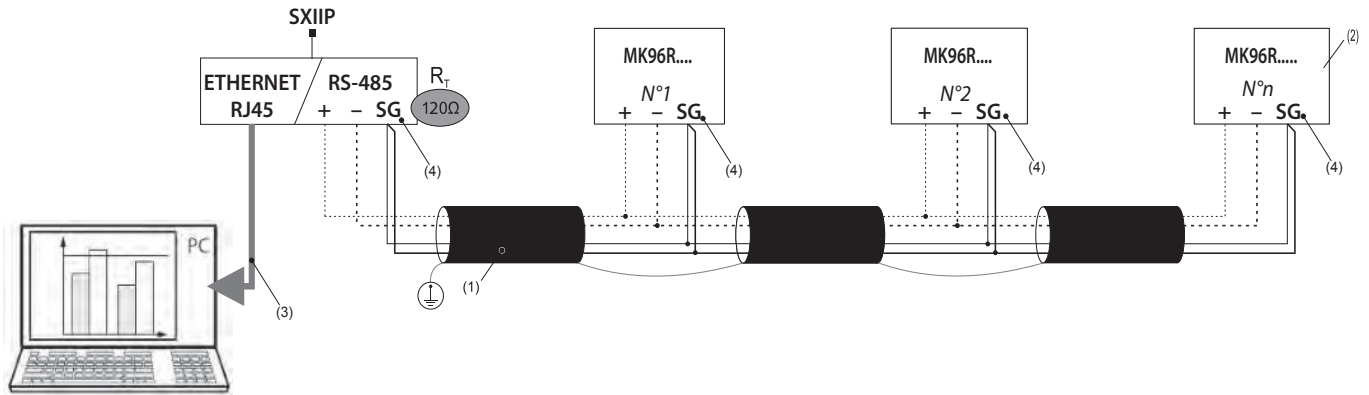

RS485 Modbus wiring diagram with Mini Web Server:

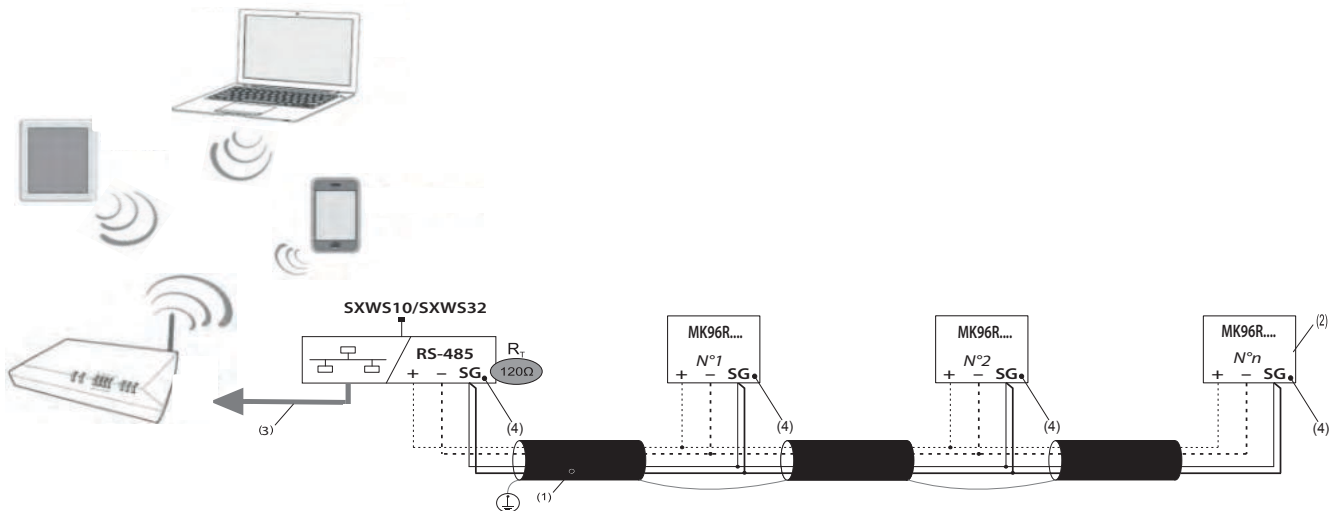

- (1) RS485: Required use of Belden 9842 or Belden 3106A wire (or equivalent) for a maximum bus length of 1000 m, or Category 6 wire (FTP or UTP) for a maximum length of 50 m
- (2) 120Ω terminating resistor inside the instrument (it can be set in the SETUP menu)
- (3) Ethernet: Cat. 6 (FTP/UTP)
- (4) The "SG" terminal must never be connected to the earth

Mbus wiring diagram:

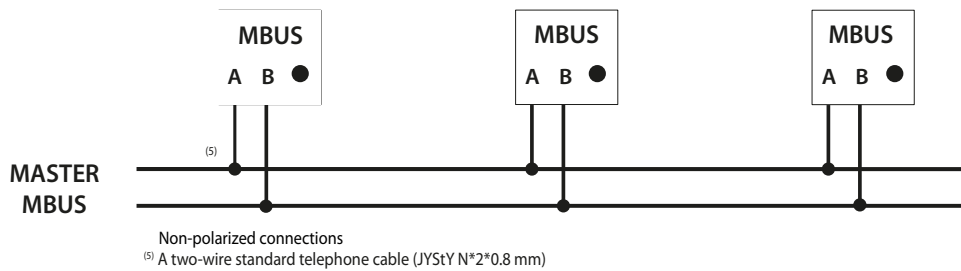

Communication tables

- The MODBUS and MBUS communication protocols are available on the <http://www.imeitaly.com> site.