



# IDS 351

## Electronic Pressure Switch with IO-Link Interface

Ceramic Sensor

accuracy according to IEC 60770:  
0.5 % FSO

### Nominal pressure

from 0 ... 0.4 bar up to 0 ... 600 bar gauge  
from 0 ... 0.6 bar up to 0 ... 600 bar absolute

### Digital output signal

IO-Link according to specification V 1.1  
smart sensor profile  
data transfer 38.4 kbit/sec

### Switchable output signal

PNP / NPN / 4 ... 20 mA / 0 ... 10 V

### Special characteristics

- ▶ indication of measured values on a 4-digit LED display
- ▶ rotatable and configurable display module
- ▶ parameter settings via IO-Link or menu (VDMA-conform)
- ▶ additional information via IO-Link accessible

### Optional versions

- ▶ different mechanical connections
- ▶ pressure port in PVDF
- ▶ customer specific versions



The IDS 351 has been designed for applications in machine tools or pneumatic and hydraulic systems. In combination with the optionally available PVDF pressure port also the usage in aggressive media is possible, whereby material resistance has to be checked in advance.

It offers an IO-Link interface as standard, which provides process data, diagnostics reports and status messages as well as other features, which are helpful for service / maintenance and condition analysis of a machine or plant.

The parameters are set either also via control level or via VDMA-compliant menu system, which can be carried out in situ by using two buttons.

The multiple, infinitely variable adjustability of the display as well as the individually parameterizable output signal (switching or analogue signal (mA / V)) support the user in realizing the measurement task.

### Preferred areas of use are

-  Plant and machine engineering
-  Environmental engineering  
(water – sewage – recycling)



<b>Input pressure range</b>																			
Nominal pressure gauge	[bar]	-1...0	0.4	0.6	1	1.6	2.5	4	6	10	16	25	40	60	100	160	250	400	600
Nominal pressure absolute	[bar]	-	-	0.6	1	1.6	2.5	4	6	10	16	25	40	60	100	160	250	400	600
Overpressure	[bar]	4	1	2	2	4	4	10	10	20	40	40	100	100	200	400	400	600	800
Burst pressure $\geq$	[bar]	7	2	4	4	5	5	12	12	25	50	50	120	120	250	500	500	650	880
Vacuum resistance	[bar]	$p_N \geq 1$ bar: unlimited vacuum resistance $p_N < 1$ bar: on request																	
<b>Supply</b>		Voltage supply $V_S = 18 \dots 30 V_{DC}$																	
<b>Output signals</b>		Output signal 1 IO-Link / SIO (PNP / NPN) switchable Output signal 2 4 ... 20 mA / 3-wire or 0 ... 10 V / 3-wire or PNP / NPN switchable																	
<b>Signal characteristics switching signal</b>		Accuracy of switching points <sup>1</sup> $\leq \pm 0.5 \% FSO$ Repeatability $\leq \pm 0.1 \% FSO$ Max switching current 150 mA Switching frequency max. 170 Hz Delay time 0.0 ... 50.0 sec Response time < 12 msec																	
<b>Signal characteristics analogue signal</b>		Accuracy <sup>1</sup> $\leq \pm 1 \% FSO$ Long term stability $\leq \pm 0.3 \% FSO / \text{year}$ at reference conditions Load (4 ... 20 mA / 3-wire) $R_{max} = 330 \Omega$ Load (0 ... 10 V / 3-wire) $R_{min} = 10 k\Omega$ Influence effects supply: 0.05% FSO load: $\leq 0.1 \% FSO$ Adjustability offset: $\pm 5 \%$ span: -10 %																	
<sup>1</sup> accuracy according to IEC 60770 – limit point adjustment (non-linearity, hysteresis, repeatability)																			
<b>Thermal effects (offset and span)</b>		Thermal error $\leq \pm 0.3 \% FSO / 10 K$ in compensated range -25 ... 85 °C																	
<b>Permissible temperatures</b>		Permissible temperatures <sup>2</sup> medium: -40 ... 125 °C electronics / environment: -40 ... 85 °C storage: -40 ... 100 °C																	
<sup>2</sup> for pressure port of PVDF the minimum permissible temperature is -30 °C																			
<b>Electrical protection</b>		Short-circuit protection permanent Reverse polarity protection no damage, but also no function Electromagnetic compatibility emission and immunity according to EN 61326																	
<b>IO-Link</b>		Interface IO-Link 1.1; slave Data transfer 38.4 kbit/sec (COM 2) Mode SIO / IO-Link Standard IEC 61131-2 IEC 61131-9																	
<b>Mechanical stability</b>		Vibration 10 g / 25 Hz ... 2 kHz according to DIN EN 60068-2-6 Shock 500 g / 1 msec according to DIN EN 60068-2-27																	
<b>Materials</b>		Display housing PA 6.6 Housing stainless steel 1.4404 (316L) Pressure port standard: stainless steel 1.4404 (316L) option for G1/2" open port (with $p_N \leq 60$ bar): PVDF Seal standard: FKM option: EPDM (for $p_N \leq 160$ bar) others on request Diaphragm ceramics Al <sub>2</sub> O <sub>3</sub> 96 % Media wetted parts pressure port, seal, diaphragm																	

# IDS 351

Electronic Pressure Switch with IO-Link Interface

Technical Data

Miscellaneous	
Display	4-digit, 7-segment-LED display on black base body, white, blue foil, digit height 7 mm, range of indication -1999 ... +9999, visible range 22.5 x 10.5 mm 4 LEDs for unit switching (bar, mbar, PSI, MPa) LED status display for IO-Link and contacts
Operation	2 buttons
Featured	functions according to VDMA 24574-1
Turn-on time	110 msec
Weight	approx. 230 g
Operational life	100 million load cycles
Current consumption	< 50 mA (without contacts)
Ingress protection	IP 67
Installation position	any
CE-conformity	EMC Directive: 2014/30/EU Pressure Equipment Directive: 2014/68/EU (module A) <sup>3</sup>

<sup>3</sup> This directive is only valid for devices with maximum permissible overpressure > 200 bar.

### Wiring diagram

3-wire-system (IO-Link / SIO with contact, analogue output)

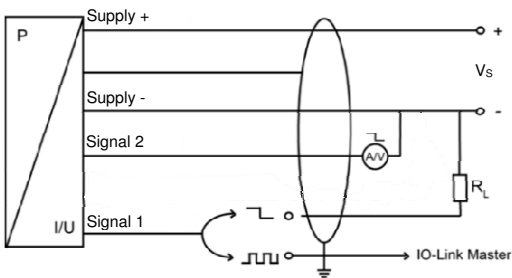

### Electrical connection

Pin configuration	Description	M12x1 (4-pin), metal	
Supply +	supply	1	
Supply -	supply	3	
Output signal 1	IO-Link / SIO (PNP / NPN)	4	
Output signal 2	4 ... 20 mA - 3-wire / 0 ... 10 V - 3-wire (PNP / NPN)	2	
Shield	shielding	plug housing	

### Dimensions (mm / in)

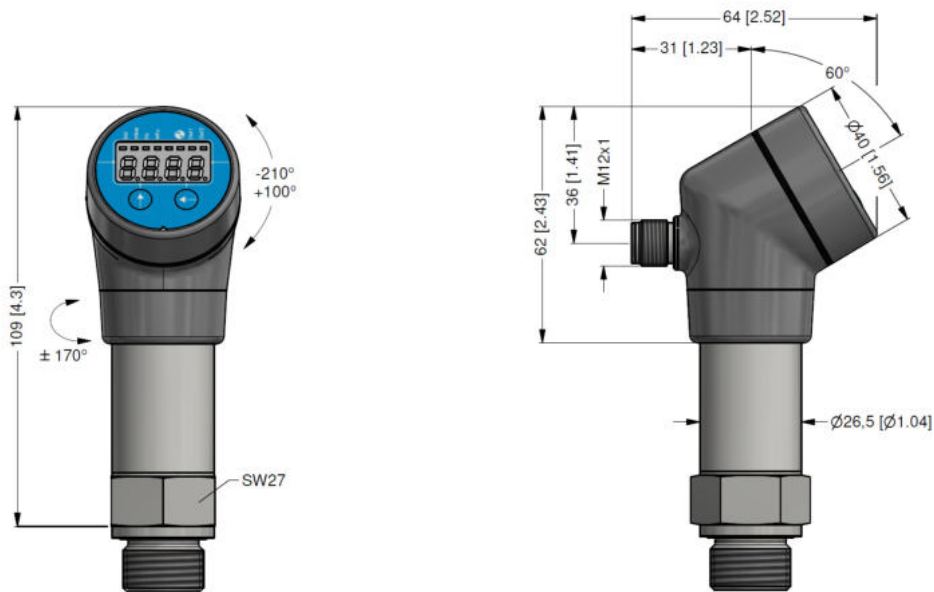

**Mechanical connections (dimensions mm / in)**

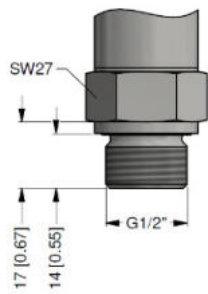

G1/2" DIN 3852

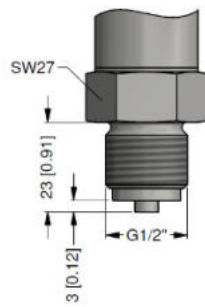

G1/2" EN 837

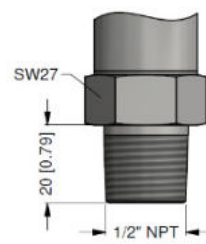

1/2" NPT

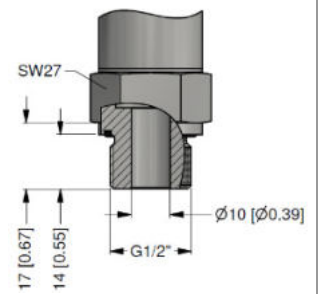

G1/2" DIN 3852 open port <sup>4</sup>

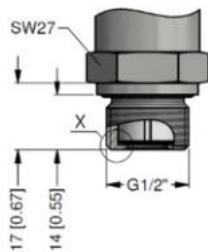

G1/2" DIN 3852 with semi-flush diaphragm  
p<sub>N</sub> ≤ 40 bar

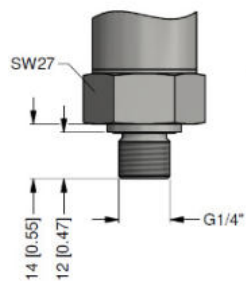
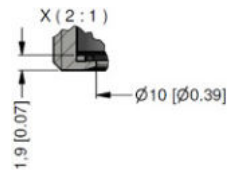

G1/4" DIN 3852

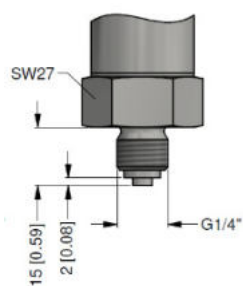

G1/4" EN 837

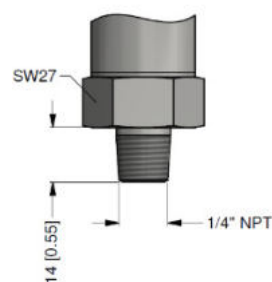

1/4" NPT

⇒ metric threads and other versions on request

<sup>4</sup> pressure port in PVDF only possible for p<sub>N</sub> ≤ 60 bar

## Ordering code IDS 351

IDS 351



<b>Pressure</b>											
	gauge	7	E	2							
	absolute	7	E	3							
<b>Input</b>											
	only gauge	0.40	4	0	0	0					
		0.60	6	0	0	0					
		1.0	1	0	0	1					
		1.6	1	6	0	1					
		2.5	2	5	0	1					
		4.0	4	0	0	1					
		6.0	6	0	0	1					
		10	1	0	0	2					
		16	1	6	0	2					
		25	2	5	0	2					
		40	4	0	0	2					
		60	6	0	0	2					
		100	1	0	0	3					
		160	1	6	0	3					
		250	2	5	0	3					
		400	4	0	0	3					
		600	6	0	0	3					
	-1 ... 0		X	1	0	2					
	customer		9	9	9	9					consult
<b>Output</b>											
	IO-Link + PNP/NPN + analogue output <sup>1</sup>						I	X			
<b>Accuracy</b>											
	0.5 % FSO						5				
	customer						9				consult
<b>Electrical connection</b>											
	male plug M12x1 (4-pin) / metal						M	1	B		
	customer						9	9	9		consult
<b>Mechanical connection</b>											
	G1/2" DIN 3852						1	0	0		
	G1/2" EN 837						2	0	0		
	G1/4" DIN 3852						3	0	0		
	G1/4" EN 837						4	0	0		
p <sub>N</sub> ≤ 40 bar:	G1/2" DIN 3852						F	0	0		
	with semi-flush sensor										
	G1/2" DIN 3852 open port						H	0	0		
	1/2" NPT						N	0	0		
	1/4" NPT						N	4	0		
	customer						9	9	9		consult
<b>Seal</b>											
	FKM								1		
p <sub>N</sub> ≤ 160 bar:	EPDM								3		
	customer								9		consult
<b>Pressure port</b>											
	stainless steel 1.4404 (316L)								1		
	PVDF <sup>2</sup>								B		
	customer								9		consult
<b>Diaphragm</b>											
	ceramics Al <sub>2</sub> O <sub>3</sub> 96 %								2		
	customer								9		consult
<b>Special version</b>											
	standard								0	0	0
	customer								9	9	9
											consult

<sup>1</sup> contact PNP/NPN switchable; analogue output 0 ... 10 V / 4 ... 20 mA switchable

<sup>2</sup> PVDF only with G1/2" DIN 3852 open pressure port (up to 60 bar); min. permissible temperature -30°C