

OPERATING INSTRUCTIONS PRESSURE TRANSMITTER

SERIES

23, 25
22DT, 22M, 22S
21C, 22C, 23C, 25C
23SX, 23SXc, 33X, PD-33X
35X, 35XHT, 35XHTT, 35XHTC, PD-39X, PRD-33X, 41X
21Y, 21PY, 23SY, 25Y, 25SY
M5HB, M8coolHB, 21PHB, 23SHB, 25SHB
21Zio, 23SZio
and various other customised series



CONTACT

KELLER AG
für Druckmesstechnik
St. Gallerstrasse 119
CH-8404 Winterthur
Tel. +41 52 235 25 25
info@keller-druck.com

Keller Gesellschaft
für Druckmesstechnik mbH
Schwarzwaldstrasse 17
DE-79798 Jestetten
Tel. +49 7745 9214 0
eurocenter@keller-druck.com

You can find details of other international KELLER subsidiaries and agents at <https://keller-druck.com/en/company/subsidiaries>

1. GENERAL INFORMATION AND SAFETY INSTRUCTIONS

These operating instructions contain important information about using the device correctly. The quick installation guide enclosed will be sufficient for experienced specialist personnel. Please read these operating instructions carefully for a detailed explanation of how to install the device and put it into operation. Follow the safety information in these operating instructions. You must also comply with national legislation, standards and regulations. These operating instructions form an integral part of the device and must always be accessible to the relevant staff.

Disclaimer

KELLER accepts no liability in case of improper use, damage or modification to the device or failure to observe this manual.

SUBJECT TO TECHNICAL ALTERATIONS!

1.1. SYMBOLS USED

SYMBOL	WARNING	NATURE AND SOURCE OF THE DANGER
	DANGER	Danger of death or injury to staff.
	WARNING	Potentially hazardous situation that could result in serious injuries or even death.
	NOTE	Tips and information for users.

1.2. INTENDED USE

- The pressure transmitter is used to convert a pressure into a standardised electrical signal.
- The pressure transmitters in the various series referred to have been developed for relative, absolute or differential pressure applications depending on their type.
- Make sure that the device is suitable for your corresponding application. Please get in touch with your direct sales contact if you are unsure of anything.
- Please refer to the relevant data sheet and agreed specifications for information about the pressure transmitter's features.
- The technical specifications listed in the data sheet are only binding insofar as no other agreements have been made.
- The gases or liquids used as measuring media must be compatible with the materials specified in the data sheet that come into contact with the media.

	DANGER	In the event of incorrect use!
--	--------	--------------------------------

1.3. STAFF QUALIFICATIONS

The product must only be assembled, installed, put into operation, operated, maintained, taken out of operation and disposed of by technically trained staff.

2. PRODUCT IDENTIFICATION



Example of label

The label and the specifications on the product serve to identify it. Both the laser-engraved or adhesive labels contain at least the following information:

- Product number
- Type designation
- Pressure range
- Output signal
- Supply voltage
- Electrical connections
- Production date

Products with a serial number display this on the metal housing.

3. MOUNTING

	DANGER	Danger of death by electrocution, pressure discharge or leaking media! The device must only be installed on systems when they are not pressurised or connected to a power supply.
	WARNING	Danger of death in the event of incorrect installation! The device must only be installed by specialist personnel who have read and understood these operating instructions. Follow the national standards and safety regulations during the assembly and installation of the device.
	DANGER	Danger of death in the event of incorrect use! For oxygen applications, only the pressure transmitters intended for this purpose and marked accordingly may be used.

3.1. INSTALLATION AND SAFETY INFORMATION

- Only operate the device within its technical performance limits. You can find these on the label, in the data sheet or in the specifications. The device must not be operated for long periods in its overload range as this can damage it.
- The measuring medium must not be permitted to ice up.
- Make sure that the material used for the selected pressure transmitter, including the associated seals, is suitable for the medium to be measured.
- Avoid electrochemical voltage potentials.
- Do NOT use the device to perform safety functions.
- Do not remove the packaging and protective cap until immediately before installation to avoid damaging the diaphragm and thread.
- In the case of pressure transmitters with a pressure range > 60 bar, there may be some oil left in the pressure connection from the calibration process.
- The output signal may be dependent on the installation position. Always tighten the transmitter to the manufacturers' instructions
- When installing the device on hydraulic systems, ensure that the system is adequately ventilated.
- Avoid damaging the cable sheath.
- Feed the cable output on pressure transmitters with cable into a dry terminal box.
- Avoid excessive tensile loads on the cable connections.

When installing the device outdoors or in another damp environment, note the following points:

- Make sure that no moisture can penetrate inside the device.
- The protection classes for plugs given in the data sheet only apply in combination with a suitable, correctly installed mating plug / female connector.
- Make sure that liquid does not accumulate on any seal surfaces near the connector pins.
- Install the device where it is protected from direct sunlight. Otherwise, the maximum ambient temperature permitted risks being exceeded.

3.2. OXYGEN APPLICATIONS

Note the following points:

- The pressure transmitter must be suitable for use with oxygen.
- Make sure the pressure and temperature thresholds permitted are not exceeded.
- Do not unpack the device until immediately before installation.
- Avoid skin contact with the device to prevent fingerprints and grease residues forming.
- We recommend wearing suitable safety gloves.

3.3. MECHANICAL INSTALLATION

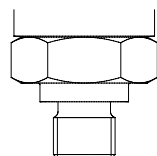

Example of a pressure connection

- Before installation, make sure that the seal surfaces on the device and the measuring point are clean and undamaged.
- Make sure that the seal is intact and sitting correctly in its groove. Check that the seal specifications correspond with the environment in which it will be used.
- Make sure that you do not damage the diaphragm. Flush connections must be handled with special care. Even small deformations can lead to an incorrect measurement result.
- Use suitable tools for installing the device.
- Tighten the pressure transmitter with the appropriate torque.

Follow the instructions below to ensure optimum installation:

- Make sure that the seal surface seals correctly.
- Screw the device into the corresponding thread **by hand**.
- Using a suitable torque wrench on the spanner flats, tighten the device into place.

- Install the device in such a way that it cannot be exposed to any prohibited mechanical tension. This could have a negative effect on the zero point and/or the characteristic lines.

3.4. ELECTRICAL INSTALLATION

- Connect the device according to the electrical connections on the label or the specification.
- Preferably use a shielded multi-wire cable.
- The device should be grounded via the pressure connection. If this is not possible, ensure it is adequately grounded via the plug or cable shield.
- For pressure transmitters with plugs, use only the mating plug supplied.
- Suitable mating plugs are either included with the device or available as accessories.
- In the case of devices with a cable, prevent the cable from kinking.
- Make sure that reference pressure transmitters (PR versions) have adequate, dry ventilation.

CONNECTION DIAGRAMS

2-wire / 4...20 mA

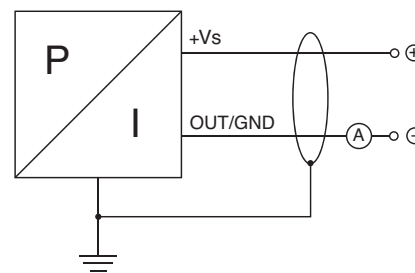

3-wire / 0...10 V / 0,5...4,5 V

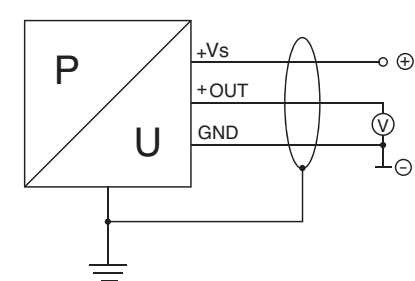

IO-Link

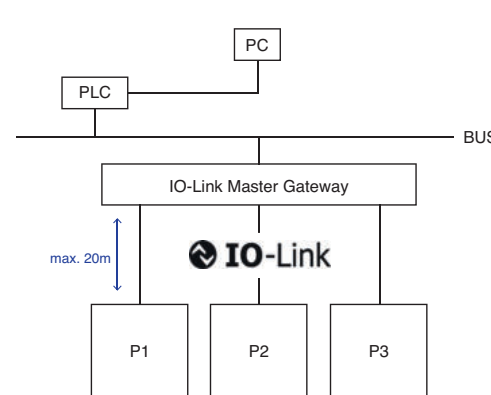

RS485

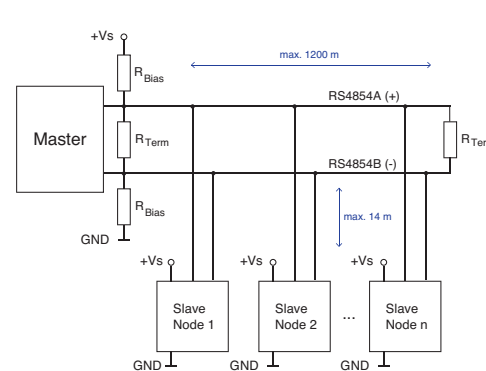

Please see the relevant communication protocol for additional connection diagrams.

COMMUNICATION PROTOCOLS

- You can find links to these via the relevant product on the KELLER website at www.keller-druck.com.

4. COMMISSIONING

	WARNING	Before operating the device for the first time, check whether the device has been installed properly.
	WARNING	The device may only be operated by qualified personnel who have read and understood the operating instructions.
	WARNING	The device may only be operated within the specifications. See the technical data sheet or the agreed specifications.

5. TROUBLESHOOTING

Common installation errors:

DIFFERENT ZERO POINT SIGNAL
Possible cause:
<ul style="list-style-type: none"> Diaphragm damaged Ambient temperature too high / low
Action:
<ul style="list-style-type: none"> Contact the manufacturer and, if necessary, replace the device Keep to the permitted temperatures given in the data sheet
SIGNAL SPAN DECLINES / IS TOO LOW
Possible cause:
<ul style="list-style-type: none"> Mechanical overload Abrasive / aggressive medium; corrosion on the diaphragm / pressure connection
Action:
<ul style="list-style-type: none"> Contact the manufacturer
CONSISTENT OUTPUT SIGNAL WHEN PRESSURE CHANGES
Possible cause:
<ul style="list-style-type: none"> Mechanical overload caused by overpressure Electrical fault
Action:
<ul style="list-style-type: none"> Replace the device; if the fault occurs again, contact the manufacturer
NO OUTPUT SIGNAL
Possible cause:
<ul style="list-style-type: none"> No supply voltage Transmitters polarities reversed Broken cable
Action:
<ul style="list-style-type: none"> Check the supply voltage Check that the connection corresponds with the pin assignment Check the cable continuity
SIGNAL SPAN FLUCTUATING
Possible cause:
<ul style="list-style-type: none"> Source of EMC interference nearby (e.g. pump, frequency converter, etc.)
Action:
<ul style="list-style-type: none"> Remove the source of interference Shield the source of interference properly

6. SERVICING AND REPAIRS

6.1. MAINTENANCE

KELLER products require no maintenance and, if used in accordance with the specifications, are fault free.

6.2. RECALIBRATION

Depending on the conditions where the device is used, its zero point or amplification may change over time, causing an incorrect output signal.

We recommend that highly accurate devices with an accuracy of < 0,1 %FS are periodically recalibrated or have their zero point adjusted.

6.3. RETURNS

Before returning a device for recalibration or repair, it must be thoroughly cleaned and securely packaged. For faulty devices, use the KELLER returns form and describe the fault in as much detail as possible.

If your device has come into contact with harmful substances, you must state this on the returns form.

If you return a device without mentioning contact with harmful substances and our repair department suspects that this is the case, the device will not be repaired until the facts have been established.

7. DISPOSAL

To dispose of the device, either return it to the supplier or dispose of it in a professional manner in accordance with Directive 2012/19/EU. Never allow it to enter household waste.

8. WARRANTY TERMS

The warranty is limited to 12 months from the date of delivery. KELLER guarantees that the products are free of manufacturing and material defects and that they comply with the specifications confirmed in writing.

9. EU DECLARATION OF CONFORMITY

The device supplied complies with the legal requirements. The relevant directives and harmonised standards are listed in the EU Declaration of Conformity applicable to the product. You can find the EU Declarations of Conformity by the relevant product at www.keller-druck.com.

Subject to technical alterations.
Version 02/2022.