

User manual for IPM5/IPW5-devices

Digital processor-controlled indication instrument for strain gauge measurement:
suitable for 4- or 6-wire measuring bridges (1.1mV/V; 2mV/V; 3.3mV/V; 6mV/V)



Panel meter with performance features as follows:

- adjustable input amplification for 1 mV/V, 2 mV/V or 3.3mV/V sensors
- 10 V integrated bridge supply for standard 350 ohm measuring bridges
- permanent wire-breach monitoring
- bipolar input range for compression and tensile forces
- integrated factory calibration for pre-calibrated weighing cells
- auto-sensor recognition for 1 mV/V, 2 mV/V and 3.3 mV/V
- measuring rate up to 50 measurements (measuring time adjustable from 0.02 to 10.000 sec)
- 24 bit transducer resolution, of which up to 19 bits (500,000 / 0.0002 % of measuring range), are noise-free!
- high long-term and temperature stability
- 5-digit digital display with range from -9999 to 99999 digits
- free scaling and setting of decimal point
- alignment of a sensor with up to 30 additional calibration points
- tare function for manual and automatic control
- fully automatic or semi-automatic calibration functions
- min/max-value recording, can be called up or shown permanently in the display
- integrated conversion function with adjustable factor
- complex parameter and access security via several user levels with event counter

Identifizierung

STANDARD TYPES	ORDER NUMBER
Supply 100-240 VAC 50/60 Hz, DC $\pm 10\%$	PM5.020X.1S70D
Supply 10-40 VDC galvanic isolated, 18-30 VAC 50/60 Hz	PM5.020X.1W70D

Options – breakdown order code:

	P	M	5.	0	2	0	X.	1	S	7	0	D		
Standard type													Internal index	
													D version D	
4-wire-sensor		M											Switching points	
6-wire-sensor		W												0 no switching points
														2 2 relay outputs
Number of digits													4 4 relay outputs	
5-digits														
Interface													Mechanical options	
none														7 IP65, foil keypad, plug-in terminal
RS232 (galvanic isolated)														
RS485 (galvanic isolated)														
Sensor supply													Voltage supply	
Bridge supply 10 VDC / 350 Ohm														S 100-240 VAC
													W 10-40 VDC	
Outputs													Housing size	
none														1 96x48 mm
0-10 V, 0-20 mA, 4-20 mA														
													Measuring input	
														X 1.1mV/V, 2mV/V, 3.3mV/V selectable

State physical unit on demand, e.g. kg.

Contents

1.	Brief description	2
2.	Technical data	3
3.	Safety advices	5
4.	Assembly	6
5.	Electrical connection	7
	5.1. Connection examples	9
6.	Operation and function description	10
	6.1 Operation	10
	6.2 Alarms / Relays	11
	6.3 Analog output	13
	6.4 Digital input / Tara	13
	6.4.1 Event counter	13
	6.4.2 Taring or calibration	13
	6.4.3 Adjustment with 80%-calibration (IPM5)	14
	6.4.4 Sensitivity recognition	14
	6.4.5 Automatical calibration	15
	6.4.6 Taring	15
	6.4.7 Hold-function	15
	6.5 Interfaces RS232 / RS485	16
7.	Programming	18
	7.1 Programming sequence	19
	7.1.1 Change from programming mode into operation mode	20
	7.2. Linearisation	21
8.	Programm number description	22
	8.1 Programm number table	28
9.	Reset to default values	33
10.	Error elimination	34

1. Brief description

With the **IPM5 and IPW5 panel meters**, sensor sizes can be directly recorded via strain gauges. For this purpose, the devices make an automatically controlled 10 V bridge supply available. The 5-digit display shows the measurement itself or the scaled value of the physical quantity. During programming, the display is used to feed back the set data and the user guide. A maximum of 4 relays are available to monitor the threshold values. Data from and to the device can be transmitted via the serial interface.

The **IPM5** has a 4-wire connection with an additional calibration contact for the 80% calibration with mass pressure sensors. The latter does not necessarily have to be used, which means that the unit is also suitable for any other desired strain gauge measurement.

The **IPW5** model is suitable for weighing because of its 6-wire measurement. The unit has a very high input resistance, which means that even higher-ohm bridges can be accurately measured.

2. Technical data

Housing		
Dimensions	96x48x120 mm (WxHxD)	
	96x48x139 mm (WxHxD) incl. plug-in terminal	
Panel cut-out	92.0 ^{+0.8} x 45.0 ^{+0.6} mm	
Wall thickness	up to 15 mm	
Fixing	screw elements	
Material	PC, black, UL94V-0	
Protection class	standard IP65 (front), IP00 (rear side)	
Weight	approx. 450 g	
Connection	plug-in terminal, cable cross-section up to 2.5 mm ²	
Display		
Digit height	14 mm	
Segment colour	red	
Display range	-9999 to 99999	
Switching points	1 LED per switching point	
Overflow	horizontal bars at the top	
Underflow	horizontal bars at the bottom	
Display time	0.1 to 10.0 seconds	
Strain gauge input	Measuring range	Metering precision at 1s measuring time
Measuring ranges adjustable	± 6 mV/V ± 3.3 mV/V ± 2m V/V ± 1m V/V	0.002% of measuring range under storing conditions 0.1% of meas. range in controlled electromagnetic environment 0.75% of measuring range in industrial areas
Input resistance	IPW5 > 10 MΩ IPM5 approx. 5	
Drift of temperature	kΩ 20 ppm/K	
Measuring principle	Sigma/Delta	
Measuring speed	0.01s...10.00s	
Resolution	24 bit, max. 19 bit RMS	

Output	
Relay	Switchover contact 250 VAC / 5A; 30 VDC / 5 A at ohm resistive burden
Switching cycle	0.5 * 10 ⁵ at maximum contact load 5 * 10 ⁶ mechanically Division according to DIN EN 50178/Characteristics according to DIN EN 60255
Analog output (galvanic isolated)	0/4-20 mA / burden <500 Ω, 0-10 VDC burden ≥10 kΩ, 16 bit
Error	0.1 % in a range of T _J = 20...40 °C, outside of 50 ppm/K
Bridge supply	approx. 10 VDC / 200-500 Ω, standard 350 Ω
Interface	
Protocol	manufacturer specific ASCII
RS232	9600 Baud, no parity, 8 data bit, 1 stop bit
Cable length	max. 3 m
RS485	9600 Baud, no parity, 8 data bit, 1 stop bit
Cable length	max. 1000 m
Power pack	
Voltage supply	100-240 VAC / 50/60 Hz, DC ± 10% (max. 15 VA) 10-40 VDC galv. isolated, 18-30 VAC / 50/60 Hz (max. 15 VA)
Memory	
Parameter memory	EEPROM
Data life	≥ 100 years at 25°C
Ambient conditions	
Working temperature	0...50°C
Storing temperature	-20...80°C
Weathering resistance	relative humidity ≤ 75% on years average without dew
EMV	
	DIN 61326
CE-sign	
	conformity according directive 2004/108/EG
Safety standard	
	according to low voltage directive 2006/95/EG; EN61010; EN60664-1

3. Safety advices

Please read the users guide before installation and keep it for future reference.

Proper Use

The **IPM5/IPW5** device is designed for the evaluation and display of sensor signals. With the setpoints it is possible to perform simple control tasks.



Danger! Careless use or improper operation can result in personal injury and/or damage the equipment.

Control of the device

The panel meters are checked before dispatch and sent out in perfect condition. Should there be any visible damage, we recommend close examination of the packaging. Please inform the supplier immediately of any damage.

Installation

The **IPM5/IPW5** device must be installed by a suitably **qualified specialist** (e.g. with a qualification in industrial electronics).

Notes on installation

- There must be no magnetic or electric fields in the vicinity of the device, e.g. due to transformers, mobile phones or electrostatic discharge.
- **The fuse rating of the supply voltage should not exceed a value of 0.5A N.B. fuse!**
- Do not install **inductive consumers** (relays, solenoid valves etc.) near the device and **suppress** any interference with the aid of RC spark extinguishing combinations or free-wheeling diodes.
- Keep input, output and supply lines separate from one another and do not lay them parallel with each other. Position “go” and “return lines” next to one another. Where possible use twisted pair. So, you receive best measuring results.
- Screen off and twist sensor lines. Do not lay current-carrying lines in the vicinity. Connect the **screening on one side** on a suitable potential equaliser (normally signal ground).
- The device is not suitable for installation in areas where there is a risk of explosion.
- Any electrical connection deviating from the connection diagram can endanger human life and/or can destroy the equipment.
- Do not install several devices immediately above one another or in an extremely thermal isolated housing. Due to the internal heat dissipation of the devices, the recommended ambient temperature can be exceeded.
- The terminal area of the devices is part of the service. Here electrostatic discharge needs to be avoided. Attention! High voltages can cause dangerous body currents.
- Galvanic isolated potentials within one complex need to be placed on a appropriate point (normally earth or machines ground). So, a lower disturbance sensibility against impacted energy can be reached and dangerous potentials, that can occur on long lines or due to faulty wiring, can be avoided.

4. Assembly

Please read the *Safety advices* on *page 5* before installation and keep this user manual for future reference.

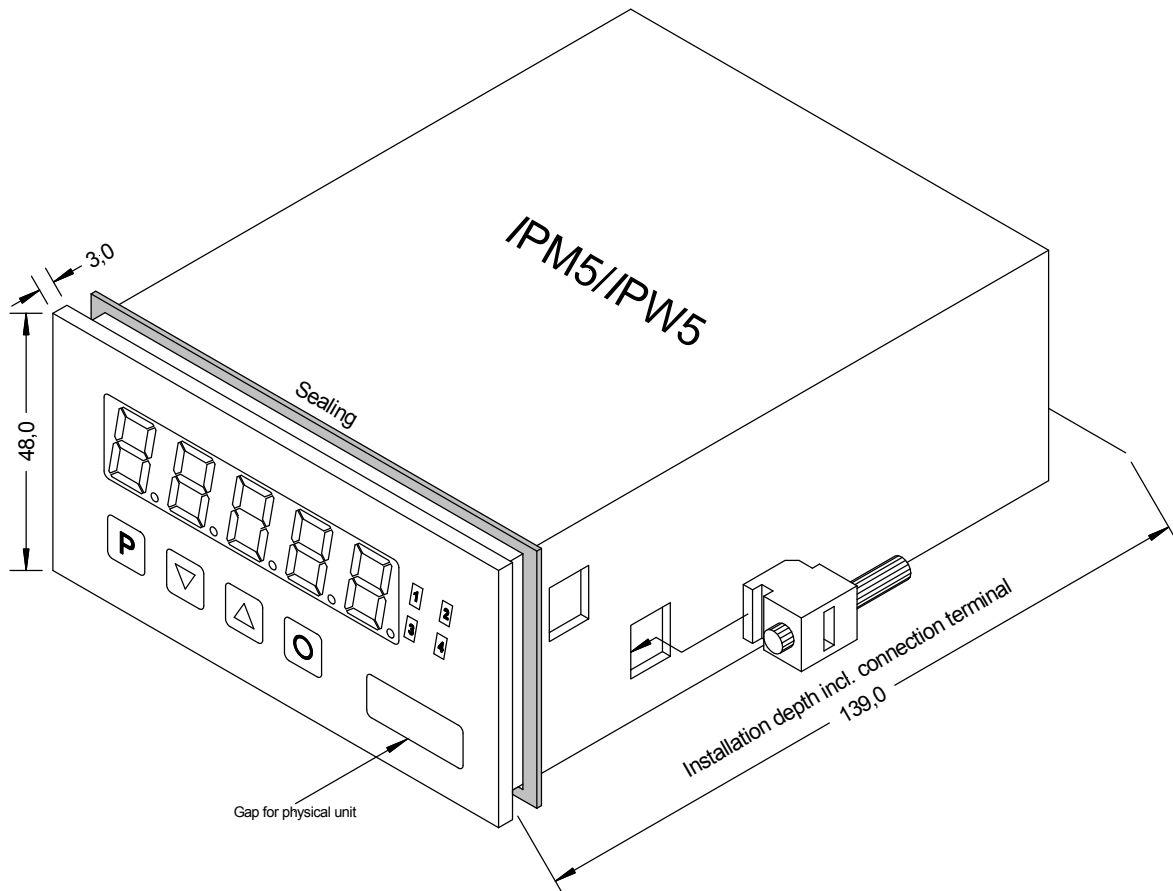

1. After removing the fixing elements, insert the device.
2. Check the seal to make sure it fits securely.
3. Click the fixing elements back into place and tighten the clamping screws by hand. Then use a screwdriver to tighten them another half a turn.

CAUTION! The torque should not exceed 0.1 Nm!

The dimension symbols can be exchanged before installation via a channel on the side!

5. Electrical connection

All the necessary signals for operation are connected to the rear terminals.

Upper connecting terminals

If none of the options **switching points** or **interface** were implemented, then the corresponding terminal strip is missing. The switching points are tapped on the 12-pole connector strip. Depending on the version, there are between zero, two and four changeover contacts (**N**ormally-**C**lose, **C**OMmon, **N**ormally-**O**pen).

Relay 1			Relay 2		
21	22	23	24	25	26
NO	NOC	Com	NO	NOC	Com

Relay 3			Relay 4		
27	28	29	30	31	32
NO	NOC	Com	NO	NOC	Com

A serial interface can be connected via the 3-pole connector strip.

RS232		
41	42	43
GND (RS)	TxD	RxD

or

RS485		
41	42	43
GND (RS)	Data B (+)	Data A (-)

The lines of the RS232-interface need to be connected 1:1, TxD to TxD and RxD to RxD.

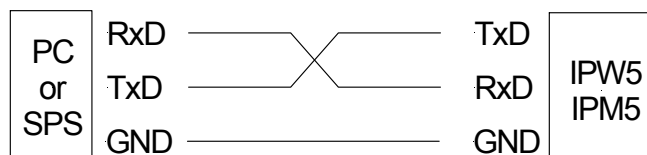

Connection figure PC or SPS ↔ IPW5/IPM5

Interface RS485 is connected via a shielded data line with twisted wires (**Twisted-Pair**).

At each end of the bus, a **termination** of the bus lines must be connected. This is necessary to guarantee reliable data transmission on the bus. For this, a resistance of 120 Ohm is inserted between the lines Data B (+) and Data A (-).

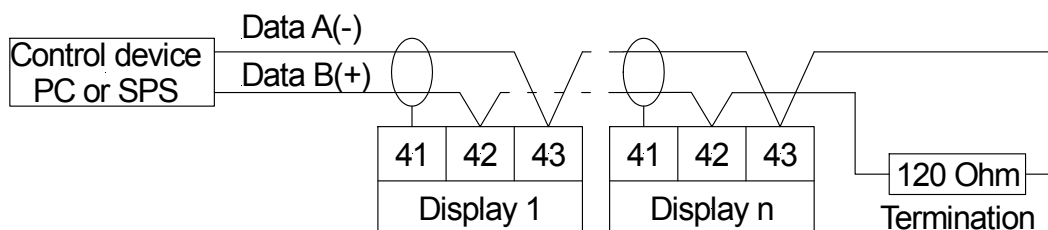

Caution!

The potential reference can lead to a compensating current (interface ↔ measuring input) with a galvanic not isolated interface and can thus affect the measuring signals.

Lower connecting terminals

Input signal, analogue output, sensor supply and supply voltage are connected to the lower connecting terminal.

Terminal 1-7: Input signals

The sensor is connected to these terminals.

A 6-wire sensor can be connected to the input of the **IPW5**.

Sensor	1	2	3	4	5	6	7
Strain gauge sensor	Supply+	Sense+	Signal+	Signal-	Sense-	Supply-	Shield

If the sensor only has a 4-wire connection, terminals 1 and 2 or terminals 5 and 6 can be bridged directly to the display. However, as a rule, this generally leads to a loss of accuracy through the line impedance.

At the input of the **IPM5**, a 4-wire sensor can be connected with a calibration wire (CAL).

Sensor	1	2	3	4	5	6	7
Strain gauge sensor	Supply+	Supply+	Signal+	Signal-	Supply-	Supply-	CAL

Mass pressure sensors, which frequently have an additional wire for the artificial unbalance (80%) of the bridge, can be automatically calibrated via terminal 7.

Examples of the connections for various sensors can be found in section “**Connection examples**”.

Terminal 8-9: Analog output

These terminals supply the signal of the analog output. Via a DIP switch on the back side of the device, a voltage signal of 0-10 VDC or a current signal of 0/4-20 mA can be measured.

8	9
Analog output +	Analog output -

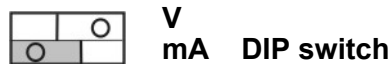

Terminal 10-12: Digital input

These terminals are used to control the digital input. With this, various functions (e.g. taring) can be triggered in the unit. With a potential-free external contact, terminals 10 and 12 are simply connected. With an active output, terminal 11 serves as reference point. The digital input is designed for an input signal of 24 VDC.

10	11	12
Contact supply +	Contact supply -	Digital input

Terminal 13-14: Auxiliary supply / Voltage supply

The supply voltage for the unit is connected to these terminals. The supply voltage is galvanic isolated from the measuring input.

13	14	Auxiliary supply / Voltage supply
L+	L-	10-40 VDC / 18-30 VAC
L	N	100-240 VAC / DC \pm 10%

5.1. Connection examples

This section gives a few examples of practical connections. Other connection options can be combined from the various examples.

Measurement of a **6-wire sensor** with a **IPW5** using the digital input via a potential free contact; auxiliary voltage 100-240 VAC

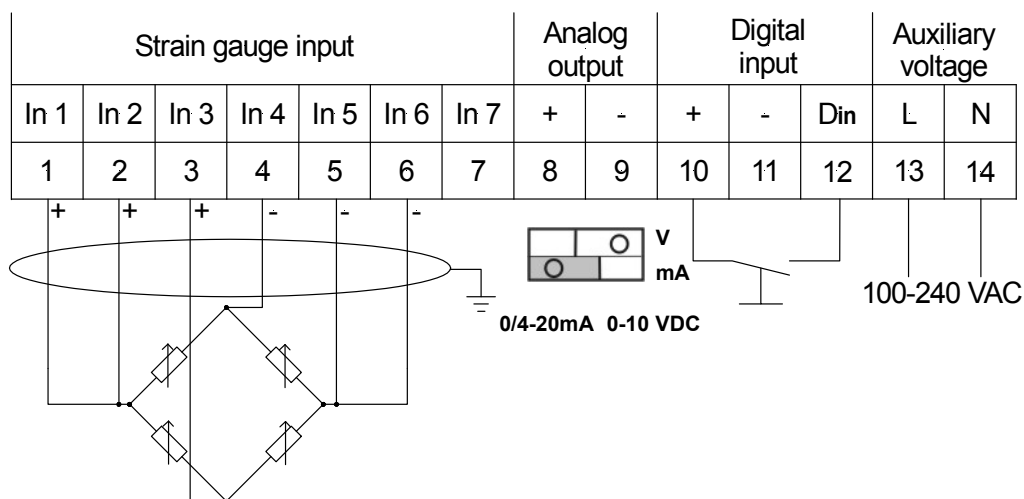

Measurement of a **4-wire sensor** with a **IPM5** with an actively switched digital input; auxiliary voltage 10-40 VDC:



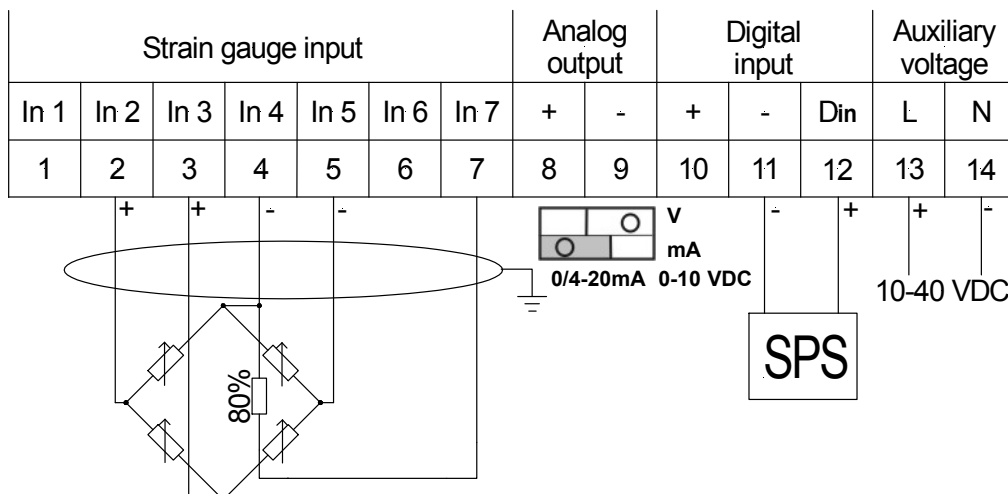



Important: The potential of the digital input is connected with the sensor potential.

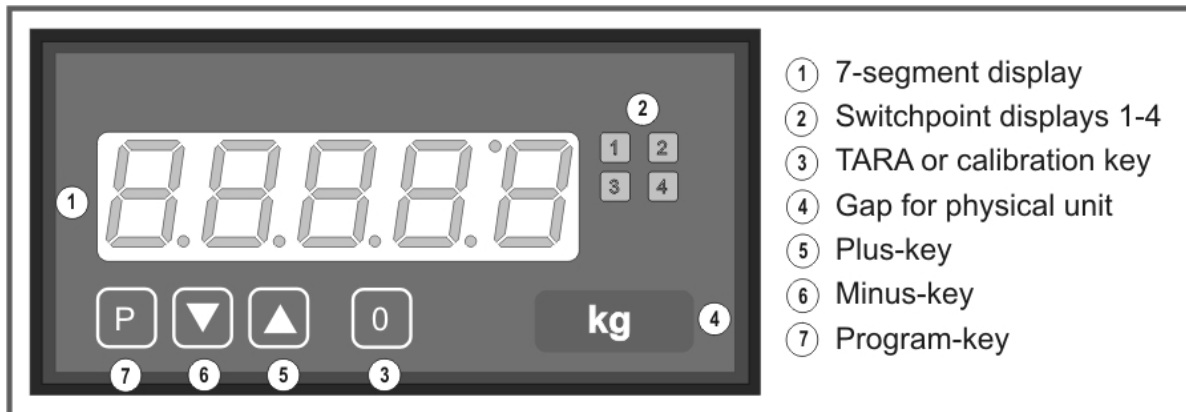

6. Operation and function description

6.1. Operation



Display (1)	
7-segment display	5-digit, red
Digit height	14 mm
Display range	-9999...99999
Positions after decimal point	none, one, two, three, four (adjustable)
Unit	°C, °F, Pt100, thermocouple
Switchpoint displays (2)	
Optical limit value report	4 LED, red
Keys (5), (6), (7), and (3)	
	Programming mode
	Increase range of value
	Reduce range of value
	Select next lower program number
	Select next higher program number
	Triggering of TARA or calibration
Gap for physical unit (4)	
Slide-in dimension strip	Dimension on demand e.g. kg

Switching on

Before switching on check all electrical connections to make sure they are correct. On completion of the installation, the device can be switched on by applying the supply voltage.

Starting sequence

During the switching-on process, a segment test is performed for approx. 1 second, whereby all LED on the front (including switchpoint LED) are triggered. After this, the type of software is indicated for approx. 1 second and then, also for 1 second, the software version. After the starting procedure, the unit changes to operation mode / display mode.

Min/max-memory

The measured minimum- and maximum-values are saved in a volatile memory in the unit and get lost when the unit is switched off.

You can call up the contents of the memory by pushing (less than 1 second) the [**▲**]- or [**▼**]-key. The relevant value is indicated for approx. 7 seconds. By briefly pressing the same key again, you will return immediately to the display mode.

[**▲**] ⇒ display of max-value

[**▼**] ⇒ display of min-value

Erase the value that is shown in the display by simultaneously operating the [**▲**]- and [**▼**]-keys. The erasure is acknowledged by horizontal bars. The content of the memory will be lost with switching off the device.

Overflow / Underflow	
Overflow	An overflow of the display is indicated by horizontal bars at the top of the 7-segment display.
Underflow	An underflow of the display is indicated by horizontal bars at the bottom of the 7-segment display.

6.2 Alarms / Relays

With the aid of the LED next to the 7-segment display, the switching state of the relays is displayed. An active relay is indicated by the relevant LED lighting up.

The relays have the following properties with regard to their switching characteristics:

Setpoint x	deactivated or activated
Threshold	threshold value for switchover
Hysteresis	width of the window between the switch thresholds
Operating principle	active above SP value / active below SP value
Switch-on-delay	time between reaching the threshold and the resultant switching on of the relay
Switch-off-delay	Time between reaching the threshold and the resultant switching off of the relay

Operating current

The setpoint is “off” below the threshold and “on” on reaching the threshold.

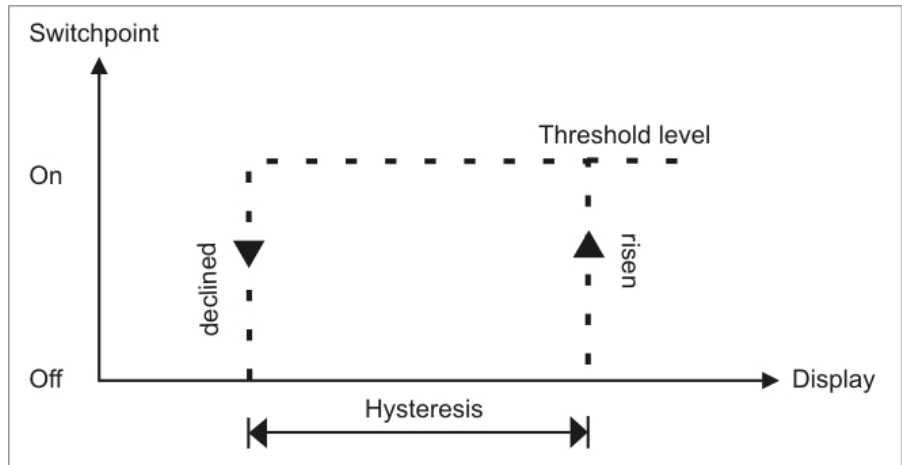

Quiescent current

The setpoint is “on” below the threshold and switched “off” on reaching the threshold.

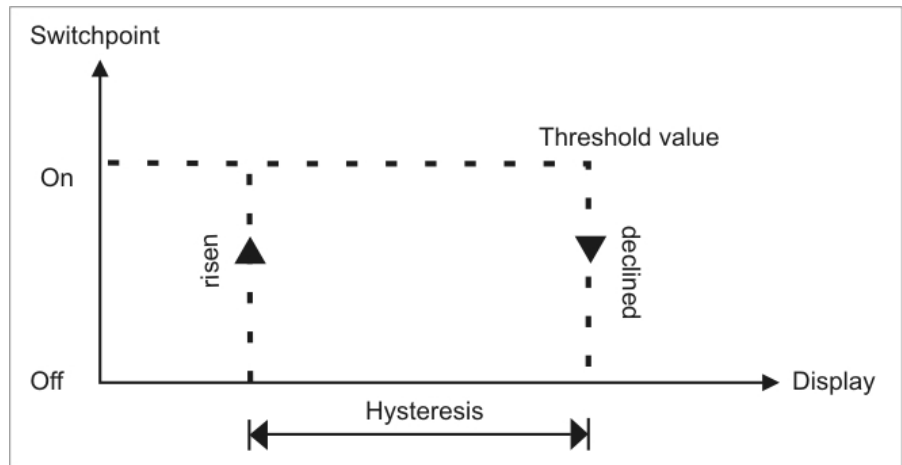

Switching-on delay

The relay S1-S4 is “on” 10 seconds after reaching the threshold; briefly exceeding the threshold does not lead to the relay being switched on. The switch-off delay functions in a similar manner, in other words it keeps the set point switched on until the parameterised time has elapsed.

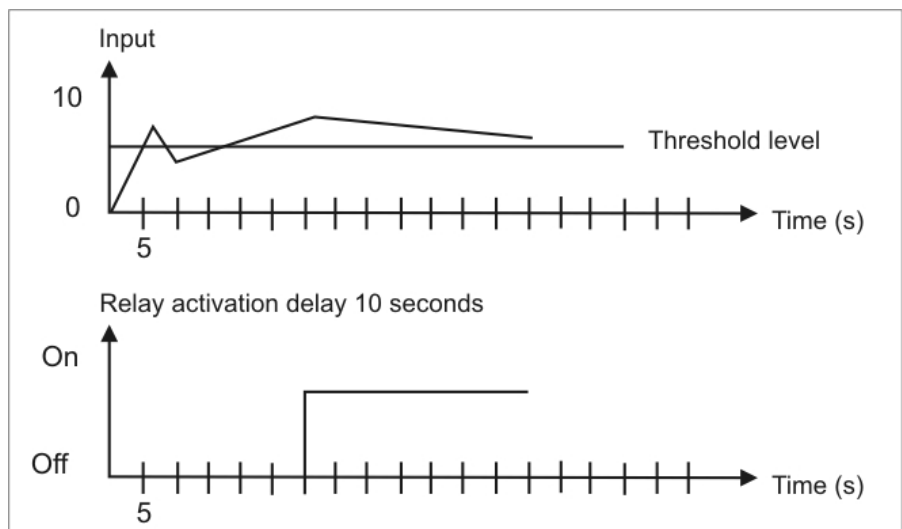

Optical response, display flashing

The switching on of one or more setpoints can also be set to trigger a flashing of the display to enhance the optical response.

Example:

Let us assume the threshold for flashing of the display is set at setpoint 2. If setpoint 1 is exceeded and setpoint 2 is not, the setpoint **LED 1** lights up permanently. If setpoint 2 exceeds the threshold, the 7-segment display will start to flash, setpoint 1 will light up permanently and setpoint LED 2 will flash.

The flashing enhances the optical response and the operator sees immediately that an important threshold has been exceeded with this unit.

6.3 Analog output

The analogue output is used to pass on a measured value. The selection of the signals happens under program number 23, so PN23=0 corresponds to the 0-10 V signal and PN=1 corresponds to the 0-20 mA signal. The analogue output is parameterised via the two program numbers **PN20 end value** (full scale) and **PN21 initial value** (offset). With the offset value, the value is set at which the analogue output shows its minimum value (e.g. 4 mA) and with the full scale, the value at which the output shows its maximum value (e.g. 20 mA).

It is possible in this way to rescale the input signal of a measuring transducer or even to convert it into another standard signal.

The analogue output can be deactivated or activated via the **PN22 control value**. Furthermore, the analogue output signal can either be allocated to the **current value** (with possible taring), the **min-value**, the **max-value**, the **Hold-value** or the **absolute value** (without possible taring).

The analogue output is updated in the cycle of the measuring time (PN14) and has, at maximum, a resolution of 12bit (4096 dots) and, at minimum, the resolution of the selected output range PN20 – PN21. In other words, if the difference between PN20 and PN21 is less than 4096, the resolution of the analogue output is reduced to PN20–PN21 dots!

6.4 Digital input

With the digital input, a wide variety of special functions can be triggered in the unit. These include various taring and calibration functions, the Hold-function and switching over of the display mode. The digital input can either be controlled actively with a 24 VDC signal or passively via a potential-free contact.

6.4.1 Event counter

Since a change made to the configuration opens the door to access calibratable areas, changes are recorded in an event counter. The event counter counts only when a change is made to the relevant configuration sections. This is displayed when the system is started up, as e.g. "C.0023", in order to allow the operating staff and quality management staff to check the configuration status.

6.4.2 Taring or calibration

Taring or calibration can be carried out via the 4th key on the front or the digital input on terminal 12.

The unit can, on being switched on, be set to various modes via program numbers. Furthermore, it is possible to differentiate between the evaluation of the key on the front and the digital input. The tare key on the front and the digital input are interrogated independently of one another. For taring, the 4th key, the digital input or both in parallel can be used.

6.4.3 IPM5 calibration of mass pressure sensors

Many standard sensors for mass pressure measurement have a special CAL wire. If this is connected to *DMS-minus (Strain gauge minus)*, an unloaded bridge becomes so unbalanced that the signal value corresponds to an 80% load (80% is a standard value that can, however, be changed for the display). In addition, the display has its own CAL terminal on which the signal wire can be laid. If a calibration is triggered, at first the unit automatically performs a zero balance and then a load balance. The latter is achieved by the display switching the CAL wire via a relay contact against supply, and then evaluating the signal value as an 80% load. This measurement is used for the linearisation.

6.4.4 Sensitivity recognition

The units support a sensitivity recognition, which can automatically distinguish between 1mV/V, 2mV/V and 3.3mV/V sensors. For this, a calibration point >0.00% must be selected. With the aid of the offset voltage and CAL voltage, the display can recognise whether it is a 1mV/V, 2mV/V or 3.3mV/V sensor and then adjusts the PN0. In the second run, the calibration is carried out in the relevant measuring zone.

The procedure is as follows:

Sensitivity recognition

- ⇒ Display of "SEnS" for the entire process.
- ⇒ Amplification of the measuring input is set to 1.
- ⇒ Offset voltage is measured.
- ⇒ CAL relay is switched.

In semi-automatic mode, the procedure is as follows:

- ⇒ Display of "Sen2" flashing ⇒ until **[P]** key or release is activated
- ⇒ CAL voltage is measured.
- ⇒ The calibration relay is switched off.
- ⇒ Display of "FInd1" with 1mV/V etc. ⇒ 1 second
If the sensor recognition has not identified an overflow and the sensor was able to allocate a 1mV/V- (=FInd1), 2mV/V- (=FInd2) or 3.3mV/V- (=FInd3) bridge
otherwise
- ⇒ display of an error message ⇒ 2 seconds

Error messages after sensitivity recognition (priority from 1 to 5)

- "SErr1" if no offset was recognised.
- "SErr2" when the end value for CAL is outside the permitted range.
- "SErr3" if the end value has not changed under CAL by min. 1% of measuring range
- "SErr4" when PN0 is set to 2, 3, 4 and the error is 10% higher than expected.
- "SErr5" when, in semi-automatic mode, 60 seconds has elapsed.

With an error message, no changeover of PN0 is made, otherwise, if PN0 is preset to 0 or 1, the value is changed to 2, 3 or 4. If PN0 is preset to 5 or 6, the most suitable amplification setting (PN0=7, 8 or 9) is set so that a resolution of around 120% of the end value can be ensured.

6.4.5 Automatic calibration

The **IPM5** unit generally performs an automatic calibration. Depending on the setting, this can be triggered via the 4th key or the digital input. During calibration, the sensor must be free of pressure or the balance is without any load. Since, in the case of the **IPW5**, manual intervention is generally required, the semi-automatic calibration takes effect here.

The calibration procedure is as follows:

Press **[CAL]-key**

- | | |
|--------------------------|-------------------------------------|
| ⇒ Display of "CAL1" | ⇒ 1 second |
| ⇒ Determine offset value | ⇒ display measurement for 2 seconds |

In semi-automatic calibration mode, this is followed by:

- | | |
|---|--|
| ⇒ Display of "CAL2" flashing | until [P] key or release is activated |
| ⇒ Display of " CAL2" | ⇒ 1 second |
| ⇒ Switch CAL line against strain gauge | ⇒ during display of CAL2 |
| ⇒ Determine load value n calibration point | ⇒ display measurement for 2 seconds |

If the calibration was successfully concluded,

- | | |
|---------------------------------------|-------------|
| ⇒ Display of "-----" | ⇒ 1 second |
| <i>Otherwise, if an error occurs,</i> | |
| ⇒ Display of error message | ⇒ 2 seconds |

The following error messages are possible (priority from 1 to 4):

- "CErr1" if neither offset nor end value are within the measuring range
- "CErr2" if the end value is not at least $\pm 1\%$ of measuring range greater than offset
- "CErr3" if the end value is outside the measuring range
- "CErr4" if the offset or end value at PN0 = 1, 2 or 3 is 10% $\lt \gt$ expected value
- "CErr5" termination of semi-automatic calibration after 60 seconds

6.4.6 Taring

In weighing technology, a taring process is generally carried out before proceeding with a measurement. This involves setting the display value for the current sensor value to zero. For these two cases, the standard taring procedure is as follows:

- | | |
|--|---------------------|
| ⇒ Display of "00000" | ⇒ 1 second |
| ⇒ Determine offset value | ⇒ in measuring time |
| ⇒ Display of "oFAIL" if measuring range overflow | ⇒ 2 seconds |

With rapid taring, only one error message, if available, is displayed. No message is sent if the taring process was successful as this is frequently not desired.

6.4.7 Hold-function

The Hold-function is always active in the background. If the digital input is deactivated, the Hold-value is permanently overwritten by the current measurement. Only when the digital input is activated the last measured measurement is recorded as long as the digital input remains activated. The function is purely static and can only be operated via the digital input.

6.5 Interface

All IPW5/IPM5 devices can be optionally programmed or configured via an interface. The devices do not have an interface as standard.

Pressing the ENTER or <CR> key is always denoted by ↵.

Operation mode PN34

The interface can be operated in various modes that can be parameterised via the PN34.

PN34=0

Standard operation, in which the unit only replies if called on to do so. This mode is used only for configuring.

PN34=1

Transmission mode, in which the measurements are cyclically transmitted via the serial interface within the set measuring time.

The transmission mode is interrupted on receipt of ">↵" and the unit changes to standard mode. To change back to transmission mode, the display must be restarted, either by entering the command **S** ↵ or by switching the device off and on.

With the transmission mode, the display value is transmitted via the interface in ASCII format. Minus signs and decimal points are also transmitted so that the output can be displayed directly on a terminal or processed by a SPS. Zeros at the front are suppressed during transmission. With an overflow or underflow, the display transmits horizontal bars (hyphens) " - - - - - ↵".

Examples: "0.00 ↵"; "-9.99 ↵"; "999.99 ↵"; "-123.45" ; " - - - - - ↵"

With the aid of this simple protocol structure, the display data can be transferred very easily to a PC etc. and are further processed there. In the simplest case, a terminal program from the operating system is sufficient to store the received data in a file.

RS232 / RS485

For configuration, a terminal program or a special configuration tool (e.g. "PM-Tool") can be used.

The communication is a straight point-to-point connection. The baud rate is set to 9600 baud, with 8 databits, without parity and one stopbit.

The structure of a command: *Program number / Command / Value / ↵.*

<i>Program number</i>	See program number table
<i>Command</i>	= describe a parameter with a decimal value B describe a parameter with a binary value
<i>Value</i>	A value from the range of values given in the program number table
↵	ENTER or <CR>, conclusion of any command

Below, for example, the value for the program number 61 is parameterised with a value of 5000.

"61=5000↵"

All values are written directly into the **EEPROM** of the unit and are valid after changing into operating mode. In contrast, the communication parameters of the interface only become effective after restarting the display.

To simplify the input, there is no need for "." (dots) and "," (commas).

In the basic setting, a message is not acknowledged, which enables the parallel programming of several displays. To check the overall configuration, a checksum can be called up on the LED display.

Successful programming is indicated by a "PROG" in the LED display.

If you want to call up the content of a program number (e.g. 61), you can do so with the command

"61☺"

The display sends the corresponding value back in ASCII format.

e.g. "5000☺"

Should a program number also contain subsidiary parameters – like the corresponding binary value in case of a calibration point – it can be called up via the extension "B".

e.g. "1B3433☺"

If the scaled value needs to be changed, the extension "=" is used.

e.g. "1=12000☺"

Any entry that cannot be interpreted is acknowledged with an "Err" in the display.

If a non-existent program number or an unknown command is sent, the display will acknowledge this with an "?" via the interface.

Under normal conditions, the display does not send an acknowledgement back. Only when the value is called up or the acknowledgement mode is activated by the ">" command, the display sends a response from then on. This mode is exited after restarting the unit or 15 seconds after receiving the last command.

Serial special commands

In addition to the program number control, special commands are also possible. In the following table we have dispensed with giving the ☺ □ at the end of the command.

Command	Acknowledgement	Function
S		Restart the display
Q		Change in display mode
A1	Display value	Call up display value via the interface
A2	min-value	Call up min-value via interface
A3	max-value	Call up max-value via interface
A4	Hold-value	Call up Hold-value via interface
A5	Absolute value	Call up absolute value (without tare) via the interface
RH	max reset	Reset the max-value
RL	min reset	Reset the min-value
TAR	Taring	Trigger tare via the interface
B	Binary value	Call up binary value via interface
KAL	Calibration	Perform autocalibration
KAL1	Calibration	Sensor calibration of the calibration point to PN1
KAL2	Calibration	Sensor calibration of the calibration point to PN2
U		Load default configuration
P		Call up test total
>>		Activate interface acknowledgement

7. Programming

Functional diagram of programming via key pad

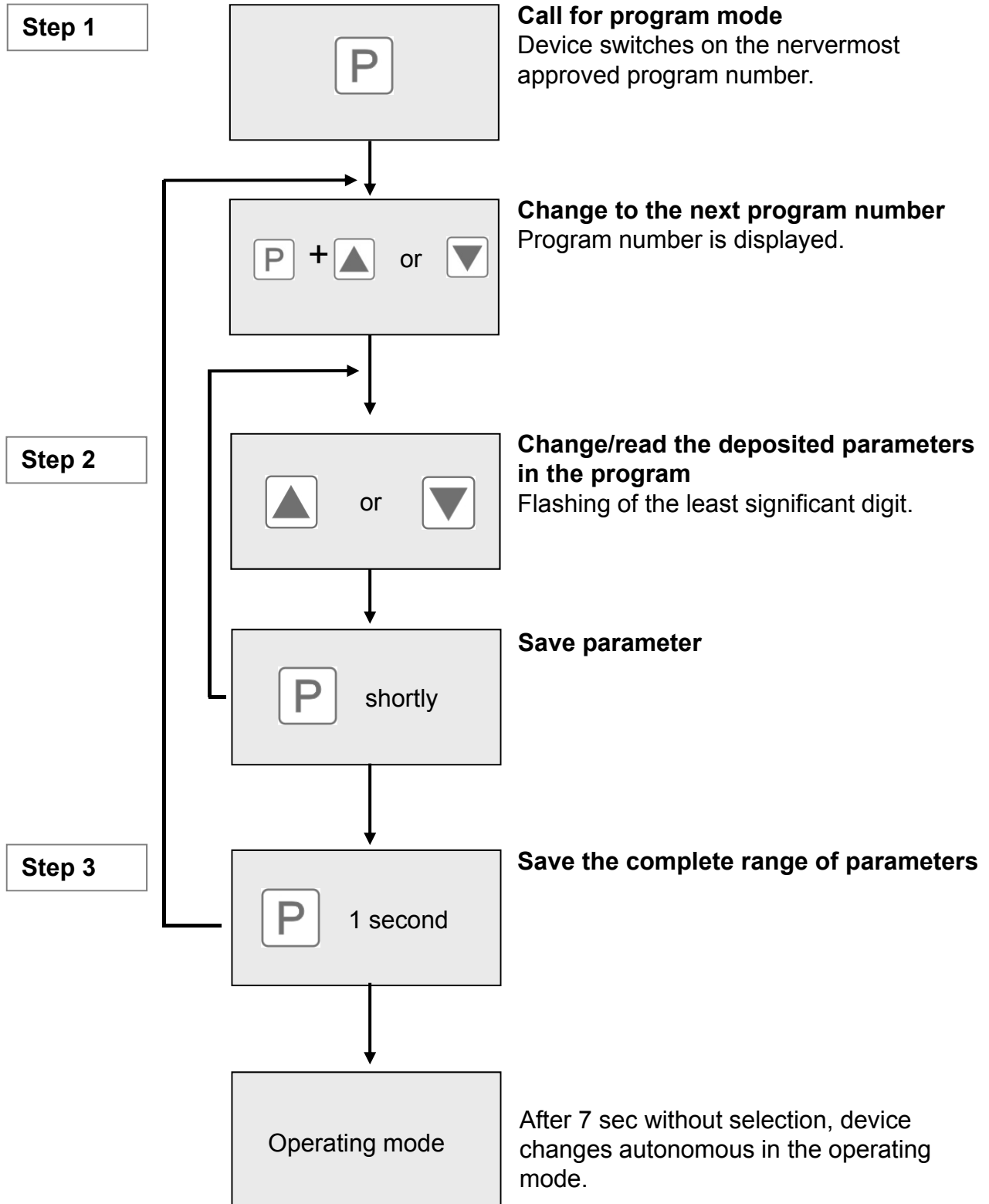

Description of the program numbers

In the display, the program numbers (PN) are shown, right-justified, as a 3-digit number with a **P** in front of them.



Display of e.g. program number 0

7.1 Programming procedure

The entire programming of the **IPM5/IPW5** is done by the steps described below.

Change to programming mode

Push the **[P]** key to change into programming mode. The unit goes to the lowest available program number. If the programming lock is activated, the key must be pushed for at least 1 second.



Example:

Change to programming mode by pushing key **[P]**. The first released program number (PN) appears, in this case PN0 .

Change between program numbers

To change between individual program numbers, keep the **[P]-key** pressed and push the **[▲]-key** for changing to a higher program number or the **[▼]-key** for changing to a lower number. By keeping the keys pushed, e.g. **[P] & [▲]**, the display will begin, after approx. 1 second, to automatically run through the program numbers.



Example:

A "3" is parameterised under PN1. Keep the **[P]-key** pushed and push the **[▲]-key** several times. PN1 appears in the display. Under this parameter the full scale of the input 2 can be changed.

Change to parameter

Once the program number appears in the display, you can push the **[▼]** or **[▲]-key** to get to the parameters set for this program number. The currently stored parameters are displayed.

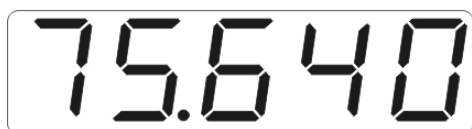

In this case, it is 75,640

Example:

By pushing the **[▼]** or **[▲]-key** , the currently stored value for PN1 appears in the display. In this case, it is 75,640.

Changing a parameter

After changing to the parameter, the **least significant digit** of the respective parameter flashes on the display. This value can be changed with the [**▼**] or [**▲**]-key. To move to the next digit, the [**P**]-key must be briefly pushed. Once the **most significant digit** has been set and confirmed with [**P**], the least significant digit will begin to flash again.



Example:

The 0 is flashing this is the least significant digit and asks if you want to change it. Let us assume the figure has to be changed from 75,640 to 75,000. Briefly push the [**P**]-key to move to the next digit. The 4 begins to flash. Change the figure by pushing [**▼**] or [**▲**]-key to change the digit from 4 to 0. Briefly push the [**P**]-key to

move on to the next digit. The 6 begins to flash. Change the digit by pushing [**▼**] or [**▲**]-key to move the 6 to a 0. Briefly push the [**P**]-key to move to the next digit. The 5 and 7 do not need to be changed.

Saving of parameters

All parameters must be acknowledged by the user by pushing the [**P**]-key for one second. The changed parameters are then taken over as the current operating parameters and saved in the EEPROM.

This is confirmed by **horizontal bars** lighting up in the display.



Example:

Save all parameters by pushing [**P**] for 2 seconds.

All the newly entered data are confirmed by the unit. If no confirmation is received, the relevant parameters have not been saved.



Example:

You receive confirmation from the unit that the changes have been saved through the appearance of horizontal bars in the middle segments.

7.1.1 Changing from programming mode into operating mode

If no key is pushed in the programming mode for about 7 seconds, the unit will return automatically to operating mode.

7.2 Linearisation

With the linearisation, the **IPM5** and **IPW5** offer the possibility of linearising strain gauge sensors for the display of the measurements and their further processing (analogue output), in addition to the 2-point calibration, a maximum of 30 calibration points can be programmed.

Example:

For the programming of e.g. 5 additional calibration points, the number 5 must be entered under PN100. Subsequently, for each of the calibration points, the pressure must be placed on the sensors, and the corresponding display value programmed under the following program numbers PN101–PN105. The sensor signal must be parameterised with a **strictly monotonous rising** configuration. A gap of at least +1 digit to the previous display value should be adhered to, otherwise it will be rejected through non-appearance of the storage notice, see **“Saving parameters”**.

Supporting point (PN)	Pressure [mbar]	Output transducer [mV/V]	Display before correction (IN)	Desired display (OUT)
2	0	0.05	2.5	0.0
101	15	0.33	16.5	15.0
102	30	0.62	31.0	30.0
103	40	0.92	46.0	40.0
104	60	1.14	57.0	60.0
105	75	1.47	73.5	75.0
1	100	2.00	100.0	100.0

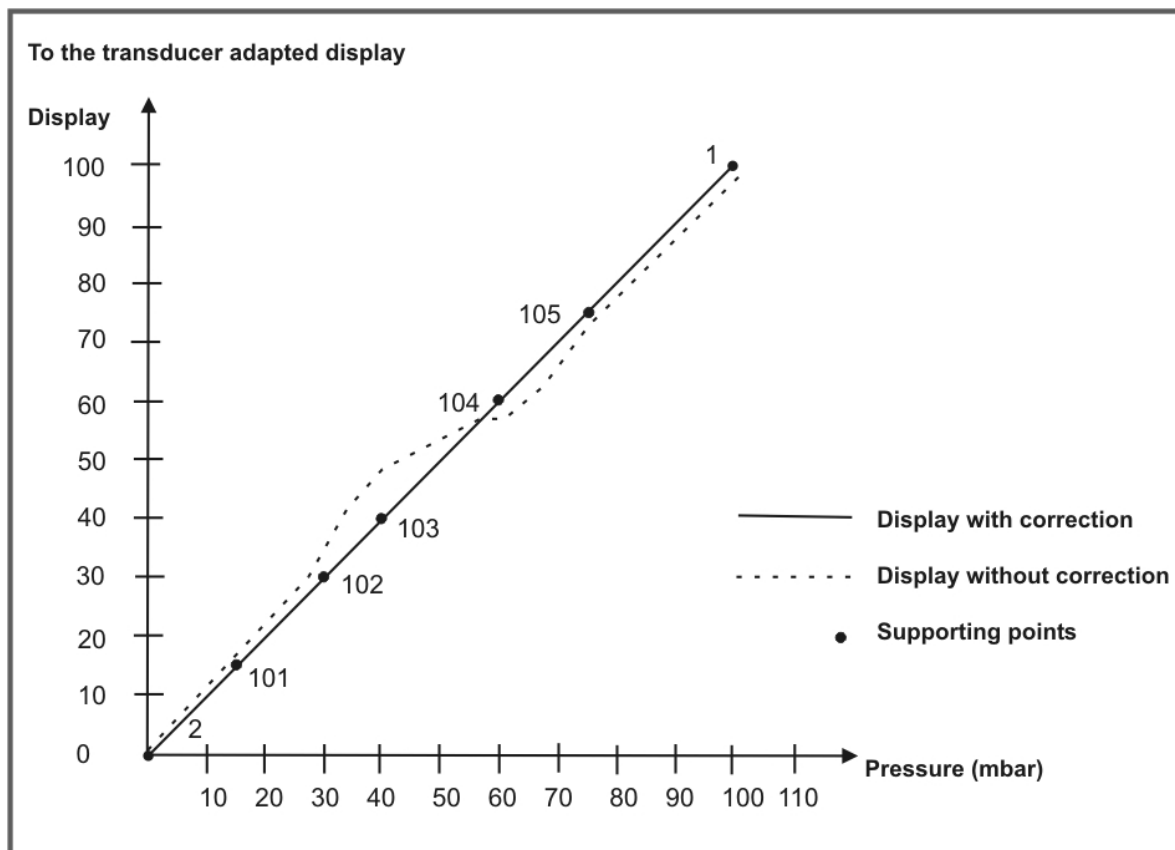

Linearisation of a pressure transducer for 0...100 mbar with a sensor of 2 mV/V.

8. Program number description

The **IPM5** and **IPW5** devices are parameterised or preset via program numbers because of the many different settings.

Strain gauges PN0

With this program number, the sensitivity of the strain gauge can be selected.

PN0 = 0, 1, 5, 6

With these settings, the maximum amplification (as with PN0=10) is preselected so that the output ranges of all possible sensor types can be recorded and evaluated.

PN0 = 2, 3, 4

This setting is based on pre-calibrated sensors, so that the start and end value are generally fixed. With a change to PN1 or PN2, the relevant binary calibration point is set to the factory setting. Should a calibration be subsequently performed, the calibration points will be checked for plausibility.

PN0 = 7, 8, 9, 10

With this setting, the calibration points are not fixed. When programming PN1 and PN2, the momentary measurement is taken from the input. PN1 and PN2 must be at least 1% of the measuring range apart. When programming PN1, the CAL wire (calibration point) is switched 2 seconds before taking over the measurement, and the set calibration point offset against the momentary binary value.

Setting of final value PN1

The end value for the display value and measurement may be larger or smaller than the offset setting PN2. It must differ from its measured value by at least 1% of the measuring range of the programmed offset value in PN2. If a standard sensor has been selected (PN0 = 2, 3 or 4), the measuring value determined ex works, 1mV/V, 2mV/V or 3.3mV/V, is entered. If PN0 is set at 7, 8, 9 or 10, the display switches – if available – its CAL wire, waits for 2 seconds and then takes over the preset calibration points based on the set calibration point PN10.

Offset setting PN2

With the offset setting PN2, the measured value must differ by at least 1% from the end value of PN1 calculated on the measuring range. If PN0 is selected at = 2, 3 or 4, the 0mV/V valued determined ex works is taken as the measurement in PN2. If PN0 is selected at = 7, 8, 9 or 10, the currently set measurement is taken as the calibration point.

Setting of decimal point PN3

With this program number, the desired number of places after the decimal point can be defined. The displayed decimal point moves from left to right or vice versa, with the value 0 being taken as a basis.

Offset displacement PN4

In this program number, the currently effective offset value can be checked. It can also be changed in this program number. With a transient taring operation (PN6 = 2, 3 or 5), the tare value is lost when restarting the unit, otherwise the value can be found in the provided configuration memory for the program number.

Taring function PN6

Suitable taring functions can be selected for various applications. These functions differ essentially in the method of saving the measured offset value. If no taring is selected, **PN6=0**, the offset value is always taken to be zero.

With permanent taring, **PN6=1**, the measured offset value in program number **PN5** is permanently saved in the user settings.

With transient taring, **PN6=2**, the offset value is retained only for the time the display is in operation. It is lost once the voltage is switched off. Since the integrated permanent memory has only limited writing capacity, this setting is used for very frequent taring operations (>10x a day) as with recipe balances. The trigger for the taring must be activated for 1-2 seconds.

With fast transient taring without a message using **PN6=3**, the taring is performed within a measuring cycle, whereby the offset value is lost when the unit is restarted. This mode is intended for fully automatic processes in which fast, frequent taring is required via a control system. The taring signal is filtered only with 50 ms and the taring is carried out without any message.

With the **PN6=4** setting, the taring is performed on the offset calibration point **PN2**. There is no shift in the offset value, but the linearisation of the sensor is changed directly. The currently set measurement for **PN2** is taken over. The trigger must previously be activated for at least 1-2 seconds.

With the static taring, **PN6=5**, the taring operation is performed with an upward slope and held until the signal is taken away again. After that, the absolute value is displayed. This function is especially suitable for checking tightness where the pressure loss and final pressure have to be measured.

Set value for taring PN7

For the display, a target value can be determined for the taring operation. As a rule, it is always calibrated to zero, i.e. zero is shown in the display following a taring operation. However, this value can also be changed to any other desired value. If 200 is entered under **PN7**, the offset value will shift so that, after taring, 200 is displayed. Both of these happen, of course, only on condition that the display is parameterised to the current measurement **PN15=1**. Where no trigger is selected for a taring (**PN8=0**), a taring operation is performed during programming.

Trigger for taring PN8

The taring set in the unit via **PN6** can be triggered via several sources and unit states. If **no trigger (PN8=0)** has been selected, but a taring function has been selected, taring is performed during programming of the target value **PN7**. If the **digital input** is selected **as a trigger (PN8=1)**, a taring operation is performed when applying a positive voltage. The same applies to the **4th key** on the display front, which can be selected for taring via **PN8=2 as triggering**. Here as well, the period of activation depends on the taring function. Another option is for the **system start-up** (power-up reset) to **trigger** a taring operation (**PN8=4**). For this of course, there is no activation period!

Calibration mode PN9

A distinction is made between a variety of **calibration modes**. The preset input behaviour is also entered into the calibration as selected under PN0.

With **autocalibration** to the calibration point (**PN=0**), a calibration is carried out only on **PN1** (end value). For this, the CAL relay is switched 2 seconds before the measurement is taken over. The calibration takes place on the basis of the calibration point. At 100%, it is taken over direct into **PN1**, otherwise a percentage conversion takes place.

With **semi-automatic calibration** to the calibration point, the CAL is first switched and the unit then waits at least 60 seconds for a further triggering of the calibration input. A calibration is made only to **PN1**!

With **automatic calibration** to **PN1** and **PN2 (PN9=2)**, the calibration is made first to the offset **PN2**. Then the CAL is switched and the unit waits 2 seconds before automatically calibrating the end value **PN1**.

With **semi-automatic calibration** to **PN1** and **PN2 (PN9=3)**, the offset **PN2** is, as above, first calibrated and the CAL then switched. After this, the unit is in a waiting loop for at least 60 seconds. During this period, the trigger must be activated again so that the end value **PN1** is taken over. Otherwise, the calibration is terminated without any changes being made.

With setting **PN9>3**, the relevant **calibration mode is triggered direct** after returning from the programming mode by confirming **PN9**.

Calibration point PN10

Calibration point **PN10** gives the **percentage target value** for the **end value calibration**. As a **rule, 100.00%** is preset here, in which case the measured end value is taken over directly. With **mass pressure sensors**, on the other hand, this value can be changed to **80.00%**, so that the determined measurement must be projected to 100.00%. All other percentages can also be preset, which means that a used reference weight does not have to correspond to the set end value.

Trigger for calibration PN11

The selected **calibration mode** in PN9 can be triggered in various ways. If **PN11=0** is set, the calibration can **no longer be triggered** by simply pressing a key or applying a binary signal. In this case, a **calibration** can only be triggered via the direct start with **PN9>7** or the system interface.

Either the digital input, the 4th key or a system start-up can serve as triggering. In particular, **PN11=4** is dealt with because no trigger is specified here with a **semi-automatic calibration**. For this reason, the calibration can be also continued via the **[P]-key**.

Transducer calibration PN12

The signal input has an **integrated self-calibration**. With this, the thermal **drift and ageing phenomena** in the signal input path can be neutralised. For areas in which **significant climate fluctuations** are to be expected, it is possible to diminish the drift influence of the analogue digital converter, via a cyclical calibration after **200 measurements**.

Display time PN13

The **display time** can be set between **0.1 and 10.0 seconds**, whereby the last measured measurement is taken over. There is no additional averaging for the display value beyond the individual measurement. If the measuring time is longer than the display time, the display change is delayed according to the set measuring time.

Measuring time PN14

During the **measuring time**, an **averaging process** takes place. With the **set measuring time**, the **existing outputs** like analogue output, calibration points and value transmitting function are **updated**.

Display mode PN15

Via the **display mode**, the **default display** can be defined. The current measurand, the min-value, max-value, Hold-value or absolute value (without PN5) can be displayed.

Trigger for display change PN16

Via a **definable trigger**, a **specific display change** can be preset. Either the display can change back and forth between the absolute value (with PN5) and the current display value, or it can switch to a conversion factor or, with a min or max display, can reset the corresponding value. In the latter case, the min- and max-values are reset and overwritten with the current measurand until the trigger is returned again. **PN16=8** has a special status, because here no min/max-values can be called up via **[▼] or [▲]-key**. This mode is particularly necessary with **calibrated balances** due to the possibility of occasional manipulation via the **[▼] or [▲]-keys**.

Conversion value PN17

The **conversion value** can only be used on calculations in which **PN2=0**. With **PN17**, a **second end value** can be preset, which is offset with the current measurement. This is used, for example, for a conversion to a price. For example: 100kg of product A cost € 230, so **PN1=100.00** and **PN17=230.0**.

Decimal point for conversion value PN18

For the **conversion value**, a **decimal point** can be defined so that the conversion value can move in a different dimension.

Analog output PN20, PN21, PN22 and PN23

The parameters of the **analog output** are related to the scale of the display and are updated cyclically with the **measuring time**. Via **PN22=0**, the analog output can be **deactivated**, whereby it stops at a starting value after a restart of the device.

With **PN22>0**, the analog output can be assigned to **various sources** (current measurand, min-value, max-value, Hold-value, absolute value without tare, binary converter value), whereby the preset range in PN20 and PN22 always relates to the particular scaled value. PN23 determines the output signal, either 0-20 mA, 4-20 mA or 0-10 VDC.

Safety settings, user level PN50 bis PN53

With the parameters in the security settings, access to the program numbers is regulated through the setting of various user levels. The user levels divide the access into various levels. The user is only given access to the settings authorised by the system operator, such as the setting of thresholds. The lower the figure for the user level given under PN52, the lower the level of security of the unit parameters against user intervention. The plant operator can (if necessary) also block these settings against access by the operating staff by means of a given authorisation code for the user level in PN53. Only when the value of PN53 is parameterised in PN50 the plant operator has access to the parameters authorised for him in the user level.

Examples:

User level (PN=)		0	1	2	3	4	5	6	7	8
Access to:	PN									
Programming lock	50	X	X	X	X	X	X	X	X	X
Serial number	200	X	X	X	X	X	X	X	X	X
Display brightness	19	X	X	X	X	X	X	X	X	
Threshold value	61, 71, ...	X	X	X	X	X	X	X		
Switching point parameter	59...95	X	X	X	X	X	X			
Set value for taring	7	X	X	X	X	X				
Interfaces parameter (Device option)	32...34	X	X	X	X					
Analog output parameter (Device option)	20...23	X	X	X	X					
Measuring input parameter	0...18	X	X	X						
Linearisation parameter for measuring input	100...130	X	X	X						
Release code / user level	51, 52, 53	X								

The parameterised user level PN52 is active as long as the authorisation code PN51 and programming lock PN50 are different. On delivery both parameters are set to 0000, so that the programming lock is deactivated.

When changing to programming mode, the device switches to the first authorised program number. If the user level PN52 is parameterised at =3, for example, access to the program numbers of the calibration points is authorised but changing the measuring input (PN0) is not possible at this user level.

In order to obtain access to all program numbers at a later stage (corresponds to user level 0), the 4-digit locking code entered under PN51 must, in order to gain authorisation under PN50, be entered again and confirmed by activating button **[P]** for around 1 second. Access can then be made to all program numbers.

Caution! If the authorisation code becomes lost, the unit can be set to the default value 0000 at the manufacturer's without any data loss.

Threshold value behaviour of LED display PN59

In the event of a failure of the alarm outputs set under the setpoint parameters, a flashing of the display can be triggered in order to intensify the optical effect. The flashing of the display can be parameterised to the four different alarms. This function can also be utilised where no relays exist.

Switching points PN60 to PN95

You can influence the behaviour of the setpoint via different program numbers. The data refer to the scaled measurement and are updated with the set measuring time. A description of the various parameters is given in section **“6.2 Relays”**.

The program numbers are also available when no relays are carried out in the unit. In such cases, only the relevant alarm LED light up on the front of the display. Furthermore the flash function (PN59) of the digital display can be switched to a freely selectable combination of the alarms.

Linearisation PN100 to 130

Through the linearisation, the user has the possibility to linearise a non-linear sensor signal. A detailed description can be found in the chapter on calibration modes.

Serial number PN200

Under this program number, you can call up the serial number that allows allocation to the production process and the manufacturing procedure. This parameter can only be viewed.

8.1 Program number description

The program table lists all the program numbers (PN) with their function, range of values, default values and user level.

PN	Function	Range of value	De- fault	User- level
Channel 1				
0	Measuring input Parameter < 5 do not necessarily need a sensor signal for calibration Parameter > 4 need a sensor signal for calibration	0 = automatic sensor detection 1 = semi-automatic sensor detection 2 = 1 mV/V 3 = 2 mV/V 4 = 3.3 mV/V 5 = automatic sensor detection 6 = semi-automatic sensor detection 7 = 1 mV/V 8 = 2 mV/V 9 = 3.3 mV/V 10 = 6 mV/V	10	2
1	Final value / Fullscale	-9999...99999	10000	2
2	Zero point / Offset	-9999...99999	0	2
3	Places after decimal point	0...4	none	2
5	Offset displacement	-9999...99999	0	2
6	Taring function	0 = no taring 1 = permanent taring 2 = transient taring 3 = quick, transient taring without report 4 = permanent taring onto PN2 5 = static taring at triggering	1	2
7	Set value for taring A direct taring is carried out, if PN8=0.	-9999...99999	0	4
8	Triggering for taring	0 = none 1 = digital input 2 = 4th key 3 = digital input or 4th key 4 = system start 5 = combination 1 & 4 6 = combination 2 & 4 7 = combination 3 & 4	0	2
9	Calibration mode for automatic operation: Calibration in % only onto final value PN1 Calibration in PN onto offset PN2 and final value PN1	0 = autocalibration to % 1 = semi-automatic to % 2 = autocalibration to PN 3 = semi-automatic to PN 4 = start mode 0 5 = start mode 1 6 = start mode 2 7 = start mode 3	2	2

PN	Function	Range of value	De- fault	User- level
10	Balance point in % IPM5 IPW5	0.01 ... 100.00 0.01 ... 100.00	80.00 100.0	2
11	Trigger for calibration	0 = none 1 = digital input 2 = 4th key 3 = digital input or 4th key 4 = system start 5 = combination 1 & 4 6 = combination 2 & 4 7 = combination 3 & 4	0	2
12	Transducer calibration	0 = no transducer calibration 1 = at system start 2 = every 200 measurements	0	2
General settings				
13	Display time	0.1...10.0	1.0	2
14	Measuring time	0.01...10.00	1.00	2
15	Display mode	1 = current measurand 2 = min-value 3 = max-value 4 = Hold-value 5 = absolute value	1	2
16	Trigger for display change	0 = none 1 = absolute value static on digital input 2 = absolute value static on 4th key 3 = absolute value static on 1 or 2 4 = none 5 = conversion value on digital input	0	2
17	Conversion value equals with PN1	-9999...99999	1	2
18	Decimal point for conversion value	0...4	0	2
19	Display brightness	0...9 (0=bright / 9=dark)	3	7
Analog output				
20	Final value / fullscale	-9999...99999	10000	4
21	Initial value / offset	-9999...99999	0	4

PN	Function	Range of value	De- fault	User- level
Analog output				
22	Analog output	0 = deactivated 1 = current measurand 2 = min-value 3 = max-value 4 = Hold-value 5 = absolute value	1	4
23	Signal selection	0 = 0-10 VDC 1 = 0-20 mA 2 = 4-20 mA	2	4
25	Disturbance behaviour of the analog output	0 = run onto limit values (as before) 1 = switch to final value at exceedance of output area 2 = switch to initial value at exceedance of output area (PN20/21) 3 = switch to highest value (0x0000) at exceedance of output area (PN20/21) 4 = switch to smallest value (0x0000) at exceedance of output area (PN20/21) 5 = switch to final value at converter, over-/underflow, wire break (bars) 6 = switch to initial value at converter, over-/underflow, wire break (bars) 7 = switch to highest value (0xFFFF) at converter, over-/underflow, wire break (bars) 8 = switch to smallest value (0xFFFF) at converter, over-/underflow, wire break (bars)	5	4
Interface				
34	Switchover of interface behaviour	0 = standard operation 1 = transmitting operation	0	4
35	Measurand that has to be transmitted	1 = current measurand 2 = min-value 3 = max-value 4 = Hold-value 5 = absolute value	1	4

PN	Function	Range of value	De- fault	User- level
Safety settings				
50	Programing lock	0000...9999	0000	8
51	Release code for all parameter	0000...9999	0000	0
52	User level	0...8	8	0
53	Release code for user level 0000 = user level always released	0000...9999	0000	0
Threshold behaviour of LED-display				
59	Display flashing (approx. 0.5 seconds) No flashing Flashing at switchpoint 1 Flashing at switchpoint 2 Flashing at switchpoint 3 Flashing at switchpoint 4 Flashing at switchpoints 1 and 2 Flashing at switchpoints 3 and 4 Flashing at switchpoints 1, 2, 3 and 4	0 no flashing 1 flashes at 1 2 flashes at 2 3 flashes at 3 4 flashes at 4 5 flashes at 1 or 2 6 flashes at 3 or 4 7 flashes at 1, 2, 3 or 4	0	5
Switchpoint 1				
60	Switchpoint 1	0 = deactivated 1 = current measurand 2 = min-value 3 = max-value 4 = Hold-value 5 = absolute value 6 = sensor error	1	5
61	Threshold	-9999...99999	1000	6
62	Hysteresis	0...99999	1	5
63	Operation type quiescent current / operating current	0 = quiescent current 1 = operating current	1	5
64	Switching delay	0.0...10.0 seconds	0.0	5
65	Type of delay	0 = none 1 = switching-on delay 2 = switching-off delay 3 = switching-on/-off delay	1	5
Switchpoint 2				
70	Switchpoint 2	0 = deactivated 1 = current measurand 2 = min-value 3 = max-value 4 = Hold-value 5 = absolute value 6 = sensor error	1	5

PN	Function	Range of value	De- fault	User- level
71	Threshold	-9999...99999	1000	6
72	Hysteresis	0...99999	0	5
73	Operation type quiescent current / operating current	0 = quiescent current 1 = operating current	1	5
74	Switching delay	0.0...10.0 seconds	0.0	5
75	Type of delay	0 = none 1 = switching-on delay 2 = switching-off delay 3 = switching-on/-off delay	0	5
Switchpoint 3				
80	Switchpoint 3	0 = deactivated 1 = current measurand 2 = min-value 3 = max-value 4 = Hold-value 5 = absolute value 6 = sensor error	1	5
81	Threshold	-9999...99999	1000	6
82	Hysteresis	0...99999	0	5
83	Operation type quiescent current / operating current	0 = quiescent current 1 = operating current	1	5
84	Switching delay	0.0...10.0 seconds	0,0	5
85	Type of delay	0 = none 1 = switching-on delay 2 = switching-off delay 3 = switching-on/-off delay	0	5
Switchpoint 4				
90	Switchpoint 4	0 = deactivated 1 = current measurand 2 = min-value 3 = max-value 4 = Hold-value 5 = absolute value 6 = sensor error	1	5
91	Threshold	-9999...99999	1000	6
92	Hysteresis	0...99999	0	5
93	Operation type quiescent current / operating current	0 = quiescent current 1 = operating current	1	5
94	Switching delay	0.0...10.0 seconds	0,0	5

PN	Function	Range of value	De- fault	User- level
95	Type of delay	0 = none 1 = switching-on delay 2 = switching-off delay 3 = switching-on/-off delay	0	5
Linearisation				
100	Number of additional switchpoints	0...30	0	2
101 to 130	Switchpoints 1...30	-9999...99999		2
System information (not adjustable)				
200	Serial number	0...99999	0	8
204	Event counter / Configuration counter	0...9999	XXXX	8

9. Reset to default values

To return the unit to a defined basic state, a reset can be carried out to the default values.

The following procedure should be used:

- Switch off the power supply
- Press button **[P]**
- Switch on the power supply and press **[P]** for approx. further 2 seconds.



With reset, the default values of the program table are loaded and used for subsequent operation. This puts the unit back to the state in which it was supplied.

Caution!

- This is only possible when the programming lock PN50 allows access to all program numbers (PNs) or "HELP" is shown in the display.
- All application-related data are lost.

10. Error elimination

The following list gives the recommended procedure for dealing with errors and locating their possible cause.

	Error description	Measures
1.	The display shows a permanent overflow. 	<ul style="list-style-type: none"> The input signal is too high, check the measuring circuit. A wire break happened or the device was not connected correctly. The measuring input is not scaled correctly, so that the display should show a higher value than 99999.
2.	The display shows a permanent underflow. 	<ul style="list-style-type: none"> The input signal is too small, check the measuring circuit. The measuring input is not scaled correctly, so that the display should show a higher value than -9999.
3.	The display shows HELP in the 7-segment display.	<ul style="list-style-type: none"> The device located an error in the configuration memory, carry out a reset to default values and reconfigure the device according to your application.
4.	Program numbers for parameterisation of the input are not available.	<ul style="list-style-type: none"> The programming lock is adjusted to an user level that does not allow an access. A different sensor type was parameterised under PN1, so that the desired program number could not be adjusted.
5.	The device shows ERR1 in the 7-segment display.	<ul style="list-style-type: none"> Please contact the manufacturer if errors of this kind occur.