

ITFT1 – full graphic indicator for panel-mounting in 96x48 mm (WxH) Multifunctional measuring input: direct voltage, direct current, Pt100(0), Thermocouple, frequency, rotational speed, counter

- presentation of metered value of -1999...9999 Digits
- digit height approx. 15 mm
- selectable colour for measurand and background: red, green, white, black, orange
- minimal installation depth: 25 mm without plug-in terminal, with transformer 42 mm
- display panel 2,4", 320x240 Pixel
- display of metering point description and signal description
- adjustable signs for physical dimensions
- min/max value recording
- 9 adjustable supporting points
- display flashing at threshold value exceedance/undercut
- Tara function
- programming interlock via access code
- protection class IP65 at the front
- pluggable screw terminal
- 2 switching points (changer)
- option: interface RS485 with Modbus protocol
- accessories: PC-based configuration kit PM-TOOL with CD & USB adapter

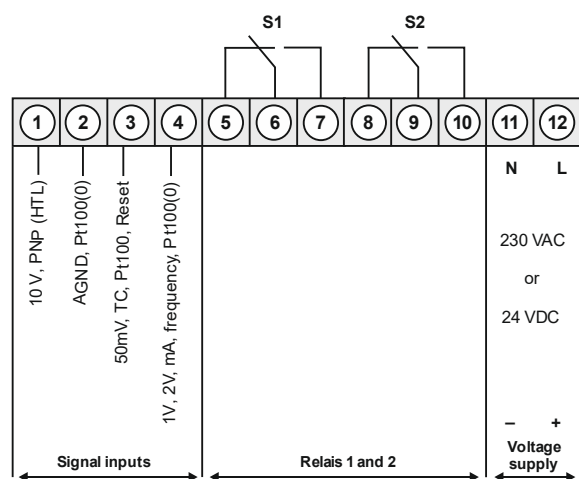

• Multifunctional measuring input



Supply 230 VAC

Supply 24 VDC galv. isolated

ORDER NUMBER **EUR**
 (without options)

ITFT1-11U.000X.572A **238.30**

ITFT1-11U.000X.772A **248.90**

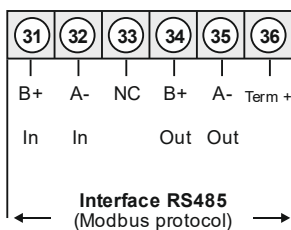

• Order key options

IT	F	T	1-	1	1	U.	0	0	0	X.	5	7	2	A
IT	F	T	1-	1	1	U.	0	0	0	X.	7	7	2	A

4 Interface RS485 – galv. isolated (only possible without relay)

58.30

• Parameterisation software

PC-based configuration software PM-TOOL for a simple adjustment,
incl. CD & USB adapter. Programming happens on the rear side via micro USB plug.

PM-TOOL-USB

30.70

• Technical data

Housing	Dimensions	W96 x H48 x D 25 mm, (with plug-in terminal 47 mm, devices with transformer 42 mm)
	Panel cut-out	92.0 ^{+0.8} x 45.0 ^{+0.6} mm
	Fixing	screw elements for a wall thickness of up to 3 mm
	Housing material	PC Polycarbonate, black, UL94V-0
	Sealing material	EPDM, 65 Shore, black
	Protection class	at the front side IP65 standard, at the rear side IP00
	Weight	approx. 100 g
Connection	plug-in terminal; wire cross section up to 2.5 mm ² push-in terminal; wire cross section up to 0.75mm ² for interface RS485	

Display	Display	fullgraphic ITFT-display with 320x240 Pixel Digit
	height	15 mm
	Presentation of metered value	-1999 to 9999
	Measurand background colour	Red, Green, White, Black or Orange (selectable)
Limit values	optical display flashing	

Measuring input

Signal	Measuring range	Measuring range	Resolution
Voltage	0...10 V Ri > 100 kOhm	0...12 V	≥ 14 bit
Voltage	0...2 V Ri ≥ 10 kOhm	0...2.2 V	≥ 14 bit
Voltage	0...1 V Ri ≥ 10 kOhm	0...1.1 V	≥ 14 bit
Voltage	0...50 mV Ri ≥ 10 kOhm	0...75 mV	
Current	4...20 mA Ri = ~125 Ohm	1...22 mA	
Current	0...20 mA Ri = ~125 Ohm	0...22 mA	
Pt100-3-wire	-50...200°C	-58...392°F	0.1°C / 0.1°F
Pt100-3-wire	-200...850°C	-328...1562°F	1°C / 1°F
Pt1000-2-wire	-200...850°C	-328...1562°F	1°C / 1°F
Thermo K	-270...1350°C	-454...2462°F	1°C / 1°F
Thermo S	-50...1750°C	-328...3182°F	1°C / 1°F
Thermo N	-270...1300°C	-454...2372°F	1°C / 1°F
Thermo J	-170...950°C	-274...1742°F	1°C / 1°F
Thermo T	-270...400°C	-454...752°F	1°C / 1°F
Thermo R	-50...1768°C	-58...3214°F	1°C / 1°F
Thermo B	80...1820°C	176...3308°F	1°C / 1°F
Thermo E	-270...1000°C	-454...1832°F	1°C / 1°F
Thermo L	-200...900°C	-328...1652°F	1°C / 1°F
Frequency	0...10 kHz	0...10 kHz	0.001 Hz / ±1
NPN	0...3 kHz	0...3 kHz	0.001 Hz / ±1
PNP	0...1 kHz	0...1 kHz	0.001 Hz
Rotational speed	0...9999 1/min	0...9999 1/min	0.001 1/min
Counter	0...9999 (prescaler up to 1000)		

Pulse input	TTL Low <2 V / High >3 V	HTL/PNP Low <6 V / High >8 V
	NPN Low <0.8 V / High via resistance	Namur Low <1.5 mA / High >2.5 mA

Reset input	active <0.8 V
--------------------	---------------

Relay	with changeover contact 30 VDC / 2 A resistive burden
--------------	---

Interface	RS485	9.600 Baud, no parity, 8 DataBit, 1 StopBit, wire length max. 1000m
	Protocol	Modbus with ASCII or RTU-protocol

Measuring error	Standard	0.2% of measuring range ± 1 Digit
	Pt100 / Pt1000	0.5% of measuring range ± 1 Digit
	Thermocouples	0.3% of measuring range ± 1 Digit

Accuracy	Reference junction	± 1°C
	Drift of temperature	100 ppm/K
	Measuring time	0.01 to 2.0 seconds
	Measuring rate	approx. 1/s with temperature sensor, approx. 100/s with standard signals
	Measuring principle	U/F conversion
Resolution	approx. 14 Bit at 1s measuring time	

Power pack	Supply	230 VAC 50/60 Hz, ≤ 3 VA
		24 VDC ± 10% galvanically isolated, ≤ 1 VA

Memory	EEPROM	Data preservation ≥ 100 years at 25°C
---------------	--------	---------------------------------------

Ambient conditions Working temperature -20 to + 50°C
Storing temperature -30 to + 70°C
Weathering resistance relative humidity 0-85% on years average without dew

EMV CE-identification EN 61326
Conformity according directive 2014/30/EU

Safety regulations According to low voltage directive 2013/35/EU; EN 61010; EN 60664-1

Housing:

