



Read these instructions before using the product and retain for future information.

### IPAQ R460

#### ► Before Startup



When operating the signal converter, certain parts of the module can carry dangerous voltage! Ignoring the warnings can lead to serious injury and/or cause damage!

The signal converter should only be installed and put into operation by qualified staff. The staff must have studied the warnings in these operating instructions thoroughly.

The signal converter may not be put into operation if the housing is open.

In applications with high operating voltages sufficient distance and isolation as well as shock protection must be ensured.

Safe and trouble-free operation of this device can only be guaranteed if transport, storage and installation are carried out correctly and operation and maintenance are carried out with care.



Appropriate safety measures against electrostatic discharge (ESD) should be taken during range selection and assembly on the transmitter.

#### ► Short description

The programmable transmitter is designed for operating various industrial sensors. The measured values are converted into a current or voltage signal. The configuration can be done either via DIP switch for preference measuring ranges or extensive ranges via a USB-interface with the PC configuration program INOR-Set.

The 3-way isolation guarantees reliable decoupling of the sensor circuit from the processing circuit and prevents linked measurement circuits from influencing each other. The auxiliary power can either be supplied via the connection terminals or via the In-Rail-Bus connector (see Accessories).

#### ► Configuration and startup

##### Configuring with DIP switch

Use the DIP switches to configure the device, according to table. Via the DIP switches you can select only a limited number of sensors. A wider range of sensors you can select via software configuration.

##### Configuring with software INOR-Set

Use the software INOR-Set to configure the device. Changes to the configuration and parameterization data can be performed both during operation with a connected measuring circuit and in a disconnected state. The INOR-Set software is free and can be downloaded from our website.

The device is equipped with a programming socket on the front. Use the INOR-Set USB Converter (Order no.: 70USBIM010) for connecting the device to the PC. To change the configuration and parameterization DIP switch S1- 1, 2, 3 have to be set ON!

#### Commissioning Function

The Commissioning Function with a stepped keystone signal on output supports a fast and simple testing of cabling and connection of downstream devices or measuring adjustment. Press the function button located behind the front cover for longer than 3 seconds. The Commissioning Function will be indicated with a yellow LED (quick double off).  
Output value:

Output	0 %	↗	50 %	↗	100 %	↘	50 %	↘
Time	5 s	3 s	3 s	3 s	5 s	3 s	3 s	3 s

The stepped keystone signal is output continuously. Exit the Commissioning Function by pressing the button again for 3 seconds or power off.

#### Teach-In Function for Potentiometer, Resistor and mV- Input

The Teach-In function can be used to teach in the start value and end value. There are two ways of the Teach-In function:

- Automatic set up mode (Auto Teach-In)
- Manual Teach-In of the start and end value (Manual-Teach-In)

The taught-in values remain stored under the Teach-In setting. The start value is 0 % and the end value is 100 % by default.

#### Starting the Teach-In Function

Use the function button located behind the front cover of the device to teach in the device (use screw driver to push).

1. Configure the device using the DIP switches on the side of the device.
2. Press the function button for longer than 3 seconds.  
→ The yellow LED will flash quickly
3. **Auto Teach-In:** Set input signal to both min and max range limits as often as desired. Start value and end value will be automatically determined and recorded.  
or  
**Manual Teach-In:** Set input signal to first range limit and press the function button for around 0.5 seconds. Set second limit and press the function button for around 0.5 seconds. This can be repeated as often as required. The value of the last two keystrokes will be stored for start value and end value.

#### Ending the Teach-In, Saving the Start Value and End Value

Press the function button for longer than 3 seconds. Release the button when the yellow LED lights up constant. The values are stored. The green LED indicates the successfully storage.

#### Ending the Teach-In without Saving the Start Value and End Value

Press the function button for longer than 6 seconds. Release the button when the yellow LED starts to flash again after lit up constant. The values are ignored and not stored.  
Or switch off the device. The values are not stored.

#### Teach-In Fault

If the span between the start value and the end value is too small, the red LED will flash slowly after saving the values (configuration error). In case of a fault, the Teach-In function must be performed again in its entirety.

#### ► Technical Data

Input	Span min.	Error
Pt100, Pt200, Pt500, Pt1000	10 K	< 0.1 K + 0.05 % meas. val.
Ni100, Ni200, Ni500, Ni1000	10 K	< 0.2 K + 0.05 % meas. val.
KTY (29 types)	25 K	< 0.3 K + 0.05 % meas. val.
Resistor 0...5000Ω	100 Ω	< 0.1 Ω + 0.02 % meas. val.
Sensor current / connection	0.2 mA / 4-wire, 3-wire, 2-wire	
Cable resistance	< 100 Ω per wire, manual compensation for 2-wire connection programmable	
TC Sensor E, J, K, L, N, R, S, T, U / B, C, D	50 K / 100 K	< 0.3 K + 0.08 % meas. val.
Cold junction compensation	intern, extern Pt100, uncompensated, manual setting (Error of cold junction compensation internal < 1.5 K)	
±100 mV, ±1000 mV	5 mV, 50 mV	< 50 μV + 0.02 % meas. val.
Poti 100 Ω to 50 kΩ	10 %	< 0.05 %

Output	Current	Voltage
Output signal	0...20 mA 0...10 mA 4...20 mA 2...10 mA	0...10 V 0...5 V 2...10 V 1...5 V
Load	≤ 12 V (600 Ω at 20 mA)	≤ 5 mA (2 kΩ at 10 V)
Residual ripple	< 10 mV <sub>ms</sub>	
Transfer range	0 to 102.5 % (3.8 to 20.5 mA at output 4 to 20 mA)	
Error signal	Transfer characteristic rising / falling	
	Sensor- / wire break, error signal programmable	

General data	
Transmission error	< 0.1 % full scale
Temperature coefficient <sup>2)</sup>	< 100 ppm/K
Measurement rate	4 / s
Response time T99	250 ms
Test voltage	3 kV, 50 Hz, 1 min. Input against output against power supply
Working voltage <sup>3)</sup>	600 V AC/DC for overvoltage category II and contamination class 2 acc. to EN 61010-1
Protection against dangerous body currents <sup>3)</sup>	Protective Separation by reinforced insulation acc. to EN 61010-1 up to 300 V AC/DC for overvoltage category II and contamination class 2 between input and output and power supply.
Ambient temperature	Operation -25 °C to +70 °C (-13 to +158 °F) Transport and storage -40 °C to +85 °C (-40 to +185 °F)
Power supply	24 V DC 16.8 V ... 31.2 V, approx. 0.8 W
EMV <sup>4)</sup>	EN 61326-1
Construction	6.2 mm (0.244") housing, protection type: IP 20 mounting on 35 mm DIN rail acc. to EN 60715
Connection	Solid: 0.5 mm <sup>2</sup> - 4 mm <sup>2</sup> / AWG 20-12 Fine-stranded: 0.5 mm <sup>2</sup> - 2.5 mm <sup>2</sup> / AWG 20-14 Stripped length: 8 mm / 0.3 in Screw terminal torque 0.6 Nm / 5 lbf in
Weight	Approx. 70 g

- 1) Factory setting:  
Input: Pt100, 0...100°C, 4-wire-sensor connection  
Output: 0...20 mA, Characteristic rising, error signal 22 mA
- 2) Average TC in specified operating temperature range
- 3) As far as relevant the standards and rules mentioned above are considered by development and production of our devices. In addition relevant assembly rules are to be considered by installation of our devices in other equipment's. For applications with high working voltages, take measures to prevent accidental contact and make sure that there is sufficient distance or insulation between adjacent situated devices.
- 4) Minor deviations possible during interference

#### ► Dimensions

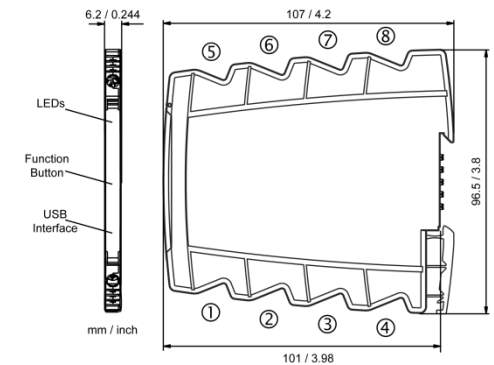

#### ► Mounting, Electrical Connection

The transmitter is mounted on standard 35 mm DIN rail

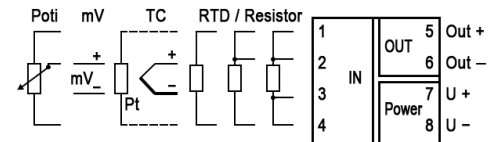

#### ► Order Information

Temperature Transmitter	Order No.
IPAQ R460	70R4600010

#### LIMITED WARRANTY

INOR Process AB hereby warrants that the Product will be free from defects in materials or workmanship for a period of **five (5) years** from the date of delivery ("Limited Warranty"). This Limited Warranty is limited to repair or replacement at INOR's option and is effective only for the first end-user of the Product. This Limited Warranty applies only if the Product:

1. is installed according to the instructions furnished by INOR;
2. is connected to a proper power supply;
3. is not misused or abused; and
4. there is no evidence of tampering, mishandling, neglect, accidental damage, modification or repair without the approval of INOR or damage done to the Product by anyone other than INOR.

Delivery conditions are based upon the „GENERAL CONDITIONS FOR THE SUPPLY OF PRODUCTS AND SERVICES OF THE ELECTRICAL AND ELECTRONICS INDUSTRY“  
Subject to change!

ICS Schneider Messtechnik GmbH  
Briesestraße 59  
D-16562 Hohen Neuendorf / OT Bergfelde

Tel.: 03303 / 50 40 66  
Fax: 03303 / 50 40 68

info@ics-schneider.de  
www.ics-schneider.de

Set the input and output ranges with DIP switches (● = ON) as indicated in the following table:

DIP S1 ● = on					Input
1	2	3	4	5	Pt100
●					Pt1000
	●				Ni100
●		●			Resistor
				●	2-wire
			●		3-wire
				●	4-wire
●	●	●	●	●	Potentiometer
●	●				Type J
		●			Type K
					CJC internal
			●		CJC external (Pt100)
				●	CJC off
●	●				± 100mV
●	●	●			mV x 10
●	●	●			PC (USB) Setting

DIP S2				Output
7	8	9	10	0 ... 20 mA
●				4 ... 20 mA
	●			0 ... 10 V
●				0 ... 5 V
				<b>Characteristic</b>
				rising
				falling
				<b>Error Message</b>
				signalize
				not signalize

● = ON

Factory settings: all switches in position OFF

### LED indication

The transmitter has a green and a red/yellow LED on front panel.

LED		Announcement
green	continuous	Power LED, normal operation
green	flashing	Over/under range on input
yellow	quick flashing	Teach-In mode active
yellow	slow double flashing	Commissioning Function active
red	flashing	Sensor break or configuration error
red	continuous	Device error, replacement is necessary

DIP S1						Start Value				
6	7	8	9	10	°C	°F	Ω	Pot	mV	
●					-200	-328	0	0%	-100	
	●				-175	-283	50	1%	-90	
●	●				-150	-238	100	2%	-80	
		●			-125	-193	150	3%	-70	
●		●			-100	-148	200	4%	-60	
	●	●			-75	-103	250	5%	-50	
●	●	●			-50	-58	300	6%	-45	
			●		-25	-13	350	7%	-40	
					0	32	400	8%	-35	
●			●		25	77	450	9%	-30	
	●		●		50	122	500	10%	-25	
●	●		●		75	167	550	11%	-20	
		●	●		100	212	600	12%	-15	
●	●	●			125	257	650	13%	-10	
	●	●	●		150	302	700	14%	-5	
●	●	●	●		175	347	750	15%	0	
			●		200	392	800	20%	5	
●			●		225	437	850	25%	10	
	●		●		250	482	900	30%	15	
●	●		●		275	527	950	35%	20	
		●	●		300	572	1000	40%	25	
●	●		●		350	662	1500	45%	30	
	●	●	●		400	752	2000	50%	35	
●	●	●			450	842	2500	55%	40	
		●	●		500	932	3000	60%	45	
●		●	●		550	1022	3500	65%	50	
	●	●	●		600	1112	4000	70%	60	
●	●	●	●		650	1202	4500	75%	70	
		●	●	●	700	1292	-/-	80%	80	
●	●	●	●		800	1472	-/-	85%	90	
	●	●	●	●	900	1652	-/-	90%	-/-	
●	●	●	●	●	1000	1832		Teach In		

DIP S2						End Value				
1	2	3	4	5	6	°C	°F	Ω	Poti	mV
●						-125	-193	100	10%	-/-
	●					-150	-238	150	15%	-/-
●	●					-100	-148	200	20%	-/-
		●				-75	-103	250	25%	-/-
●		●				-50	-58	300	30%	-/-
	●	●				-25	-13	350	35%	-/-
●	●	●				0	32	400	40%	-/-
			●			25	77	450	45%	-/-
●		●				50	122	500	46%	-/-
	●	●				75	167	550	47%	-/-
						100	212	600	48%	100
●	●	●				125	257	650	49%	95
		●	●			150	302	700	50%	90
●	●	●				175	347	750	51%	85
	●	●	●			200	392	800	52%	80
●	●	●	●			225	437	850	53%	75
			●			250	482	900	54%	70
●			●			275	527	950	55%	65
	●		●			300	572	1000	56%	60
●	●		●			325	617	1050	57%	55
		●	●			350	662	1100	58%	50
●	●	●				375	707	1150	59%	45
	●	●	●			400	752	1200	60%	40
●	●	●	●			425	797	1250	61%	35
		●	●			450	842	1300	62%	30
●		●	●			475	887	1400	63%	25
	●	●	●			500	932	1500	64%	20
●	●	●	●			525	977	1600	65%	15
		●	●	●	550	1022	1700	66%	10	
●	●	●	●		575	1067	1800	67%	5	
	●	●	●	●	600	1112	1900	68%	0	
●	●	●	●	●	625	1157	2000	69%	-5	
								Teach In		

### Error diagnostic function on output

(other output ranges react analogous to the table)

Characteristic	Error	Output	Under range	Over range	Sensor break / invalid setting
rising S2-9 OFF	signalize S2-10 = OFF	0 ... 20 mA 4 ... 20 mA 0 ... 5 V 0 ... 10 V	0 mA 3.8 mA 0 V 0 V	20.5 mA 20.5 mA 5.125 V 10.25 V	22 mA 22 mA 5.5 V 11 V
	not signalize S2-10 = ON	0 ... 20 mA 4 ... 20 mA 0 ... 5 V 0 ... 10 V	0 mA 4 mA 0 V 0 V	20 mA 20 mA 5 V 10 V	0 mA 4 mA 0 V 0 V
falling S2-9 ON	signalize S2-10 = OFF	20 ... 0 mA 20 ... 4 mA 5 ... 0 V 10 ... 0 V	20.5 mA 20.5 mA 5.125 V 10.25 V	0 mA 3.8 mA 0 V 0 V	22 mA 22 mA 5.5 V 11 V
	not signalize S2-10 = ON	20 ... 0 mA 20 ... 4 mA 5 ... 0 V 10 ... 0 V	20 mA 20 mA 5 V 10 V	0 mA 4 mA 0 V 0 V	0 mA 4 mA 0 V 0 V