

Magnetic display For bypass level indicators Model BMD for nuclear power plants

KSR data sheet BMD for NPP

Applications

- Display bar for the visualisation of levels in combination with bypass level indicators
- Individual design and corrosion resistant materials make the products suitable for a broad range of applications
- Chemical, petrochemical, natural gas, offshore, shipbuilding, machine building, power generating equipment, power plants
- Process water and drinking water treatment, food industry, pharmaceutical industry

Special features

- Measured value display by means of rollers or flaps with permanent magnets
- Medium temperatures from -200 ... +450 °C
- Splash-proof
- Without power supply
- Hermetically sealed from the process

Description

The model BMD magnetic displays are used in combination with bypass level indicators for the display of levels. A magnetic system built into the float transmits the liquid level, contact-free, to the externally mounted display. In this are fitted, at 10 mm intervals, red/white plastic rollers or stainless steel flaps with bar magnets. Through the directional magnetic field of the permanent magnetic system in the bypass float, the magnetic rollers or flaps, through the wall of the bypass chamber, are turned through 180°. For an increasing level from white to red; for a falling level from red to white. Thus the magnetic display indicates the level of a vessel as a red column, without power supply.

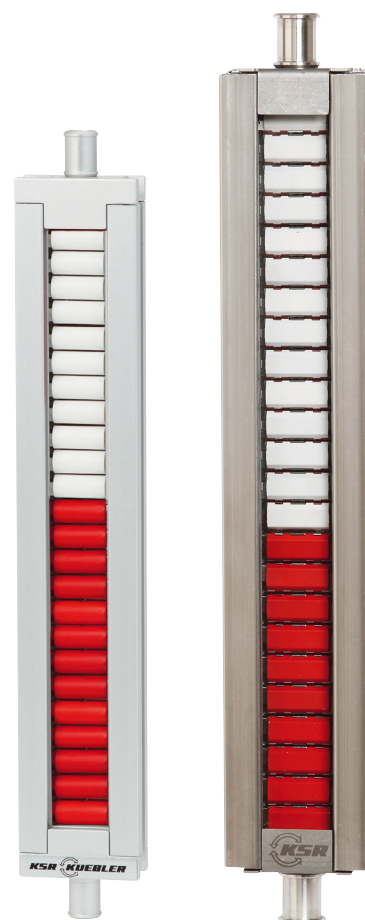

Magnetic display
Fig. left: Plastic rollers, model BMD-SA
Fig. right: Stainless steel flaps, model BMD-FR

An integrated T-slot serves for the fastening of further attachment parts such as scales, sensors and switches.

For selecting the optimum magnetic display (plastic rollers/stainless steel flaps, case, scale, measuring range etc.) we offer application-related technical advice.

Model overview

Magnetic display model	Description
BMD-SA	Plastic rollers in aluminium case, with T-slot
BMD-SR	Plastic rollers in stainless steel case with T-slot
BMD-FA	Stainless steel flaps in aluminium case, with T-slot
BMD-FR	Stainless steel flaps in stainless steel case with T-slot

Options

- Scale with adhesive foil
- Scale engraved aluminium
- Scale engraved stainless steel
- Scale in cm, mm or %
- Special scale
- Acrylic sight glass extender for insulation at low temperatures
- Purge gas connection
- Display elements in the colours red, white, black and yellow (others on request)

Magnetic display, plastic rollers in aluminium case, with T-slot, BMD-SA

Permissible temperature: -50 ... +200 °C

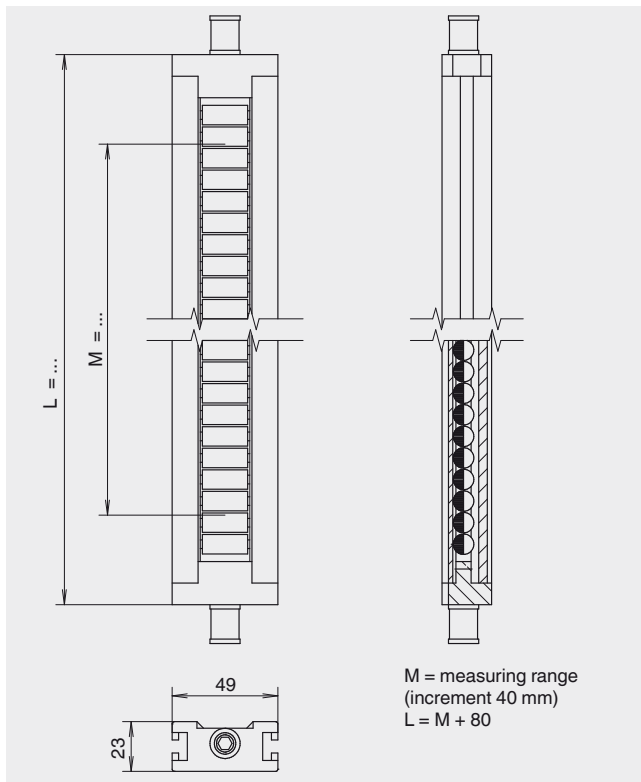

Specifications

Case	Aluminium, anodised
Length L	180 ... 6,000 mm
Display element	Plastic rollers, PBT, red/white
Indicator window	Polycarbonate

Magnetic display, plastic rollers in stainless steel case, with T-slot, BMD-SR

Permissible temperature: -50 ... +200 °C

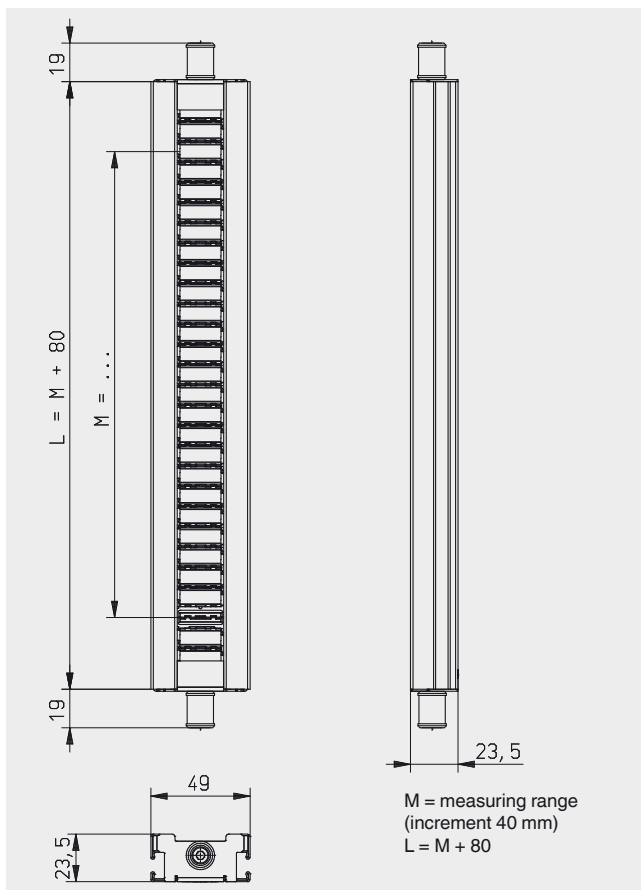

Specifications

Case	Stainless steel
Length L	180 ... 6,000 mm
Display element	Plastic rollers, PBT, red/white
Indicator window	Polycarbonate

Magnetic display, stainless steel flaps in aluminium case, with T-slot, BMD-FA

Permissible temperature: -200 ... +450 °C

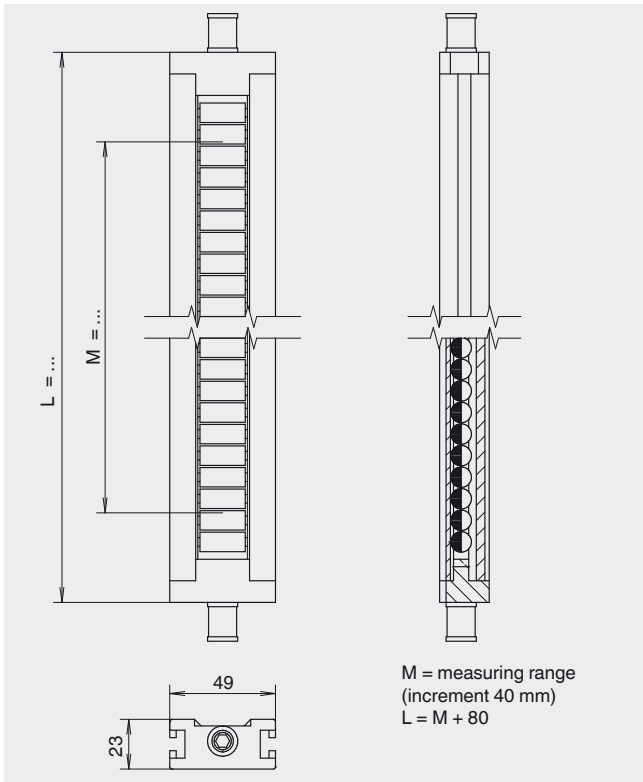

Specifications

Case	Aluminium, anodised
Length L	180 ... 6,000 mm
Display element	Stainless steel flaps, red/white
Indicator window	Glass

Magnetic display, stainless steel flaps in stainless steel case, with T-slot, BMD-FR

Permissible temperature: -200 ... +450 °C

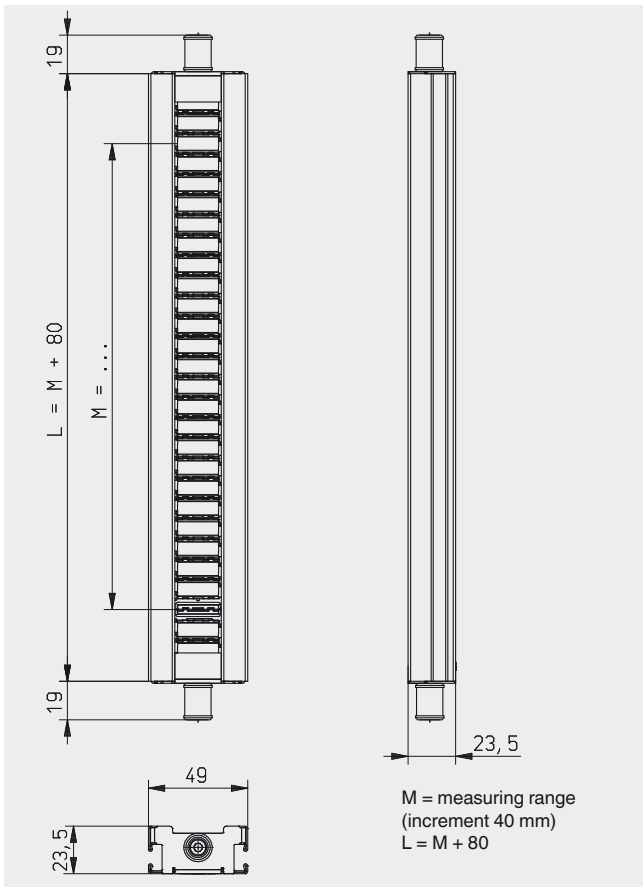

Specifications

Case	Stainless steel
Length L	180 ... 6,000 mm
Display element	Stainless steel flaps, red/white
Indicator window	Glass

Option

Scale (adhesive foil, aluminium or stainless steel)

Aluminium with adhesive foil, cm-graduation

max. ambient temperature for the adhesive foil: 100 °C

Aluminium or stainless steel engraved, graduation selectable

