

Optoelectronic level switch Model OLS-H / OLS-H-HT high-temperature For nuclear power plants

KSR data sheet OLS-H for NPP

Applications

- Chemical, petrochemical, natural gas, offshore industries
- Shipbuilding, machine building, refrigerator units
- Power generating equipment, power plants
- Process and drinking water treatment
- Wastewater and environmental engineering

Special features

- Temperature ranges from 0 ... +350 °C
- Pressure up to 176 bar
- Signal processing is made using a separate model OSA-S switching amplifier

Description

The model OLS optoelectronic level switches are used for the detection of limit levels in liquids. This is widely independent of physical characteristics such as refractive index, colour, density, dielectric constant and conductivity. Measurement is also done in small volumes.

The switches consist of an infrared LED and a phototransistor. The light of the LED is directed into a prism. So long as the sensor tip of the prism is in the gas phase, the light is reflected within the prism to the receiver. When the liquid in the vessel rises and wets approximately 2/3 of the glass tip, the infrared lightbeam into the liquid is interrupted and only a small portion reaches the receiver. This difference is evaluated by the electronics and triggers a switching operation.

The instruments are very robust and designed for rough operating conditions.

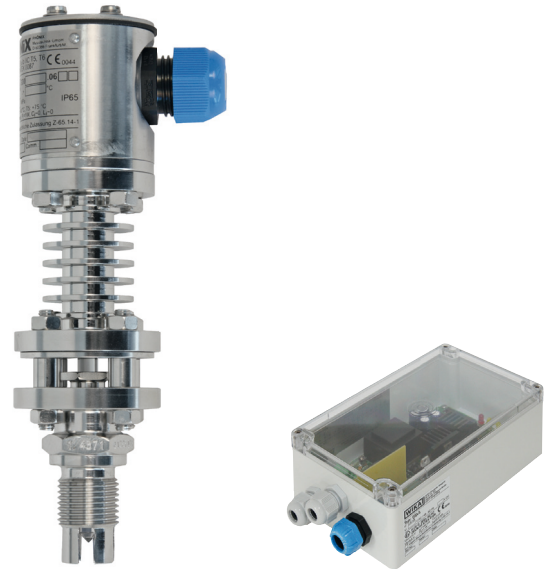
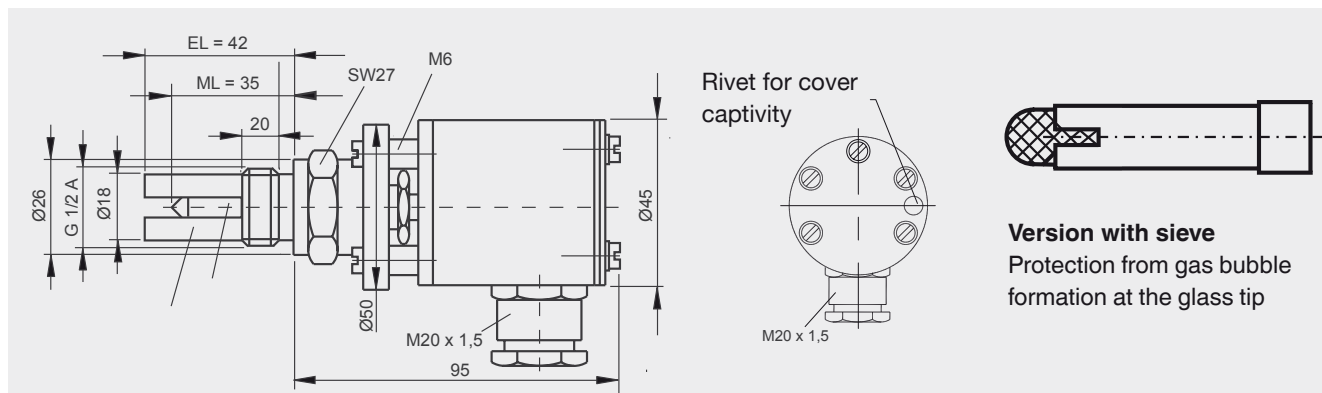

Fig. left: Optoelectronic level switch, model OLS-H
Fig. right: Switching amplifier, model OSA-S, aluminum add-on case

Model overview

Model	Description	Max. pressure in bar	Medium temperature in °C	Ambient temperature in °C	Item No.
OLS-H	Optoelectronic level switch, high-pressure version	176	0 ... +250	-65 ... +95	120552
OLS-H-HT	Optoelectronic level switch, high-pressure version for high temperature	176	0 ... +350	-65 ... +95	120551
OSA-S	Switching amplifier 230 VAC	-	-	-40 ... +40	120553
OSA-S	Switching amplifier 24 VDC	-	-	-40 ... +40	120554

Optoelectronic level switch, model OLS-H



Specifications	
Switch point ML	35 mm
Insertion length EL	42 mm, with sieve 52 mm
Medium temperature	0 ... +250 °C
Ambient temperature	-65 ... +95 °C
Pressure range	0 ... 176 bar
Glass protection	Guard finger
Process connection	G 1/2"
Material	Stainless steel 1.4571
Light guide	Sapphire
Mounting position	As required
Measuring accuracy	±0.5 mm
Repeat accuracy	±0.1 mm
Light source	IR light 930 nm
Ambient light	Max. 100 Lux
Cable gland	M20 x 1.5 / Han 7 D connector
Terminal connection	3 x 2.5 mm ²
Ingress protection	IP 65
With additional glass protection	sieve

Option for high-temperature

Optoelectronic level switch, model OLS-H-HT

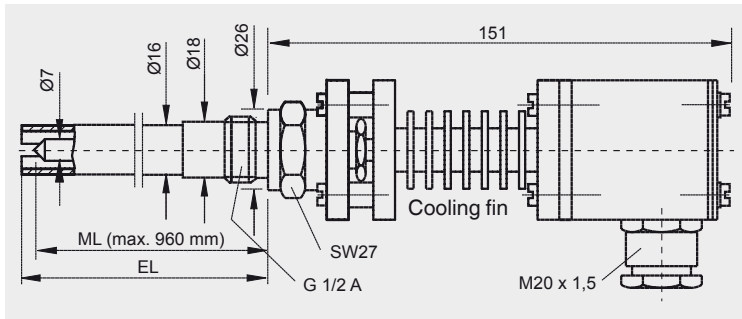

Specification: with cooling fin

Temperature range	0 ... +350 °C
Ambient temperature	-65 ... +95 °C

Electrical connection diagram

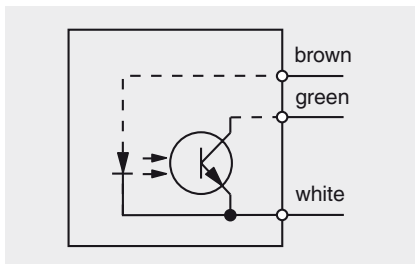

Switching amplifier model OSA-S

Version in aluminum add-on case

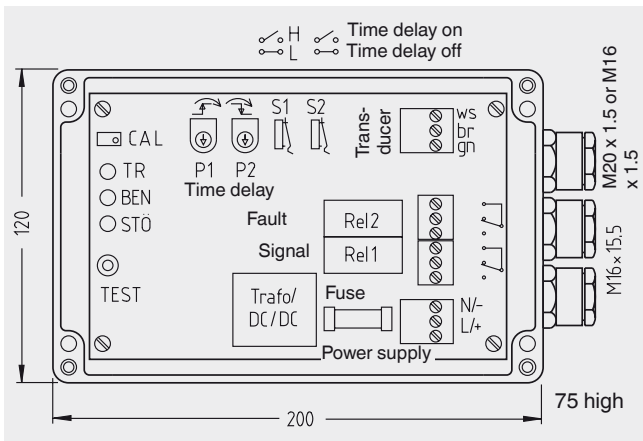

Specifications

Ambient temperature	-40 ... +40 °C
Power supply	AC 230 VAC / 24 VDC
Power consumption	2.8 VA, 3 W
Outputs	Signal relay, change-over contact, 250 V, 3 A, 100 VA Failure relay, change-over contact, 250 V, 3 A, 100 VA
Cable gland	M16 x 1.5
Max. connection cross-section	2.5 mm ²
Max. cable length	175 ... 600 m (with 0.5 ... 1.5 mm ²)
Ingress protection	IP 65

Electrical connection diagram

