

Strain transducer, standard to 1,000 $\mu\epsilon$ Model F9846



Part of your business

WIKA data sheet FO 54.17

EAC

Applications

- Silo weighing
- Injection moulding machinery
- Pressing, punching, embossing machinery
- Steel construction
- Vessel supports and tanks

Special features

- Strain of 0 ... 200 $\mu\epsilon$ to max. 0 ... 1,000 $\mu\epsilon$
- Can be retrofitted, easy installation with M6-screws
- Total error < 1 % F_{nom}
- Electrical connection as cable, with plug-in radio module, display or junction box.

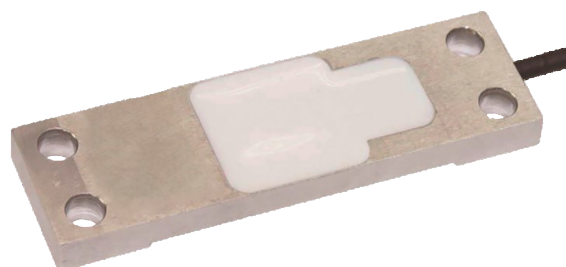

Strain transducer, model F9846

Description

Strain transducers have been designed for applications in which there is a need to measure the deformation due to external forces acting on existing components. The transducer is simply screwed to the component. After the adjustment, the unit has the features of a force transducer.

The strain transducer is fastened with four screws to an area of the structure where the relevant strain occurs. Combined strain transducers can be connected directly to a junction box that contains an amplifier for system control.

Specifications per VDI/VDE/DKD 2638

Model F9846	
Strain	0 ... ±200 µε, 0 ... ±500 µε, 0 ... ±1,000 µε
Total error ¹⁾	≤ ±1 % F _{nom}
Relative linearity error of the zero signal d _{S, 0}	≤ ±2 % F _{nom}
Temperature effect on zero signal TK ₀	0.5 %/10 K
Temperature effect on characteristic value TK _C	0.5 %/10 K
Force limit F _L	120 %
Breaking force F _B	150 %
Rated temperature range B _{T, nom}	-10 ... +40 °C [14 ... 104 °F]
Operating temperature range B _{T, G}	-20 ... +80 °C [-4 ... 176 °F]
Output signal (rated characteristic value) C _{nom}	1.0 ±0.15 mV/V
Input resistance Re	1,000 ±10 Ω
Output resistance Ra	1,000 ±3 Ω
Insulation resistance Ris	≥2,000 MΩ / DC 50 V
Electrical connection	
Standard	Cable outlet, free stranded wires
Option	Circular connector M12 x 1, 4-pin
Cable length	0.6 m [23.6 in]
Mounting	
	4 x Ø 6.6 mm bores [4 x Ø 0.26 in]
	2 x Ø 6.6 mm bores [2 x Ø 0.26 in]
Supply voltage	DC 5 ... 10 V (max. 15 V)
Ingress protection (per IEC/EN 60529)	IP65
Weight	0.1 kg [2.2 lbs]

1) Including non-linearity, hysteresis and repeatability



Working principle

If a mechanical construction is subjected to a load, its shape changed up to a certain extent. By fixing an appropriate area of the strain transducer, it experiences the same deformations as the component. Conversely, the determined strain allow conclusions on the state of tension. In this way, the force acting on the component can be measured.

After mounting the strain transducer, the assembled unit still has to be calibrated. Zero point and span are set individually for this.

Special requirements such as adjustment of the temperature coefficient (TC) of the output signal to the applied component or setting of the limit frequency for factory programming is possible with model F9302.

Approvals

Logo	Description	Region
	EU declaration of conformity	European Union
	EMC directive	
	RoHS directive	
	EAC (option)	Eurasian Economic Community
	EMC directive	

Dimensions in mm [in]

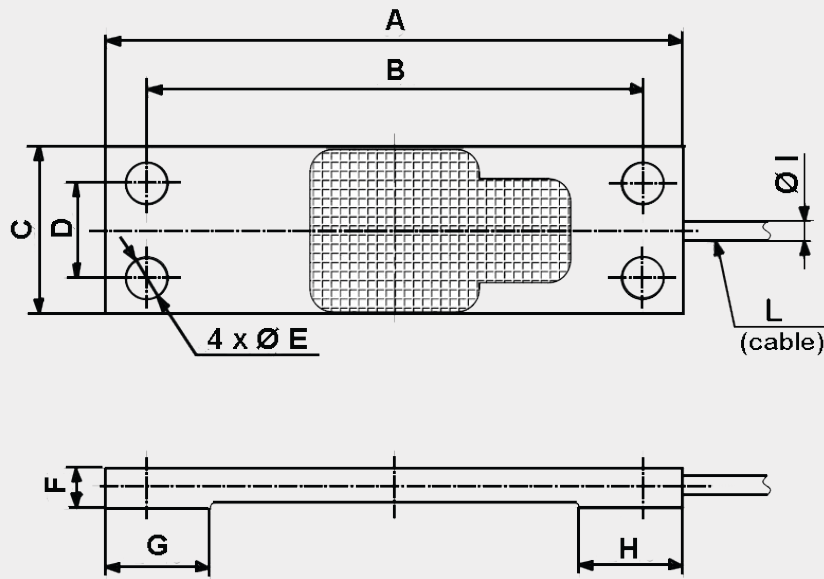

Dimensions in mm [in]

A	B	C	D	Ø E	F	G	H	Ø I	L
89 [3.5]	76.2 [3]	25.4 [1]	14.3 [0.56]	6.6 [0.26]	6.4 [0.25]	16 [0.63]	16 [0.63]	3 [0.12]	600 [23.62]

Pin assignment

Electrical connection	
Supply (UB+)	Red
Supply (UB-)	Black
Signal (+)	Green
Signal (-)	White
Shield ⊕	Shield

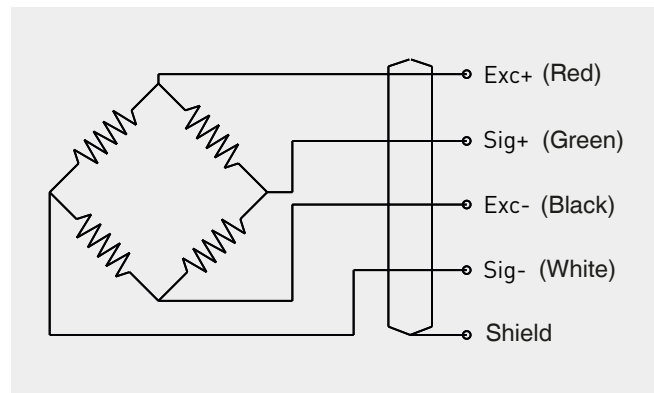

Accessories and spare parts

Model	Description	Bestellnummer
B1940	Analogue cable amplifier	83805811
B6578	Junction box for load cells	64418893

© 05/2022 WIKA Alexander Wiegand SE & Co. KG, all rights reserved.
The specifications given in this document represent the state of engineering at the time of publishing.
We reserve the right to make modifications to the specifications and materials.