



# PV-ISOTEST

## User manual

**TABLE OF CONTENTS**

1. PRECAUTIONS AND SAFETY MEASURES .....	3
1.1. Preliminary instructions .....	3
1.2. During use .....	4
1.3. After use .....	4
1.4. Definition of measurement (overvoltage) category .....	4
2. GENERAL DESCRIPTION .....	5
2.1. Foreword .....	5
2.2. Instrument functions .....	5
3. PREPARATION FOR USE .....	6
3.1. Initial checks .....	6
3.2. Instrument power supply .....	6
3.3. Storage .....	6
4. NOMENCLATURE .....	7
4.1. Description of the instrument .....	7
4.2. Keyboard description .....	8
4.3. Display description .....	8
4.4. Initial screen .....	8
5. GENERAL MENU .....	9
5.1. SET – instrument settings .....	9
5.1.1. Language .....	9
5.1.2. Date and time .....	9
5.1.3. General .....	10
5.1.4. Info .....	10
6. OPERATING INSTRUCTIONS .....	11
6.1. RPE – Continuity measurement on modules/strings/PV fields .....	11
6.1.1. Calibration of measuring cables .....	11
6.1.2. Carrying out continuity measurements in Standard (STD) mode .....	13
6.1.3. Carrying out continuity measurements in Timer (TMR) mode .....	15
6.1.4. Anomalous situations .....	17
6.2. M $\Omega$ – Measurement of insulation on PV modules/strings/fields .....	18
6.2.1. Measuring insulation – DUAL mode .....	18
6.2.2. Measuring insulation – TMR mode .....	20
6.2.3. Anomalous situations .....	23
6.3. GFL – Searching for conditions of low insulation on PV strings .....	25
6.4. DMM – Multimeter function .....	29
7. STORING RESULTS .....	30
7.1. Saving measures .....	30
7.2. Recall of data to display and memory deletion .....	31
8. CONNECTING THE INSTRUMENT TO THE PC .....	32
9. MAINTENANCE .....	33
9.1. General information .....	33
9.2. Battery replacement .....	33
9.3. Cleaning the instrument .....	33
9.4. End of life .....	33
10. TECHNICAL SPECIFICATIONS .....	34
10.1. Technical characteristics .....	34
10.2. General characteristics .....	35
10.2.1. Reference guidelines .....	35
10.2.2. Display and memory .....	35
10.2.3. Power supply .....	35
10.2.4. Mechanical characteristics .....	35
10.3. Environmental conditions for use .....	35
10.4. Accessories .....	35
11. APPENDIX – THEORETICAL OUTLINE .....	36
11.1. Measurement of polarization index (PI) .....	36

---

11.2. Dielectric Absorption Ratio (DAR).....	36
12. ASSISTANCE.....	37
12.1. Warranty conditions.....	37
12.2. Assistance.....	37

## 1. PRECAUTIONS AND SAFETY MEASURES

The instrument has been designed in compliance with directive IEC/EN61010-1 relevant to electronic measuring instruments. Before and while carrying out measurements, observe the following indications and read all notes preceded by the symbol  with the utmost attention.

- Do not carry out any voltage or current measurement in humid environments
- Do not carry out any measurements in case gas, explosive materials or flammables are present, or in dusty environments
- Avoid any contact with the circuit being measured if no measurements are being carried out.
- Avoid contact with exposed metal parts, with unused measuring probes, etc.
- Do not carry out any measurement in case you find anomalies in the instrument such as deformation, breaks, absence of display on the screen, etc.
- Pay special attention when measuring voltages higher than 25V in special environments and 50V in normal environments, since a risk of electrical shock exists.

In this manual, and on the instrument, the following symbols are used:



Warning: observe the instructions given in this manual; improper use could damage the instrument or its components.



High voltage danger: electrical shock hazard.



Double insulation



DC voltage



AC voltage



Connection to earth

### 1.1. PRELIMINARY INSTRUCTIONS



- This instrument has been designed for use in the environmental conditions specified in section § 10.3. Do not use in different environmental conditions.
- The instrument may be used for measuring **VOLTAGE** in CAT III 1500VDC and CAT III 1000VAC with a maximum voltage of 1500VDC and 1000VAC between inputs. Do not use on circuits exceeding the limit values specified in § 10.1
- We recommend following the normal safety rules devised to protect the user against dangerous currents and the instrument against incorrect use.
- Only the accessories provided together with the instrument will guarantee safety standards. They must be in good conditions and replaced with identical models, when necessary.
- Make sure that batteries are correctly installed.
- Before connecting the measuring cables to the circuit being measured, check that the desired function has been selected.

## 1.2. DURING USE

Please carefully read the following recommendations and instructions:



### CAUTION

- Failure to comply with the caution notes and/or instructions may damage the instrument and/or its components, or be a source of danger for the operator.
- The symbol “” indicates a full charge level of the internal batteries. When battery charge decreases to a minimum level, the symbol “” appears on the display. In this case, stop testing and replace the batteries according to the indications given in § 9.2. 9.2
- **The instrument is capable of keeping data stored even without batteries.**

## 1.3. AFTER USE

When measurements are complete, switch off the instrument by pressing and holding the **ON/OFF** key for some seconds. If the instrument is not to be used for a long time, remove the batteries and follow the instructions given in § 3.3.

## 1.4. DEFINITION OF MEASUREMENT (OVERVOLTAGE) CATEGORY

Standard “IEC/EN61010-1: Safety requirements for electrical equipment for measurement, control and laboratory use, Part 1: General requirements”, defines what measurement category, commonly called overvoltage category, is. § 6.7.4: Measured circuits, reads:

Circuits are divided into the following measurement categories:

- **Measurement category IV** is for measurements performed at the source of the low-voltage installation.  
*Examples are electricity meters and measurements on primary overcurrent protection devices and ripple control units.*
- **Measurement category III** is for measurements performed on installations inside buildings.  
*Examples are measurements on distribution boards, circuit breakers, wiring, including cables, bus-bars, junction boxes, switches, socket-outlets in the fixed installation, and equipment for industrial use and some other equipment, for example, stationary motors with permanent connection to fixed installation.*
- **Measurement category II** is for measurements performed on circuits directly connected to the low-voltage installation.  
*Examples are measurements on household appliances, portable tools and similar equipment.*
- **Measurement category I** is for measurements performed on circuits not directly connected to MAINS.  
*Examples are measurements on circuits not derived from MAINS, and specially protected (internal) MAINS-derived circuits. In the latter case, transient stresses are variable; for that reason, the standard requires that the transient withstand capability of the equipment is made known to the user.*

## 2. GENERAL DESCRIPTION

### 2.1. FOREWORD

This instrument has been designed to carry out safety tests on photovoltaic (PV) modules/strings in order to verify the parameters declared by the manufacturer. In addition, this instrument measures insulation/continuity on PV modules/strings/fields.

### 2.2. INSTRUMENT FUNCTIONS

The instrument has the following features:

#### **Continuity test of protective conductors (RPE)**

- Test with test current > 200mA in compliance with standards IEC/EN62446-1, IEC/EN61557-4.
- Manual calibration of measuring cables.

#### **Measurement of insulation resistance on PV modules/strings (M $\Omega$ )**

- Test voltages of 250V, 500V, 1000V, 1500VDC in compliance with standards IEC/EN62446-1, IEC/EN61557-2
- 2 available measuring modes
  - DUAL → Measurement in a sequence of the insulation between the string's positive pole (+) and PE and between the string's negative pole and PE.
  - TMR → single timed measurement between the string's negative pole and PE.

#### **GFL (Ground Fault Locator) function to search for positions with a low insulation among the modules of a PV string (see § 6.3).**

The instrument is provided with backlit display, internal contrast adjustment and a **HELP** key able to give a valid help to the operator while connecting the instrument to the installation. An Auto Power OFF function, which can also be deactivated, is available after approx. 5 minutes idleness.



### 3. PREPARATION FOR USE

#### 3.1. INITIAL CHECKS

Before shipping, the instrument has been checked from an electric as well as mechanical point of view. All possible precautions have been taken so that the instrument is delivered undamaged. However, we recommend checking it to detect any damage possibly suffered during transport. In case anomalies are found, immediately contact the dealer. We also recommend checking that the packaging contains all components indicated in § 10.4. In case of discrepancy, please contact the Dealer. In case the instrument should be returned, please follow the instructions given in § . 12

#### 3.2. INSTRUMENT POWER SUPPLY

The instrument is battery supplied. For battery type and life, see § **Errore. L'origine riferimento non è stata trovata.**

The symbol “” indicates a full charge level of the internal batteries. When battery charge decreases to a minimum level, the symbol “” appears on the display. In this case, stop testing and replace the batteries according to the indications given in § 9.2.

**The instrument is capable of keeping data stored even without batteries.**

The instrument is provided with advanced algorithms to maximize the batteries life. **Long pressing the key HELP** activates the display's backlight adjustment. A frequent use of backlighting reduces the batteries life.

#### 3.3. STORAGE

In order to guarantee precise measurement, after a long storage time under extreme environmental conditions, wait for the instrument to come back to normal condition (see § 10.3).

## 4. NOMENCLATURE

### 4.1. DESCRIPTION OF THE INSTRUMENT

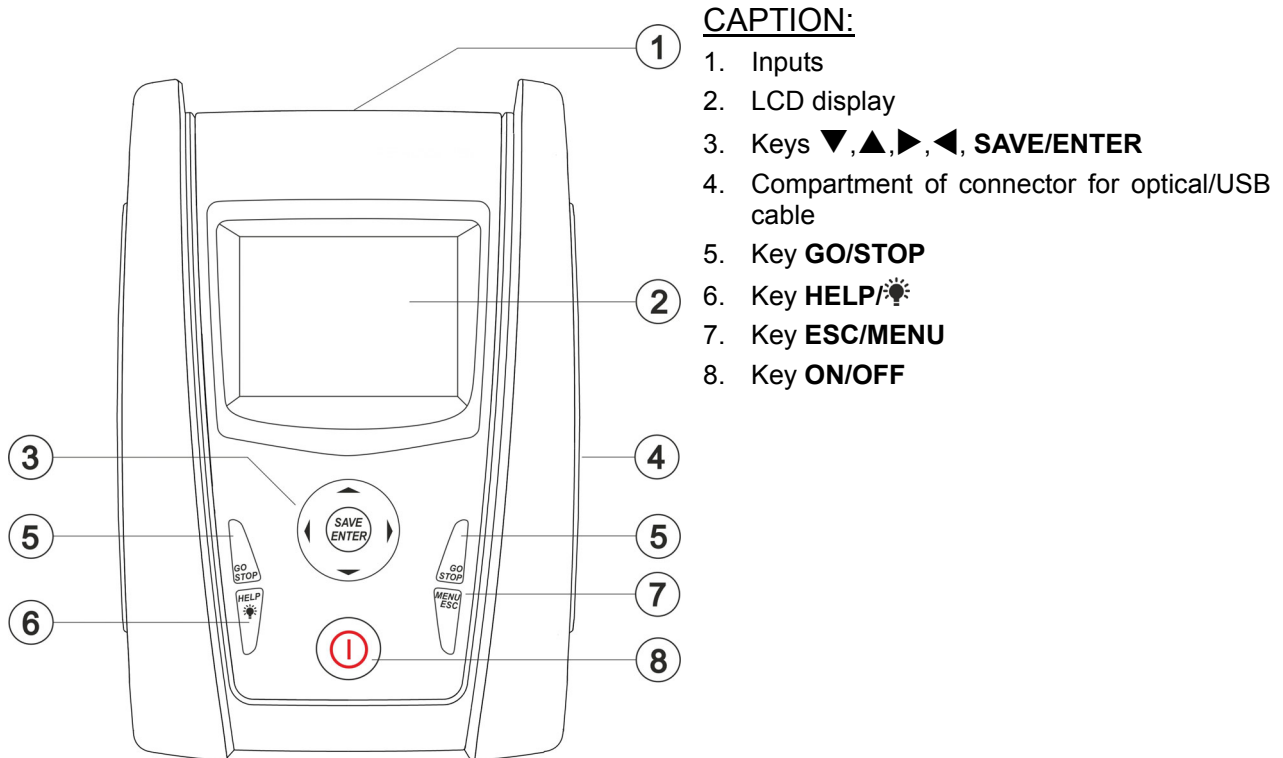

Fig. 1: Description of the front part of the instrument

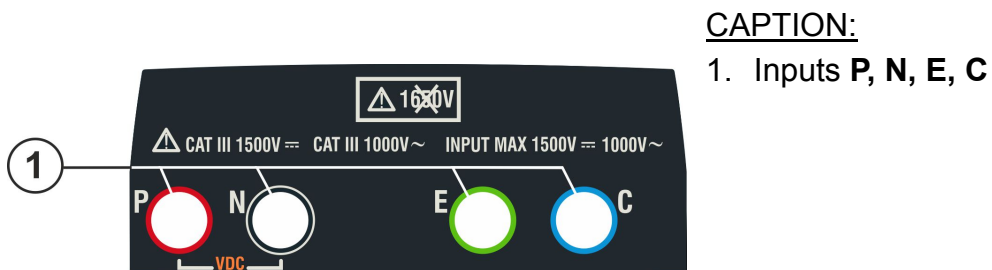

Fig. 2: Description of the upper part of the instrument

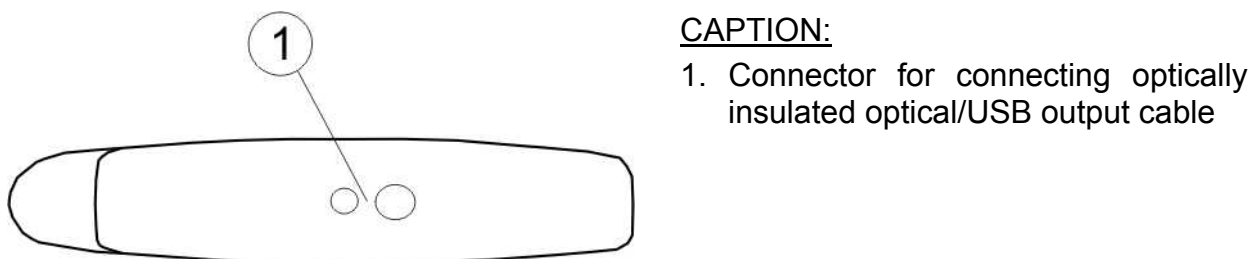

Fig. 3: Description of the instrument's side



## 4.2. KEYBOARD DESCRIPTION

The keyboard includes the following keys:



**ON/OFF** key to switch on/off the instrument



**ESC** key to exit the selected menu without confirming

**MENU** key to go back to the instrument's general menu at any time



Keys ◀ ▶ ▲ ▼ to move the cursor within the various screens in order to select programming parameters

**SAVE/ENTER** key to save internal parameters and the results of measurements (SAVE) and to select the desired functions from the menu (ENTER)



**GO** key to start measuring

**STOP** key to stop measuring



**HELP** key to access the help on line and display, for each selected function, possible connections between the instrument and the system

Key  (**long pressing**) to adjust the display's backlight

## 4.3. DISPLAY DESCRIPTION

The display is a graphic module with a resolution of 128 x 128 dots. The displays first line indicates the systems date/time and contains the battery charge indicator. At the bottom of the display, the active mode is shown.

## 4.4. INITIAL SCREEN

When switching on the instrument, the initial screen appears for a few seconds. It shows:

- The instrument model (PV-ISOTEST)
- The manufacturer's name
- The serial number (SN:) of the instrument
- The firmware version (FW:) in the instrument's memory
- The date of the last instrument calibration (Calibration date:)

**PV-ISOTEST**

**HT ITALIA**

SN: 20345678

HW: 1.00

FW: 1.02

Calibration date:

07/09/2020

After a few seconds, the instrument switches to the last function selected.

## 5. GENERAL MENU

Pressing the **ESC/MENU** key in any condition of the instrument displays the general menu screen, in which the instrument may be set, the saved measures can be displayed and the desired measuring function can be selected.

Use the cursor to select one of the options and confirm with **ENTER** to access the desired function.

MENU	14/09 -17:34	
DMM	: Voltage	
MΩ	: Insulation:	
GFL	Find Insul. fault	
RPE	: Continuity	
SET	: Settings	
MEM	: Data saved	
PC	: Data transfer	

### 5.1. SET – INSTRUMENT SETTINGS

Position the cursor onto **SET** by using the arrow keys (**▲**, **▼**) and confirm with **ENTER**. The display shows the screen which lists the different settings of the instrument.

Settings will be maintained also after switching off the instrument.

SET	14/09 -17:34	
Language		
Date and time		
General settings		
Information		

#### 5.1.1. Language

Move the cursor to **Language** by using the arrow keys (**▲**, **▼**) and confirm with **ENTER**. The instrument shows the screen which allows setting the system language.

Select the desired option by using the arrow keys (**▲**, **▼**). Press the **ENTER** key to confirm or the **ESC** key to go back to the previous screen.

SET	14/09 – 17:34	
English		
Italian		
Español		
Deutsch		
Français		
Portuguese		

#### 5.1.2. Date and time

1. Position the cursor onto “**Data Time**” by using the arrow keys (**▲**, **▼**) and confirm with **ENTER**.
2. The display shows the screen which allows setting the system’s date/time both in the **European (EU)** and in the **USA (US)** format.
3. Set the desired measuring units by means of the arrow keys (**◀**, **▶**).
4. Press the **SAVE** key to save the settings made; the message “Data saved” will be displayed for a few seconds. Press the **ESC/MENU** key to exit without saving and go back to the previous screen.

SET	14/09 – 17:34	
Format	:< EU >	
Year	:< 20 >	
Month	:< 09 >	
Day	:< 14 >	
Hour	:< 17 >	
Minute	:< 34 >	

### 5.1.3. General

Move the cursor to **General** by using the arrow keys (▲,▼) and confirm with **ENTER**. The instrument shows the screen which allows activating/deactivating the the Auto Power Off function and the key tone.

Select the desired option by using the arrow keys (▲,▼). Press the **ENTER** key to confirm or the **ESC** key to go back to the previous screen.

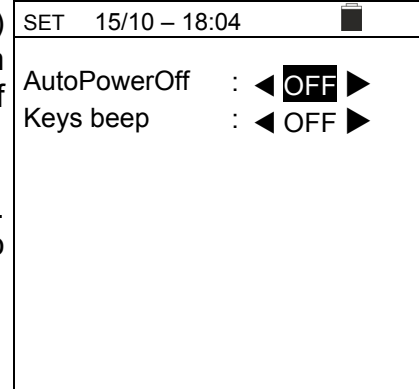

### 5.1.4. Info

Move the cursor to **Info** by using the arrow keys (▲,▼) and confirm with **ENTER**.

The instrument shows the initial screen as indicated in the screen to the side.

Press the **ESC** key to go back to the main menu.



## 6. OPERATING INSTRUCTIONS

### 6.1. RPE – CONTINUITY MEASUREMENT ON MODULES/STRINGS/PV FIELDS

The purpose of this measurement is performing a continuity test of the protective and equipotential conductors (e.g.: from rod to earth and connected foreign earth) and earth rods of SPDs on PV installations. The test must be carried out using a test current  $> 200\text{mA}$  according to the prescriptions of IEC/EN62446-1 and IEC/EN61557-4 guidelines.

#### 6.1.1. Calibration of measuring cables

1. Position the cursor onto **RPE** by using the arrow keys ( $\blacktriangle$ ,  $\blacktriangledown$ ) and confirm with **ENTER**. The display shows the following screen:

RPE 15/10 – 18:04			
R	- - -	$\Omega$	
I <sub>test</sub>	- - -	mA	
STD	2.00 $\Omega$	- - - $\Omega$	
MODE	Lim.		$>\phi<$

2. Use the arrow keys  $\blacktriangleleft$  or  $\blacktriangleright$  and select the position “ $>\phi<$ ”. The display shows the screen to the side.

RPE 15/10 – 18:04			
R	- - -	$\Omega$	
I <sub>test</sub>	- - -	mA	
STD	2.00 $\Omega$	- - - $\Omega$	
MODE	Lim.		$>\phi<$

3. Connect the measuring cables to each other as shown in Fig. 4.

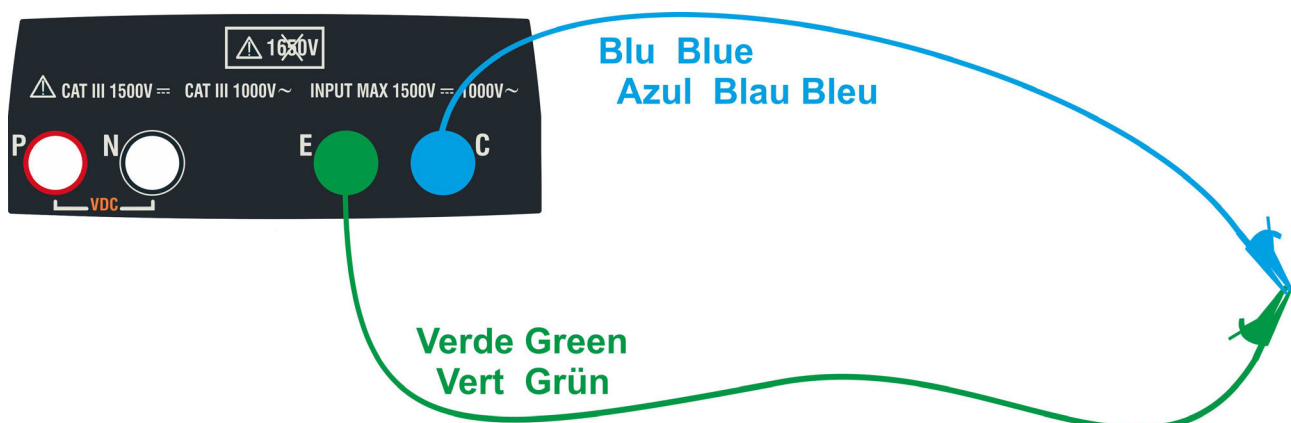



Fig. 4: Compensation of the measuring cables resistance

4. Use the arrow keys ◀ or ▶ and select the position “>ϕ<”.  
The display shows the screen to the side.

RPE		15/10 – 18:04		
R	- - -	Ω		
I <sub>test</sub>	- - -	mA		
STD	2.00Ω	- - - Ω		
MODE	Lim.		>ϕ<	

5. Press the **GO/STOP** key to start calibration. Messages “Measuring...” followed by “Verification” and “Zeroing” are shown in a sequence on the display.

RPE		15/10 – 18:04		
R	- - -	Ω		
I <sub>test</sub>	- - -	mA		
Measuring...				
STD	2.00Ω	- - - Ω		
MODE	Lim.		>ϕ<	

6. At the end of the compensation procedure, in case the measured resistance value is  $\leq 5\Omega$ , the instrument emits a double tone to signal the positive result of the test and displays the value of the compensated resistance of the cables, which will be subtracted from all the subsequent continuity measurements, at the bottom on the right side of the display.

RPE		15/10 – 18:04		
R	- - -	Ω		
I <sub>test</sub>	- - -	mA		
STD	2.00Ω	0.06 Ω		
MODE	Lim.		>ϕ<	

### 6.1.2. Carrying out continuity measurements in Standard (STD) mode

1. Position the cursor onto **RPE** by using the arrow keys (**▲**, **▼**) and confirm with **ENTER**. The display shows the following screen. The symbol “STD” is shown on the display.

RPE	15/10 – 18:04		
R	- - -	Ω	
Itest	- - -	mA	
STD	2.00Ω	- - - Ω	
MODE	Lim.		>φ<

2. Use the arrow keys **◀** or **▶** and select the position “**Lim.**”. The display shows the screen to the side.
3. Use the arrow keys (**▲**, **▼**) to set the limit reference threshold for continuity measurement, which can be selected in a range between **0.01Ω ÷ 9.99Ω** in steps of **0.01Ω** (please remember that guidelines does not establish a limit value or resistance and typical values are approx. 1Ω or 2Ω).

RPE	15/10 – 18:04		
R	- - -	Ω	
Itest	- - -	mA	
STD	2.00Ω	- - - Ω	
MODE	Lim.		>φ<

4. Carry out the initial calibration of the measuring cables (see § 6.1.1).
5. Connect the instrument to the PV module/string being tested and to the main earth node of the system as shown in Fig. 5.

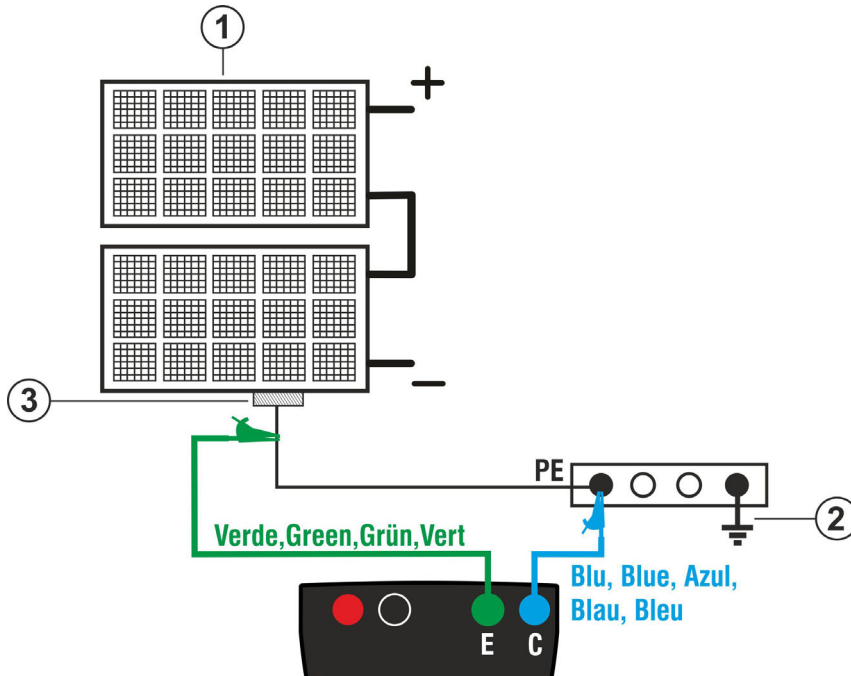

#### CAPTION:

E: Green cable  
C: Blue cable

1. PV module/string
2. Main system earthing
3. Earthed metal structure in the system

Fig. 5: Connection of meter for continuity measurement on structures of the PV installation



#### CAUTION

Upon pressing the **GO/STOP** key, different error messages can be displayed by the instrument (see § 6.1.4) and, therefore, the test cannot be started. Check and eliminate, if possible, the problem causing the error message before going on with the test.

6. Press the **GO/STOP** key to start the test. In case no error conditions occur, the instrument displays the message “**Measuring...**” as shown in the screen to the side.

RPE	15/10 – 18:04		
R	- - -	$\Omega$	
I <sub>test</sub>	- - -	mA	
<b>Measuring...</b>			
STD	2.00 $\Omega$	0.06 $\Omega$	
MODE	Lim.		> $\phi$ <

7. At the end of measurement, the instrument provides the value of resistance of the object being tested. If the result is lower than the set maximum limit value, the instrument shows the message “**OK**” (value lower or equal to the set limit threshold), otherwise it displays the message “**NO OK**” (value higher than the set limit threshold) as shown in the screen to the side.

8. Press the **SAVE** key to store the test result in the instrument’s memory (see § 7.1) or the **ESC/MENU** key to exit the screen without saving and go back to the main measuring screen.

RPE	15/10 – 18:04		
R	0.23	$\Omega$	
I <sub>test</sub>	210	mA	
<b>OK</b>			
STD	2.00 $\Omega$	0.06 $\Omega$	
MODE	Lim.		> $\phi$ <

### 6.1.3. Carrying out continuity measurements in Timer (TMR) mode

- Position the cursor onto **RPE** by using the arrow keys (**▲**, **▼**) and confirm with **ENTER**. The display shows the following screen.
- Use the arrow keys (**▲**, **▼**) to select the Timer mode. The symbol “TMR” is shown on the display.

RPE	15/10 – 18:04			
R	- - -	$\Omega$		
I <sub>test</sub>	- - -	mA		
T	- - -	s		
TMR	2.00 $\Omega$	12s	- - - $\Omega$	
MODE	Lim.	Time	> $\phi$ <	

- Use the arrow keys **◀** or **▶** and select the position “**Lim.**”. The display shows the screen to the side.
- Use the arrow keys (**▲**, **▼**) to set the limit reference threshold for continuity measurement, which can be selected in a range between **0.01 $\Omega$  ÷ 9.99 $\Omega$**  in steps of 0.01 $\Omega$  (please remember that guidelines does not establish a limit value or resistance and typical values are approx. 1 $\Omega$  or 2 $\Omega$ ).

RPE	15/10 – 6:04 PM			
R	- - -	$\Omega$		
I <sub>test</sub>	- - -	mA		
T	- - -	s		
TMR	2.00 $\Omega$	12s	- - - $\Omega$	
MODE	Lim.	Time	> $\phi$ <	

- Use the arrow keys **◀** or **▶** and select the position “**Time**”. The display shows the screen to the side.
- Use the arrow keys (**▲**, **▼**) to set the **duration of continuity measurement (Timer)**, which can be selected in a range between **3s ÷ 99s in steps of 3s**.

RPE	15/10 – 18:04			
R	- - -	$\Omega$		
I <sub>test</sub>	- - -	mA		
T	- - -	s		
TMR	2.00 $\Omega$	12s	- - - $\Omega$	
MODE	Lim.	Time	> $\phi$ <	

- Carry out the initial calibration of the measuring cables (see § 6.1.1).
- Connect the instrument to the PV module/string being tested and to the main earth node of the system as shown in Fig. 5.



#### CAUTION

Upon pressing the **GO/STOP** key, different error messages can be displayed by the instrument (see § 6.1.4) and, therefore, the test cannot be started. Check and eliminate, if possible, the problem causing the error message before going on with the test.



9. Press the **GO/STOP** key to start the test. In case no error conditions occur, the instrument starts a series of continuous measurements for the entire duration of the set Timer, **emitting a short sound every 3s**, and showing alternatively the messages “**Measuring...**” and “**Please wait...**” as shown in the screen to the side. In this way, the operator can move from one point to another of the place in which measurement is being carried out.

RPE	15/10 – 18:04		
R	0.23	$\Omega$	
I <sub>test</sub>	209	mA	
T	11	S	
Please wait...			
STD	2.00 $\Omega$	12s	0.06 $\Omega$
MODE	Lim.	Time	> $\phi$ <

10. At the end of measurement, the instrument provides the maximum value among all those of the partial measurements carried out. If the result is lower than the set maximum limit value, the instrument shows the message “**OK**” (value lower or equal to the set limit threshold), otherwise it displays the message “**NO OK**” (value higher than the set limit threshold) as shown in the screen to the side.

RPE	15/10 – 6:04 PM		
R	0.54	$\Omega$	
I <sub>test</sub>	209	mA	
T	0	S	
OK			
STD	2.00 $\Omega$	12s	0.06 $\Omega$
MODE	Lim.	Time	> $\phi$ <

11. Press the **SAVE** key to store the test result in the instrument’s memory (see § 7.1) or the **ESC/MENU** key to exit the screen without saving and go back to the main measuring screen.

### 6.1.4. Anomalous situations

1. To zero the value of compensated resistance, carry out a new compensation procedure with a resistance higher than  $5\Omega$  as, for example, with open leads. The message “Zero Reset” appears on the display.

RPE	15/10 – 18:04		
R	- - -	$\Omega$	
I <sub>test</sub>	- - -	mA	
<b>Zero Reset</b>			
STD	2.00 $\Omega$	- - - $\Omega$	
MODE	Lim.		> $\phi$ <

2. In case the instrument detects a voltage **higher than 3V** at its terminals E and C, it does not carry out the test, gives out a long sound and displays the message “V.Input > 3V”.

RPE	15/10 – 18:04		
R	- - -	$\Omega$	
I <sub>test</sub>	- - -	mA	
<b>V.Input &gt; 3V</b>			
STD	2.00 $\Omega$	- - - $\Omega$	
MODE	Lim.		> $\phi$ <

3. In case the instrument detects that the calibrated resistance is higher than the measured resistance, the instrument gives out a long sound and displays the message: “Zeroing NOT OK”

RPE	15/10 – 18:04		
R	0.03	$\Omega$	
I <sub>test</sub>	212	mA	
<b>Zeroing NOT OK</b>			
STD	2.00 $\Omega$	0.220 $\Omega$	
MODE	Lim.		> $\phi$ <

4. In case the instrument detects a resistance higher than  $5\Omega$  at its terminals, it gives out a long sound, zeroes the compensated value and displays the message “Zero Reset”.

RPE	15/10 – 18:04		
R	>4.99	$\Omega$	
I <sub>test</sub>	49	mA	
<b>Zero Reset</b>			
STD	2.00 $\Omega$	- - - $\Omega$	
MODE	Lim.		> $\phi$ <

5. If the instrument detects a calibrated resistance higher than measured resistance (e.g. by using test cables different from the supplied ones) at its terminals, it gives out a long sound and displays a screen like the one to the side. Perform a calibration reset with open terminals and start a new calibration.

RPE	15/10 – 18:04		
R	- - -	$\Omega$	
I <sub>test</sub>	- - -	mA	
<b>Rcal &gt; Rmis</b>			
STD	2.00 $\Omega$	- - - $\Omega$	
MODE	Lim.		> $\phi$ <

## 6.2. MΩ – MEASUREMENT OF INSULATION ON PV MODULES/STRINGS/FIELDS

The purpose of this function is measuring the insulation resistance of the active conductors of PV modules, strings and fields according to the prescriptions of IEC/EN62446-1 and IECEN61557-2 guidelines, **with no need to use an external switch to short-circuit the positive and negative terminals.**



### CAUTION

- The insulation measurement can be performed on a single module, on a string or on a system consisting of several strings connected in parallel
- If the module/string/system has a pole connected to ground, this connection must be temporarily disconnected
- In compliance with IEC/EN62446-1, the test voltage  $V_{test}$  must be  $\geq$  rated voltage of the system
- The IEC/EN62446-1 guideline sets  $1M\Omega$  as the minimum insulation resistance limit value for systems with rated voltage higher than 120V
- Disconnect the string/system from the inverter and any dischargers
- It is advisable to carry out the insulation measurement upstream of any blocking diodes

In general, the instrument measures insulation in the following modes:

- **DUAL** mode → the instrument measures insulation in a sequence between the positive pole (+) and the PE reference and between the negative pole (-) and the PE reference of PV modules, strings and fields.
- **TMR** mode → the instrument measures continuously (with a max duration of 999s) between terminal “N” and PE reference, displaying the minimum resistance value obtained at the end of the selected time. In this way, the instrument also calculates the DAR (Dielectric Absorption Ratio) and PI (Polarization Index) parameters if the duration of the test is adequate for the calculation of the above parameters.

### 6.2.1. Measuring insulation – DUAL mode

1. Position the cursor onto **MΩ** by using the arrow keys (▲, ▼) and confirm with **ENTER**. The display shows the screen to the side. By using the arrow keys (▲, ▼) again, select the “**DUAL**” measuring mode, in position “**MODE**”.

MΩ	15/10 – 18:04		
	(+)	(-)	
V <sub>test</sub>	- - -	- - -	V
R <sub>ins</sub>	- - -	- - -	MΩ
	R <sub>p</sub>	- - -	MΩ
	V <sub>PN</sub>	V <sub>PE</sub>	V <sub>NE</sub>
	0V	0V	0V
DUAL	1500V	1.00MΩ	
MODE	V <sub>test.</sub>	Lim.	

2. Use the arrow keys ◀ or ▶ and select the position “**V<sub>test</sub>**” to set the test voltage.
3. Use the arrow keys (▲, ▼) to select one of the following test voltages (V<sub>nom</sub>): **250, 500, 1000, 1500VDC**. Please note that in compliance with IEC/EN62446-1 the test voltage  $V_{test}$  must be  $\geq$  rated voltage of the system

MΩ	15/10 – 18:04		
	(+)	(-)	
V <sub>test</sub>	- - -	- - -	V
R <sub>ins</sub>	- - -	- - -	MΩ
	R <sub>p</sub>	- - -	MΩ
	V <sub>PN</sub>	V <sub>PE</sub>	V <sub>NE</sub>
	0V	0V	0V
DUAL	1500V	1.00MΩ	
MODE	V <sub>test.</sub>	Lim.	

- Use the arrow keys ◀ or ▶ and select the position “Lim.”. The display shows the screen to the side.
- Use the arrow keys (▲,▼) to set the **minimum** limit threshold for insulation measurement, which can be selected among the values **0.05, 0.10, 0.23, 0.25, 0.50, 1.00, 50MΩ**. Please note that IEC/EN62446-1 guideline sets 1MΩ as the minimum insulation resistance limit value for systems with rated voltage higher than 120V

MΩ	15/10 – 18:04		■
	(+)	(-)	
Vtest	- - -	- - -	V
Rins	- - -	- - -	MΩ
	Rp	- - -	MΩ
	VPN	VPE	VNE
	0V	0V	0V
DUAL	1500V	1.00MΩ	
MODE	Vtest.	Lim.	

- Connect the instrument to the PV string to be tested as shown in Fig. 6. The test can also be performed on several strings in parallel with each other. Remember that any surge arresters connected to the string cables must be disconnected and that it is advisable to measure upstream of any blocking diodes

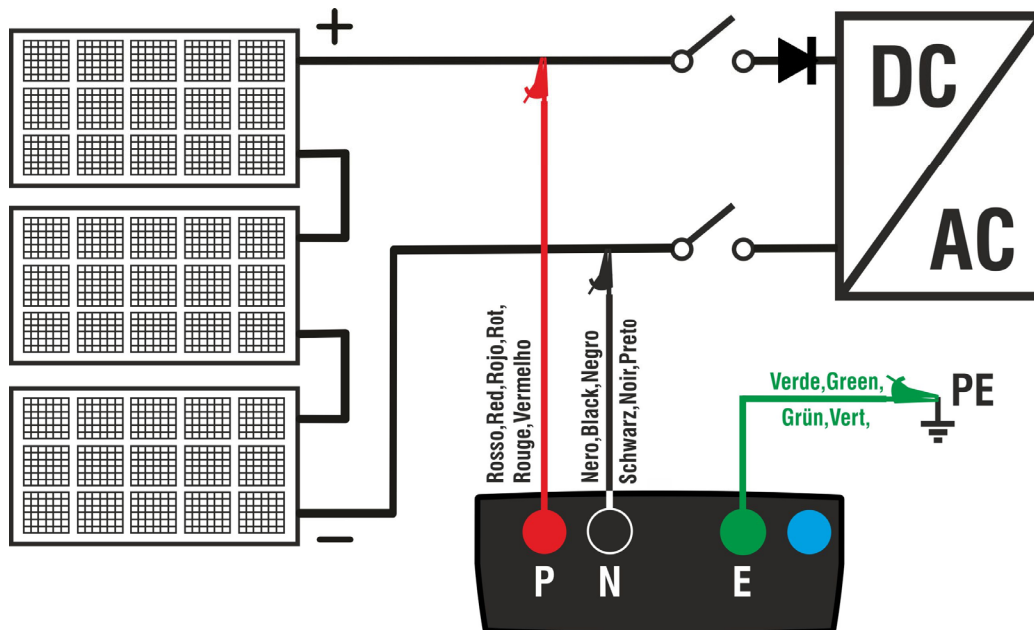

Fig. 6: Instrument connection for insulation measurement in DUAL mode

### CAUTION



Upon pressing the **GO/STOP** key, different error messages can be displayed by the instrument (see § 6.2.3) and, therefore, the test cannot be started. Check and eliminate, if possible, the problem causing the error message before going on with the test.

- Press and hold the GO/STOP key for 2s** in order to start the test. In case no error conditions occur, the instrument displays the message “Measuring...” as shown in the screen to the side. In field “Vtest”, the real test voltage generated by the instrument is shown. **The duration of the test can be depending on the presence or absence of parasitic capacities present**

MΩ	15/10 – 18:04		■
	(+)	(-)	
Vtest	- - -	- - -	V
Rins	- - -	- - -	MΩ
	Rp	- - -	MΩ
	VPN	VPE	VNE
	1480V	-750V	748V
<b>Measuring...</b>			
DUAL	1500V	1.00MΩ	
MODE	Vtest.	Lim.	

8. The instrument carries out the following measurements in a sequence:

- Insulation between positive pole (+) of the string and earth connection
- Insulation between negative pole (-) of the string and earth connection
- Calculation of the value of resistance **R<sub>p</sub>** given by the parallel of measurements (+) and (-)

If "**R<sub>p</sub> ≥ Lim**", the instrument shows the message "**OK**", to indicate the **positive** result of measurement.

Press the **SAVE** key to store the test result in the instrument's memory (see § 7.1) or the **ESC/MENU** key to exit the screen without saving and go back to the main measuring screen.

MΩ	15/10 – 18:04		
	(+)	(-)	
V <sub>test</sub>	1510	1515	V
R <sub>ins</sub>	>100	>100	MΩ
	R <sub>p</sub>	>100	MΩ
	VPN	VPE	VNE
	1480V	-750V	748V
<b>OK</b>			
DUAL	1500V	1.00MΩ	
MODE	V <sub>test</sub> .	Lim.	

### 6.2.2. Measuring insulation – TMR mode

1. Position the cursor onto **MΩ** by using the arrow keys (▲, ▼) and confirm with **ENTER**. The display shows the screen to the side. By using the arrow keys (▲, ▼) again, select the "**TMR**" measuring mode, in position "MODE".

MΩ	15/10 – 18:04		
V <sub>test</sub> (-)	- - -	- - -	V
R <sub>i</sub> (-)	- - -	- - -	MΩ
Time	- - -	- - -	s
DAR	- - -	PI	- - -
	VPN	VPE	VNE
	0V	0V	0V
TMR	1500V	1.00MΩ	3s
MODE	V <sub>test</sub> .	Lim.	Time

2. Use the arrow keys ◀ or ▶ and select the position "**V<sub>test</sub>**" to set the test voltage.

3. Use the arrow keys (▲, ▼) to select one of the following test voltages (V<sub>nom</sub>): **250, 500, 1000, 1500VDC**. Please note that in compliance with IEC/EN62446-1 the test voltage V<sub>test</sub> must be ≥ rated voltage of the system

MΩ	15/10 – 18:04		
V <sub>test</sub> (-)	- - -	- - -	V
R <sub>i</sub> (-)	- - -	- - -	MΩ
Time	- - -	- - -	s
DAR	- - -	PI	- - -
	VPN	VPE	VNE
	0V	0V	0V
TMR	1500V	1.00MΩ	3s
MODE	V <sub>test</sub> .	Lim.	Time

4. Use the arrow keys ◀ or ▶ and select the position "**Lim.**". The display shows the screen to the side.

5. Use the arrow keys (▲, ▼) to set the **minimum** limit threshold for insulation measurement, which can be selected among the values **0.05, 0.10, 0.23, 0.25, 0.50, 1.00, 50MΩ**. Please note that IEC/EN62446-1 guideline sets 1MΩ as the minimum insulation resistance limit value for systems with rated voltage higher than 120V

MΩ	15/10 – 18:04		
V <sub>test</sub> (-)	- - -	- - -	V
R <sub>i</sub> (-)	- - -	- - -	MΩ
Time	- - -	- - -	s
DAR	- - -	PI	- - -
	VPN	VPE	VNE
	0V	0V	0V
TMR	1500V	1.00MΩ	3s
MODE	V <sub>test</sub> .	Lim.	Time

6. Use the arrow keys ◀ or ▶ and select the position “Time”. The display shows the screen to the side.
7. Use the arrow keys (▲, ▼) to set the measuring time in the range: **3s ÷ 999s**

MΩ	15/10 – 18:04		
Vtest(-)	- - -		V
Ri(-)	- - -		MΩ
Time	- - -		s
DAR	- - -	PI	- - -
	VPN	VPE	VNE
	0V	0V	0V
TMR	1500V	1.00MΩ	3s
MODE	Vtest.	Lim.	Time

8. Connect the instrument to the PV string to be tested as shown in Fig. 7. The test can also be performed on several strings in parallel with each other. Remember that any surge arresters connected to the string cables must be disconnected and that it is advisable to measure upstream of any blocking diodes

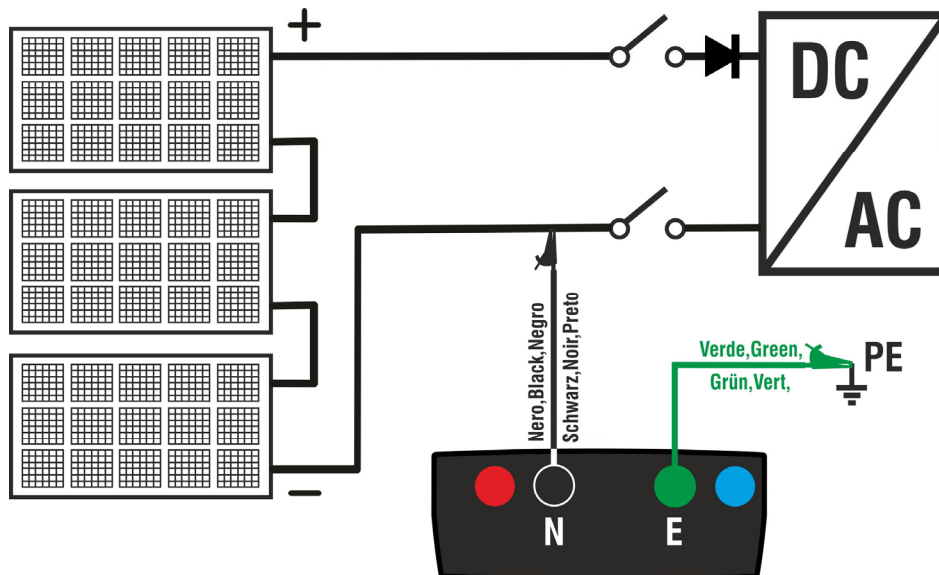

Fig. 7: Instrument connection for insulation measurement in TMR mode

### CAUTION



Upon pressing the **GO/STOP** key, different error messages can be displayed by the instrument (see § 6.2.3) and, therefore, the test cannot be started. Check and eliminate, if possible, the problem causing the error message before going on with the test.

9. **Press and hold the GO/STOP key for 2s** in order to start the test. In case no error conditions occur, the instrument displays the message “Measuring...” as shown in the screen to the side. In field “Vtest (-)”, the real test voltage generated by the instrument is shown.

MΩ	15/10 – 18:04		
Vtest(-)	- - -		V
Ri(-)	- - -		MΩ
Time	- - -		s
DAR	- - -	PI	- - -
	VPN	VPE	VNE
	0V	0V	0V
<b>Measuring...</b>			
TMR	1500V	1.00MΩ	700s
MODE	Vtest.	Lim.	Time

10. If “**Ri(-)≥Lim**”, the instrument shows the message “**OK**”, to indicate the **positive** result of measurement.

If the measuring time is  $\geq 60s$ , the instrument shows on the display the value of parameter **DAR** (Dielectric Absorption Ratio) (see § 11.2).

If the measuring time is  $\geq 600s$ , the instrument shows on the display both the value of parameter **DAR** (Dielectric Absorption Ratio) and the value of parameter **PI** (Polarization Index) (see § 11.1).

MΩ	15/10 – 18:04		
Vtest(-)	1540	V	
Ri(-)	>100	MΩ	
Time	600	s	
DAR	1.41	PI	1.02
	VPN	VPE	VNE
	0V	0V	0V
<b>OK</b>			
TMR	1500V	1.00MΩ	700s
MODE	Vtest.	Lim.	Time

Press the **SAVE** key to store the test result in the instrument’s memory (see § 7.1) or the **ESC/MENU** key to exit the screen without saving and go back to the main measuring screen.

### 6.2.3. Anomalous situations

- In case the instrument detects one of the following conditions: “ $|VPN| > 1500V$ ”, “ $|VPE| > 1500V$ ” or “ $|VNE| > 1500V$ ”, it stops the measurement, gives out a long sound, and the message “**V>LIM**” is shown on the display. Check the output voltage from the PV string.

MΩ	15/10 – 18:04		
	(+)	(-)	
Vtest	- - -	- - -	V
Ins.re	- - -	- - -	MΩ
	Rp	- - -	MΩ
	VPN	VPE	VNE
	> 1500V	- 750V	758V
<b>V &gt; LIM</b>			
DUAL	1500V	1.00MΩ	
MODE	Vtest.	Lim.	

- In DUAL mode, in case the instrument, upon pressing the **GO/STOP** key, detects a voltage **VPN<0V**, it stops measuring, gives out a long sound and the message “**Reverse P-N**” is shown on the display. Check polarity and the instrument's connections to the PV string.

MΩ	15/10 – 18:04		
	(+)	(-)	
Vtest	- - -	- - -	V
Ins.re	- - -	- - -	MΩ
	Rp	- - -	MΩ
	VPN	VPE	VNE
	- 1480V	- 750V	748V
<b>Reverse P-N</b>			
DUAL	1500V	1.00MΩ	
MODE	Vtest.	Lim.	

- In DUAL mode, in case the instrument, upon pressing the **GO/STOP** key, detects a voltage **0<VPN<30V**, it stops measuring, gives out a long sound and the message “**VPN < LIM**” is shown on the display. Check the output voltage from the PV string which should be  $\geq 30V$

MΩ	15/10 – 18:04		
	(+)	(-)	
Vtest	- - -	- - -	V
Ins.re	- - -	- - -	MΩ
	Rp	- - -	MΩ
	VPN	VPE	VNE
	20V	- 750V	748V
<b>VPN &lt; LIM</b>			
DUAL	1500V	1.00MΩ	
MODE	Vtest.	Lim.	

- In DUAL mode, in case the instrument, upon pressing the **GO/STOP** key, detects that one of the following conditions on measured voltages:  
 $RMS(VPN) - |(VPN) DC| < 10$   
 $RMS(VPE) - |(VPE) DC| < 10$   
 $RMS(VNE) - |(VNE) DC| < 10$   
 is not satisfied (**presence of AC components on input voltages**), it stops measuring, gives out a long sound and the message “**VAC>LIM**” is shown on the display. Check the output voltages from the PV string.

MΩ	15/10 – 18:04		
	(+)	(-)	
Vtest	- - -	- - -	V
Ins.re	- - -	- - -	MΩ
	Rp	- - -	MΩ
	VPN	VPE	VNE
	1480V	- 750V	748V
<b>VAC &gt; LIM</b>			
DUAL	1500V	1.00MΩ	
MODE	Vtest.	Lim.	



5. In case the instrument detects that the voltage between the positive and negative poles is greater than the test voltage set, the message "**VPN>Vtest**" appears on the display and the instrument stops the test as it does not comply with the IEC/EN62446-1 guideline. Check the rated voltage of the system, change the parameter and Vtest if necessary and repeat the test

MΩ	15/10 – 18:04		
	(+)	(-)	
Vtest	1320	1510	V
Ins.re	>100	>100	MΩ
	Rp	>100	MΩ
	VPN	VPE	VNE
	1500V	-750V	748V
<b>VPN&gt;Vtest</b>			
DUAL	1500V	1.00MΩ	
MODE	Vtest.	Lim.	

6. In case the instrument detects that **Rp<Lim**, the message "**NOT OK**" is shown on the display.

MΩ	15/10 – 18:04		
	(+)	(-)	
Vtest	1540	1520	V
Ins.re	0.1	>100	MΩ
	Rp	0.1	MΩ
	VPN	VPE	VNE
	1500V	-750V	748V
<b>NOT OK</b>			
DUAL	1500V	1.00MΩ	
MODE	Vtest.	Lim.	

### 6.3. GFL – SEARCHING FOR CONDITIONS OF LOW INSULATION ON PV STRINGS

In GFL (Ground Fault Locator) function, the instrument is capable of providing an indication about the position of a possible single fault of low insulation located in a string of the installation due, for example, to infiltrations of water or humidity in the junction boxes of PV modules. The instrument measures input voltages and, according to the unbalance between V(+) and V(-) with respect to earth, it detects the assumed position of the fault on the string.

#### CAUTION

The GFL function allows obtaining correct results **ONLY** at the following conditions:



- Test carried out on a **single string** disconnected from the inverter, any dischargers and functional ground connections
- **Single fault** of low insulation located at any position in the string
- Insulation resistance of the single fault **<0.23MΩ**
- Due to the random nature of these faults, it is recommended to carry out the measurements in environmental conditions similar to those in which the fault was reported

- Position the cursor onto **GFL** by using the arrow keys (▲, ▼) and confirm with **ENTER**. The display shows the screen to the side. The indication “Rp” indicates the parallel of the insulation resistances of the positive (+) and negative (-) poles of the string being tested.

GFL		15/10 – 18:04		
Rp	- - -	MΩ		
VPN	VPE	VNE		
0V	0V	0V		
10	1500V	0.10MΩ		
NMOD	Vtest.	Lim.		

- Use the arrow keys ◀ or ▶ and select the position “**NMOD**” to set the number of modules of the string being tested.
- Use the arrow keys (▲, ▼) to select a number of modules between: **4 ÷ 35**

GFL		15/10 – 18:04		
Rp	- - -	MΩ		
VPN	VPE	VNE		
0V	0V	0V		
10	1500V	0.10MΩ		
NMOD	Vtest.	Lim.		

- Use the arrow keys ◀ or ▶ and select the position “**Vtest**” to set the test voltage.
- Use the arrow keys (▲, ▼) to select one of the following test voltages (Vnom): **250, 500, 1000, 1500VDC**. In compliance with the prescriptions of IEC/EN62446-1 it is recommended to set the test voltage  $V_{test} \geq V_{nom}$  of the system

GFL		15/10 – 18:04		
Rp	- - -	MΩ		
VPN	VPE	VNE		
0V	0V	0V		
10	1500V	0.10MΩ		
NMOD	Vtest.	Lim.		

- Use the arrow keys ◀ or ▶ and select the position “Lim.”. The display shows the screen to the side.
- Use the arrow keys (▲,▼) to set the **minimum** limit threshold for insulation measurement, which can be selected between: **0.05MΩ, 0.1MΩ, 0.23MΩ**

GFL	15/10 – 18:04		
Rp	- - -	MΩ	
VPN	0V	VPE	VNE
	0V		0V
10	1500V	0.10MΩ	
NMOD	Vtest.	Lim.	

- Connect the instrument to the PV string to be tested as shown in Fig. 8. Remember that any surge arresters connected to the string cables must be disconnected and that it is advisable to measure upstream of any blocking diodes

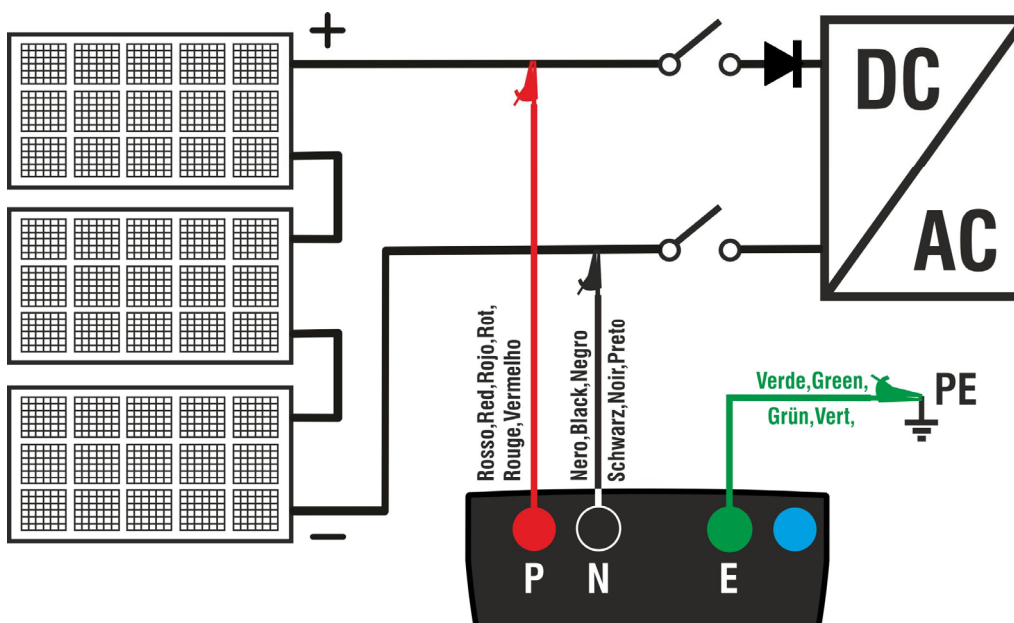

Fig. 8: Instrument connection for insulation measurement in GFL mode

### CAUTION



Upon pressing the **GO/STOP** key, different error messages can be displayed by the instrument (see § 6.2.3) and, therefore, the test cannot be started. Check and eliminate, if possible, the problem causing the error message before going on with the test.

- Press and hold the GO/STOP key for 2s** in order to start the test (insulation measurement in DUAL mode). In case no error conditions occur, the instrument displays the message “Measuring...” as shown in the screen to the side.

GFL	15/10 – 18:04		
Rp	- - -	MΩ	
VPN	0V	VPE	VNE
	0V		0V
Measuring...			
10	1500V	0.10MΩ	
NMOD	Vtest.	Lim.	

10. **With no fault conditions ( $R_p \geq \text{Lim}$ )**, the instrument shows the screen to the side and the message “OK” appears on the display.

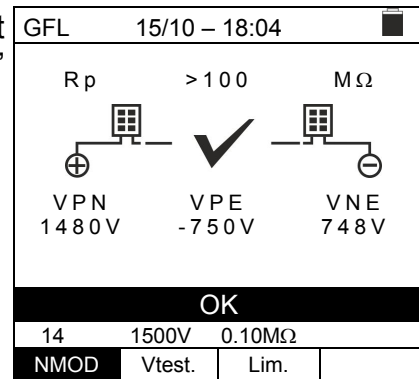

11. **In case a fault is present ( $R_p < \text{Lim}$ ) in position 0 (upstreams of the first module)**, the instrument shows the screen to the side and the message “GND: Fault (+)..1” on the display. Check the insulation state of the conductor (+) coming from the string

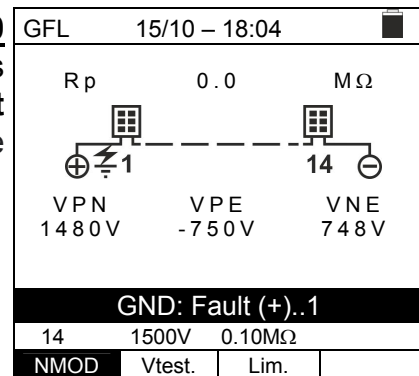

12. **In case a fault is present ( $R_p < \text{Lim}$ ) in position NMOD+1 (downstream of the last module)**, the instrument shows the screen to the side and the message “GND: Fault NMOD..(-)” on the display. Check the insulation state of the conductor (-) coming from the string

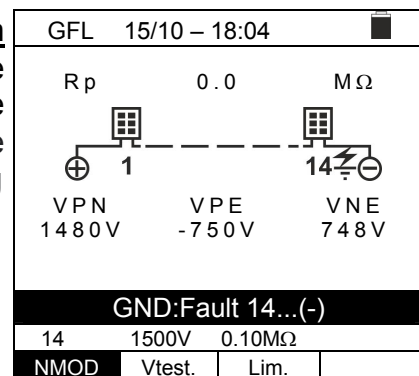

13. **In case a fault is present ( $R_p < \text{Lim}$ ) in position 1 (between module 1 and 2)**, the instrument shows the screen to the side and the message “GND: Fault 1..2” on the display. Check the state of insulation of the junction boxes of the modules indicated (1 and 2 in the example) and related connection cables

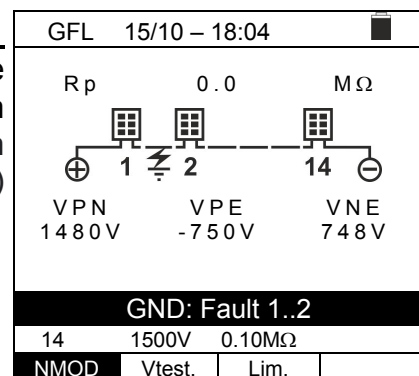

14. **In case a fault is present ( $R_p < \text{Lim}$ ) in position NMOD (between the second last and the last module),** the instrument shows the screen to the side and the message “**GND:Fault NMOD-1..NMOD**” on the display. Check the state of insulation of the junction boxes of the modules indicated and related connection cables

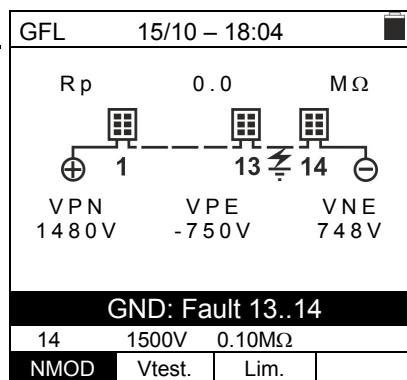

15. **In case a fault is present ( $R_p < \text{Lim}$ ) within the string,** the instrument shows the screen to the side and the message (relevant to the example with NMOD = 14) “**GND: Fault 8..9**” on the display. Check the state of insulation of the junction boxes of the modules indicated and related connection cables

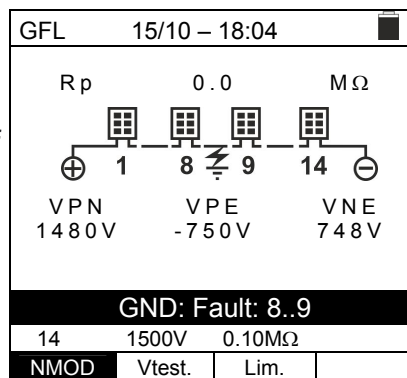

### CAUTION

**The results of function GFL cannot be saved in the instrument's memory.**

#### 6.4. DMM – MULTIMETER FUNCTION

In this function, the instrument shows the RMS and DC values of voltages between the positive (+) and negative (-) pole, between the positive (+) pole and earth connection and between the negative (-) pole and earth connection, in order to check for the presence of AC components on input voltages.

1. Position the cursor onto **DMM** by using the arrow keys (**▲**, **▼**) and confirm with **ENTER**. The display shows the screen to the side.

DMM 15/10 – 18:04 		
VPNrms	0	V
VPErms	0	V
VNErms	0	V
VPNdc	0	V
VPEdc	0	V
VNEdc	0	V

2. Connect the instrument to the PV string to be tested as shown in Fig. 8.

3. The voltage values are shown on the display as illustrated in the screen to the side.

DMM 15/10 – 18:04 		
VPNrms	1480	V
VPErms	750	V
VNErms	748	V
VPNdc	1420	V
VPEdc	720	V
VNEdc	-726	V



#### CAUTION

The results of function DMM cannot be saved in the instrument's memory.

## 7. STORING RESULTS

The instrument allows saving max 999 measured values. The saved data can be recalled to the display and deleted at any moment, and, upon saving, they can be associated with up to a maximum of 3 levels of numeric markers relevant to the installation name, the PV string and the PV module (with max value 250). For each level, 20 marker names are available, which can be customized by the user, if needed, **through PC connection with the provided management software**. It is also possible to add a comment associated with each measure.

### 7.1. SAVING MEASURES

1. Press the **SAVE/ENTER** key with the measured result on the display. The screen to the side appears on the display. It contains:

- Item “Measurement” which identifies the first available memory location
- The first marker (e.g.: “Installation”) to which a numeric value between 1 ÷ 250 can be associated
- The second marker (e.g.: “String”) to which a numeric value between 0 (- - -) ÷ 250 can be associated
- The third marker (e.g.: “Module”) to which a numeric value between 0 (- - -) ÷ 250 can be associated
- Item “Comment” associated with the measure, in which a text of **max 30 digits** can be entered.

SAVE 15/10 – 18:04	
Measure	003
Installation	<b>001</b>
String	---
Module	---
Comment: max 30 digits	

2. Use the arrow keys ◀ or ▶ to select the marker and the arrow keys (▲, ▼) to change the label of the associated numeric value (e.g.: “Area”) among those available or customizable by the user (max 20 names).

3. Select item “Comment” and press the **SAVE/ENTER** key to enter the desired text. The following screen with virtual keyboard appears on the display:

SAVE 15/10 – 18:04	
Measure	003
<b>Area</b>	001
String	---
Module	---
<b>Comment:</b>	max 30 digits

4. Use the arrow keys ◀ or ▶ to move the cursor to the selected digit and press the **SAVE/ENTER** key to enter comment.

5. Move the cursor to “DEL” and press the **SAVE/ENTER** key to delete the selected digit.

6. Move the cursor to “END” and press the **SAVE/ENTER** key to confirm the written comment and go back to the previous screen.

SAVE 15/10 – 18:04	
Keyboard	
COMMENT	
0 1 2 3 4 5 6 7 8 9 0 ( ) %	
Q W E R T Y U I <b>█</b> P <=> #	
A S D F G H J K L + - * / &	
Z X C V B N M . , ; : ! ? _	
Ä Ö Ü ß µ Ñ Ç Á Í Ó Ú Û Ü ÿ	
Á È É Ù Ç Ä Ë Ì Ö Ü Æ Ø Å	
CANC	<b>END</b>

7. Press the **SAVE/ENTER** key to confirm saving the measure or **ESC/MENU** to exit without saving.

## 7.2. RECALL OF DATA TO DISPLAY AND MEMORY DELETION

- Position the cursor onto **MEM** by using the arrow keys (**▲**, **▼**) and confirm with **ENTER**. The screen to the side appears on the display. The screen contains:
  - The number of the memory location where the measure is saved
  - The date in which the measure was saved
  - The type of measure saved
  - The total number of saved measures for each screen and the residual available memory

MEM 15/10 – 18:04		
N.	Date	Type
001	15/09/20	RPE
002	16/09/20	RPE
003	17/09/20	RPE
004	18/09/20	MΩ
005	19/09/20	MΩ
006	19/09/20	MΩ
007	19/09/20	MΩ
Tot: 007		Free: 992
↑↓	↑↓	Tot
Rec	Pag	DEL

- Use the arrow keys (**▲**, **▼**) to select the measure to be recalled to display.
- Press the **SAVE/ENTER** key to display the saved measure. Press the **ESC/MENU** key to go back to the previous screen.
- Use the arrow keys **◀** or **▶** to select option “Pag” and proceed to the next screen.
- Select the option “DEL” to delete the whole content of the instrument's memory. The following screen appears on the display:

MEM 15/10 – 18:04		
N.	Date	Type
001	15/09/20	RPE
002	16/09/20	RPE
003	17/09/20	RPE
004	18/09/20	MΩ
005	19/09/20	MΩ
006	19/09/20	MΩ
007	19/09/20	MΩ
Tot: 007		Free: 992
↑↓	↑↓	Tot
Rec	Pag	DEL

- Press the **SAVE/ENTER** key to confirm data deletion. The message “**Memory empty**” is shown on the display.
- Press the **MENU/ESC** key to exit the function and go back to the general menu.

MEM 15/10 – 18:04		
DELETE ALL?		
ENTER / ESC		



## 8. CONNECTING THE INSTRUMENT TO THE PC

### CAUTION



- The connection between instrument and PC is realized by means of cable C2006.
- In order to transfer the data onto a PC, it is necessary to install beforehand both the management software and the drivers of cable C2006 on the PC itself.
- Before connecting, it is necessary to select the port to be used and the correct baud rate (57600 bps) on the PC. To set these parameters, launch the provided management software and refer to the program's on-line help.
- The selected port must not be engaged by other devices or applications, e.g. a mouse, a modem, etc. Close any applications running using the Microsoft Windows Task Manager function, if necessary.
- The optical port emits invisible LED radiations. Do not directly observe with optical instruments. Class 1M LED apparatus according to standard IEC/EN 60825-1.

To transfer data to the PC, follow this procedure:

1. Switch on the instrument by pressing the **ON/OFF** key.
2. Connect the instrument to the PC via the provided optical/USB cable **C2006**.
3. Press the **ESC/MENU** key to open the main menu.
4. Use the arrow keys (**▲**, **▼**) to select "**PC**", to access data transfer mode and confirm with **SAVE/ENTER**.

MENU	15/10 – 18:04	
DMM	: Voltage	
MΩ	: Insulation:	
GFL	: Find Insul. fault	
RPE	: Continuity	
SET	: Settings	
MEM	: Data saved	
PC	: Data transfer	

5. The instrument shows the following screen:

PC	15/10 – 18:04	
PC CONNECTION		

6. Use the software controls to activate data transfer (please refer to the on-line help of the program).

## 9. MAINTENANCE

### 9.1. GENERAL INFORMATION

The instrument you purchased is a precision instrument. While using and storing the instrument, carefully observe the recommendations listed in this manual in order to prevent possible damage or danger during use. Do not use the instrument in environments with high humidity levels or high temperatures. Do not expose to direct sunlight. Always switch off the instrument after use. In case the instrument is not to be used for a long time, remove the batteries to avoid liquid leaks that could damage the instruments internal circuits.

### 9.2. BATTERY REPLACEMENT

When the low battery symbol “” appears on the LCD display, or if during a test the instrument shows the message “low battery”, it is necessary to replace the internal batteries.



#### CAUTION

Only expert and trained technicians should perform this operation. Before carrying out this operation, make sure you have disconnected all cables from the input terminals.

1. Switch off the instrument by pressing and holding the ON/OFF key.
2. Remove the cables from the input terminals.
3. Loosen the battery compartment cover fastening screw and remove the cover.
4. Remove all the batteries from the battery compartment and replace them only with new batteries of the same type only (see § 10.2.3), making sure to respect the indicated polarities.
5. Restore the battery compartment cover into place and fasten it by means of the relevant screw.
6. Do not scatter old batteries into the environment. Use the relevant containers for disposal.

### 9.3. CLEANING THE INSTRUMENT

Use a soft and dry cloth to clean the instrument. Never use wet cloths, solvents, water, etc.

### 9.4. END OF LIFE



**WARNING:** this symbol indicates that the appliance, its accessories and the internal batteries must be collected separately and correctly disposed of.

## 10. TECHNICAL SPECIFICATIONS

### 10.1. TECHNICAL CHARACTERISTICS

Accuracy is indicated as [%reading + (no. of digits) \* resolution] at 23°C ± 5°C, <80%RH

#### DC Voltage

Range [V]	Resolution [V]	Accuracy
3 ÷ 1500	1	±(1.0%reading + 2digits)

#### AC TRMS Voltage

Range [V]	Resolution [V]	Accuracy
3 ÷ 1000	1	±(1.0%reading + 3digits)

Frequency range: 42.5 ÷ 69Hz ; Voltages zeroed for measured value <3V

#### Insulation Resistance (MΩ) R(+), R(-), Rp – DUAL mode

Test voltage DC [V]	Range [MΩ]	Resolution [MΩ]	Accuracy (*)
250, 500, 1000, 1500	0.1 ÷ 0.99	0.01	±(5.0%reading + 5digits)
	1.0 ÷ 19.9	0.1	
	20 ÷ 100	1	

(\*) Accuracy given for VPN≥240V, Rfault≥10Ω. Accuracy of Rp and R(+) not declared if R(+)≥0.2MΩ and R(-)<0.2MΩ→, Accuracy of Rp and R(-) not declared if R(+) <0.2MΩ and R(-) ≥0.2MΩ

Open circuit voltage <1.25 x rated test voltage  
 Short-circuit current <15mA (peak) for each test voltage  
 Rated test current > 1mA on R = 1kΩ x Vnom (with VPN, VPE, VNE= 0)

#### Insulation resistance (MΩ) – TIMER mode

Test voltage DC [V]	Range [MΩ]	Resolution [MΩ]	Accuracy
250, 500, 1000, 1500	0.01 ÷ 9.99	0.01	±(5.0%reading + 5digits)
	10.0 ÷ 99.9	0.1	

Open circuit voltage <1.25 x rated test voltage  
 Short-circuit current < 15mA (peak) for each test voltage  
 Rated test current > 1mA on R = 1kΩ x Vnom (with VPN, VPE, VNE= 0)  
 Selectable Timer: 3s ÷ 999s

#### Continuity of protective conductors (RPE)

Range [Ω]	Resolution [Ω]	Accuracy
0.00 ÷ 9.99	0.01	±(2.0%reading + 2digits)
10.0 ÷ 99.9	0.1	
100 ÷ 1999	1	

Test current: >200mA DC up to 5Ω (cables included), resolution 1mA, accuracy ±(5.0%reading + 5digits)  
 Open-circuit voltage 4 < V<sub>0</sub> < 10V

#### GFL – Ground Fault Locator

Test voltage DC [V]	Range [MΩ]	Resolution [MΩ]	Accuracy Rp(*)	Position accuracy
250, 500, 1000, 1500	0.1 ÷ 0.99	0.01	±(5.0%rdg + 5dgt)	± 1module
	1.0 ÷ 19.9	0.1		
	20 ÷ 100	1		

(\*) Accuracy given for VPN≥240V, Rfault≥10Ω. Accuracy of Rp and R(+) not declared if R(+)≥0.2MΩ and R(-)<0.2MΩ→, Accuracy of Rp and R(-) not declared if R(+) <0.2MΩ and R(-) ≥0.2MΩ

Open circuit voltage <1.25 x rated test voltage  
 Short-circuit current <15mA (peak) for each test voltage  
 Rated test current > 1mA on R = 1kΩ x Vnom (with VPN, VPE, VNE= 0)  
 Limit threshold on measurement: 0.05MΩ, 0.1MΩ, 0.23MΩ ; Number of set modules: 4 ÷ 35

The GFL function allows obtaining correct results **ONLY** at the following conditions:

- Test carried out on a **single string** disconnected from the inverter, any dischargers and functional ground connections
- **Single fault** of low insulation located at any position in the string
- Insulation resistance of the single fault <**0.23MΩ**
- Due to the random nature of these faults, it is recommended to carry out the measurements in environmental conditions similar to those in which the fault was reported

## 10.2. GENERAL CHARACTERISTICS

### 10.2.1. Reference guidelines

Instrument safety:	IEC/EN61010-1, IEC/EN61010-2-030, IEC/EN61010-2-033, IEC/EN61010-2-034
EMC:	IEC/EN61326-1
Safety of measuring accessories:	IEC/EN61010-031
General:	IEC/EN62446-1
Measurement MΩ:	IEC/EN61557-2
Measurement RPE:	IEC/EN61557-4
Insulation:	double insulation
Pollution level:	2
Measurement category:	CAT III 1500V DC, CAT III 1000V AC, Max 1500VDC, 1000V AC between inputs

### 10.2.2. Display and memory

Type of display:	graphic COG 128x128 pxl, with backlighting
Saved data:	max 999 tests
PC interface:	optical/USB

### 10.2.3. Power supply

Battery type:	6x1.5V alkaline type AA LR06 or 6x1.2V NiMH rechargeable batteries type AA LR06
Low battery indication:	symbol "□" on the display
Battery duration:	> 500 test (for each function)
Auto power off:	after 5 minutes' idling

### 10.2.4. Mechanical characteristics

Size (L x W x H)	235 x 165 x 75mm (9 x 6 x 3in)
Weight (batteries included):	1.2kg (2.5lv)
Mechanical protection:	IP40

## 10.3. ENVIRONMENTAL CONDITIONS FOR USE

Reference temperature:	23°C ± 5°C (73°F ± 41°F)
Operating temperature:	0°C ÷ 40°C (32°F ÷ 104°F)
Allowable relative humidity:	<80%RH
Storage temperature:	-10°C ÷ 60°C (14°F ÷ 140°F)
Storage humidity:	<80%RH
Max operating altitude:	2000m (6562ft)

**This instrument satisfies the requirements of Low Voltage Directive 2014/35/EU (LVD) and of EMC Directive 2014/30/EU**  
**This instrument satisfies the requirements of European Directive 2011/65/EU (RoHS) and 2012/19/EU (WEEE).**

## 10.4. ACCESSORIES

See the attached packing list.

## 11. APPENDIX – THEORETICAL OUTLINE

### 11.1. MEASUREMENT OF POLARIZATION INDEX (PI)

The purpose of this diagnostic test is to evaluate the influence of the polarization effects. Upon the application of a high voltage to insulation, the electric dipoles distributed in the insulation align in the direction of the applied electric field. This phenomenon is called polarization. Because of the polarized molecules, a polarization (absorption) current generates, which lowers the total value of insulation resistance.

Parameter **PI** consists in the ratio between the value of insulation resistance measured after 1 minute and after 10 minutes. The test voltage is maintained throughout the whole duration of the test and, at the end, the instrument provides the value of ratio:

$$PI = \frac{Ins.re (10 \text{ min})}{Ins.re (1 \text{ min})}$$

Some reference values:

PI Value	Insulation condition
from 1.0 to 1.25	Not acceptable
from 1.4 to 1.6	Good
>1.6	Excellent

### 11.2. DIELECTRIC ABSORPTION RATIO (DAR)

Parameter **DAR** consists in the ratio between the value of insulation resistance measured after 30s and after 1 minute. The test voltage is maintained throughout the whole duration of the test and, at the end, the instrument provides the value of ratio:

$$DAR = \frac{Ins.re (1 \text{ min})}{Ins.re (30s)}$$

Some reference values:

DAR Value	Insulation condition
< 1.0	Dangerous
from 1.0 to 2.0	Questionable
from 2.0 to 4.0	Good
> 4.0	Excellent

## 12. ASSISTANCE

### 12.1. WARRANTY CONDITIONS

This instrument is warranted against any material or manufacturing defect, in compliance with the general sales conditions. During the warranty period, defective parts may be replaced. However, the manufacturer reserves the right to repair or replace the product. Should the instrument be returned to the After-sales Service or to a Dealer, transport will be at the Customer's charge. However, shipment will be agreed in advance. A report will always be enclosed to a shipment, stating the reasons for the product's return. Only use original packaging for shipment; any damage due to the use of non-original packaging material will be charged to the Customer. The manufacturer declines any responsibility for injury to people or damage to property.

The warranty shall not apply in the following cases:

- Repair and/or replacement of accessories and battery (not covered by warranty).
- Repairs that may become necessary as a consequence of an incorrect use of the instrument or due to its use together with non-compatible appliances.
- Repairs that may become necessary as a consequence of improper packaging.
- Repairs which may become necessary as a consequence of interventions performed by unauthorized personnel.
- Modifications to the instrument performed without the manufacturer's explicit authorization.
- Use not provided for in the instrument's specifications or in the instruction manual.

The content of this manual cannot be reproduced in any form without the manufacturer's authorization.

**Our products are patented and our trademarks are registered. The manufacturer reserves the right to make changes in the specifications and prices if this is due to improvements in technology.**

### 12.2. ASSISTANCE

If the instrument does not operate properly, before contacting the After-sales Service, please check the conditions of batteries and cables and replace them, if necessary. Should the instrument still operate improperly, check that the product is operated according to the instructions given in this manual. Should the instrument be returned to the After-sales Service or to a Dealer, transport will be at the Customer's charge. However, shipment will be agreed in advance. A report will always be enclosed to a shipment, stating the reasons for the product's return. Only use original packaging for shipment; any damage due to the use of non-original packaging material will be charged to the Customer.



YAMUM0077HT0