



IDS 401

Intelligent Electronic Pressure Switch Stainless Steel

Ceramic Sensor

accuracy according to IEC 60770:
0.5 % FSO

Nominal pressure

from 0 ... 400 mbar up to 600 bar

Contacts

1 or 2 independent PNP contacts,
freely configurable

Analogue output

2-wire: 4 ... 20 mA
3-wire: 4 ... 20 mA / 0 ... 10 V
others on request

Special characteristics

- ▶ indication of measured values on a 4-digit LED display
- ▶ rotatable and configurable display module

Optional versions





- ▶ **IS-version**
Ex ia = intrinsically safe for gases and dust
- ▶ pressure port PVDF
- ▶ customer specific versions

The electronic pressure switch IDS401 is the successful combination of

- ▶ intelligent pressure switch
- ▶ digital display

and has been specially designed for universal usage in industry applications; with flush diaphragm the IDS401 is suitable for the usage in viscous, pasty or highly contaminated media. The rotatable stainless steel housing is predestined for rough conditions and difficult installing conditions, caused by the high functionality and robustness. As standard the IDS401 offers a PNP contact and is optionally available with a second, independent contact. Additionally the IDS401 could be equipped with an analogue output

Preferred areas of use are

-  Plant and Machine Engineering
-  Environmental Engineering (water – sewage – recycling)
-  Water
-  Hydraulic Oil

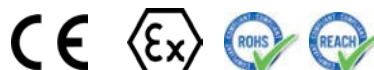

Input pressure ranges																		
Nominal pressure gauge [bar]	-1...0	0.4	0.6	1	1.6	2.5	4	6	10	16	25	40	60	100	160	250	400	600
Nominal pressure abs. [bar]	-	-	0.6	1	1.6	2.5	4	6	10	16	25	40	60	100	160	250	400	600
Level gauge [mH ₂ O]	-	4	6	10	16	25	40	60	100	160	250	400	600	-	-	-	-	-
Overpressure [bar]	4	1	2	2	4	4	10	10	20	40	40	100	100	200	400	400	600	800
Burst pressure ≥ [bar]	7	2	4	4	5	5	12	12	25	50	50	120	120	250	500	500	650	880
Vacuum resistance	P _N ≥ 1 bar: unlimited vacuum resistance P _N < 1 bar: on request																	

Contact ¹	
Number, type	standard: 1 PNP contact option: 2 independent PNP contacts
Max. switching current	4 ... 20 mA / 2- and 3-wire: contact rating 125 mA, short-circuit resistant; V _{Switch} = V _S - 2V 0 ... 10 V / 3-wire: contact rating 125 mA, short-circuit resistant
Accuracy of contacts ²	≤ ± 0.5 % FSO
Repeatability	≤ ± 0.2 % FSO
Switching frequency	2-wire: max. 10 Hz / 3-wire: 50 Hz
Switching cycles	> 100 x 10 ⁶
Delay time	0 ... 100 sec

¹ with Ex-protection max. 1 contact possible

² accuracy according to IEC 60770 – limit point adjustment (non-linearity, hysteresis, repeatability)

Analogue output (optionally) / Supply	
2-wire current signal	4 ... 20 mA / V _S = 13 ... 36 V _{DC} permissible load: R _{max} = [(V _S - V _{Smin}) / 0.02 A] Ω response time: < 10 msec
2-wire current signal, Ex-protection	4 ... 20 mA / V _S = 15 ... 28 V _{DC} permissible load: R _{max} = [(V _S - V _{Smin}) / 0.02 A] Ω response time: < 10 msec
3-wire current signal	4 ... 20 mA / V _S = 24 V _{DC} ± 10 % adjustable (turn-down of span 1:5) ³ permissible load: R _{max} = 500 Ω response time: < 30 msec
3-wire voltage signal	0 ... 10 V / V _S = 24 V _{DC} ± 10 % adjustable (turn-down of span 1:5) ³ permissible load: R _{min} = 10 kΩ response time: < 30 msec
Without analogue output	V _S = 15 ... 36 V _{DC}
Accuracy ²	≤ ± 0.5 % FSO

³ with turn-down of span the analogue signal is adjusted automatically to the new measuring range

Thermal effects (Offset and Span) / Permissible temperatures	
Thermal error	≤ ± 0.2 % FSO / 10 K
in compensated range	-25 ... 85 °C
Permissible temperatures	medium: -40 ... 125 °C electronics / environment: -40 ... 85 °C storage: -40 ... 100 °C

⁴ for pressure port of PVDF the minimum permissible temperature is -30 °C

Electrical protection	
Short-circuit protection	permanent
Reverse polarity protection	no damage, but also no function
Electromagnetic compatibility	emission and immunity according to EN 61326

Mechanical stability	
Vibration	10 g RMS (25 ... 2000 Hz) according to DIN EN 60068-2-6
Shock	500 g / 1 msec according to DIN EN 60068-2-27

Materials	
Pressure port / housing	1.4404 (316L) PVDF (for P _N ≤ 60 bar, G1/2" open port)
Housing	1.4404 (316L)
Display housing	stainless steel 1.4301 (304)
Viewing glass	laminated safety glass
Seals	standard: FKM option: EPDM (P _N ≤ 160 bar) others on request
Diaphragm	ceramics Al ₂ O ₃ 96 %
Media wetted parts	pressure port, seals, diaphragm

Explosion protection (only for 4 ... 20 mA / 2-wire)	
Approval AX14-DS 401	IBExU06ATEX1050 X zone 0: II 1G Ex ia IIC T4 Ga (connector) / II 1G Ex ia IIB T4 Ga (cable) zone 20: II 1D Ex ia IIIC T135 °C Da
Safety technical maximum values	U _i = 28 V, I _i = 93 mA, P _i = 660 mW, C ≈ 0 nF, L _i ≈ 0 μH
Max. switching current ⁵	70 mA
Permissible temperatures for environment	-20 ... 60 °C with p _{atm} 0.8 bar up to 1.1 bar
Connecting cables (by factory)	cable capacitance: signal line/shield also signal line/signal line: 100 pF/m cable inductance: signal line/shield also signal line/signal line: 1 μH/m

⁵ the real switching current in the application depends on the power supply unit

Miscellaneous	
Display	4-digit, 7-segment-LED display, visible range 37.2 x 11 mm; digit height 10 mm, range of indication -1999 ... +9999; accuracy 0.1 % ± 1 digit; digital damping 0.3 ... 30 sec (programmable); measured value update 0.0 ... 10 sec (programmable)
Option oxygen application ⁶	for P _N ≤ 15 bar: O-ring in 70 EPDM 281 (with BAM-approval); permissible maximum values are 15 bar / 60° C and 10 bar / 90° C for P _N ≤ 25 bar: O-ring in FKM Vi 567 (with BAM-approval); permissible maximum values are 25 bar / 150° C
Current consumption (without contacts)	2-wire signal output current: max. 25 mA 3-wire signal output current: approx. 30 mA + signal current 3-wire signal output voltage: approx. 30 mA
Ingress protection	IP 67
Installation position	any
Weight	approx. 400 g
Operational life	> 100 x 10 ⁶ pressure cycles
CE-conformity	EMC Directive: 2014/30/EU Pressure Equipment Directive: 97/23/EC (module A) ⁷
ATEX-Richtlinie	94/9/EG

⁶ not possible with flush pressure ports

⁷ This directive is only valid for devices with maximum permissible overpressure > 200 bar

Wiring diagrams

2-wire-system (current)

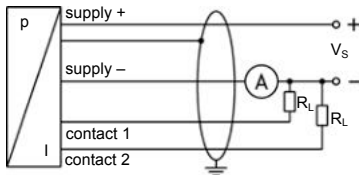

3-wire-system (current / voltage)

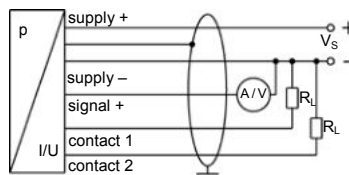

Pin configuration

Electrical connections	M12x1 metal (5-pin)
Supply +	1
Supply -	3
Signal + (only 3-wire)	2
Contact 1	4
Contact 2	5
Shield	plug housing / pressure port

Electrical connections (dimensions in mm)

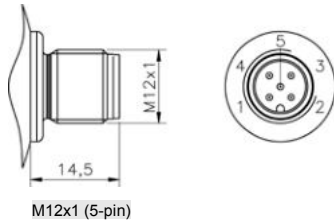

M12x1 (5-pin)

Design ⁸

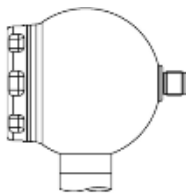

side display

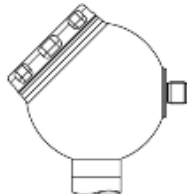

45° display (on request)

⁸ all designs in horizontal rotatable housing as standard

Mechanical connections (dimensions in mm)

standard

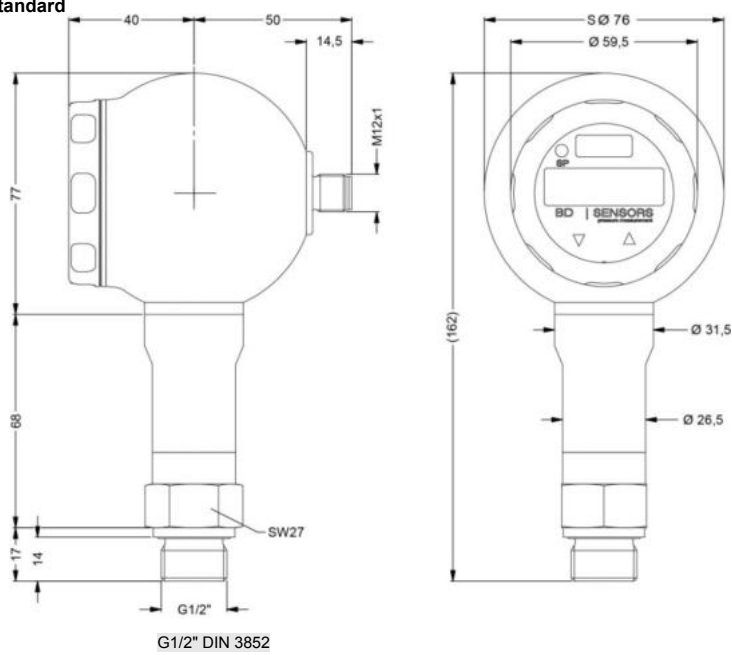

optionally

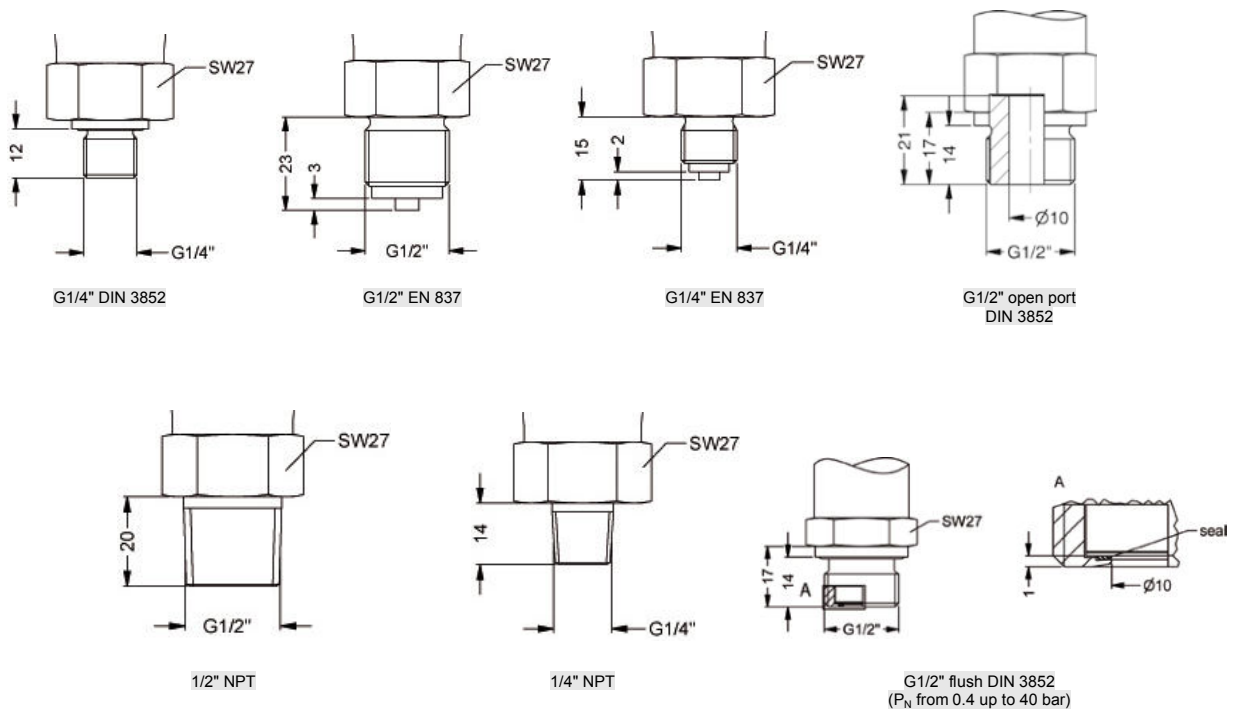

⇒ metric threads and other versions on request

Ordering code IDS 401

IDS 401

 - - - - - - - - - -

Pressure										
gauge		7	A	2						
gauge in mH ₂ O		7	A	E						
absolute		7	A	3						
Input										
	[mH ₂ O]	[bar]								
	4	0.4	4	0	0	0				
	6	0.6	6	0	0	0				
	10	1.0	1	0	0	1				
	16	1.6	1	6	0	1				
	25	2.5	2	5	0	1				
	40	4.0	4	0	0	1				
	60	6.0	6	0	0	1				
	100	10	1	0	0	2				
	160	16	1	6	0	2				
	250	25	2	5	0	2				
	400	40	4	0	0	2				
	600	60	6	0	0	2				
	100		1	0	0	3				
	160		1	6	0	3				
	250		2	5	0	3				
	400		4	0	0	3				
	600		6	0	0	3				
	-1 ... 0		X	1	0	2				
	customer		9	9	9	9				consult
Design										
	Stainless steel globe housing (side display)						K	H		
	Stainless steel globe housing (45° display)						K	4		consult
Analogue output										
	without								0	
	4 ... 20 mA / 2-wire								1	
	0 ... 10 V / 3-wire, adjustable								3J	
	4 ... 20 mA / 3-wire, adjustable								7J	
	Intrinsic safety 4 ... 20 mA / 2-wire								E	
	customer								9	consult
Contact										
	1 contact								1	
	2 contacts								2	
Accuracy										
	0.5 %								5	
	customer								9	consult
Electrical connection										
	Male plug M12x1 (5-pin) / metal version								N 1 1	
	customer								9 9 9	consult
Mechanical connection										
	G1/2" DIN 3852								1 0 0	
	G1/2" EN 837								2 0 0	
	G1/4" DIN 3852								3 0 0	
	G1/4" EN 837								4 0 0	
	G1/2" DIN 3852 with flush sensor								F 0 0	
	G1/2" DIN 3852 open pressure port								H 0 0	
	1/2" NPT								N 0 0	
	1/4" NPT								N 4 0	
	customer								9 9 9	consult
Seals										
	FKM								1	
	EPDM								3	
	customer								9	consult
Pressure port										
	Stainless steel 1.4404 (316L)								1	
	PVDF								B	
	customer								9	consult
Diaphragm										
	Ceramics Al ₂ O ₃ 96%								2	
	customer								9	consult
Special version										
	standard								0 0 0	
	oxygen application								0 0 7	
	customer								9 9 9	consult
Prices EXW Thierstein, excluding package										

¹ with Ex version max. 1 contact is possible

² G1/2" flush up to 25 bar and nominal pressure abs. on request

³ possible for nominal pressure ranges P_N ≤ 160 bar

⁴ PVDF only with G1/2" DIN 3852 open pressure port (up to 60 bar); Ex-protection not possible, (min. permissible temperature -30°C)

⁵ oxygen application with FKM-seal up to 25 bar or with EPDM-seal up to 15 bar possible