

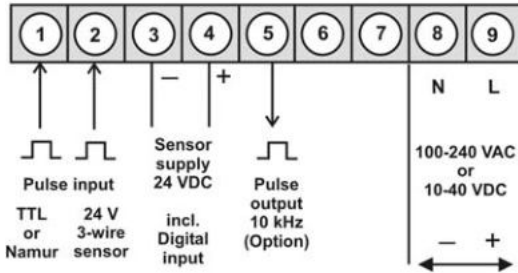

IMB2 – 5-digit digital panel meter in 96x96 (BxH) with Bargraph 270° Frequency 0,01 Hz to 999,99 kHz

- red display of -19999...99999 digits
- red 55 dots bargraph
- adjustable bars or dot operation or operation with permanent display of plate centre
- small installation depth: 56 mm without plug-in screw terminal
- multi voltage power supply unit 100-240 VAC, alternatively 10-40 VDC
- adjustment via factory setting or directly on the sensor signal
- min/max-memory with adjustable permanent display
- 30 additional adjustable support points
- display flashing at threshold value exceedance / undercut
- Schmitt-Trigger-Input
- digital frequency filter for contact bounce suppression and interference suppression
- frequency filter with different pulse-duty factor
- zero-key for triggering of Hold, Tara, display change, setpoint setting, alarm actuator
- flexible alarm system with adjustable delay times
- volume measurement (Totaliser) for frequencies up to 1kHz (exact pulse)
- mathematical functions like reciprocal value, square root, square and rounding
- constant setting / setpoint setting
- sliding averaging
- brightness control via parameter or front keys
- programming interlock via access code
- protection class IP65 at the front
- plug-in screw terminal
- 2 relay outputs
- sensor supply
- digital input for the triggering of Hold, Tara, display change, setpoint setting, alarm actuator
- optional: 1 independently scalable analog output
- optional: interface RS232 or RS485
- accessories: pc-based configuration-kit PM-TOOL with CD & USB adapter
- on demand: devices for working temperatures of -25°C...60°C

• Frequency (0.01 Hz to 999.99 kHz)



Supply 100-240 VAC, DC ± 10%

Supply 10-40 VDC, 18-30 VAC

ORDER NUMBER

(without options)

EUR

IMB2-2FR5RR.0307.S72AD 420,00

IMB2-2FR5RR.0307.W72AD 420,00

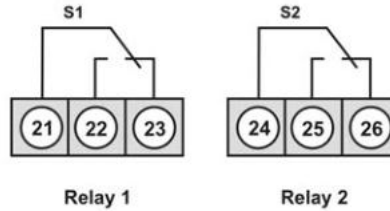
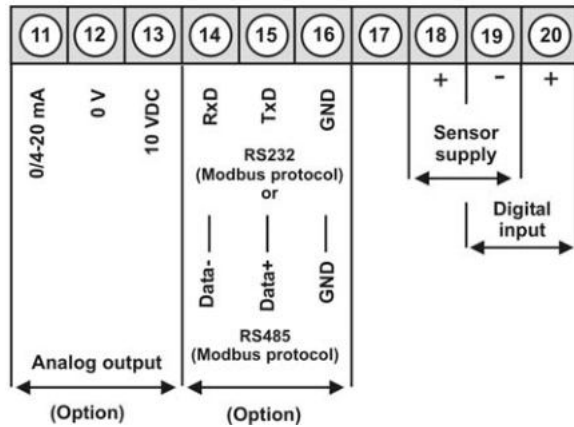

Advice:

Using Namur sensors with a nominal voltage of approx. 8 V, a sensor supply of 12 VDC needs to be provided. For devices with sensor supply terminals 4 and 18 as well as 3 and 19 are galvanic connected in the device.

• Order key options

IM	B	2-	2	F	R	5	R	R.	0	3	0	7.	S	7	2	A	D
IM	B	2-	2	F	R	5	R	R.	0	3	0	7.	W	7	2	A	D

		EUR
X	Analog output 0/4-20 mA, 0-10 VDC galv. isolated	120,00
6	Sensor supply 12 VDC / 50 mA incl. digital input	15,35
K	Pulse output	10,00
3	Interface RS232 galv. isolated	70,00
4	Interface RS485 galv. isolated	70,00
B	Blue display	on demand
G	Green display	12,50
Y	Orange display	on demand

For devices with sensor supply, terminal 4 and 18 as well as 3 and 19 are galvanic connected inside the device.

ORDER NUMBER

EUR

• Parameterisation software

PC based configuration software PM-Tool for devices without keypad, for a simple adjustment of standard devices, incl. CD & USB-adapter. Programming happens via an interface on the back.

PM-TOOL-MUSB4

89,00

• **Technical data**

Dimensions	Housing	B96 x H96 x D56 mm, (incl. plug-in terminal D = 82 mm)
	Panel cut-out	91.0 ^{+0.6} x 91.0 ^{+0.6} mm
	Fixing	screw elements for a wall thickness up to 10 mm
	Housing material	PC Polycarbonate, black
	Sealing material	EPDM, 65 Shore, black
	Protection class	front side IP65 standard, back side IP00
	Weight	approx. 330 g
	Connection	plug-in terminal; cable cross-section up to 2.5 mm ²
Display	Display	5-digit
	Digit height	14 mm
	Segment colour	red (Standard), optional available in green, orange, blue and tricolour, too
	Display range	-19999 up to 99999
	Limit values	optical display flashing
	Overflow	horizontal bars at the top
	Underflow	horizontal bars at the bottom
	Display time	0.1 to 10.0 seconds
	Bargraph	55 dots
	Alignment	270°
Bargraph colour	red	
Measuring input	Signal	Pulse input, TTL, Namur, 3-lead initiator PNP/NPN
	Input resistance	R _i with 24 V / 4 kΩ High/Low level >15 V / < 4 V High/Low TTL-level >4.6 V / <1.9 V
	Input frequency	0.01 Hz selectable up to 999.99 kHz
	Measuring error	0.05% of measuring range; ±1 Digit
Output	Relay	with change-over contact 250 V / 5 AAC, 30 V / 5 ADC
	Switching cycles	30 * 10 ³ at 5 AAC, 5 ADC ohm resistive burden, 10 * 10 ⁶ mechanically Division according to DIN EN50178 / Characteristics according to DIN EN 60255
	Pulse output	max. 10 kHz (only with frequency metering)
	Analog output	0-10 VDC / burden ≥10 kΩ, 0/4-20 mA / burden ≤ 500 Ω, 16 Bit)
Sensor supply	24 VDC / 50mA 10 VDC / 20 mA	
Digital input	Input galv. isolated	< 2.4 V OFF; 10 V ON; max. 30 VDC, R _i ~ 5 kΩ
Interface	Protocol	Modbus with ASCII or RTU-protocol
	RS232	9.600 Baud, no parity, 8 Databit, 1 StopBit; cable length max. 3m
	RS232	9.600 Baud, no parity, 8 Databit, 1 StopBit; cable length max. 1000m
Power pack	Supply	100-240 VAC 50/60 Hz / DC ±10 % (max. 15 VA) 10-40 VDC / 18-30 VAC 50/60 Hz (max. 15 VA)
Memory	EEPROM	Data life ≥ 100 years at 25°C
Ambient conditions	Working temperature	0 to +50°C
	Storing temperature	-20 to +80°C
	Weathering resistance	relative humidity 0-85% on years average without dew
CE-sign	Conformity according to directive 2014/30/EU	
EMV	EN 61326, EN 55011	
Safety standard	According to low voltage directive 2014/35/EU, EN 61010; EN 60664-1	

Housing:

