

PORTABLE TYPE ULTRASONIC FLOWMETER (PORTAFLOW-C)

DATA SHEET

FSC-2, FSS, FSD

PORTAFLOW-C is a portable type ultrasonic flowmeter utilizing the transit time measuring method, using a clamp-on type detector.

It is a compact and lightweight instrument incorporating the latest electronics and digital signal processing technologies, realizing high performance and easy operation.

FEATURES

- 1. Compact and lightweight**
The adoption of the latest electronics and digital signal processing technologies has reduced the size and weight of the flow transmitter by 30% and 30%, respectively, in comparison with the Fuji conventional portable flowmeter (Model FSC). (in comparison to our existing model)
- 2. Battery operation**
The flowmeter is designed for 12 hours of continuous operation via built-in battery which is rechargeable in 3 hours with the exclusive power adapter.
- 3. Full variety of detectors**
The flowmeter is suitable for various types of detectors applicable for small to large diameter pipe (pipe inner diameter $\phi 13$ to $\phi 6000\text{mm}$) and low to high temperature (-40 to $+200^\circ\text{C}$).
- 4. High accuracy and high-speed response**
The flowmeter is designed for high accuracy ($\pm 1.0\%$).
Response time is within 1 second.
- 5. Improved anti-bubble characteristic**
Anti-bubble characteristic is greatly improved by digital signal processing.
- 6. Excellent performance and easy operation**
Large graphic LCD that is outside but easy to read. Minimum number of function keys are used for page selection, allowing easy setting.
While battery is working, the flowmeter is water resistant and tolerates exposure to rain.
- 7. Large capacity storage by SD memory card**
Measured data is periodically stored in SD memory card. For example, in the case of 512MB (option), it can be saved about 2 year measurement date (in case of saving period 30 seconds, 14 kinds of saved data). Available up to 8MB.
- 8. Serial communication**
Use of a USB port allows easy connection to a personal computer. Measured data collection panel and Loader software for PC (standard) which is available for display and change of parameter (site setting) are prepared.
- 9. Heat quantity (calorie) measurement**
Heat quantity (calorie) may be measured by temperature input, making energy management easy for cooling and heating.



Flow transmitter (FSC)



Detector (FSSC)

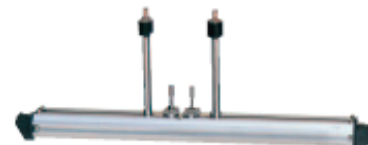

Detector for high-temperature (FSSH)

- 10. Graphic printer connection (option)**
Easy recording with the Integral type printer.
- 11. Flow velocity profile measurement (option)**
Flow profile may be observed in real time.

SPECIFICATIONS

Measuring objects

Measurement fluid:

Uniform liquid in which ultrasonic waves can propagate.

Turbidity of fluid: 10000 mg/L or less

State of fluid: Well-developed turbulent or laminar flow in a filled pipe.

Fluid temperature: -40 to $+200^\circ\text{C}$

Measuring range: $0 \dots \pm 0.3$ to $\pm 32\text{m/s}$

Piping conditions

Applicable piping material:

Select from carbon steel, stainless steel, cast iron, PVC, FRP, copper, aluminum, acrylic or material of known sound velocity.

Pipe size:

Flow rate measurement
 $\phi 13$ to $\phi 6000\text{mm}$

Flow velocity profile measurement
 $\phi 40$ to $\phi 1000\text{mm}$

Lining material: Select from no lining, tar epoxy, mortar, rubber, Teflon, pyrex glass or material of known sound velocity.
 Note) No gap allowed between the lining and the pipe.

Straight pipe length:
 10D or more upstream and 5D or more downstream (D: internal pipe diameter)
 Refer to Japan Electric Measuring Instruments Manufacturers' Association's standard JEMIS-032 for details.

Performance specifications

Accuracy rating:

| Pipe inner diameter | Flow velocity range | Accuracy |
|---------------------|---------------------|-----------------------|
| ø13 to ø50mm | 2 to 32m/s | ±1.5% of rate |
| | 0 to 2m/s | ±0.03m/s |
| ø50 to ø300mm | 2 to 32m/s | ±1.0% to 1.5% of rate |
| | 0 to 2m/s | ±0.02 to 0.03m/s |
| ø300 to ø6000mm | 1 to 32m/s | ±1.0% to 1.5% of rate |
| | 0 to 1m/s | ±0.01 to 0.02m/s |

Note1) Reference conditions are based on JEMIS-032.
 Note2) Refer to the 4 pages for the accuracy according to kind of detector.

Flow transmitter (Type: FSC)

Power supply: Built-in battery or AC power adapter
 Built-in battery: Exclusive lithium button battery (5000m Ah)
 Continuous operation time, approx. 12 hours (without printer, back light OFF, output current not used and at normal ambient temperature (20°C))
 Recharging time, approx. 3 hours (power adapter used)
 Recharging temperature range: 0 to +40°C
 Power consumption: Min. 3W and Max. 16W
 The consumption varies depending on the use conditions.
 Power adapter: Exclusive power adapter 100V to 240V +10%/–15% AC (50/60Hz), 70VA or less.

LCD: Semi-transmissive color graphic display 240 × 320 (with back light)
 Measurement value (instantaneous flow rate, integrated flow rate) and various settings are displayed.
 Excellent visibility even outdoors in direct sunlight.

LED display: Status display when using AC power adapter.
 DC IN (green): Power supply status
 CHARGE (red): Battery charging underway

Operation keypad:
 11 buttons
 (ON, OFF, ENT, ESC, MENU, Δ, ▽, <, >, LIGHT, PRINT)

Power failure backup:
 Measurement value is backed up by nonvolatile memory.
 Clock backup with lithium battery (effective term, 10 years or more)

Response time: 1 second

Analog output signals:
 4 to 20mA DC, one point (load resistance, 600Ω or less)
 Instantaneous velocity, instantaneous flow rate or heat quantity (calorie) after scaling.

Analog input signal:
 4 to 20mA DC, one point (input resistance, 200Ω or less)
 4 to 20mA DC, one point (input resistance, 200Ω or less) or 1 to 5V DC, one point
 Used to input temperature for heat quantity measurement, etc.

} Total 2 points

SD memory card: Used for data logger function and recording screen data.
 Available up to 8GB (Option256MB)
 Compliant media

- SD memory card: speed class 2, 4, 6
- SDHC memory card: speed class 4, 6

Format

- FAT16: 64MB to 2GB
- FAT32: 4GB, 8GB

Otherwise, reading and saving are impossible.
 File format

- Date logger: CSV file
- Screen date: Bit map file

Serial communication:
 USB port (device* compatible):
 Mini B receptacle
 Connectable number of Mini B receptacles:
 1 unit
 Transmission distance: 3m max.
 Transmission speed: 500kbps
 Data:
 Instantaneous velocity, instantaneous flow rate, total value, heat quantity (calorie) value, error information, logger data, etc.
 * Device: Connected plug from PC

Printer (option): To be mounted on top of transmitter unit
 Thermal line dot printing
 Note) When the Chinese display is selected, printing is made in kanji characters.

Ambient temperature:
 –10 to +55°C (Without printer)
 –10 to +45°C (With printer)

Ambient humidity: 90%RH or less
Type of enclosure: IP64 (Without printer)
Enclosure case: Plastic case
Outer dimensions: H210 × W120 × D65mm (Without printer)
 H320 × W120 × D65mm (With printer)
Weight: 1.0kg (Without printer)
 1.2kg (With printer)

Various functions

Display language: Selectable from Japanese, English, German, French, Spanish or Chinese (switchable by key operation).

Clock display function:
 Time (year, month, day, hour, minute) display (configurable)
 Monthly error: about 1 minutes at normal temperature (20°C).

Instantaneous value display function:

Instantaneous velocity, instantaneous flow rate display (The flow in reverse direction is displayed with minus "-.")
 Numeric value: 10 digits (decimal point equals 1 digit)
 Unit: Metric/English system selectable
 Metric system
 Velocity: m/s
 Flow rate: L/s, L/min, L/h, L/d, kL/d, ML/d, m³/s, m³/min, m³/h, m³/d, km³/d, Mm³/d, BBL/s, BBL/min, BBL/h, BBL/d, kBBL/d, MBBL/d
 English system
 Velocity: ft/s
 Flow rate: gal/s, gal/min, gal/h, gal/d, kgal/d, Mgal/d, ft³/s, ft³/min, ft³/h, ft³/d, kft³/d, Mft³/d, BBL/s, BBL/min, BBL/h, BBL/d, kBBL/d, MBBL/d

Total value display function:

Display of forward or reverse total (reverse is displayed as minus)
 Numeric value: 10 digits (decimal point is corresponding to 1 digit)
 Unit: Metric/English system selectable
 Metric system
 Flow rate total: mL, L, m³, km³, Mm³, mBBL, BBL, kBBL
 English system
 Flow rate total: gal, kgal, ft³, kft³, Mft³, mBBL, BBL, kBBL, ACRE-ft

Consumed heat quantity (calorie) display function:

Display of consumed heating medium
 Metric system
 Heat flow: MJ/h, GJ/h
 Total heat quantity: MJ, GJ
 English system
 Heat flow: MJ/h, GJ/h, BTU/h, kBTU/h, MBTU/h, kW, MW
 Total heat quantity:
 MJ, GJ, BTU, kBTU, MBTU, kWh, MWh
 J : Joule
 BTU : British thermal unit
 W : Watt

Computation function of consumed heat quantity (calorie):

This function calculates the heat quantity received and sent with liquid (water) in cooling and heating.

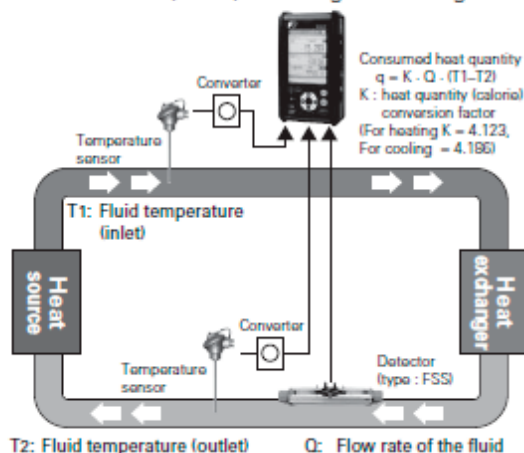

Temperature display function:

Fluid temperature be displayed by current input from temperature transmitter.
 Metric system
 Temperature unit: °C or K
 English system
 Temperature unit: F or K

Site data storage function:

Max. 32 locations (sites) data (pipe size, material, fluid type and etc) can be stored into built-in non-volatile memory.

Damping: 0 to 100sec (every 0.1sec) configurable for analog output and velocity/flow rate display

Low flow cut: Equivalent to 0 to 5m/s

Output setting function:

Current output scaling, output type, burnout setting and calibration

Serial communication function:

Instantaneous velocity, instantaneous flow rate, total value, heat flow, error information, received waveform, analog input, velocity profile data, logger data, etc. may be downloaded to personal computer.

Logger function: Instantaneous velocity, instantaneous flow rate, total value, heat flow, error information, received waveform, analog input, velocity profile data can be saved in a SD memory card.

Waveform display function:

Bi-directional received waveforms may be displayed.

Graph display function:

Flow rate trend graph may be displayed.

Printing function (option):

Hard copy output of a screen
 Periodic printing (type: text, graph)
 Logger data (type: text, graph)

Flow velocity profile measurement (option):

Flow velocity profile may be observed in real time using the exclusive detector (option).
 (Refer to page 5 for details.)

Detector (Type: FSS)

Type of detector:

| Classification | Type | Internal pipe diameter (mm) | Fluid temperature |
|------------------|------|-----------------------------|-------------------|
| Middle diameter | FSSC | ø50 to ø1200 | -40 to 120°C |
| Small diameter | FSSD | ø13 to ø300 | -40 to 100°C |
| Large diameter | FSSE | ø200 to ø6000 | -40 to 80°C |
| High temperature | FSSH | ø50 to ø400 | -40 to 200°C |

Mounting method: Mounting on outside of pipe

Sensor mounting method:

V or Z method

Signal cable: Exclusive coaxial cable, 5m (Included with FSC)

Connection method:

Transmitter side
 Exclusive connector
 Detector side (FSSE)
 Screw terminal
 Others: BNC connector

Ambient temperature:

-20 to +60°C

Ambient humidity:

FSSE 100%RH or less
Other 90%RH or less

Type of enclosure:

FSSC IP65
(When waterproof BNC connector is provided)
FSSE IP67
Others IP52
Water-proof treatment type IP68
(Submerged resistant structure for 5 days)

Material of detector:

| Classification | Type | Sensor case | Rail material |
|------------------|------|-------------|--------------------------|
| Small diameter | FSSD | Plastic | Aluminum alloy + Plastic |
| Middle diameter | FSSC | Plastic | Aluminum alloy + Plastic |
| Large diameter | FSSE | Plastic | — |
| High temperature | FSSH | SUS304 | Aluminum alloy |

Material of mounting belt/wire:

| Detector type 6th digit | Dimensions | Material |
|-------------------------|--|--------------------|
| A | 1.5mX2 | SUS304 |
| B | 3.0mX1 | Plastic cloth belt |
| C | 1.0mX4 | SUS304 |
| D | Inner pipe diam. $\phi 1500\text{mm}$ | SUS304 |
| E | Inner pipe diam. $\phi 6000\text{mm}$ | SUS304 |

Extension cable(option):

Extended when the length of the detector signal cable is not sufficient.
Length: 10m, 50m

MEASURING PRINCIPLE

With ultrasonic pulses propagated diagonally between the upstream and downstream sensors, flow rate is measured by detecting the time difference obtained by the flow of fluid.

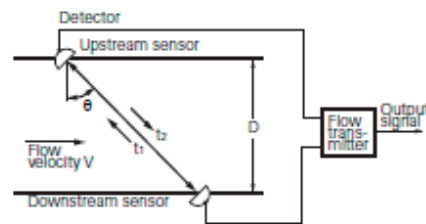

MOUNTING OF DETECTOR

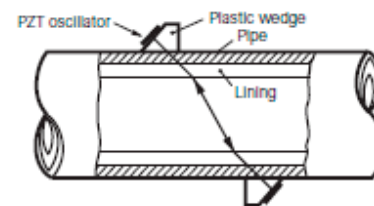

CONFIGURATION DIAGRAM

(1) When V method is used for mounting

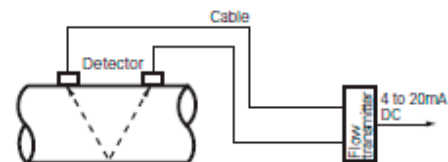

(2) When Z method is used for mounting

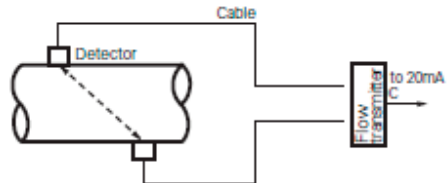

DETECTOR SELECTION GUIDE (ACCURACY % of rate)

| TYPE | Mounting method | Inner diameter of piping ϕ [mm] | | | | | | | | | | | | | | |
|------|------------------|--------------------------------------|----|------|------|------|-----|---------|---------|---------|---------|------|---------|------|--|--|
| | | 13 | 25 | 50 | 100 | 150 | 200 | 250 | 300 | 400 | 600 | 1200 | 3000 | 6000 | | |
| FSSD | V ^{*2)} | ±1.5 to 2.5 | | ±1.0 | | | | Hatched | | | | | | | | |
| | Z ^{*1)} | Hatched | | | | ±1.0 | | | | Hatched | | | | | | |
| FSSC | V | Hatched | | | ±1.5 | | | ±1.0 | | | Hatched | | | | | |
| | Z | Hatched | | | | | | ±1.0 | | | | | Hatched | | | |
| FSSE | V | Hatched | | | | | | ±1.5 | | | ±1.0 | | Hatched | | | |
| | Z | Hatched | | | | | | ±1.5 | | | | | ±1.0 | | | |
| FSSH | V | Hatched | | | ±1.0 | | | | Hatched | | | | | | | |
| | Z ^{*1)} | Hatched | | | | ±1.0 | | | | Hatched | | | | | | |

*1) When FSSD or FSSH is mounted using the Z method, guide rail (option) is required additionally.

*2) For the pipe inner diameter of $\phi 13\text{mm}$, the sensor mounting dimension may be 0.0mm or less depending on pipe material and thickness. When the sensor mounting dimension is 0.0mm or less, measurement error is about 2 to 5%.

<Description of the table>

It shows pipe thickness of each material that the sensor mounting size is to be 0.0mm, when fixing a pipe. If the fluid is the one other than water, and if the sound velocity of fluid is faster than the one of water, the sensor mounting size is to be 0.0mm or more.

| Required min. pipe thickness (fluid: water) (Unit: mm) | | | |
|--|--------------|-------------------|--------------|
| Steel pipe | 2.15 or more | FRP | 3.21 or more |
| Stainless pipe | 1.87 or more | Ductile cast iron | 2.15 or more |
| PVC pipe | 3.69 or more | PEEK | 3.69 or more |
| Copper pipe | 3.82 or more | PVDF | 3.69 or more |
| Cast-iron pipe | 2.98 or more | Acrylic pipe | 2.90 or more |
| Aluminum pipe | 1.99 or more | Polypropylene | 3.69 or more |

FLOW VELOCITY PROFILE DISPLAY FUNCTION (OPTION)

Flow velocity profile can be observed in real time using the dedicated detector from the outside. It is specifiable by the code symbol of flow transmitter.

APPLICATION

Pulse Doppler method is applicable to observe flow velocity profile in real time, display the flow status in the pipe, and decide the appropriate measurement location. Also, it can be used for diagnosis of flow and laboratory test.

SPECIFICATIONS

- Measuring fluid: Uniform liquid in which ultrasonic waves can propagate.
- Turbidity of fluid: Axisymmetric flow in a filled pipe.
- Fluid temperature:
 - 40 to +100°C (FSDP2)
 - 40 to +80°C (FSDP1, FSDP0)
- Air bubble quantity: 0.02 to 15Vol% (Velocity is 1m/s)
- Pipe size:
 - Small type sensor : $\phi 40$ to $\phi 200$ mm
 - Middle type sensor : $\phi 100$ to $\phi 400$ mm
 - Large type sensor : $\phi 200$ to $\phi 1000$ mm
- Measurement range:
 - 0 to ± 0.3 : \pm Maximum Velocity (depending on the pipe diameter)
 - Refer to chart, table.1.
 - Note) This function is to observe flow velocity profile, and it may be different from actual flow rate.

DETECTOR FOR FLOW VELOCITY PROFILE MEASUREMENT (TYPE: FSDP)

- Mounting method: Mounting on outside of existing pipe
- Ambient temperature: -20 to +80°C
- Ambient humidity: 100% RH or less
- Type of enclosure: IP67 (with waterproof BNC connector provided.)
- Material:
 - Sensor housing: PBT
 - Guide frame: Aluminum alloy
 - Mounting belt: Plastic cloth belt/stainless belt

MEASUREMENT PRINCIPLE

<Pulse Doppler method>

- Ultrasonic pulses are transmitted through the fluid flow. Entrained bubbles and microscopic particles within the fluid create frequency phase shifts (Doppler effect.) The resulting doppler shifts are integrated across the inside pipe diameter cross section. The resulting profile curve is a real-time dynamic display of the flow profile within the pipe.

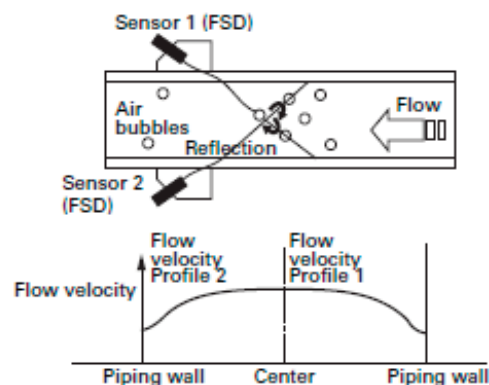

The above shows an example when using two sensors. One detector displays the flow velocity profile for a radius.

BLOCK DIAGRAM

(1) Using one sensor

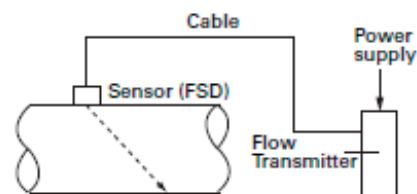

(2) Using two sensors

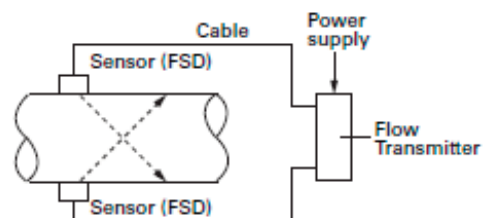

Table.1

Maximum measurement range of Pulsed Doppler method.
When nominal thickness of a stainless pipe of pipe material is Sch20s and the fluid is water, the maximum measurement range varies depending on the outer diameter of pipe, nominal thickness, material, or fluid type.

| Diameter | <Maximum measurable flow velocity> Unit: m/s | | | <Maximum measurable flow rate> Unit: m ³ /h | | |
|----------|---|-------|-------|---|-------|-------|
| | FSDP2 | FSDP1 | FSDP0 | FSDP2 | FSDP1 | FSDP0 |
| 40A | 6.56 | | | 33.6 | | |
| 50A | 6.52 | | | 52.7 | | |
| 65A | 5.31 | | | 72.1 | | |
| 80A | 4.65 | | | 86.5 | | |
| 90A | 4.12 | | | 102 | | |
| 100A | 3.69 | 7.25 | | 118 | 231 | |
| 125A | 3.08 | 6.08 | | 147 | 289 | |
| 150A | 2.63 | 5.20 | | 179 | 354 | |
| 200A | 2.04 | 4.05 | 7.77 | 239 | 474 | 908 |
| 250A | | 3.30 | 6.38 | | 604 | 1168 |
| 300A | | 2.78 | 5.41 | | 735 | 1428 |
| 350A | | 2.51 | 4.90 | | 820 | 1598 |
| 400A | | 2.20 | 4.31 | | 951 | 1858 |
| 450A | | | 3.80 | | | 2118 |
| 500A | | | 3.48 | | | 2358 |
| 550A | | | 3.17 | | | 2618 |
| 600A | | | 2.91 | | | 2879 |
| 650A | | | 2.71 | | | 3096 |
| 700A | | | 2.52 | | | 3357 |
| 750A | | | 2.35 | | | 3618 |
| 800A | | | 2.21 | | | 3879 |
| 850A | | | 2.08 | | | 4140 |
| 900A | | | 1.97 | | | 4400 |
| 1000A | | | 1.77 | | | 4902 |

PC Loader software

Equipped as standard

- PC/AT compatible machines. (Operation on custom built PCs or shop-brand PCs cannot be guaranteed.)
- Major functions: Performs parameter (site setting) display /change of the main unit and collects measured data.

Instantaneous velocity, instantaneous flow rate, total value, error information, received waveform, analog input, logger data, etc. may be downloaded in a personal computer.

- O/S: Windows2000/XP/Vista* or Windows 7 (Home Premium, Professional)
- Memory requirement: 128MB or more
- Disk unit: Windows2000/XP/Vista or Windows 7 (Home Premium, Professional)-compatible CD-ROM drive
- Hard disk drive capacity: Free space of 64MB or more

* Windows Vista: Use it in basic mode.
It is not available for Windows Aero.

CODE SYMBOL

<Flow transmitter>

| 1 | 2 | 3 | 4 | 5 | 6 | 7 | 8 | 9 | 10 | 11 | Description |
|---|---|---|---|---|---|---|---|---|----|----|---|
| F | S | C | | | | | | 2 | - | 0 | <Specification> Standard |
| | S | | | | | | | | | | <Converter> Basic system Basic system + Printer |
| | 1 | | | | | | | | | | <Flow velocity profile measurement> None Provided (detector to measure flow velocity profile is separately required.) |
| | 2 | | | | | | | | | | <Power adapter> AC power + power cord (125V AC) for Japanese and North American use AC power + power cord (250V AC) for European and Korean use AC power + power cord (250V AC) for Chinese use |
| | A | | | | | | | | | | Modification No. |
| | B | | | | | | | | | | |
| | C | | | | | | | | | | <SD memory card> None Provided (512MB) |
| | | | | | | | | 2 | | | <Bound instruction manual/Language> None (Factory-set language: English) Provided/Japanese (Factory-set language: Japanese) Provided/English (Factory-set language: English) Provided/Chinese (Factory-set language: Chinese) (Note1) Instruction manual contained in CD is the standard attached article. (Note2) You can change the language by key operation. |
| | | | | | | | | 0 | | | |
| | | | | | | | | 1 | | | |
| | | | | | | | | | | | |

<Detector>

(for transit time)

| 1 | 2 | 3 | 4 | 5 | 6 | 7 | 8 | 9 | 10 | Description |
|---|---|---|---|---|---|---|---|---|----|--|
| F | S | S | C | 1 | | | | | | <Sensor type>-(4th digits) ø50 to ø1200mm |
| | | | C | | | | | | | <Guide rail>-(5th digits) Provided (Extendable rail type) |
| | | | 1 | | | | | | | <Mounting belt>-(6th digits) *2 None Stainless belt (1.0m×2) Plastic cloth belt (3m×1) SS belt fasten with screws (1.0m×4) Wire ø1500mm |
| | | | Y | | | | | | | <Acoustic coupler>-(7th digit) *1 None Silicone-free grease (HIGH-Z) Silicone grease (G40M) |
| | | | A | | | | | | | |
| | | | B | | | | | | | |
| | | | C | | | | | | | <Water-proof treatment>-(9th digit) None Provided (with signal cable 10m) *Submersible in water for 5 days |
| | | | | | | | | Y | | <Tag plate>-(10th digit) None Provided |
| | | | | | | | | A | | |

*1: Normally select silicone grease as acoustic coupler. Silicone grease is tube (100g).
Select silicone-free grease for semiconductor manufacturing equipment or the like that is vulnerable to silicone. The silicone-free grease is water-soluble and, therefore, cannot be used in environment exposed to water or on piping subjected to a condensation. Since the grease does not set, a periodic maintenance (cleaning, refilling every about 6 months at normal temperature) is necessary.

*2: Please refer to the table 1 to select the mounting belt at 6th digits.

[Table 1] How to select at 6th digits.

| Mounting method | ø300mm | ø600mm | ø1200mm |
|-----------------|-----------|--------|---------|
| V method | B, A or C | C | D |
| Z method | C | D | D |

CODE SYMBOL

<Detector>

(for flow velocity profile measurement)

| 1 | 2 | 3 | 4 | 5 | 6 | 7 | 8 | Description |
|---|---|---|---|---|---|-----|---|-------------|
| F | S | D | | | | 0 | Y | 1 |
| | | | | | | P 2 | | |
| | | | | | | P 1 | | |
| | | | | | | P 0 | | |
| | | | | | | 0 | | |
| | | | | | | Y | | |
| | | | | | | 1 | | |

SCOPE OF DELIVERY

<Flow transmitter : FSC>

| Name of unit | Scope of delivery |
|----------------|--|
| 1 Basic system | 1) Conversion unit 2) Power adapter and Power connector conversion cord 3) Power cord 4) Analog input/output cord (1.5m) 5) USB cable (1m) 6) Carrying case 7) Strap 8) Special type signal cable (5m x 2) 9) CD-ROM (Instruction manual and Loader software for PC) |
| 2 Option | 1) Printer unit + rolled paper (1 roll) 2) SD memory card (512MB) 3) Bound instruction manual (including a detector) |

<Detector : FSS, FSD>

| Name of unit | Scope of delivery |
|--|---|
| 1 Detector for propagation time difference (FSS) | 1) Sensor unit 2) Signal cable conversion code (included with FSSE) 3) Mounting belt/wire 4) Silicone grease (Article specified) |
| 2 Detector for flow velocity profile (FSDP) | 1) Detector unit 2) Mounting belt/wire 3) Silicone grease (100g) |

Note 1) Silicon grease is for filling a gap between a detector and a pipe joint area. It is provided with a detector. Since silicon grease does not become hardened, if you use it in the long term, periodic maintenance is required. (Under the condition of room temperature, semiannual cleaning and refill is recommended.)

Note 2) When you order a detector alone, an instruction manual is not provided. Please request, if necessary (Onerous).

OPTIONAL ITEMS

| | Name | Specifications | Arrangement No. |
|----|--|--|--|
| 1 | Battery | Special type Li-ion battery (7.4V, 2500mAh) | ZZP*TK7N6384P1 *Order in two pairs. |
| 2 | AC power adapter | Special type power adapter and 100 to 240V +10%/-15% AC, 50/60Hz | ZZP*TK7N6380C4 |
| 3 | Power code | Japan, North America: 125V AC 2m Europe, Korea: 250V AC 2m China: 250V AC 2m | ZZP*TK7N6621P1 ZZP*TK7N6608P1 ZZP*TK7N6609P1 |
| 4 | Printer | To be mounted on top of converter Thermal serial dot system (8 x 384 dot) | ZZP*TK4J2634C1 |
| 5 | Printer roll paper | Maker: SEIKO I SUPPLY Co. Ltd. Type: TP-211C-1 Specifications: Thermal roll paper Width: 58mm x ø48mm | ZZP*TK7N6381P1 |
| 6 | Silicone grease | Maker: Shin-Etsu Chemical Co., Ltd. Type: - For standard use G40M, 100g - For silicone free 100g - For high temperature KS62M, 100g | ZZP*45231N5 ZZP*TK7M0981P1 ZZP*TK7P1921C1 |
| 7 | Signal cable | Special type signal cable, 5m x 2 (connector on both - sides) | ZZP*TK7N7795C1 |
| 8 | Extension signal cable | Special type coaxial cable with BNC connector - 10m x 2 - 50m x 2 | ZZP*TK468664C3 ZZP*TK468664C4 |
| 9 | Analog input/output cable | 6-core cable, 1.5m, with connector | ZZP*TK4J2639C1 |
| 10 | Mounting belt/wire | - Plastic cloth belt - Stainless wire Nominal diameter ø200 to ø500mm ø200 to ø1000mm ø200 to ø2000mm ø200 to ø3000mm ø200 to ø6000mm - Stainless steel belt | ZZP*TK7G7979C1 ZZP*TK7G7980C1 ZZP*TK7G7980C2 ZZP*TK7G7980C3 ZZP*TK7G7980C4 ZZP*TK7G7980C5 ZZP*TK7P1943C1 |
| 11 | Guide rail for high-temperature sensor (In mounting by the Z method) | - Mounting bracket material: Aluminum alloy+SUS304 For FSSH | ZZP*TK4J5917C3 |
| 12 | Guide rail for small type detector (In mounting by the Z method) | - Mounting bracket material: Aluminum alloy+plastic For FSSD3 (L=540mm) | ZZP*TK4J5917C1 |
| 13 | SD memory card | Maker: Panasonic, Inc. Type: RP-SDFC51CD1 Capacity: 512MB | ZZP*TK7N7680P1 |
| 14 | USB cable | Maker: Sunwa Supply Inc. Type: KU-AMB510 Specifications: Mini USB cable (1.0m) | ZZP*TK7N6622P1 |
| 15 | Signal cable conversion cord | M4 clamp terminal / BNC jack, L=150mm | ZZP*TK4K6304P1 |

Diagram

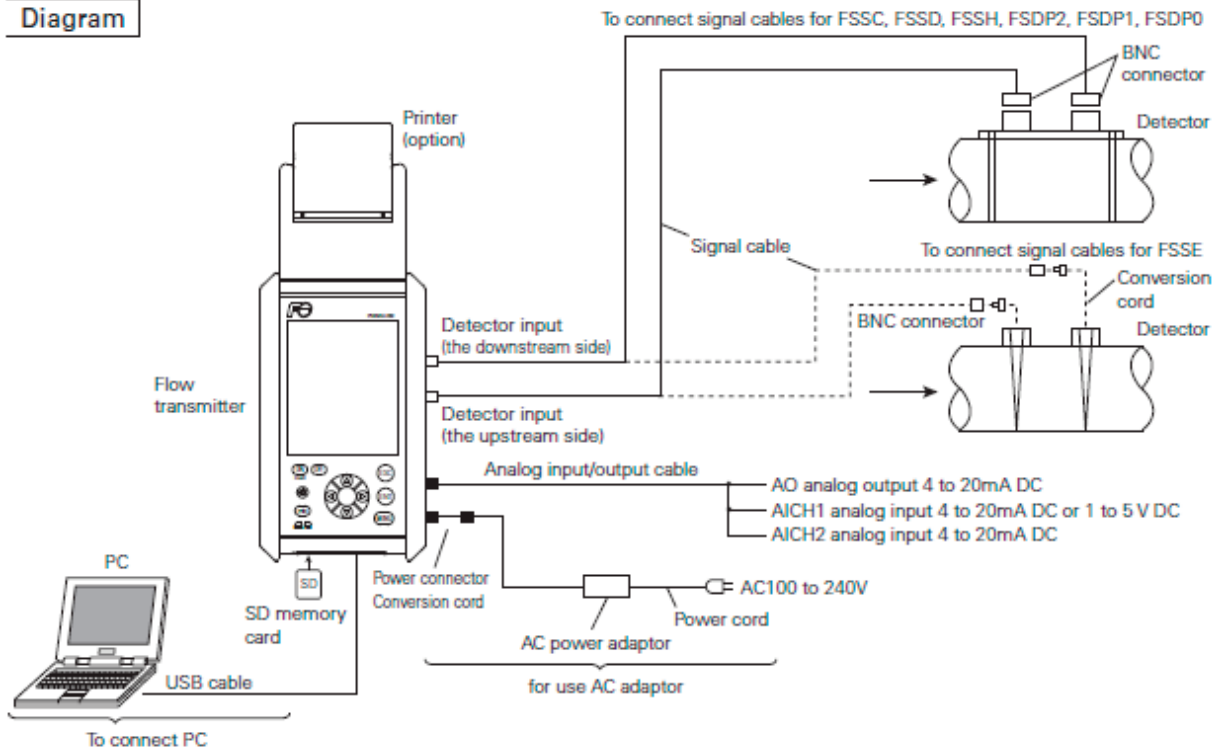

Conditions on straight pipe

(D: Nominal diameter of pipe)

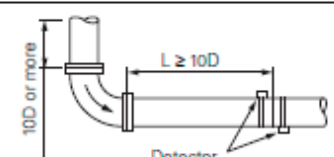
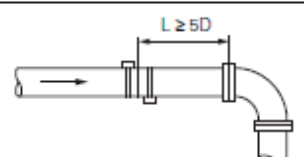
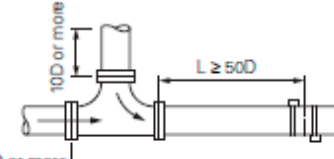
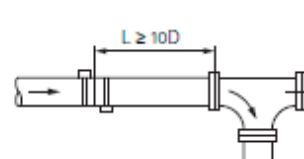
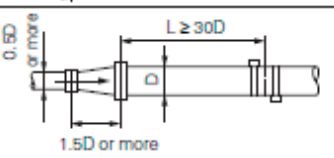
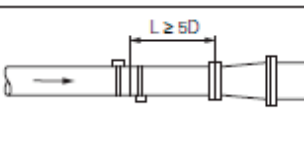
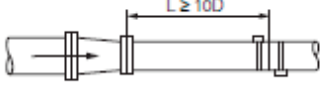
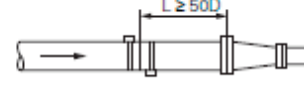
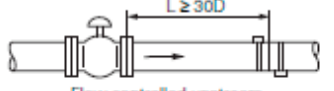
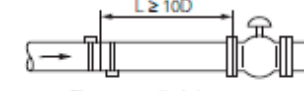
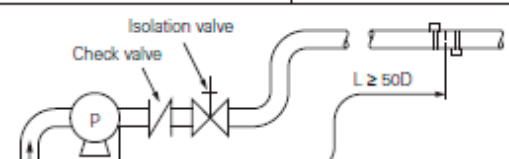
| Type | Length of upstream straight pipe | Length of downstream straight pipe |
|------------------|--|--|
| 90° bend |  |  |
| Tee |  |  |
| Diffuser |  |  |
| Contraction pipe |  |  |
| Valve |  |  |
| Pump |  | |

Note! Source: Japan Electric Measuring Instruments Manufacturers' Association (JEMIS-032)

OUTLINE DIAGRAM (Unit:mm)

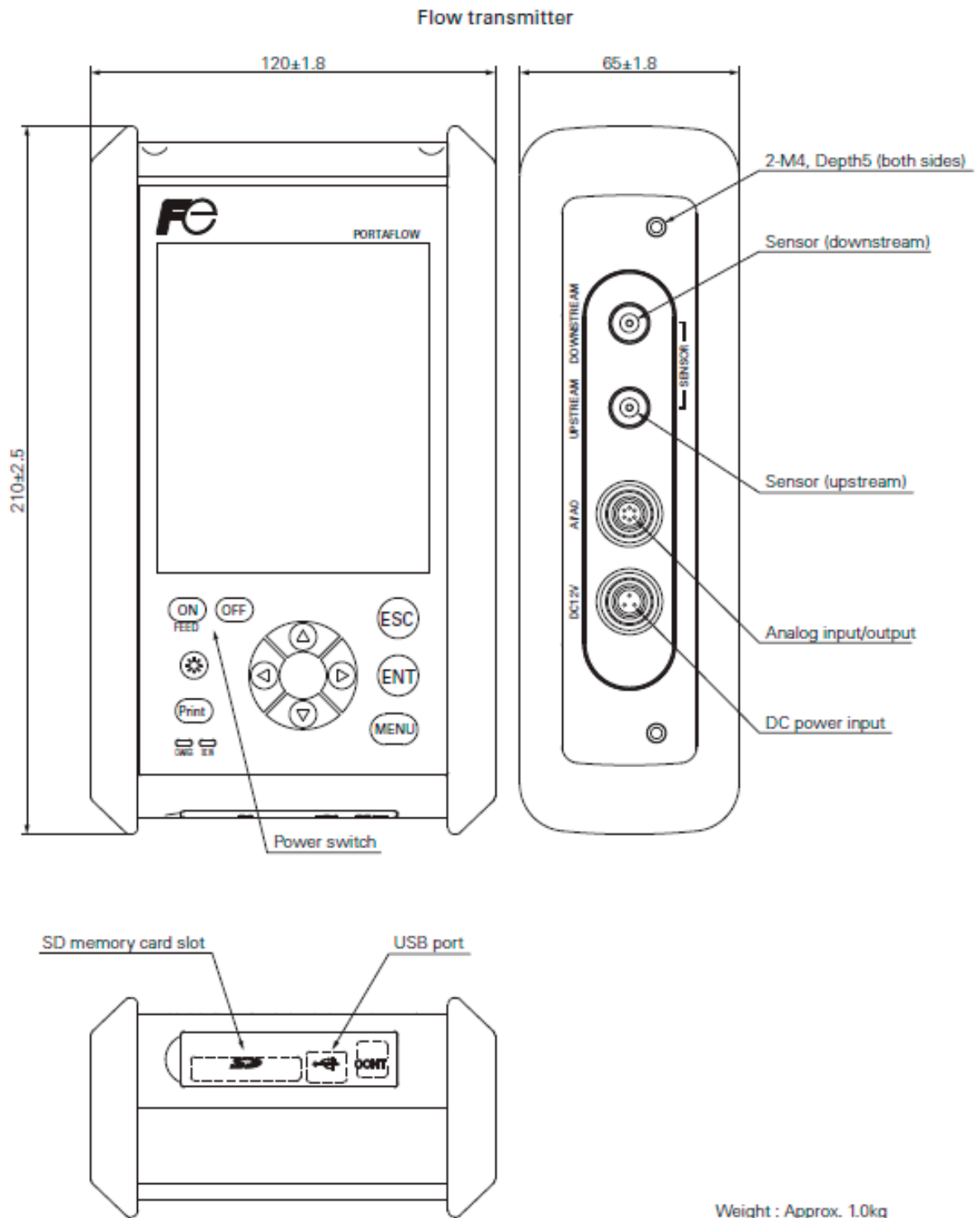

OUTLINE DIAGRAM (Unit:mm)

Flow transmitter (with printer)

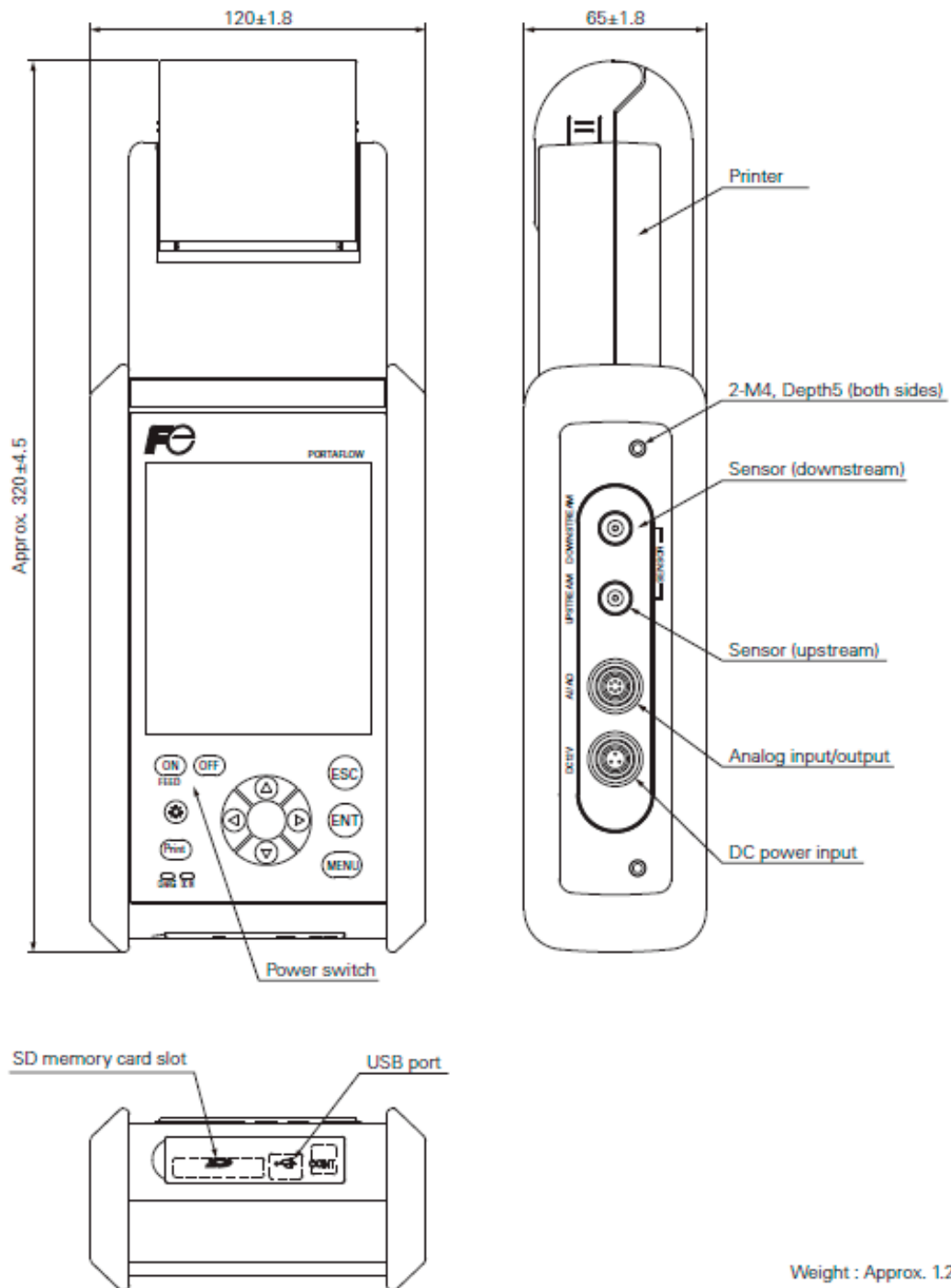

Weight : Approx. 1.2kg

OUTLINE DIAGRAM (Unit:mm)

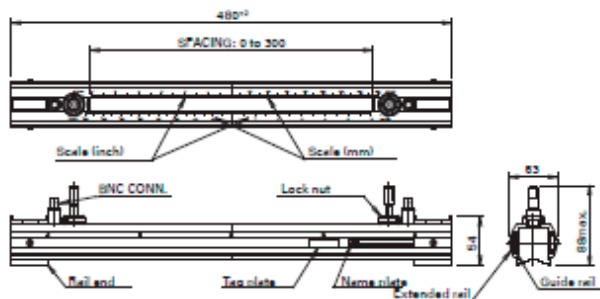

<Shipment style (V method)>

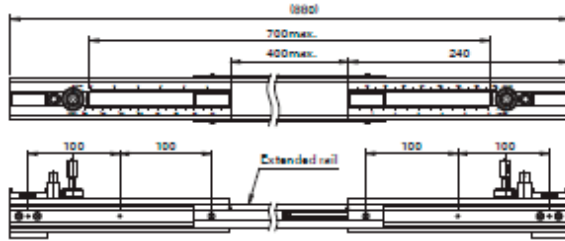

<Extended style (Longest, V method)>



<Separate style (Z method)>

Detector : Type FSSC

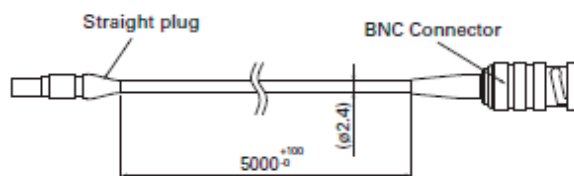
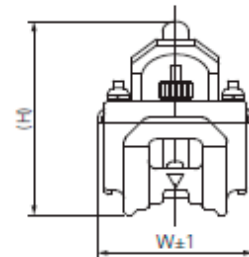
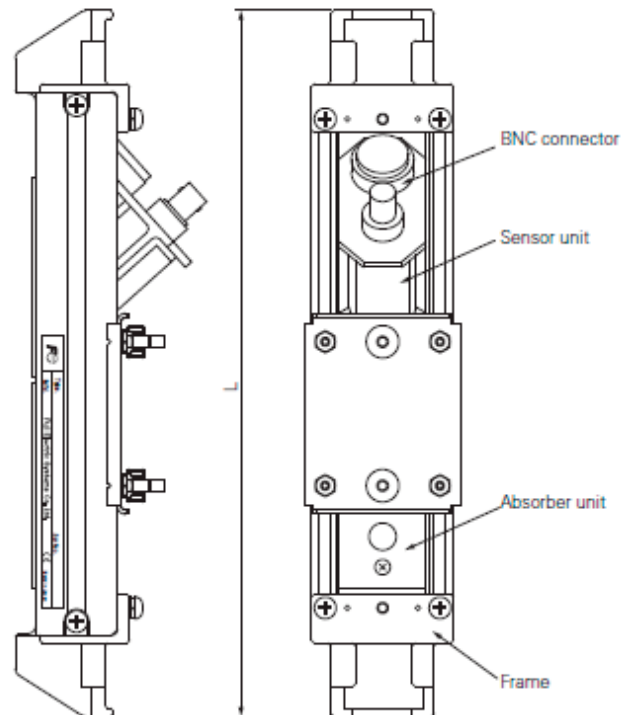

Signal cable

| Type | Diameter (mm) | L | H | W | Weight Approx. (kg) |
|-------|-----------------|---------|----|----|---------------------|
| FSDP2 | φ 40 to φ 200 | 260±1.2 | 70 | 57 | 0.8 |
| FSDP1 | φ 100 to φ 400 | 260±1.2 | 72 | 57 | 0.9 |
| FSDP0 | φ 200 to φ 1000 | 350±2.0 | 90 | 85 | 2.0 |

Detector FSDP (Detector for flow velocity profile measurement)

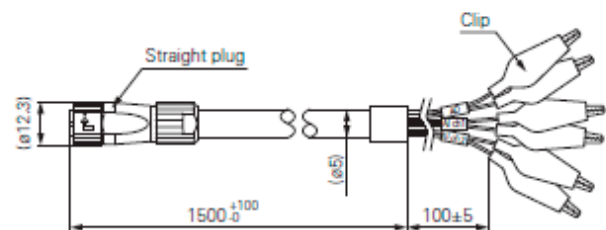

Weight : approx. 0.1kg

| Code color | Clip color | Mark |
|------------|----------------|--------|
| Black (BK) | Red (R) (+) | AO |
| White (W) | Black (BK) (-) | |
| Red (R) | Red (R) (+) | AI ch1 |
| Green (G) | Black (BK) (-) | AI ch2 |
| Yellow (Y) | Red (R) (+) | |
| Brown (BN) | Black (BK) (-) | |

Analog input/output cable

Detector for special application 1) detector for small diameter type

Pipe size: $\varnothing 13$ to 100mm (300mm max.)

Fluid temperature: -40 to 100°C

Type: FSSD□□□□1-Y□

Specification

- Sensor frequency: 2MHz
- Mounting method: V method, Z method (FSSD3)
- Fluid temperature: -40 to 100°C
- Applicable pipe material: PVC, SS, carbon steel pipe, copper pipe, aluminum pipe, etc.

[In case lining is removed from the pipe, Measurement can not be conducted]

- Rated accuracy of combination with the flow transmitter (Applicable piping: plastic, metal pipe)

| Internal diameter (mm) | Velocity | Accuracy |
|--|------------|------------------------------------|
| $\varnothing 13$ to $\varnothing 50$ | 2 to 32m/s | $\pm 1.5\%$ to $\pm 2.5\%$ of rate |
| | 0 to 2m/s | ± 0.03 to $\pm 0.05\text{m/s}$ |
| $\varnothing 50$ to $\varnothing 100$ ($\varnothing 300$) | 2 to 32m/s | $\pm 1.0\%$ of rate |
| | 0 to 2m/s | $\pm 0.02\text{m/s}$ |

- Mounting belt: according to specified code of symbol.
- Material: PBT, guide rail: aluminum alloy + plastic
- Type of enclosure: IP52
- Acoustic coupler: according to specified code of symbol.
- Mass: 0.6kg, 0.8kg

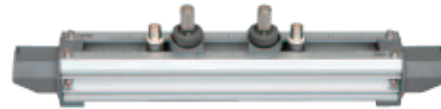

CODE SYMBOL

<Detector>

| 1 | 2 | 3 | 4 | 5 | 6 | 7 | 8 | 9 | 10 | Description |
|---|---|---|---|---|---|---|---|---|----|---|
| F | S | S | D | 1 | 1 | | | | | <Sensor type>(4th digits) $\varnothing 13$ to $\varnothing 100\text{mm}$ |
| | | | | | | | | | | <Guide rail>(5th digits) Provided (L=320mm) $\varnothing 100\text{mm}$ long rail (L=540mm) $\varnothing 300\text{mm}$ |
| | | | | | | | | | | <Mounting belt>(6th digits) None Stainless belt (1.5m \times 2) Plastic cloth belt (3m \times 1) SS belt fasten with screws (1.0m \times 4) |
| | | | | | | | | | | <Acoustic coupler> (7th digit) None Silicon rubber (KE348) Silicone-free grease (HIGH-Z) Silicone grease (GM40M) |
| | | | | | | | | | | <Water-proof treatment>(9th digit) None |
| | | | | | | | | | | <Tag plate> (10th digit) None Provided |

OPTIONAL ACCESSORIES

| Name | Drawing No. |
|-------------------------------|----------------|
| Silicon grease (GM40M) | ZZP*45231N5 |
| Silicone-free grease (HIGH-Z) | ZZP*TK7M0981P1 |

Scope of delivery

- Detector, acoustic coupler and set of the mounting belt according to specified code of symbol

OUTLINE DIAGRAM (unit: mm)

<Detector>

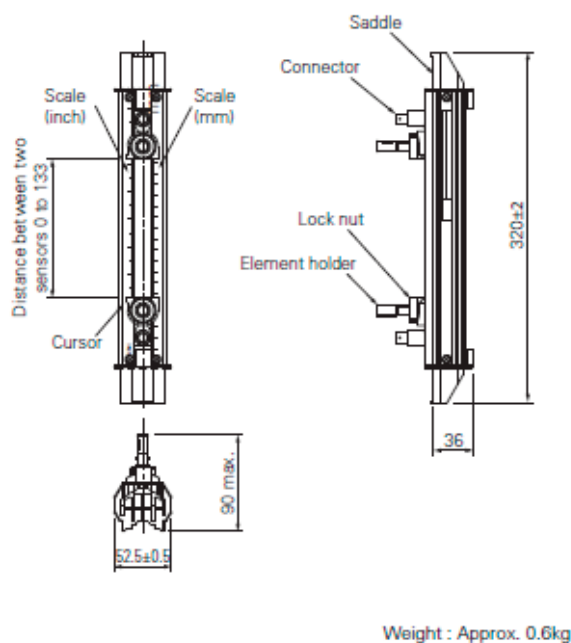

Small diameter sensor: FSSD1

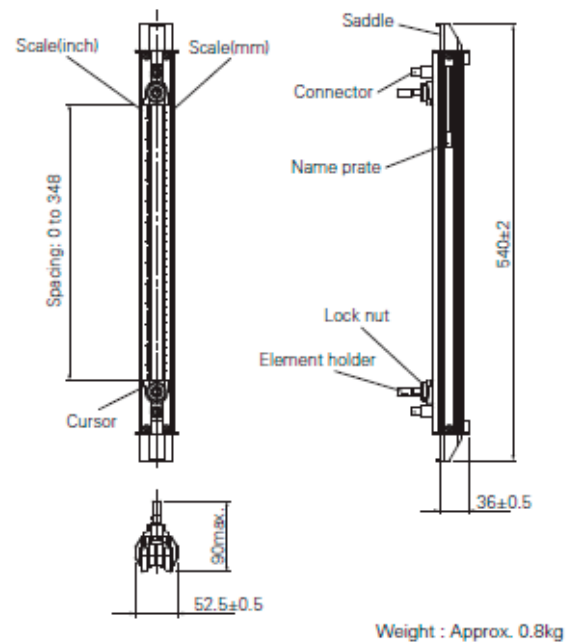

Detector FSSD3

Detector for special application 2) detector for high temperature

Pipe size: $\varnothing 50$ to 400mm
 Fluid temperature: -40 to 200°C
 Type: FSSH1□□1-Y□

Specification

- Sensor frequency: 2MHz
- Mounting method: V method ($\varnothing 50$ to 250mm) or Z method ($\varnothing 150$ to 400mm)
- Fluid temperature: -40 to 200°C
- Applicable pipe material: PVC, SS, carbon steel pipe, copper pipe, aluminum pipe, etc.
 [In case lining is removed from the pipe, Measurement can not be conducted]

- Rated accuracy of combination with the flow transmitter (Applicable piping: plastic, metal pipe)

| Internal diameter (mm) | Velocity | Accuracy |
|--|---------------|------------------------|
| $\varnothing 50$ to $\varnothing 300$ | 2 to 32m/s | $\pm 1.0\%$ of rate |
| | 0 to 2m/s | $\pm 0.02\text{m/s}$ |
| $\varnothing 300$ to $\varnothing 400$ | 0.75 to 32m/s | $\pm 1.0\%$ of rate |
| | 0 to 0.75m/s | $\pm 0.0075\text{m/s}$ |

- Mounting belt: according to specified code of symbol.
- Material: sensor housing: SUS304
 guide rail: SUS304 + aluminum alloy
- Type of enclosure: IP52
- Acoustic coupler: according to specified code of symbol.
- Mass: 1.6kg

OUTLINE DIAGRAM (unit: mm)

<Detector>

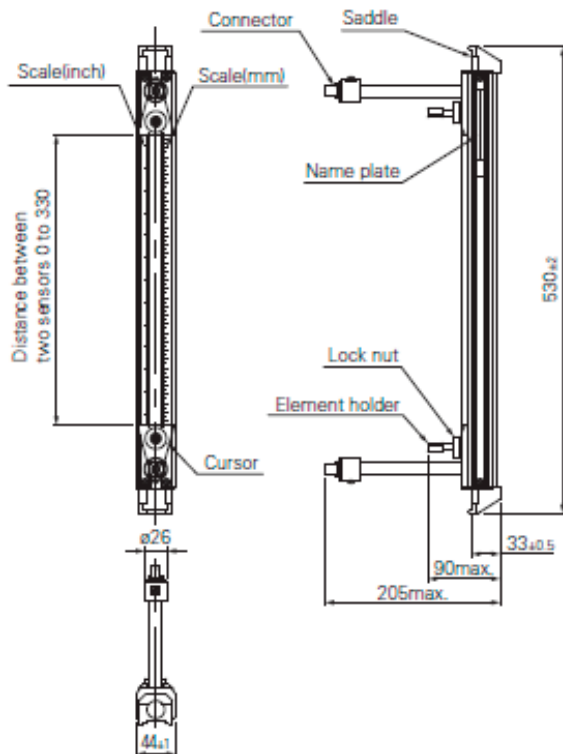

High-temperature sensor: FSSH

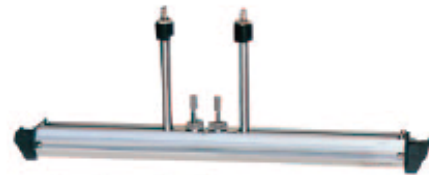

CODE SYMBOL

<Detector>

| 1 | 2 | 3 | 4 | 5 | 6 | 7 | 8 | 9 | 10 | Description |
|---|---|---|---|---|---|---|---|---|----|---|
| F | S | S | H | 1 | 1 | | | | | <Sensor type>(4th digits) $\varnothing 50$ to $\varnothing 400\text{mm}$ (-40 to 200°C) |
| | | | | H | | | | | | <Guide rail>(5th digits) Provided |
| | | | | | 1 | | | | | <Mounting belt>(6th digits) None Stainless belt (1.5m \times 2) SS belt fasten with screws (1.0m \times 4) |
| | | | | | | Y | | | | <Acoustic coupler> (7th digit) None High-temperature grease (KS62M) |
| | | | | | | | A | | | <Water-proof treatment>(9th digit) None |
| | | | | | | | | Y | | <Tag plate> (10th digit) None Provided |

OPTIONAL ACCESSORIES

| Name | Drawing No. |
|---|----------------|
| Guide rail for high-temperature sensor (Z method) | ZZP*TK4J5917C3 |
| High-temperature grease(KS62M) | ZZP*TK7G7983C1 |

Scope of delivery

- Detector, acoustic coupler and set of the mounting belt according to specified code of symbol

Detector for special application 3) detector for large diameter type

Pipe size: $\varnothing 200$ to 6000mm
 Fluid temperature: -40 to 80°C
 Type: FSSE1□□1-Y□



Specification

- Sensor frequency: 0.5MHz
- Mounting method: V or Z method
- Fluid temperature: -40 to 80°C
- Applicable pipe material: PVC, SS, carbon steel pipe, copper pipe, aluminum pipe, etc.
 - * In case lining is removed from the pipe, Measurement can not be conducted
- Also applicable to water-proof type according to specified code of symbol (submerged resistant structure for 5days including 10m cable)
- Rated accuracy of combination with the flow transmitter (Applicable piping: plastic, metal pipe)

| Internal diameter (mm) | Velocity | Accuracy |
|--|---------------|------------------------|
| $\varnothing 200$ to $\varnothing 300$ | 2 to 32m/s | $\pm 1.5\%$ of rate |
| | 0 to 2m/s | $\pm 0.03\text{m/s}$ |
| $\varnothing 300$ to $\varnothing 1200$ | 0.75 to 32m/s | $\pm 1.5\%$ of rate |
| | 0 to 0.75m/s | $\pm 0.0113\text{m/s}$ |
| $\varnothing 1000$ to $\varnothing 6000$ | 1 to 32m/s | $\pm 1.0\%$ of rate |
| | 0 to 1m/s | $\pm 0.02\text{m/s}$ |

- Mounting belt: according to specified code of symbol.
- Material: Sensor housing PBT, Sensor cover SUS304
- Type of enclosure: IP67
(silicon rubber is filled up on the terminal block when connecting work)
- Acoustic coupler: according to specified code of symbol.
- Mass: 1.2kg

OUTLINE DIAGRAM (unit: mm)

<Detector>

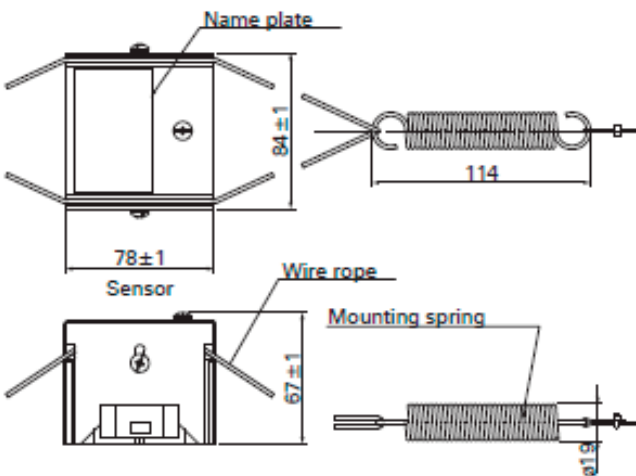

Large sensor: FSSE

CODE SYMBOL

<Detector>

| 1 | 2 | 3 | 4 | 5 | 6 | 7 | 8 | 9 | 10 | Description |
|---|---|---|---|---|---|---|---|---|----|---|
| F | S | S | E | 1 | 1 | | | | | <Sensor type>(4th digits) $\varnothing 200$ to $\varnothing 6000\text{mm}$ |
| | | | E | | | | | | | <Guide rail>(5th digits) Provided |
| | | | | 1 | | | | | | <Mounting belt>(6th digits) None Wire $\leq \varnothing 1500\text{mm}$ Wire $\leq \varnothing 6000\text{mm}$ |
| | | | | | Y | | | | | <Acoustic coupler> (7th digit) None Silicon rubber (KE348) Silicone-free grease (HIGH-Z) Silicone grease (G40M) |
| | | | | | | Y | | | | <Water-proof treatment>(9th digit) None Provided (with signal cable 10m) |
| | | | | | | | Y | | | <Tag plate> (10th digit) None Provided |

OPTIONAL ACCESSORIES

| Name | Drawing No. |
|--|-----------------|
| Wire rope for mounting the sensor | |
| • Spring | ZZP*TK745007P1 |
| • Wire rope (up to $\varnothing 500\text{mm}$) | ZZP*TK464686C1 |
| • Wire rope (up to $\varnothing 1000\text{mm}$) | ZZP*TK464686C2 |
| • Wire rope (up to $\varnothing 1500\text{mm}$) | ZZP*TK464686C3 |
| • Wire rope (up to $\varnothing 3000\text{mm}$) | ZZP*TK464686C6 |
| • Wire rope (up to $\varnothing 6000\text{mm}$) | ZZP*TK464686C13 |
| Silicon grease (GM40M) | ZZP*45231N5 |
| Silicon rubber (KE348W) | ZZP*45735N2 |
| Silicone-free grease (HIGH-Z) | ZZP*TK7M0981P1 |

Scope of delivery

- Detector, acoustic coupler and set of the mounting belt according to specified cord of symbol
- Signal cable conversion cord

<Signal cable conversion cord>

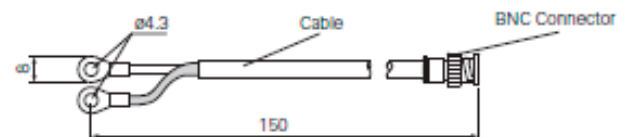

CHECKED ITEMS BEFORE PURCHASE

Following conditions may cause failure of the measurement or to reduce the accuracy by this flow meter.

Please consult and ask Fuji Electric for checking with actual equipment previously if you have hard to judge the appropriate application.

1) Fluid

- If fluid contains a large amount of bubbles (approx. 12vol% or more at 1m/s flow rate)
- If fluid has bad turbidity 10000(mg/L) or more,
- If fluid contains slurry or solid materials (about 5wt%)
- If flow rate is low Reynolds No.10000 or less,
- (reference: flow rate 5m³/h with ø100mm)
- If it is circulating oil, liquid medicine of low concentration, waste liquid and hot spring,

2) Pipe

- If inside pipe is rusty carbon steel pipe,
- If inside pipe having adhering substances and sediment
- If outer surface of cast-iron pipe is rough,
- If pipe wall is thick such as ruinous pipe, (PP material 15mm or more, PVDF material 9mm or more)
- If it is SGPW pipe,
- If lining pipe is removed from pipe, (Teflon, PVC, Glass, etc)
- If it is rubber pipe,

3) Length of the straight pipe

- For accurate measurement, straight pipes are needed between up and down stream side of the measuring part.
- Please meet the straight pipe conditions according page2.

CAUTION ON USE

- 1) Do not damage the sensor or signal mounted on the pipe.
- 2) Make sure to fill the fluid inside the pipe to measure .
- 3) When you use horizontal pipe, it is recommended to install the sensor horizontally.
- 4) When you use the grease as acoustic coupler to install the sensor for outdoor use, it is recommended to install the waterproof cover to prevent from the degradation.

EC Directive Compliance

The product conforms to the requirements of the Low Voltage Directive 2006/95/EC and EMC directive 89/336/EEC (as amended by Directive 92/31/EEC), both as amended by Directive 93/68/EEC.

It conforms to following standards for product safety and electromagnetic compatibility ;

EN61010-1:2010,

Safety requirements for electrical equipment for measurement, control and laboratory use.

"Installation Category II(AC power adapter)"

"Installation Category I(Flowtransmitter)"

"Pollution Degree 2"

"Altitude up to 2187yard(2,000m)"

EN61326-1:2006,

CE