

Labom

Diaphragm seal for high pressure applications

welded design with screw-in tread

Type series DD8050



Application area

- Machinery construction
- Chemical and petrochemical industry
- General process technology

Features

- Completely welded design
- Suitable for pressure up to 600 bar
- Volume optimised diaphragm base
- Process connection G1/2 A and 1/2" NPT
- System fillings for different applications
- Measuring device connection:
 - directly welded
 - directly screwed
 - with temperature decoupler
 - with capillary

Options

- NACE compliant
- Oxygen free of oil and grease
- Material certificate acc. to EN 10204-3.1

Application

Suitable for mounting to bourdon tube pressure gauges and pressure transmitters. The diaphragm seal welded design is suited for measuring aggressive media and for high process temperatures.

Technical data

Constructional design

- Design:
- PN 60
max. pressure 60 bar at max. 200 °C
 - PN 600
max. pressure 600 bar at max. 200 °C

Higher pressure stages upon request.

Diaphragm: Flat diaphragm

Material wetted parts: Diaphragm:
Stainless steel mat.-no. 1.4435 (316L),
alternative Hastelloy C276.
Further materials upon request.

Basic body:
Stainless steel mat.-no. 1.4404/1.4435
(316L), alternative Hastelloy C276

Further materials upon request.

Process connection

Design: G1/2 A per EN 837-1
1/2" NPT per EN 837-1

Sealing are not included in the scope of delivery.

Measuring device connection

See order details.
Material stainless steel mat.-no. 1.4301 (304)

System filling

See order details; further upon request.
Further details about pressure transmission fluids see general technical information TA_038.

Temperature error

In order to optimise the system we provide a detailed error calculation upon request.

Weight

Without measuring device connection approx. 360 g (PN 600).

Further information about diaphragm seals see general technical information TA_031.

Measuring device connection

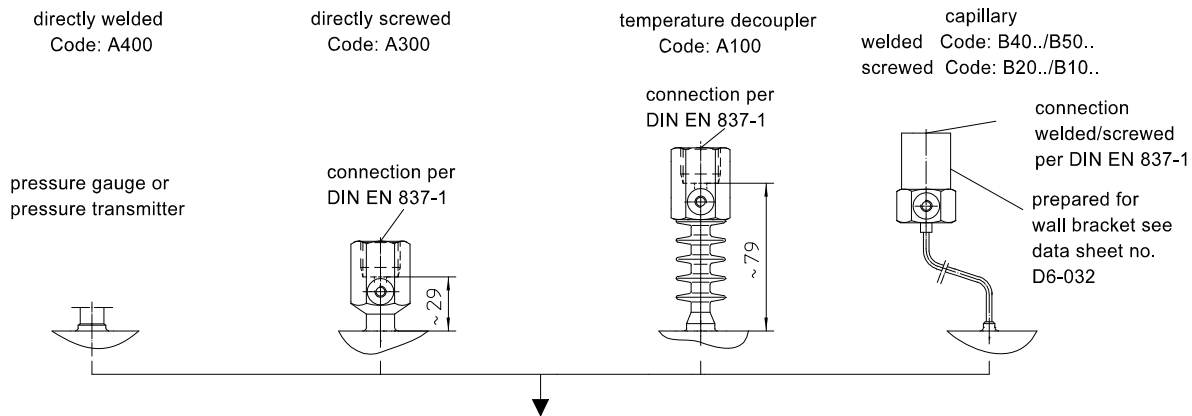

Dimensions

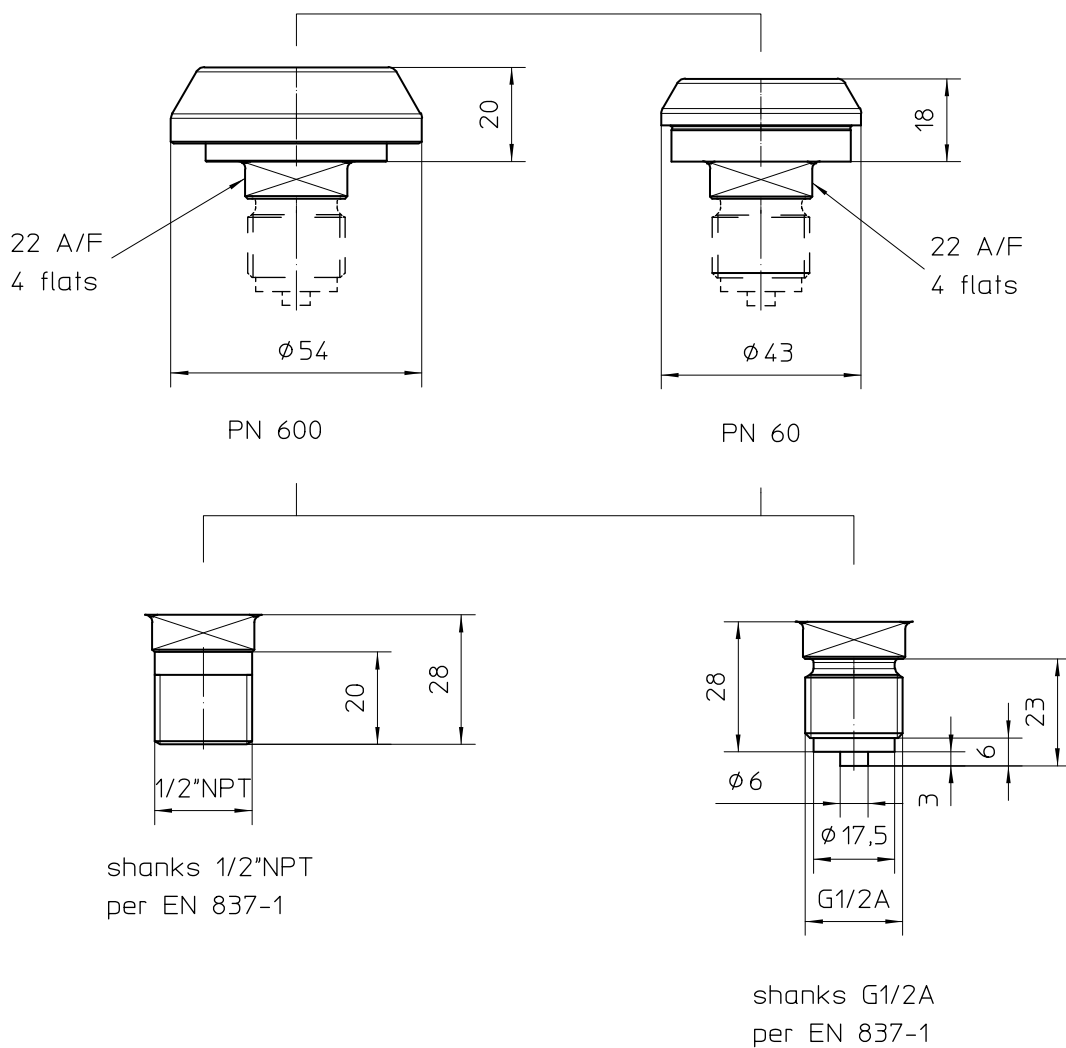

Order details

Diaphragm seal for high pressure applications, welded design Type series DD8050

Order details diaphragm seal DD8050					
DD8050	Diaphragm seal for high pressure applications, welded design				
D3 ..	nominal pressure	PN 60			
D6 ..		PN 600			
10	process connection	G1/2 A			
51		1/2" NPT			
E1	material	basic body/process connection	stainless steel mat.-no. 1.4404/1.4435 (316L)		
E3			Hastelloy C 276		
G7		diaphragm	stainless steel mat.-no. 1.4435 (316L)		
G3			Hastelloy C 276		
A400	measuring device connection	directly	welded		
A300			screwed G1/2		
A100		with temperature decoupler	screwed G1/2		
B40 ..			with capillary	welded	
B20 ..		screwed G1/2			
B50 ..		with capillary and stainless steel protective tube	welded		
B10 ..			screwed G1/2		
11			capillary length	1 m	
12				1.6 m	
13		2.5 m			
14		4 m			
21		5 m			
15		6 m			
23		7 m			
16		8 m			
17		10 m			
9	others				
	system filling ¹	<u>pressure transmission fluid</u>	<u>temperature range</u> ²		
L22		synthetic oil, free of silicone FD1, standard	-10...140 °C		
L23		synthetic oil, free of silicone FD1, pls. specify max. temperature	-40...230 °C		
L15		glycerine/water FGW	-30...110 °C		

Additional features (to be indicated in case of need, only)

W1020	material certificate per EN 10204-3.1, wetted parts
W1030	NACE compliant, material certification per MR-0175
W4001	Oxygen free of oil and grease

Order code (example): DD8050 - D310 - E1 - G1 - A400 - L22 - ...

¹ for more detailed information about pressure transmission fluids see TA_038.
Please state temperature range to allow an accurate calculation of the system.

² max. media temperature for pressures > 0 bar rel.