

**Labom**

## Diaphragm seal

HYGIENIC Tubus Ø 43.3 mm with screwing DN 25

Type series DL9014



### Application area

- Food industry
- Pharmaceutical industry
- Biotechnology

### Features

- Flush-mounted separating diaphragm of stainless steel, laser welded
- Volume optimised diaphragm base
- System fillings for different applications
- Measuring device connection:
  - directly welded
  - directly screwed
  - with temperature decoupler
  - with capillary

### Options

- Certificates
  - Material certificate acc. to EN 10204-3.1
- Electropolishing (wetted parts)
- Hygienic design with advanced surface quality

### Application

Suitable for mounting to bourdon tube pressure gauges and pressure transmitters. The diaphragm seal HYGIENIC Tubus is used mainly for dead-zone free pressure measurement.

## Technical data

### Constructional design

Basic body:	Volume reduced diaphragm base Material: stainless steel mat.-no. 1.4404/1.4435 (316L)
Union nut:	Material: stainless steel mat.-no. 1.4301 (304)
Diaphragm:	Flat diaphragm
Material wetted parts:	Diaphragm: Stainless steel mat.-no. 1.4435 (316L)  Basic body: Stainless steel mat.-no. 1.4404/1.4435 (316L)

### Process connection

Design:	HYGIENIC Tubus: Ø 43.3 mm
Diaphragm surface:	Ø 33 mm
Nominal pressure:	PN 40
Gasket:	Material silicone, FDA compliant Temperature range: -50...200 °C

### Measuring device connection

See order details.  
Material stainless steel mat.-no. 1.4301 (304)

### System filling

See order details; further upon request.  
Further details about pressure transmission fluids see general technical information TA\_038.

### Hygienic design

The surface roughness of the wetted parts made of stainless steel are executed according to EHEDG Doc.8 and ASME BPE SF3.  
In case of choosing the additional feature HY, we guarantee the following surface roughness values:

Diaphragm foil:	Ra ≤ 0.38 µm
Laser welds:	Ra ≤ 0.76 µm
Turned parts:	Ra ≤ 0.76 µm

Further versions of hygienic design upon request.

### Temperature error

In order to optimise the system we provide a detailed error calculation upon request.

### Weight

With measuring device connection G1/2 approx. 1.0 kg

**Further information about diaphragm seals see general technical information TA\_031.**

## Measuring device connection

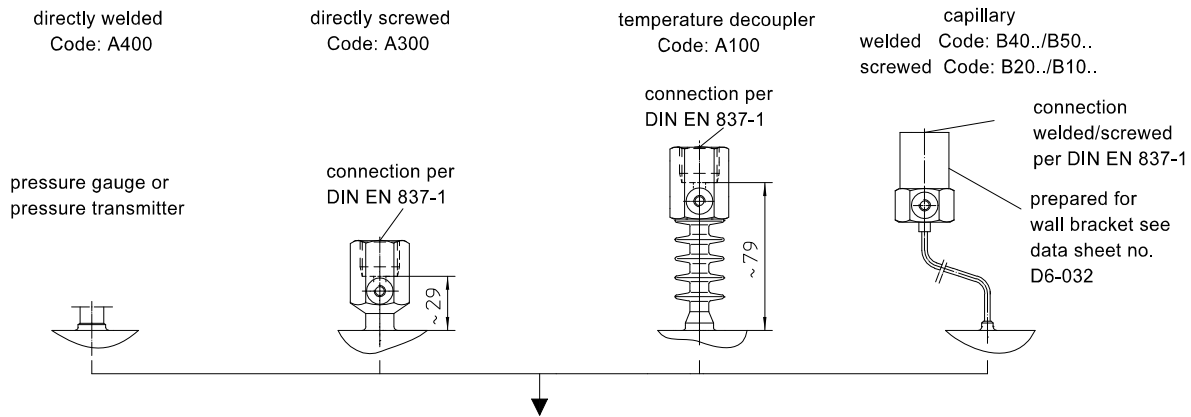

## Dimensions

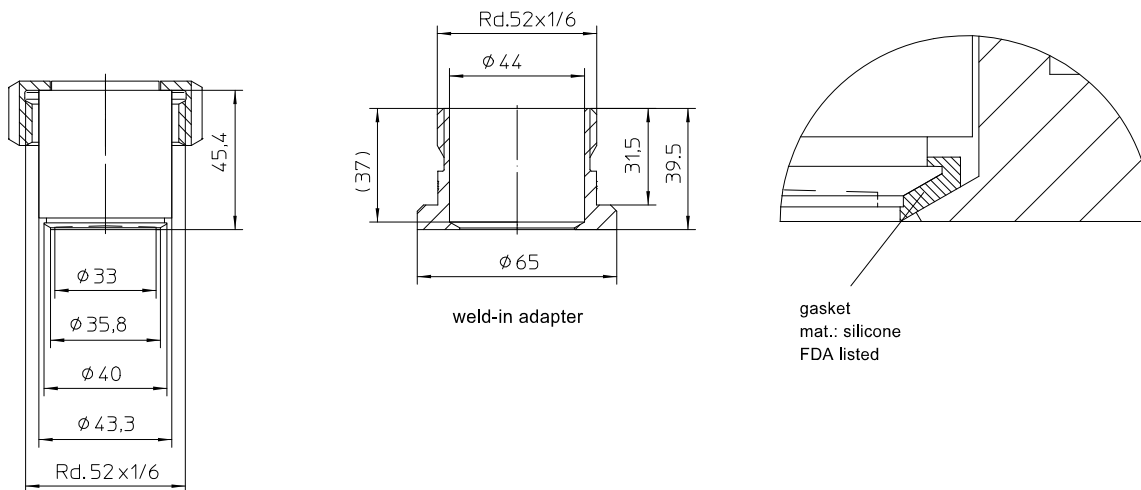

## Order details

### Diaphragm seal HYGIENIC Tubus Ø 43.3 mm with scewing DN 25 Type series DL9014

#### Order details diaphragm seal DL9014

DL9014	design	HYGIENIC Tubus Ø 43.3 mm		
HY	surface roughness	Hygienic version as per EHEDG Doc.8 and ASME BPE SF3		
E1	basic body material	stainless steel mat.-no. 1.4404/1.4435 (316L)		
G7	diaphragm material	stainless steel mat.-no. 1.4435 (316L)		
H3	gasket	silicone, FDA compliant, temperature range -50...200 °C		
A400	measuring device connection	directly	welded	
A300			screwed G1/2	
A100		with temperature decoupler	screwed G1/2	
B40..		with capillary	welded	
B20..			screwed G1/2	
B50..		with capillary and stainless steel protective tube	welded	
B10..			screwed G1/2	
11		capillary length	1 m	
12			1.6 m	
13			2.5 m	
14			4 m	
21			5 m	
15			6 m	
23			7 m	
16			8 m	
17			10 m	
9	others			
		<u>pressure transmission fluid</u>	<u>temperaturr range<sup>2</sup></u>	
L22	system filling <sup>1</sup>	synthetic oil, free of silicone FD1, standard	-10...140 °C	
L23		synthetic oil, free of silicone FD1, please specify max. temperature	-40...230 °C	

#### Additional features (to be indicated in case of need, only)

W1020	material certificate acc. to EN 10204-3.1, wetted parts
W4035	electropolishing of wetted parts

#### Accessories

MZ2040-HY	weld-in adapter, stainless steel mat.-no. 1.4571 (316Ti), hygienic design
-----------	---

Order code (example): DL9014 - HY - E7 - G7 - H3 - A400 - L22 - ...

<sup>1</sup> for more detailed information about pressure transmission fluids see TA\_038.

Please state temperature range to allow an accurate calculation of the system.

<sup>2</sup> max. media temperature for pressures > 0 bar rel. The temperature range of the used gasket has to be observed.