

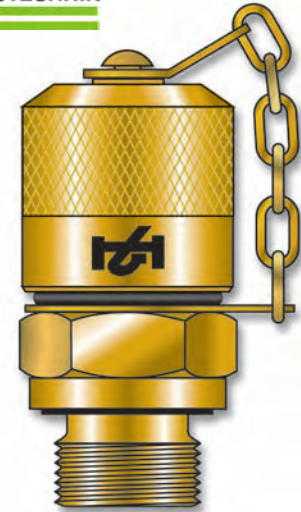

MINIMESS®-1620 Test Points

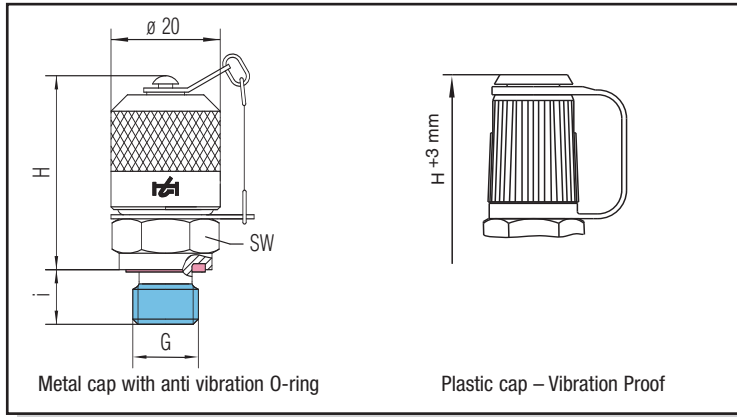
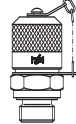
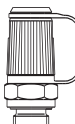

Thread G	Type of seal A	Torque in Nm	Technical data				Material: Free cutting steel 1.0718  Metal cap	Part-number with NBR - sealing	Material: Free cutting steel 1.0718  Plastic cap	Part-number with NBR - sealing	Material: Stainless steel 1.4571  Metal cap	Part-number with FKM - sealing
			p max	H in mm	i in mm	SW in mm						
M 8 x 1*	Form G	6	25 MPa	41	8,5	17	2103-01-32.00	2103-30-32.00	2103-01-32.00	on request		
M 10 x 1		12		37,5	8,5	17	2103-01-33.00				2703-01-33.10	
M 12 x 1,5	Form F	30	63 MPa	36	10	17	2103-01-13.00	2103-30-13.00	2103-01-13.00	on request		
M 14 x 1,5		40		36	10	19	2103-01-14.00				2703-01-14.10	
M 16 x 1,5		60		36	10	22	2103-01-15.00				on request	
M 14 x 1,5	Form E**	45		35,5	11	19	2103-01-96.00	2103-30-96.00	on request			
ISO 228-G 1/8	Form F	18	40 MPa	38	8	17	2103-01-17.00	2103-30-17.00	2103-01-17.00	2703-01-17.10		
ISO 228-G 1/4		40		36	10	19	2103-01-18.00				2703-01-18.10	
ISO 228-G 3/8		60	36	10	22	2103-01-16.00	on request					
1/8 NPTF	Form H	-	40 MPa	33	9,5	17	2103-01-46.00	2103-30-46.00	2103-01-46.00	on request		
1/4 NPTF		-		33	16,5	17	2103-01-47.00				2703-01-47.10	
7/16-20 UNF	Form E	20	63 MPa	37	9	17	2103-01-21.00	2103-30-21.00	2103-01-21.00	on request		
9/16-18 UNF		35		36	10	19	2103-01-53.00				on request	
ISO 7/I-R 1/8	Form C	-	40 MPa	33	13	17	2103-01-40.00	2103-30-40.00	2103-01-40.00	on request		
ISO 7/I-R 1/4		-		33	13	17	2103-01-41.00				on request	

* M8x1 - Please do not use for new machinery design.

** Form E - ISO 6149-2.

Option

For sealing in FKM (Viton) Exchange end digits from 00 to 10

10

Other materials, designs, sealing and screw-in threads on request.
 We reserve the right to carry out technical modifications.

1 MPa = 10 bar

ICS Schneider Meßtechnik GmbH
 Briesestraße 59
 D-16562 Bergfelde / Berlin

Tel.: 03303 / 504066
 Fax: 03303 / 504068

info@ics-schneider.de
 www.ics-schneider.de

MINIMESS®-1620 Test Points Metric DKO, Tee Adaptors - 1620

For solder free screw-in pipe connections according to DIN 2353; free-cutting steel 1.0718; sealing NBR

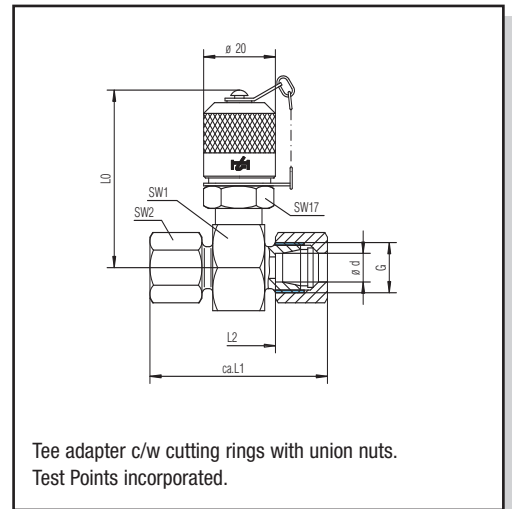
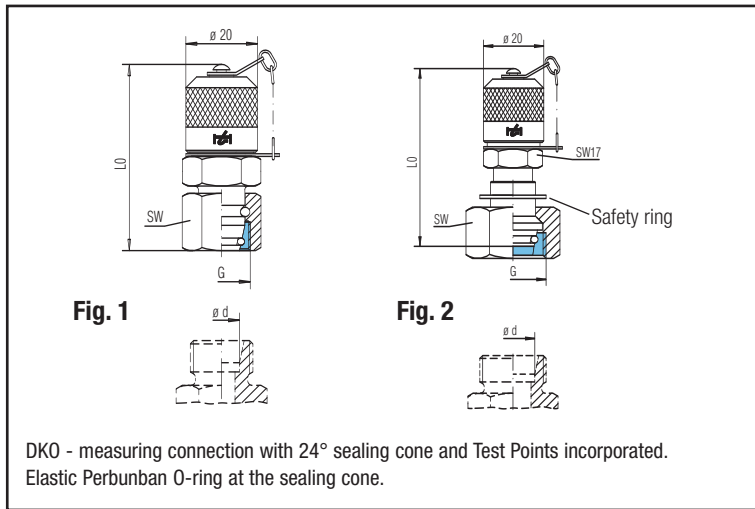

Series Ø d	p max	Thread G
L 6	31,5 MPa	M 12 x 1,5
L 8		M 14 x 1,5
L 10		M 16 x 1,5
L 12		M 18 x 1,5
L 15		M 22 x 1,5
L 18		M 26 x 1,5
L 22	16 MPa	M 30 x 2
L 28		M 36 x 2
L 35		M 45 x 2
L 42		M 52 x 2

Fig.	L ₀	SW	Part-number
1	52	14	2103-93-06.00
	52	17	2103-93-08.00
	52	19	2103-93-10.00
	52	22	2103-93-12.00
	52	27	2103-93-15.00
	52	32	2103-93-18.00
2	60	36	2103-40-22.00
	61	41	2103-40-28.00
	63	50	2103-40-35.00
	63	60	2103-40-42.00

L ₁	L ₂	L ₀	SW ₁	SW ₂	Part-number
50,5	20,5	49,5	24	14	2103-11-06.00
50,5	20,5	49,5	24	17	2103-11-08.00
52,5	22,5	49,5	24	19	2103-11-10.00
52,5	22,5	49,5	24	22	2103-11-12.00
54,5	24,5	52,5	30	27	2103-11-15.00
56,5	23,5	53,5	32	32	2103-11-18.00
60,5	27,5	55,5	36	36	2103-11-22.00
60,5	27,5	58	41	41	2103-11-28.00
68,5	25,5	60,5	46	50	2103-11-35.00
70,5	24,5	65	55	60	2103-11-42.00

Series Ø d	p max	Thread G
S 6	63 MPa	M 14 x 1,5
S 8		M 16 x 1,5
S 10		M 18 x 1,5
S 12		M 20 x 1,5
S 14	M 22 x 1,5	
S 16	40 MPa	M 24 x 1,5
S 20		M 30 x 2
S 25		M 36 x 2
S 30	M 42 x 2	
S 38	31,5 MPa	M 52 x 2

Fig.	L ₀	SW	Part-number	
1	52	17	2103-94-06.00	
	52	19	2103-94-08.00	
	52	22	2103-94-10.00	
	52	24	2103-94-12.00	
2	63	27	2103-41-14.00	
1	52	30	2103-94-16.00	
	63	36	2103-41-20.00	
	2	64,5	46	2103-41-25.00
		66	50	2103-41-30.00
69	60	2103-41-38.00		

L ₁	L ₂	L ₀	SW ₁	SW ₂	Part-number
54,5	24,5	49,5	24	17	2103-12-06.00
54,5	24,5	49,5	24	19	2103-12-08.00
56,5	23,5	49,5	24	22	2103-12-10.00
56,5	23,5	49,5	24	24	2103-12-12.00
62,5	26,5	51	27	27	2103-12-14.00
62,5	25,5	52,5	30	30	2103-12-16.00
68,5	25,5	55,5	36	36	2103-12-20.00
74,5	26,5	58	41	46	2103-12-25.00
80,5	27,5	60,5	46	50	2103-12-30.00
91	29	65	55	60	2103-12-38.00

Options

All sealing made of Viton with metal cap (when ordering, exchange end digits from 00 to 10)	10
With mounted plastic cap (when ordering, exchange end digits from 00 to 90)	90
All sealing made of Viton with plastic cap (when ordering, exchange end digits from 00 to 95)	95

MINIMESS®-1620 Test Points Metric DKO 1620 Male/Female Tee Adaptors

For solder free screw-in pipe connections according to DIN 2353

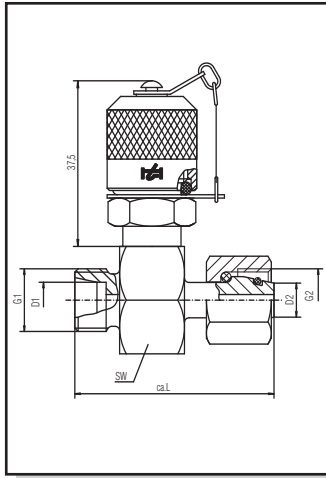

Series	p max	G1	D1	G2	D2	SW	L	Part-number
L 6	31,5 MPa	M 12 x 1,5	6	M 12 x 1,5	6	24	44,5	2103-KL-06.00
L 8		M 14 x 1,5	8	M 14 x 1,5	8	24	44,5	2103-KL-08.00
L 10		M 16 x 1,5	10	M 16 x 1,5	10	24	47,5	2103-KL-10.00
L 12		M 18 x 1,5	12	M 18 x 1,5	12	24	48,5	2103-KL-12.00
L 15		M 22 x 1,5	15	M 22 x 1,5	15	30	51,5	2103-KL-15.00
L 18	16 MPa	M 26 x 1,5	18	M 26 x 1,5	18	32	55,5	2103-KL-18.00
L 22		M 30 x 2	22	M 30 x 2	22	36	58,5	2103-KL-22.00
L 28		M 36 x 2	28	M 36 x 2	28	41	59	2103-KL-28.00
L 35		M 45 x 2	35	M 45 x 2	35	46	68	2103-KL-35.00
L 42		M 52 x 2	42	M 52 x 2	42	55	68	2103-KL-42.00

Series		G1	D1	G2	D2	SW	L	Part-number
S 6	63 MPa	M 14 x 1,5	6	M 14 x 1,5	6	24	46,5	2103-KS-06.00
S 8		M 16 x 1,5	8	M 16 x 1,5	8	24	48,5	2103-KS-08.00
S 10		M 18 x 1,5	10	M 18 x 1,5	10	24	49,5	2103-KS-10.00
S 12		M 20 x 1,5	12	M 20 x 1,5	12	24	50	2103-KS-12.00
S 14		M 22 x 1,5	14	M 22 x 1,5	14	27	53,5	2103-KS-14.00
S 16	40 MPa	M 24 x 1,5	16	M 24 x 1,5	16	30	56,5	2103-KS-16.00
S 20		M 30 x 2	20	M 30 x 2	20	36	64,5	2103-KS-20.00
S 25		M 36 x 2	25	M 36 x 2	25	41	66	2103-KS-25.00

MINIMESS®-1620 Test Points 1620 Bulkhead Adaptors

For solder free screw-in pipe connections according to DIN 2353, to MINIMESS® - 1620 Test Points, NBR sealing

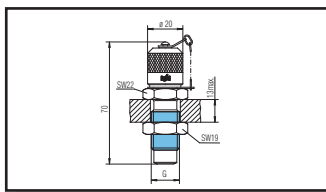
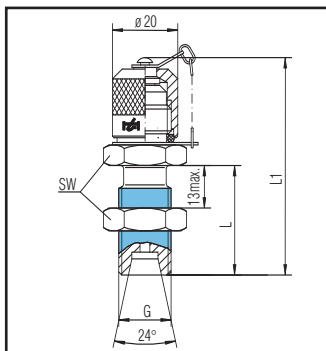

Thread G	p max	Connectoin	L in mm	L ₁ in mm	SW in mm	Part-number
M 12 x 1,5	31,5 MPa	L 6	34	67	17	2103-04-22.00
M 14 x 1,5		L 8	34	67	19	2103-04-23.00
M 16 x 1,5		L 10	33,5	66,5	22	2103-04-18.00
M 14 x 1,5	63 MPa	S 6	36	69	19	2103-04-24.00
M 16 x 1,5		S 8	33,5	66,5	22	2103-04-25.00
M 18 x 1,5		S 10	37	70	24	2103-04-26.00

Thread G	p max	Connectoin	Part-number
M 16 x 2	63 MPa	Both sides for MINIMESS® 1620 (M 16 x 2)	2103-04-16.00

MINIMESS®-1620 Test Points

1620 Standpipe adaptor 37° - edged screwing SAE J514

NBR sealing

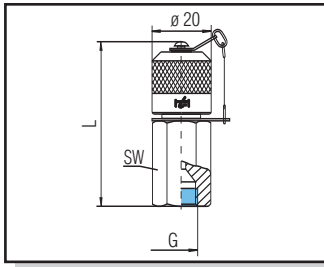

Thread G	p max	Pipe Ø in mm	Pipe Ø in inch	L in mm	SW in mm	Part-number
7/16-20 UNF	60 MPa	6	1/4"	55	17	2103-85-21.00
1/2 -20 UNF	42 MPa	8	5/16"	56,5	17	2103-85-22.00
9/16-18 UNF	31,5 MPa	10	3/8"	57,5	19	2103-85-23.00
3/4- 16 UNF		12	1/2"	60,5	22	2103-85-24.00

MINIMESS®- pressure gauge connection for bulkhead fitting

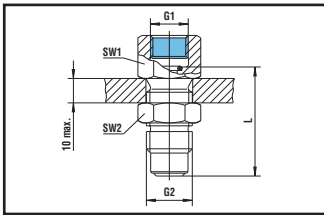

Internal thread G1	p max	Connection G2	L in mm	SW in mm	Note	Part-number
ISO 228-G 1/4	63 MPa	1620 / M 16 x 2	38	19	Without return valve	2103-05-11.00
ISO 228-G 1/2			42,5	27		2103-05-12.00
1/4 NPT			-	19		2103-05-23.00

MINIMESS®-1620 pressure gauge – direct connection

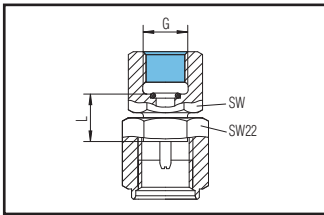

Internal thread G	p max	L in mm	SW in mm	Part-number
ISO 228-G 1/4	63 MPa	14,5	19	2103-07-11.62
ISO 228-G 1/2		17	27	2103-07-12.62
1/4 NPT		-	19	2103-07-23.62

MINIMESS®-1620

90° Swivel screw connection

NBR sealing

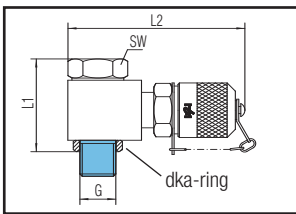

Thread G	p max	L ₁ in mm	L ₂ in mm	SW in mm	Part-number
ISO 228-G 1/4	63 MPa	34,5	64,5	19	2115-22-34.00

Sealing on screw-in thread (hollow screw) via dka-ring, on hexagon via Gi-ring (NBR). Other options on request.

MINIMESS®-1620 hose adaptor

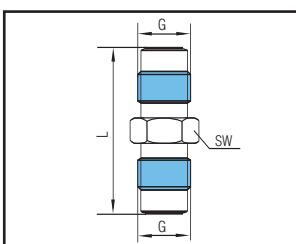

Thread G	p max	L in mm	SW in mm	Note	Part-number
M 16 x 2	63 MPa	42	17	Without return valve	2146-01-00.00

Other materials, further executions, sealing and screw-in threads on request.

MINIMESS®-1620 p/T Test Points

for pressure and temperature measurement

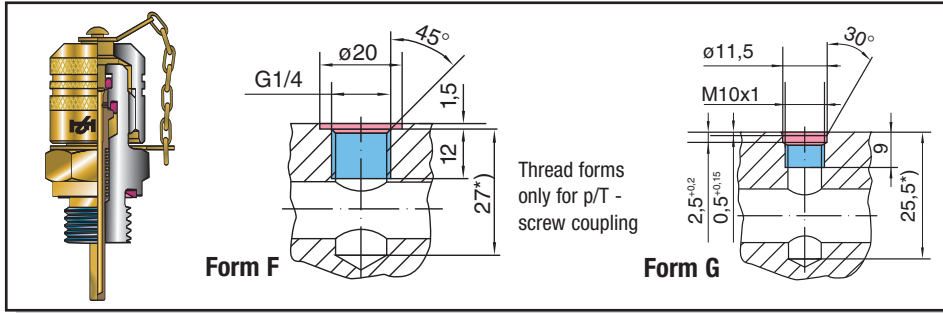
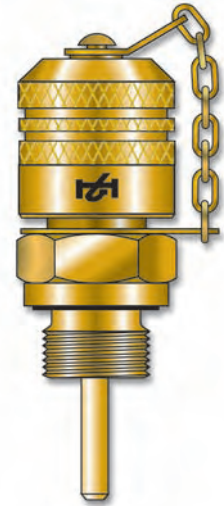

*) = recommended min. depth of drill

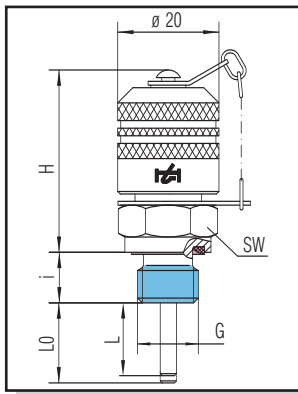

Thread G	Type of sealing A	Torque in Nm	Technical data						SW in mm	Part-number with NBR - sealing
			p max	H in mm	i in mm	L ₀ in mm	L in mm			
ISO 228-G 1/4	Form F	40	63 MPa	36,5	10	16	14,5	19	2149-04-15.13	
M 10 x 1	Form G	12		38	8,5	16	14,5	17	2149-04-19.13	

L₀ = max. immersion depth in coupled state, L = not coupled state

Option

For FKM (Viton) - exchange end digits from 13 to 53

53

Other materials, further options, sealing and screw-in threads on request.
We reserve the right to carry out technical modifications.