

HySense QT 206

CAN turbine volume flow sensor



A version for CAN bus has been adapted from our high-precision turbine volume flow sensors with inside thread connector according to DIN ISO 228 for water and watery media.

The turbines are equipped with floating bearings and factory calibrated for water at 1 cSt. Other calibration viscosities are available on request.

Qualities	
Measuring principle	volume flow
Viscosity range	1 ... 10 mm ² /s (cSt)
Medium temperature	max. +120 °C
Environmental temperature	-20 ... +85 °C
Storage temperature	-20 ... +85 °C
Output signal	CANopen
Supply voltage Ub	8.5 ... 30 VDC
Electrical measuring connector	5 pole device connector, M12 x 1
Protection type (EN 60529 / IEC 529)	IP 67 (screwed)
Tightening torque	10 Nm (± 2 Nm)
Calibration viscosity	30 mm ² /s (cSt)
Material turbine casing	high-grade steel, passivated (X12CrNiS18 8)
Material turbine wheel	1.4122 (for measuring range 1.0 ... 10 l/min) 1.0718 (for all other measuring ranges)
Material sealings	FKM
Material sensor casing	3.1645
Current consumption	max. 50 mA @ 24 VDC
Interface	CANopen (CIA-DS-301)
CAN standard	2.0A (opt. 2.0B)
Transmission rate	20 ... 1,000 kBit/s
Measured frequency (Hz)	bytes 0 ... 3
Measured volume flow (l/min)	bytes 4 ... 7
Resolution	three decimal places
Suitable measuring cable	CAN cable

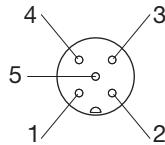
Pin assignment	CANopen
	Pin 1 = CAN_SHLD
	Pin 2 = CAN_V+
	Pin 3 = CAN_GND
	Pin 4 = CAN_H
	Pin 5 = CAN_L

Measuring range	Max. working pressure		Error limit of current value	Weight g	Order number
	l/min	bar			
1.0 ... 10.0	420	42	± 1.0 %	746	33C7-01-35.001
2.0 ... 75.0	420	42	± 0.5 %	1,990	33C7-70-35.001G
9 ... 300	420	42	± 0.5 %	3,590	33C7-71-35.001G
16 ... 600	350	35	± 0.5 %	4,043	33C7-72-35.001G

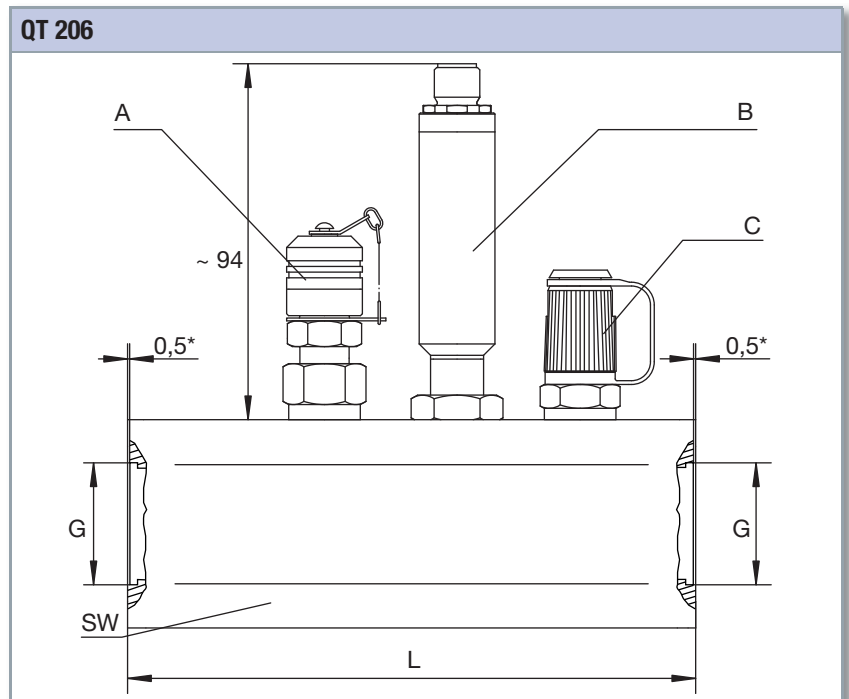

- A MINIMESS® p/T-test point for pressure and temperature, series 1620
- B inductive sensor / amplifier
- C MINIMESS® test point, series 1620
- * depth of spot face

Measuring range	SW	L	G
l/min		mm	
1 ... 10	27	120	ISO 228-G ¹ / ₄
2 ... 75	46	130	ISO 228-G ³ / ₄
9 ... 300	55	150	ISO 228-G1
16 ... 600	60	174	ISO 228-G1 ¹ / ₄

