

Compressed air counter DN 15-50

testo 6441-6444



Measurement of norm volume flow in the measuring range 0.25 to 700 m³/h (DN15 to DN50 or ½"-2"); consumption quantity in m³; media temperature in °C

Highest flexibility thanks to different signal outputs:

- Analog output 4 to 20 mA (4-wire)
 - Pulse output
 - 2 switch outputs (parameterizable: consumption or volume flow-dependent, opener, closer, hysteresis, window)
-

Built-in totalizer, even without additional analysis unit

Operating menu with LED display

m³/h;
l/min;
m³

°C

The compressed air counters testo 6441 to testo 6444 are designed for the measurement, monitoring and recording of compressed air consumption, and therefore also for the determination of leakages in compressed air systems, consumption-based allocation of costs and the implementation of peak load management. Using the compressed air counters testo 6441 to testo 6444, transparency of consumption is created for compressed air, similarly as for the media current, water or gas, thus increasing the motivation of those responsible for the

process regarding cost reduction measures and energy savings. The compressed air counters testo 6441 to testo 6444 record norm volume flow according to the calorimetric principle, which means the measurement procedure is independent of the process pressure and does not cause a permanent pressure drop. While the thermal, glass-coated ceramic sensor offers a high level of robustness and fast response times, the integrated inflow and outflow pipes ensure optimum accuracy.

	testo 6441	testo 6442	testo 6443	testo 6444
--	------------	------------	------------	------------

Measurement parameters

(Norm) volume flow

Selectable units	m ³ /h; l/min; m ³			
Measuring range (1:300) ¹	0.25 to 75 m ³ /h	0.75 to 225 m ³ /h	1.3 to 410 m ³ /h	2.3 to 700 m ³ /h
Accuracy (norm volume flow)	For compressed air quality classes (ISO 8573: particles-humidity-oil) 1-4-1: ±3 % of meas. value ±0.3 % of final value For compressed air quality classes (ISO 8573: particles-humidity-oil) 3-4-4: ±6 % of meas. value ±0.6 % of final value			
Sensor	Thermal, glass-coated ceramic sensor (calorimetric measurement procedure)			
Response time	<0.1 sec (for damping parameter = 0), delayable via operating menu (0 to 1 sec)			
Temperature				
Unit	°C			
Measuring range	0 to +60 °C / 32 °F to +140 °F			

Inputs and outputs

Analog outputs

Output type	4 to 20 mA (4-wire) freely scalable between zero and measuring range end
Load	max. 500 Ω

Further outputs

Pulse output	Consumption quantity counter (value remains available after reset or power cut due to non-volatile memory), value 1 or 10 m ³ , pulse length 0.02 s to 2 s, 24 VDC level
Switch output	2 switch outputs, parameterizable (consumption or volume flow-dependent, opener, closer, hysteresis, window), loadable with max. 20 to 30 VDC or 250 mA each, switch status is displayed via 2 LEDs

Supply

Voltage supply	19 to 30 V DC
Current consumption	<100 mA
Connection	M12 x 1 plug, loadable up to 250 mA, short-circuit-proof (synchronized), reverse-polarity-proof, overload-proof

General technical data

Design

Material housing	PBT (GF 20%), diecast zinc, silica-free			
Long measurement stretch	300 mm	475 mm		
Pipe diameter	DN 15 (for 1/2" pipes)	DN 25 (for 1" pipes)	DN 40 (for 1 1/2" pipes)	DN 50 (for 2" pipes)
Weight	0.9 kg	1.1 kg	3.0 kg	3.8 kg

Display

Material	4-figure alphanumerical display, two operating buttons, operating menu, LED (4 x green for phys. units, 3 x yellow for display x 1,000 or switch status)			
Max. display value norm volume flow	90 m ³ /h	270 m ³ /h	492 m ³ /h	840 m ³ /h
Temperature display	0 to +60 °C, measurement error ±2 K, (+32 to +140 °F)			

Operation

Parameterization	2 operating buttons
------------------	---------------------

Installation

Measurement stretch: thread (both sides) / material	R 1/2, outer thread Stainless steel 1.4301	R1, outer thread Stainless steel 1.4301	R1 1/2, outer thread Stainless steel 1.4401	R2, outer thread Stainless steel 1.4401
---	---	--	--	--

Miscellaneous

Protection class	IP 65/III
EMC	according to guideline 89/336 EEC
Media contact	Materials stainless or galvanized steel, PEEK, polyester, Viton, anodized aluminium ceramic

Operating conditions

Humidity (sensor)	re. humidity <90 %RH
Operating temperature (housing)	0 to +60 °C (+32 to +140 °F)
Storage temperature	-25 to +85 °C (-13 to +185 °F)
Measurement medium	Compressed air, on request also CO ₂ or N ₂
Process pressure	PN 16 (max 16bar/232psi)
Air quality	ISO 8573: recommended classes 1-4-1

¹ Specifications according to DIN 2533 (+15 °C, 1013.25 hPa, 0 %RH)

Technical drawings

testo 6441

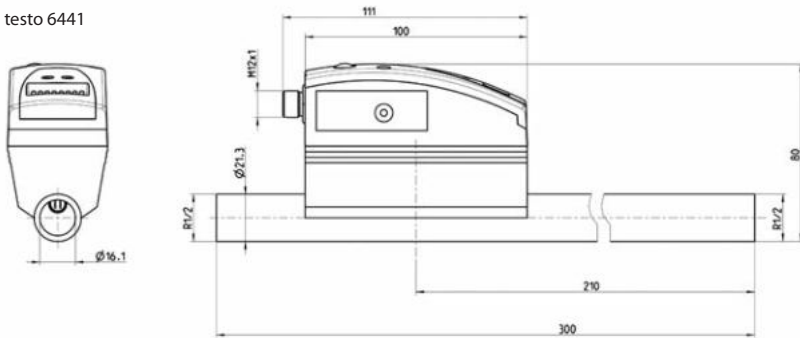

testo 6442

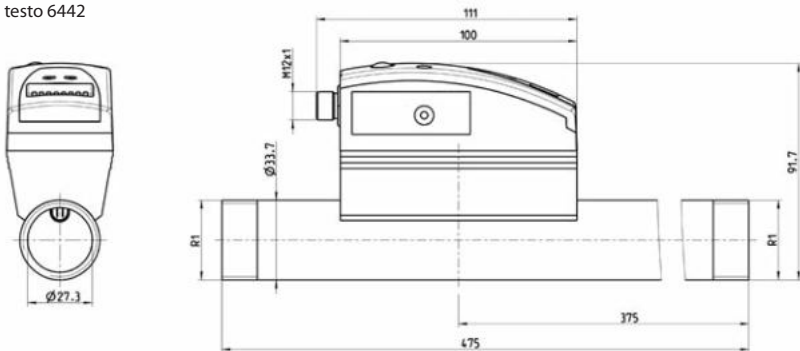

testo 6443

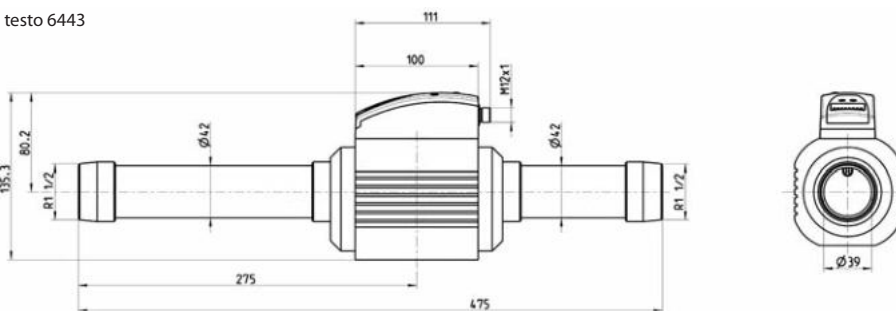

testo 6444

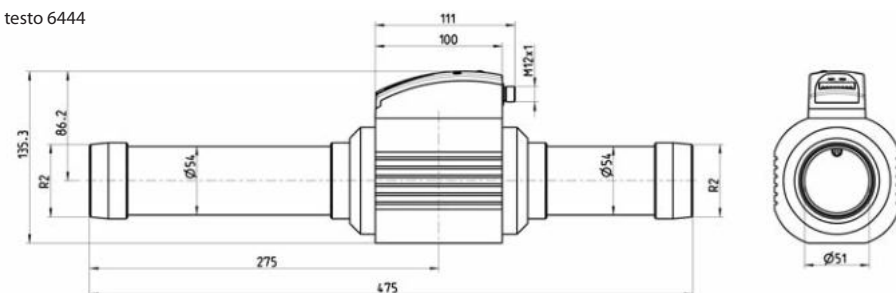

Options / Ordering example

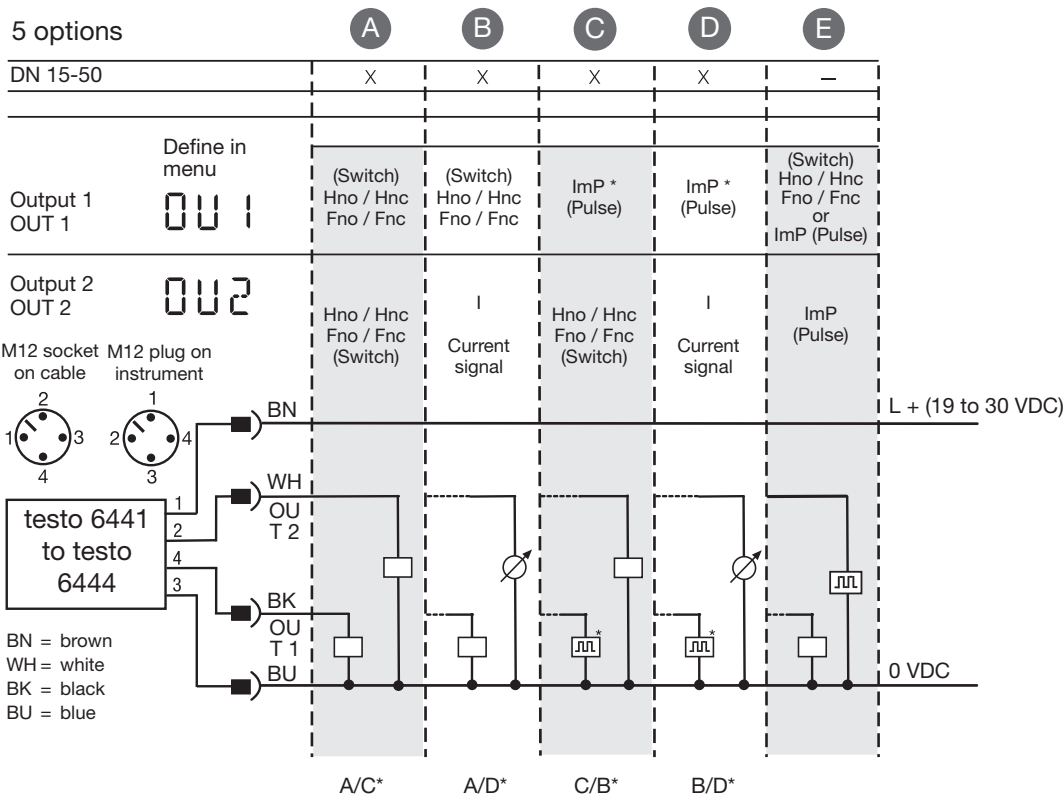

* If menu selection ImPR = Yes -> Pulse output
 If menu selection ImPR = No -> Switch output (pre-selection counter)

Terminal allocation	Wire colours for cable 0699 3393
1 Supply connection 19 to 30 VDC (+)	brown
2 OUT 2 (analog output (4 to 20 mA) or switch output)	white
3 Supply connection 0 V (-)	blue
4 OUT 1 (pulse output or switch output)	black

Order data testo 6441 to testo 6444

Part no.

testo 6441 compressed air counter with integrated inflow/outflow, diameter DN15 (1/2), with analog, pulse and switch output *	0555 6441
testo 6442 compressed air counter with integrated inflow/outflow, diameter DN25 (1), with analog, pulse and switch output *	0555 6442
testo 6443 compressed air counter with integrated inflow/outflow, diameter DN40 (1 1/2), with analog, pulse and switch output *	0555 6443
testo 6444 compressed air counter with integrated inflow/outflow, diameter DN50 (2), with analog, pulse and switch output *	0555 6444

* a connection cable, e.g. part no. 0699 3393, is required for operation