

Bourdon tube pressure gauge Industrial series, NS 80 Models 112.28, 132.28

Applications

- For gaseous and liquid media that are not highly viscous or crystallising
- Model 112.28: Measuring system Cu-alloy
Model 132.28: Measuring system stainless steel, also for aggressive media
- Hydraulics
- Compressors
- Refrigeration technology

Special features

- Vibration and shock resistant
- Especially sturdy design
- Stainless steel case
- Scale ranges up to 0 ... 40 bar



**Bourdon tube pressure gauge model 132.28,
back mount, lettering for refrigeration technology**

Description

Design

EN 837-1

Nominal size in mm

80

Accuracy class

1.6

Scale ranges

Model 112.28: 0 ... 0.6 to 0 ... 40 bar

Model 132.28: 0 ... 1 to 0 ... 40 bar

or all other equivalent vacuum or combined pressure and vacuum ranges

Pressure limitation

Steady: Full scale value

Fluctuating: 0.9 x full scale value

Short time: 1.3 x full scale value

Permissible temperature

Ambient: -40 ... +60 °C

Medium: +60 °C maximum (model 112.28)

+200 °C maximum (model 132.28)

Temperature effect

When the temperature of the measuring system deviates from the reference temperature (+20 °C):

Max. $\pm 0.4\%$ / 10 K of full scale value

Ingress protection

IP 54 per EN 60529 / IEC 529

Standard version

Process connection

Model 112.28: Cu-alloy
 Model 132.28: Stainless steel 316L
 Lower mount (LM) or centre back mount (CBM),
 G 3/8 B (male), 19 mm flats

Pressure element

Model 112.28: Cu-alloy
 Model 132.28: Stainless steel 316L

Movement

Cu-alloy, wear parts argentan

Dial

Aluminium, white, black lettering

Pointer

Aluminium, black

Case

Stainless steel

Window

Polycarbonate

Bezel ring

Crimp ring, glossy finish stainless steel

Options

- Other process connection
- Sealings (model 910.17, see data sheet AC 09.08)
- Liquid filling (glycerine, permissible temperature):
 Ambient: -20 ... +60 °C
 Medium: +60 °C maximum (model 113.28)
 +100 °C maximum (model 133.28)
- Panel frame 88 x 88 mm, stainless steel, black
- Restrictor in the process connection

Dimensions in mm

Standard version

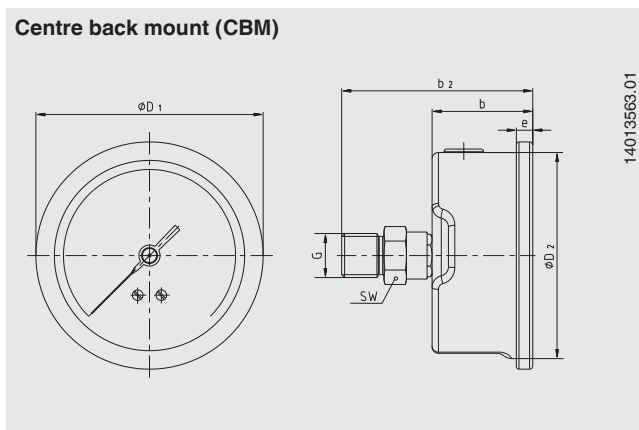
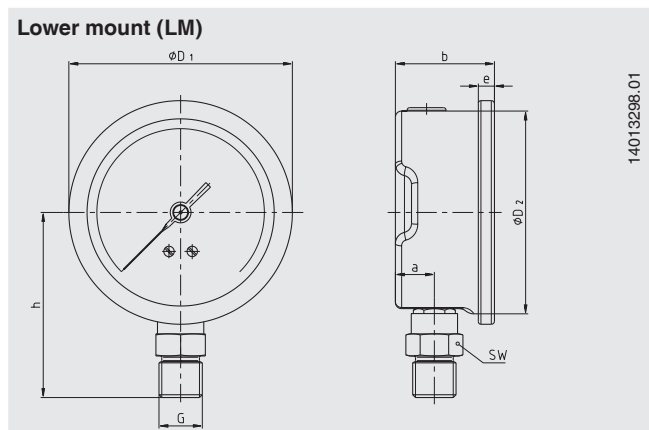

NS	Dimensions in mm									Weight in kg
	a	b ±0.5	b ₂ ±0.5	D ₁	D ₂	e	G	h ±1	SW	
80	15	38	72	86	78	7	G 3/8 B	71	19	0.30

Ordering information

Model / Nominal size / Scale range / Connection size / Connection location / Options

© 2011 WIKA Alexander Wiegand SE & Co. KG, all rights reserved.
 The specifications given in this document represent the state of engineering at the time of publishing.
 We reserve the right to make modifications to the specifications and materials.