

Nemo SX - Multifunction state module

Cat. N°: SXMC02



Contents	Pages
1. Description - Use	1
2. Range.....	1
3. Overall dimensions	1
4. Preparation - Connection.....	1
5. General characteristics	6
6. System architectures	8
6.1 Stand Alone.....	8
6.1.1 with local addressing	8
6.1.2 with remote addressing	9
6.2 Supervised	10
6.2.1 with local addressing	10
6.2.2 with remote addressing	12
7. Compliance and approvals	14

1. DESCRIPTION - USE

- . Module dedicated to Nemo SX System.
- . Enables to display a clear indication on the status of a circuit or of an associated modular devices (MCBs, RCCBs, RCBOs...) and/or power devices (e.g. ACBs, MCCBs...) via voltage-free SPST-NO contacts.
- . Equipped with DIP switches (on the side) allowing product configuration of:
 - type of information returned by the device:
 - open, closed, tripped positions of a modular or power device, etc.
 - LED behaviour
 - other configurations (see § "Module configuration")

Symbol:

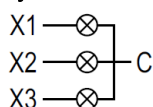

2. RANGE

- . Cat. n° SXMC02: Universal State Module; 3 inputs from voltage-free SPST-NO contact with one common terminal.

Width:

- . 1 module. 17,8 mm width.

3. OVERALL DIMENSIONS

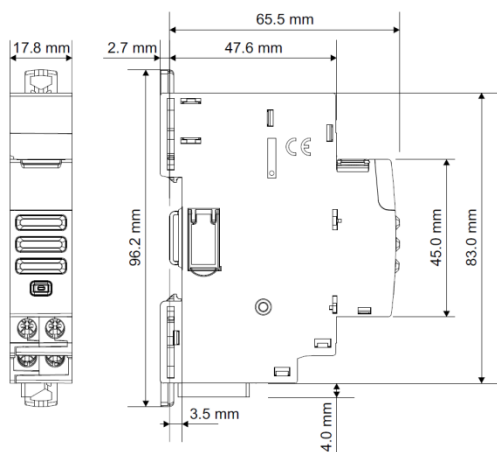

4. PREPARATION -CONNECTION

Fixing:

- . On symmetric rail EN/IEC 60715 or DIN 35 rail

Operating positions:

- . Vertical, Horizontal, Upside down, On the side



Power Supply:

- . Mandatory in 12 V d.c. via the specific Power supply module Cat n°SXAA230
- . Two ways:
 - via specific communication patch cords (cat. nos SXAC250/500/1000) to connect at the downstream through dedicated ports

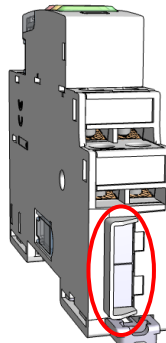

- via specific communication rails (cat. nos SXAR18/24/36) to connect at the rear through dedicated connectors

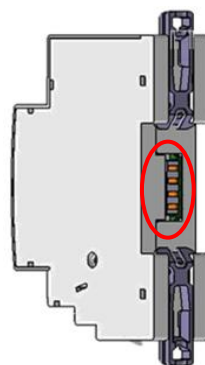

4. PREPARATION –CONNECTION (continued)

Terminals:

- . Terminal depth: 8 mm.
- . Stripping length: 8 mm

Screw head:

- . Mixed, slotted and Pozidriv n°1 (UNI7596 type Z1).

Recommended tightening torque:

- . 1 Nm.

Recommended tools:

- . For the terminals: Pozidriv n°1 or flat screwdriver 4 mm.
- . For fixing: flat screwdriver 5.5 mm (6 mm maximum).
- . For configuration DIP switches: flat screwdriver 2 mm

Conductor type:

	Copper cable	
	Without ferrule	With ferrule
Rigid Cable	1 x 0,5 mm ² to 1,5 mm ² 2 x 1,5 mm ²	-
Flexible Cable	1 x 0,5 mm ² to 1,5 mm ² 2 x 1,5 mm ²	1 x 0,5 mm ² to 1,5 mm ² 2 x 1,5 mm ²

Wirina diagrams:

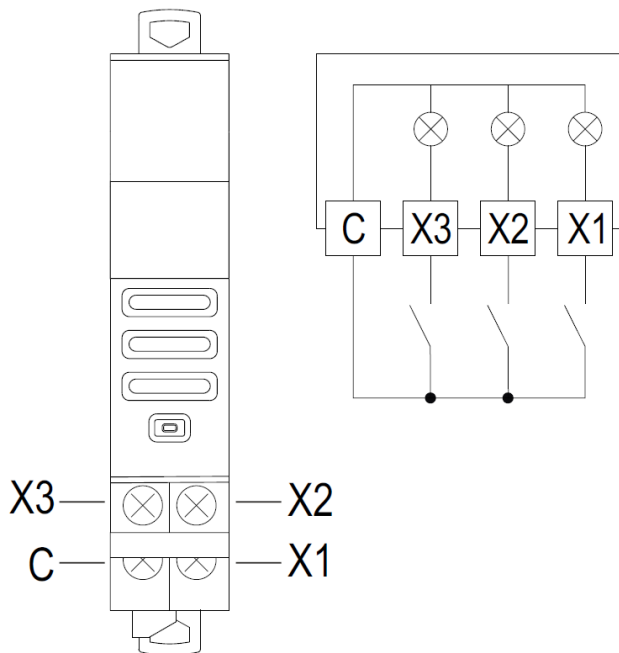

Inputs from voltage-free SPST NO contacts

4. PREPARATION –CONNECTION (continued)

Module configuration:

- . On the left side the Nemo SX module is equipped with 4 DIP switches allowing selection of information type and of the LED behaviour

Dipswitches may be manipulated by a screwdriver

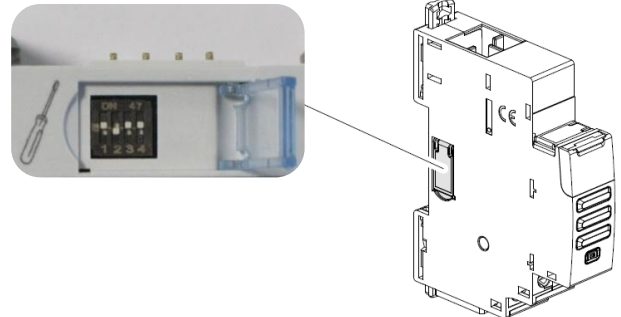

- . Default configuration (switch in 0000 position)



According to the function you want to assign to the module, lateral DIP switch must mandatory be manually auctioned as shown below

If the DIP switch remain in 0000 position, module will display "generic" information (input "active" or "non-active") linked to the 3 inputs state

- . Table of possible configurations

 1 2 3 4		 1 2 3 4	X1 X2 X3	
 1 2 3 4	X1 X2 X3	SLAVE	 1 2 3 4	X1 X2 X3
 1 2 3 4	SLAVE	 1 2 3 4	X1 X2 X3	
 1 2 3 4	X1 X2 X3	 1 2 3 4	X1 X2 X3	

Note 1:

	Steady LED
	Blinking LED
	LED off

4. PREPARATION –CONNECTION (continued)

Connection with an associated device:

. Association with an electro-mechanical auxiliary contact + fault signalling switch.

. Lateral DIP-switches of the Nemo SX module must mandatory be configured as shown

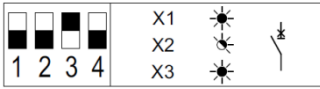

. Wiring diagram:

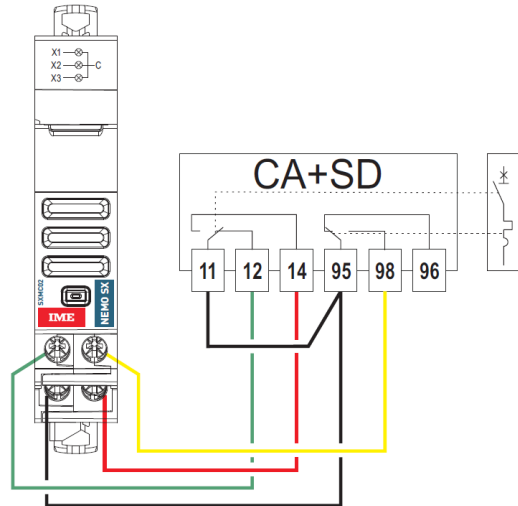

Note:

Open /Close / Tripped displayed information for a protection device. With any kind of electrical protection device (modular or power) the displayed information must be done in accordance with the handle colour status, as shown below:

“I-ON” (red) = contacts closed

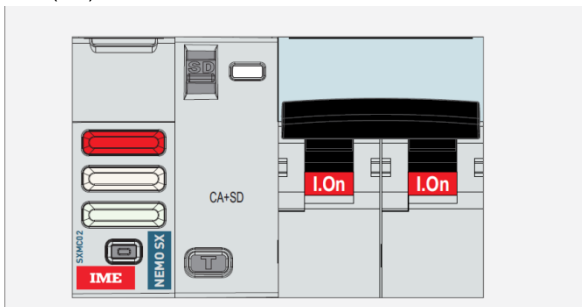

“O-OFF” (green) = contacts open

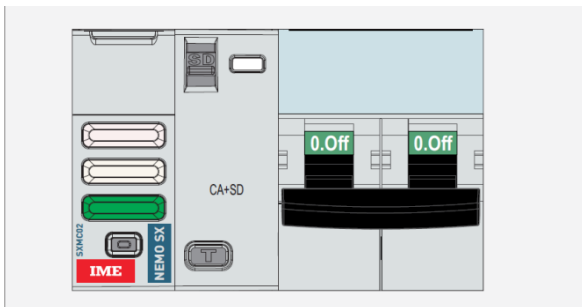

4. PREPARATION –CONNECTION (continued)

Connection with an associated device (continued):

. Association with several electro-mechanical fault signalling auxiliaries.

. Lateral DIP-switches of the Nemo SX module must mandatory be configured as shown

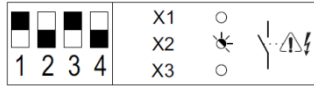

. Wiring diagram:

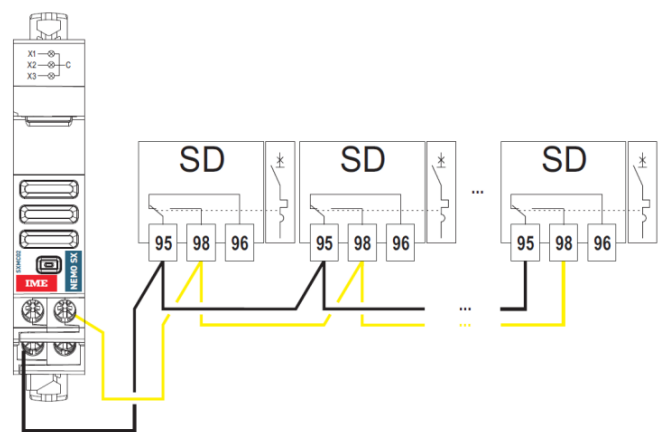

. Association with an electro-mechanical Contactor or Latching relay auxiliary contact.

. Lateral DIP-switches of the Nemo SX module must mandatory be configured as shown

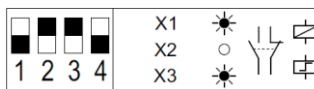

. Wiring diagram:

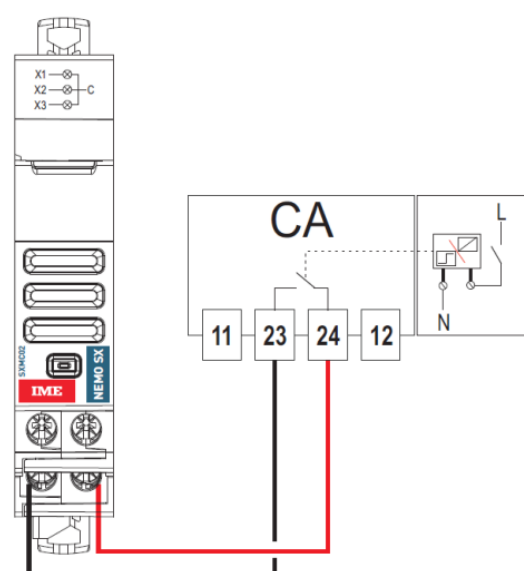

4. PREPARATION –CONNECTION (continued)

Module configuration (continued):

Note 2:

SLAVE = Repeat function

. This configuration allows you to use an Nemo SX Multifunction state module (cat. no SXMC02) as Slave of another Nemo SX Multifunction state module (cat. no SXMC02) Master.

. Slave module, receives via Nemo SX bus and repeats the signalisations of the master module through 3 frontal led.

. No need to wire the terminals of the slave module

. **Slave module must have the same address of the Master module**

. **Example**, Nemo SX Multifunction state module used as slave of another Nemo SX Multifunction state module

. **Lateral DIP-switches of the Nemo SX "Slave" module must mandatory be configured as shown**

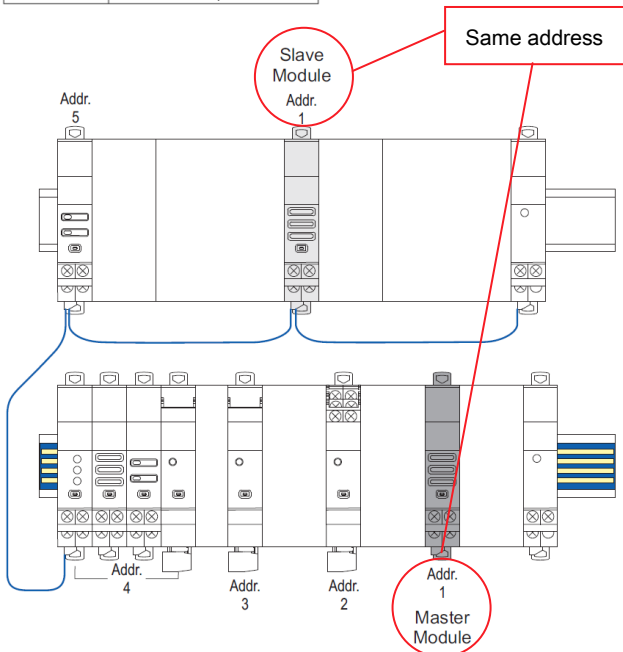
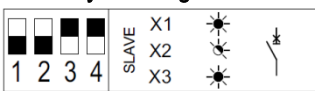

Note: to change the reference "Master module" for a module set as "Slave", it is sufficient assign to the "Slave" the address of the new "Master module".

4. PREPARATION –CONNECTION (continued)

Data connection (Nemo SX modules inter-connection):

. Via specific communication patch cords (cat. nos SXAC250/500/1000)



Allow data transmission between the different Nemo SX modules. This type of connection is recommended when there are few Nemo SX modules, distributed all over the enclosure.

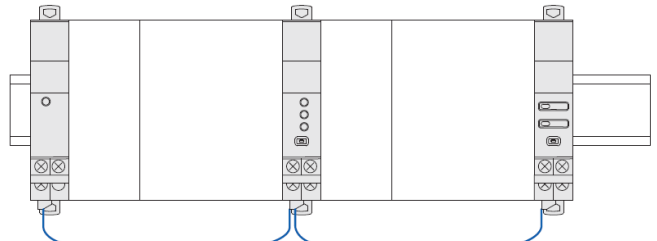

Implementing: with this configuration, the plastic protection cover of the backside communication ports on the Nemo SX module must be kept on.

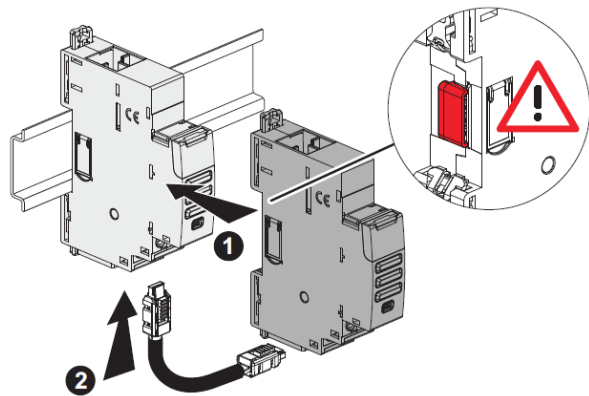

4. PREPARATION –CONNECTION (continued)

Data connection (Nemo SX modules inter-connection)

(continued):

. Via specific communication rails (cat. nos SXAR18/24/36).

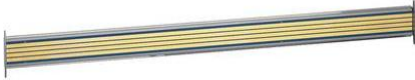

. Allow data transmission between the different Nemo SX modules. This type of connection is recommended when there are several Nemo SX modules on the same DIN row.

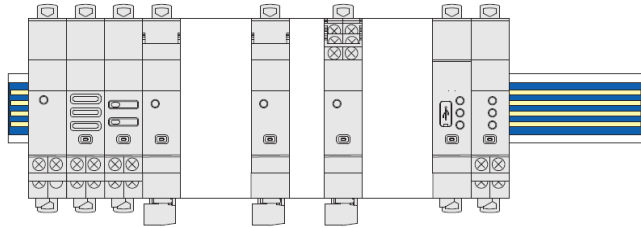

Implementing: with this configuration, the plastic protection cover of the backside communication ports on the Nemo SX module must be removed.

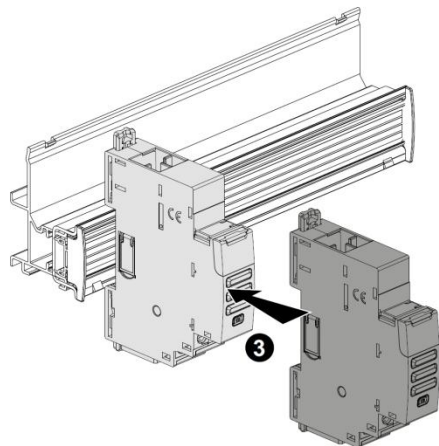
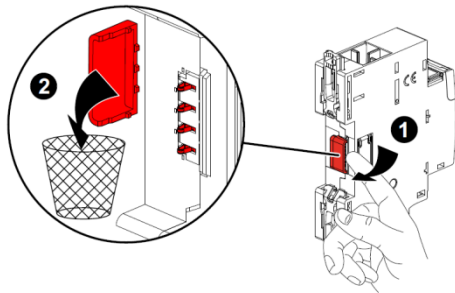

4. PREPARATION –CONNECTION (continued)

Data connection (Nemo SX modules inter-connection)

(continued):

. Via a mix between specific communication patch cords and communication rails in order to create a link between several rows

Two situations:

- Individually connected with communication rails. The communication patch cord allows to connect two rows.

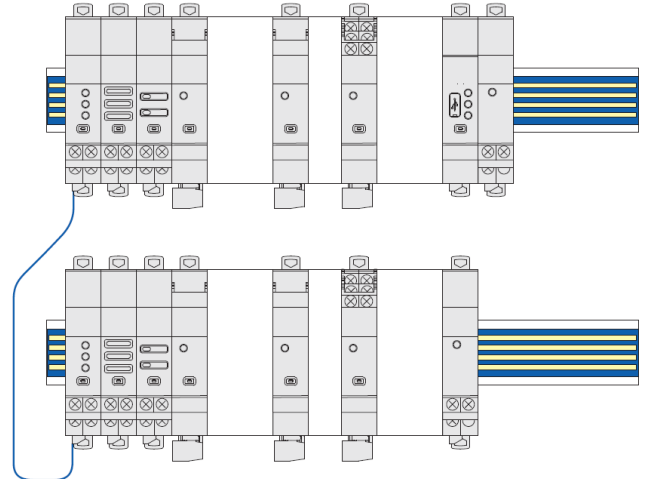

- Individually connected with communication patch cords & communication rail. The communication patch cords allow to connect Nemo SX module on a row and to connect two rows.

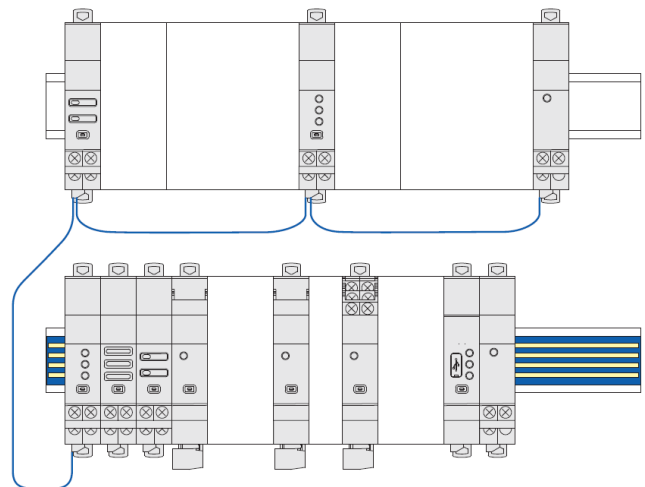

5. GENERAL CHARACTERISTICS

Front face marking:

. By permanent ink pad printing (red line) and laser marking

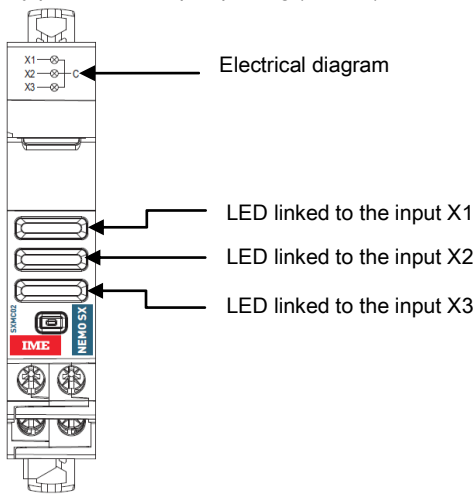

Lateral side marking:

. By laser.

left side: Standard and programming information

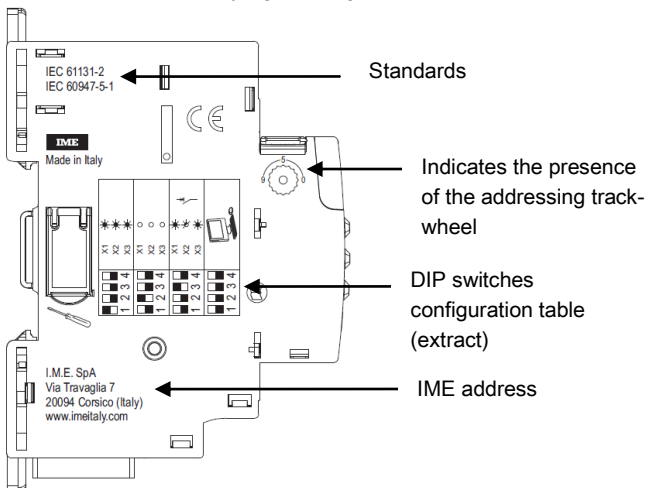

right side: cabling and traceability information

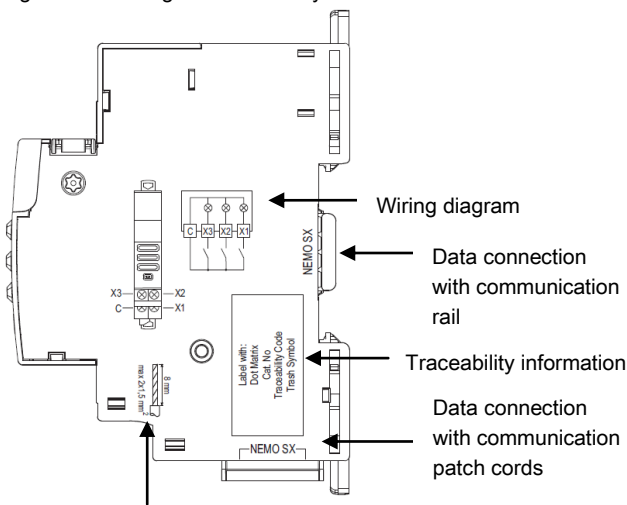

5. GENERAL CHARACTERISTICS (continued)

Signalling LEDs:

. Equipped with configurable signalling LEDs: red, yellow and green (see § "Module configuration"):

- LED turned on: indicates that the corresponding inputs is high (contact cabled between the common terminal "C" and the corresponding terminal "X1", "X2", or "X3" is closed)
- LED turned off: indicates that the corresponding inputs is low (contact cabled between the common terminal "C" and the corresponding terminal "X1", "X2", or "X3" is open)

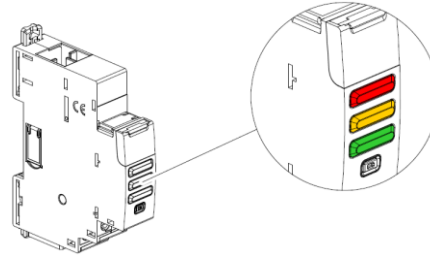

- . Technology : non replaceable LED lamps
- . Life time 100 000 hours without maintenance.
- . The ergonomic design of the translucent plastic window allows an homogeneous projection of the light.

Multi-Functions button:

. Front face button as several functions:

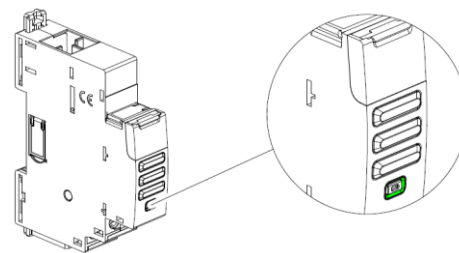

. Gives information about the operating state on the module
Possible states:

Led color	State	Meaning
red	Slow blinking	Error (e.g. addressing error)
	Fast blinking	No function
	Steady (pressing the multi function button longer than 20 sec.)	Total reset [any firmware updates are preserved]
green	Slow blinking	System process is running. Wait until the Led turns steady
	Fast blinking (pressing the multi function button for 10 sec.)	put in "Stand-by" the Nemo SX module (no remote action and communication available)
	Steady	System OK, connection is running
orange	Slow blinking	No function
	Fast blinking	Device's firmware update in progress
	Steady	No function

5. GENERAL CHARACTERISTICS *(continued)***Insulation voltage:**. $U_i = 400\text{ V}$ **Impulse withstand voltage U_{imp} :**

. Nemo SX ports / Input terminals:

. wave 1,2 / 50 μs : 6 kV

. alternate current 50 Hz / 1 min.: 3 kV

Pollution degree:

. 2 according to IEC/EN 60898-1.

Overvoltage category :

. III

Dielectric strength:

. 2500 V

Plastic material:

. Self-extinguishing polycarbonate.

. Heat and fire resistant according to IEC/EN 60695-2-12, glow-wire test at 960°C.

. Classification UL 94 / IECEN 60695-11-10: V1

Ambient operating temperature:

. Min. = -25°C. Max. = +70°C

Ambient storage temperature:

. Min. = -40°C. Max. = +70°C

Protection Index:

. Protection index of terminals against direct contacts:

IP2X (IEC/EN 60529).

. Protection index of terminals against solid and liquid bodies (wired device): IP 20 (IEC/EN 60529).

. Protection index of the front face against solid and liquid bodies: IP 40 (IEC/EN 60529).

. Class II, front panel with faceplate.

Average weight per device:

. 0,055 kg.

Volume when packed:. 0,21 dm³.**Consumption:**

. Values at 12 Vd.c.

Configuration	W	mA
Stand-by	0,258	21,5
All led OFF	0,258	21,5
1 led ON	0,298	24,8
2 led ON	0,337	28,1
All led ON	0,376	31,4

6. SYSTEM ARCHITECTURES

The Nemo SX is a polyvalent system and, according to the needs of the customer, can be set up and/or used as “Stand-alone” or “Supervised” system. Based on this choice the configuration and addressing methods are different.

Four possible architectures are provided:

6.1 Stand alone system

6.1.1 with local addressing (through the track wheel)

6.1.2 with remote addressing (through a computer)

6.2 Supervised (Computer Supervisory System)

6.2.1 with local addressing

6.2.2 with remote addressing

6.1 Stand-alone system

. **Stand alone** = autonomous system. To be used by the end-user if it is not necessary to have a computer for the supervision outside the envelope. Everything can be manage on site.

6.1.1 Stand-alone system with local addressing (through the track wheel)

Local addressing advantages:

- No configuration software needed to set-up the installation
- **It is not necessary to use a computer to manage settings** (configurations, test, ...) and to use the system (visualize and be alerted, ...). Everything can be done through the Mini configuration module (local display, cat. no SXV01). *[Refer to the technical sheet dedicated to this module for details].*
- No communication Interfaces or gateways are required.
- Installation can be done without the intervention of a System Integrator

Programming procedure:

. For Nemo SX modules which need some: mandatory through to lateral DIP-switch of each Nemo SX modules (see § "Module configuration" in the technical sheet of each device).

Addressing procedure:

. For all Nemo SX modules: mandatory through the track wheel located on the top upper face of each Nemo SX modules

. Marked from 0 to 9 in order to locally define the Modbus address of the Nemo SX modules

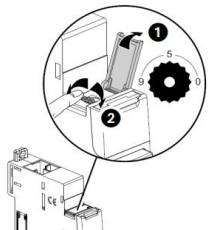

Consequences of the local addressing mode (through the track wheel):

- . Each device of the system must be addressed.
- . Addresses available: from 1 to 9
- . Address 0 not permitted
- . It is possible to assign to several devices the same address with the purpose of grouping different functions, **because they are related to the same electrical circuit**. For example it is possible to assign the same address to a multifunction signalling module (cat. no SXMC02), a multifunction control module (cat. no SXM0C1), a measuring module, and so on. In this way on the Nemo SX mini configuration module (local display) the grouped function will be displayed as a unique “device” with all grouped functions. *[Refer to the schemes hereunder]*

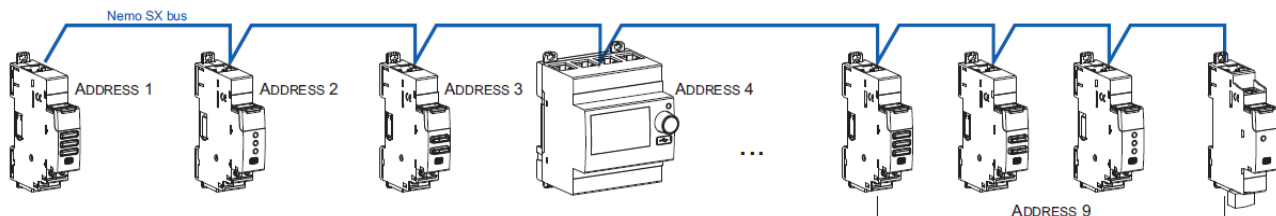

Note for the mini configuration module (local display)

- . It is possible to assign it the same address as another Nemo SX through the programming menu of the device
- . The mini configuration module can be placed everywhere in the Nemo SX bus

6. SYSTEM ARCHITECTURES

6.1 Stand-alone system (continued)

6.1.2 Stand-alone system with remote addressing (through a computer)

Remote addressing advantages:

- Whole configuration (addresses and functions) can be set up through the Nemo SX Configuration software
- Configuration software available for free
- **Automatic detection of the Nemo SX modules** installed in the system (characteristics, functions, configuration...)
- **Increased settings possibilities: load shedding function**
- Increased addressing: **up to 30 Modbus addresses in a system**

Programming procedure:

. For Nemo SX modules which need some: mandatory through to lateral DIP-switch of each Nemo SX modules (see § "Module configuration" in the technical sheet of each device).

Addressing procedure:

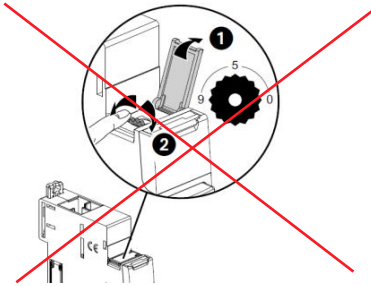

. It is not necessary to address the Nemo SX modules. The track wheel must be left in default position "0".

. All the addressing/configuring procedure will be done with the Configuration Software (available online for free)

. With remote addressing, the software does the automatic detection of modules installed in the system but the supervision is not possible until the user assign the remote address and all the characteristics to each module.

Note: it is mandatory to connect the computer to the mini configuration module with a "Type B" micro USB - USB cable. [For more details, refer to the technical sheet dedicated to this module].

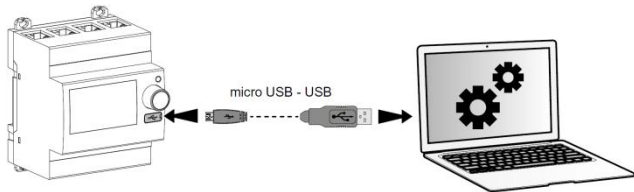

Read configuration from USB

Found:
7 modules
0 groups

Group modules in sets assigning the same address.
Press "Continue" to save addressing and import configuration.

Found modules				
Model	Module ID	Address	Result	
SXI485	EMS/RS485 interface	0000-0000-007E-125A	← 1 →	✓
SXMC02	State (contact+fault)	FFFF-FFFF-FFFF-FD9B	← 3 →	✓
SXMM53	Measure (singlephase 63A)	FFFF-FFFF-FFFF-FD68	← 2 →	✓
SXMM75	Measure (CT)	FFFF-FFFF-FFFF-FD71	← 4 →	✓
SXMDC1	Control (motor driven)	FFFF-FFFF-FFFF-FD61	← 2 →	✓
SXMT63	Measure (threephase 63A)	FFFF-FFFF-FFFF-FD6D	← 3 →	✓
SXMMIP	Measure (pulse)	FFFF-FFFF-FFFF-FD88	← 8 →	✓
SXMC02	State (contact+fault)	FFFF-FFFF-FFFF-FFFF	← 2 →	✓

Click on this icon on the table to make the LED blink on the corresponding module

6. SYSTEM ARCHITECTURES

6.1 Stand-alone system (continued):

6.1.2 Stand-alone system with remote addressing (through a computer) (continued):

Consequences for the system architecture:

- for 1 mini configuration module (cat. no SXV01)
 - o up to **30 Nemo SX modules** (eg. 30 devices grouped per functions with addresses from 1 to 30)

It is possible to assign to several devices the same address with the purpose of grouping different functions, **because they are related to the same electrical circuit**. For example it is possible to assign the same address to a multifunction signalling module (cat. no SXMC02), a multifunction control module (cat. no SXM0C1), a measuring module, and so on. In this way on the Nemo SX display or in a supervision system the grouped function will be displayed as a unique “device” with all grouped functions. [Refer to the schemes here under]

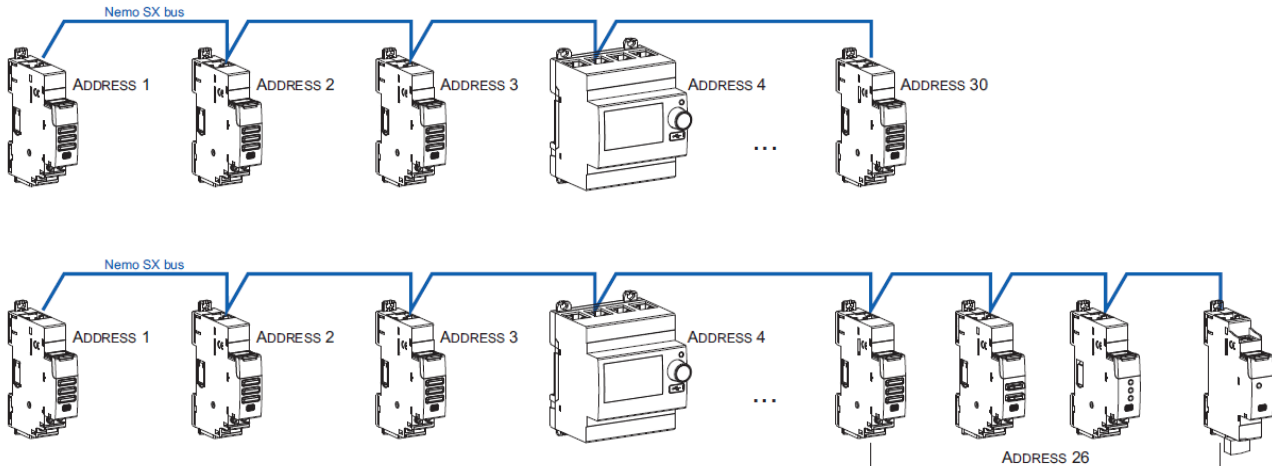

Note for the mini configuration module (local display)

- . It is possible to assign it the same address as another Nemo SX
- . The mini configuration module can be placed everywhere in the Nemo SX bus

6.2 Supervised system (Computer Supervisory System)

. **Supervised system** = System to be used through a Computer Supervisory System to remotely read data from the Nemo SX devices and/or do operations on these devices (e.g. commands of a motor driven or contactor ...).

6.2.1 Supervised system-with local addressing (through the track wheel)

Local addressing advantages:

- No configuration software needed to set-up the installation
- Installation can be done without the intervention of a System Integrator

Programming procedure:

. For Nemo SX modules which need some: mandatory through to lateral DIP-switch of each Nemo SX modules (see § "Module configuration" in the technical sheet of each device).

Addressing procedure:

- . For all Nemo SX modules: mandatory through the track wheel located on the top upper face of each Nemo SX modules
- . Marked from 0 to 9 in order to locally define the Modbus address to Nemo SX modules

In this system the Modbus address of an Nemo SX module device or group of modules (several functions) is obtained considering the address of the interface Modbus/Nemo SX Interface as tenth and the address of a device or group of function as unit (e.g. Interface address 1 = 10 → address of module n°5 = Modbus address 15)

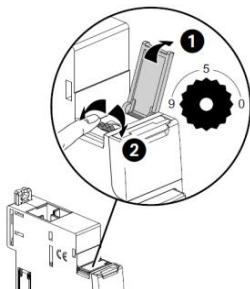

6. SYSTEM ARCHITECTURES *(continued)*

6.2 Supervised system (Computer Supervisory System) *(continued)*

6.2.1 Supervised system-with local addressing (through the track wheel) *(continued)*

Consequences of the local addressing mode (through the track wheel):

- . Each device of the system must be addressed.
- . Addresses available: from 1 to 9
- . Address 0 not permitted

It is possible to assign to several devices the same address with the purpose of grouping different functions, **because they are related to the same electrical circuit**. For example it is possible to assign the same address to a multifunction signalling module (cat. no SXMC02), a multifunction control module (cat. no SXM0C1), a measuring module, and so on. In this way on the Nemo SX display or in a supervision system the grouped function will be displayed as a unique “device” with all grouped functions. *[Refer to the scheme hereunder]*

Note: In this configuration the Modbus address of an Nemo SX module device or group of modules (several functions) is obtained considering the address of the interface Modbus/Nemo SX Interface as tenth and the address of a device or group of function as unit (e.g. Interface address 1 = 10 and device address = 5 → Modbus address = 15)

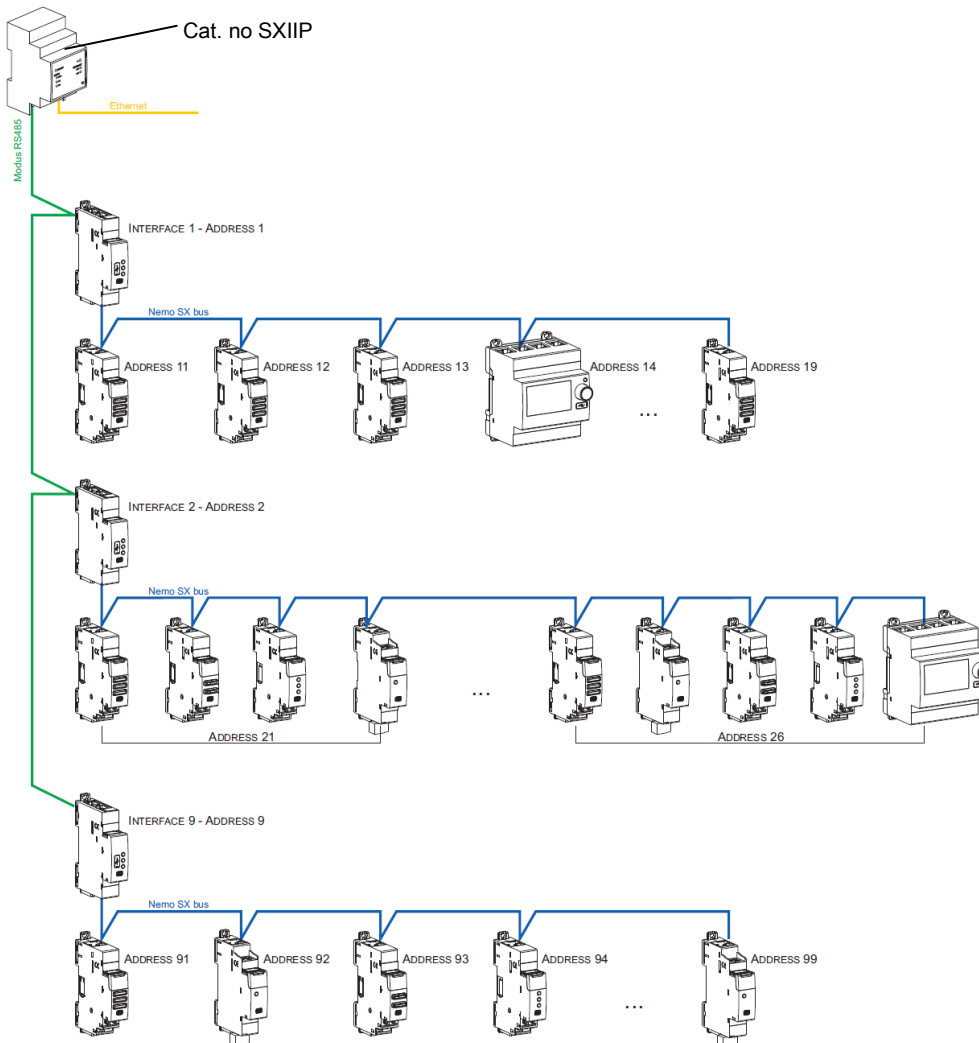

Consequences for the system architecture:

- for 1 IP/Modbus gateway (cat. no SXIIP):
 - o up to **81 Modbus address**
 - o mandatory limit of max. **9 Modbus/Nemo SX interfaces or max. 1000 m of Modbus cable** (cable Belden 9842, Belden 3106A or equivalent).
- for 1 Modbus/Nemo SX Interface (cat. no SXI485):
 - o up to **30 Nemo SX modules** (ex. 30 devices grouped per functions with addresses from 1 to 9)

Note: with local addressing, the Modbus/Nemo SX interface, does the automatic detection of modules (characteristics, functions, configuration...)

6. SYSTEM ARCHITECTURES (continued)

6.2 Supervised system (Computer Supervisory System) (continued)

6.2.2 Supervised system-with remote addressing (through a computer)

Remote addressing advantages:

- Whole of configuration (addresses and functions) can be done a remotely through the Nemo SX Configuration software
- Configuration software available for free
- **Automatic detection of the Nemo SX modules** installed in the system (characteristics, functions, configuration...)
- **Increased settings possibilities: load shedding function**
- Increased addressing: **up to 32 Modbus/Nemo SX interfaces**
- Increased addressing: **up to 247 Modbus addresses in a system**

Programming procedure:

. For Nemo SX modules which need some: mandatory through to lateral DIP-switch of each Nemo SX modules (see § "Module configuration" in the technical sheet of each device).

Note: via the configuration software it is possible to assign all the functions and characteristics of each Nemo SX module

Addressing procedure:

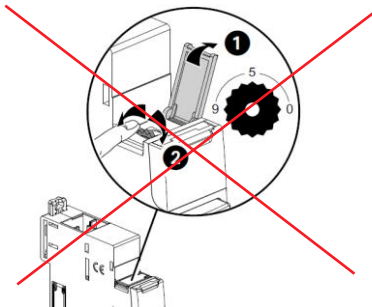

. It is not necessary to address the Nemo SX modules. The track wheel must be left in default position "0".

. A all the addressing/configuring procedure will be done with the Configuration Software (available online for free)

. With remote addressing, the software does the automatic detection of modules installed in the system but the supervision is not possible until the user assign the remote address and all the characteristics to each module.

Note: it is mandatory to connect the computer to the different Modbus/Nemo SX interface with a "Type B" micro USB - USB cable (one interface at a time). [For more details, refer to the technical sheet dedicated to this module].

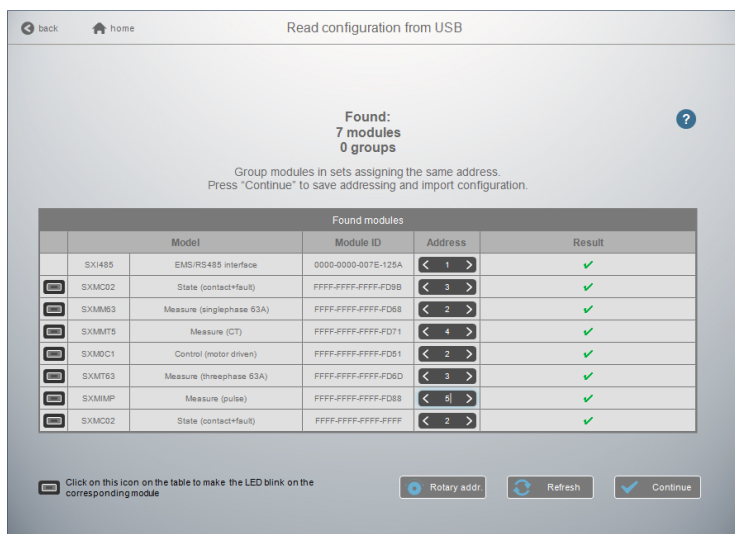
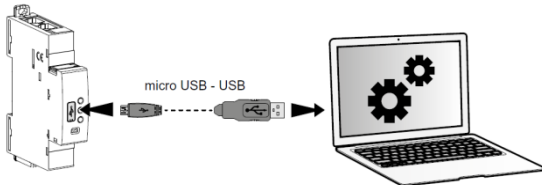

6. SYSTEM ARCHITECTURES (continued)

6.2 Supervised system (Computer Supervisory System) (continued)

6.2.2 Supervised system-with remote addressing (through a computer) (continued)

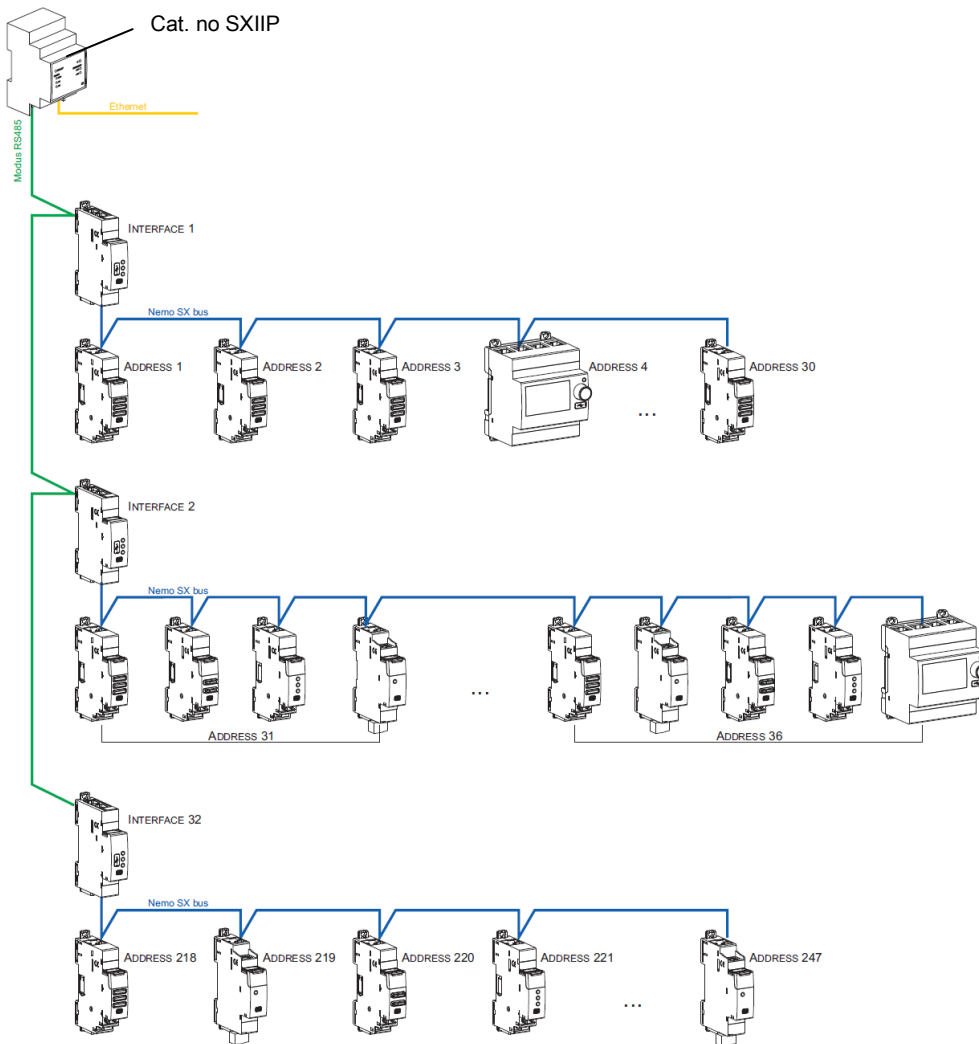

Consequences for the system architecture:

- for 1 IP/Modbus gateway (cat. no SXIIP):
 - o up to **247 Modbus address**
 - o Because of Modbus: mandatory limit of max. **32 Modbus/Nemo SX interfaces** or max. **1000 m of Modbus cable** (cable Belden 9842, Belden 3106A or equivalent).
- for 1 Modbus/Nemo SX Interface (cat. no SXI485):
 - o up to **30 Nemo SX modules or grouped modules** (e.g. 30 devices grouped per functions with addresses from 1 to 30)

It is possible to assign to several devices the same address with the purpose of grouping different functions, **because they are related to the same electrical circuit**. For example it is possible to assign the same address to a multifunction signalling module (cat. no SXMC02), a multifunction control module (cat. no SXM0C1), a measuring module, and so on. In this way on the Nemo SX display or in a supervision system the grouped function will be displayed as a unique “device” with all grouped functions. [Refer to the scheme up here]

7. COMPLIANCE AND APPROVALS

Compliance to standards:

- . Compliance with Directive on electromagnetic compatibility (EMC) n° 2014/30/EU
- . Compliance with low voltage directive n° 2014/35/EU.
- . Electromagnetic Compatibility:
 - IEC/EN 61131-2
 - IEC/EN 60947-5-1

Environment respect – Compliance with EU directives:

- . Compliance with Directive 2011/65/EU known as “RoHS 2” on the restriction of the use of certain hazardous substances in electrical and electronic equipment.
- . Compliance with REACH regulation: at the date of the publication of this document no substance from the candidate list is present in these products.

Plastic materials :

- . Halogens-free plastic materials.
- . Marking of parts according to ISO 11469 and ISO 1043.

Packaging :

- . Design and manufacture of packaging compliant to decree 98-638 of the 20/07/98 and also to directive 94/62/CE.