

Load Cells

Load cell accessories

SIWAREX EB extension boxes

Overview



The EB extension box is used to lengthen load cell connecting cables.

Load cells can be connected in 4-wire or 6-wire systems. The cable connection to the weighing module or to the JB junction box must always be implemented in 6-wire systems. The 7MH4 702-8AG or ...-8AF SIWAREX connection cable is recommended for this purpose.

If load cell cables are extended to a JB junction box, the M16 x 1.5 cable glands on the box must be replaced. The following is required for each load cell:

- 1 EMC cable gland M20 x 1.5
- 1 extension M16 x 1.5 male thread to M20 x 1.5 female thread.

Design

The EB extension box consists of a housing made of die-cast aluminum. It is protected against dust and spray water according to IP66. The cables are fed in through metric EMC cable glands and laid in spring-loaded terminals. A vibration-resistant and maintenance-free connection is achieved through the use of spring-loaded terminals.

For connecting load cells in a 4-wire system, two bridge elements are inserted for feedback of the sense signal.

Connection examples

Connecting one load cell

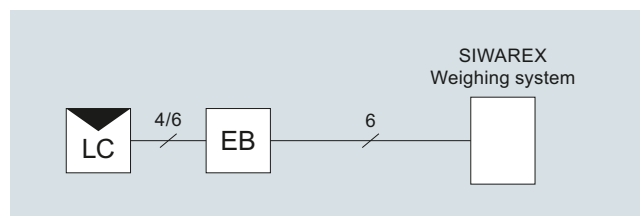

LC: Load cell

EB Extension box

Connecting multiple load cells

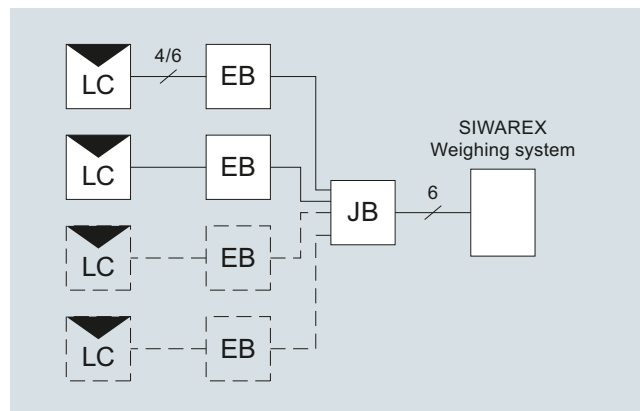

LC: Load cell

EB Extension box

JB: Junction box

Technical specifications

Cable glands

• Of load cell cable	M16 x 1.5
• Of signal cable	M20 x 1.5
Permissible ambient temperature	
• During operation	-30 ... +85 °C (-22 ... 185 °F)
• During operation for legal-for-trade medium accuracy weighing machines	-10 ... +40 °C (14 ... 104 °F)
• During transportation and storage	-40 ... +90 °C (-40 ... 194 °F)
Degree of protection acc. to EN 60529	IP66
Vibration resistance of terminals to DIN VDE 0611 11/77	12 Hz and 50 Hz, amplitude 1 mm
Insulation resistance of the terminals	≥ 10 ¹² Ω
Dimensions (W x H x D) in mm	80 x 75 x 57

Selection and ordering data

Article No.

Accessories

SIWAREX EB extension box, aluminum enclosure

For extending the connecting cable of load cells

Cable (optional)

Cable Li2Y 1 x 2 x 0.75 ST + 2 x (2 x 0.34 ST) – CY

For connecting SIWAREX electronic weighing systems to junction box (JB), extension box (EB) and Ex interface or between two extension boxes.

For permanent installation. Occasional bending is possible.

External diameter:
approx. 10.8 mm (0.43 inch)

Permissible ambient temperature
-40 ... +80 °C (-40 ... +176 °F)

Sold by the meter.

- Sheath color: orange
- For hazardous atmospheres. Sheath color: blue.

7MH4710-2AA

7MH4702-8AG

7MH4702-8AF

Dimensional drawings

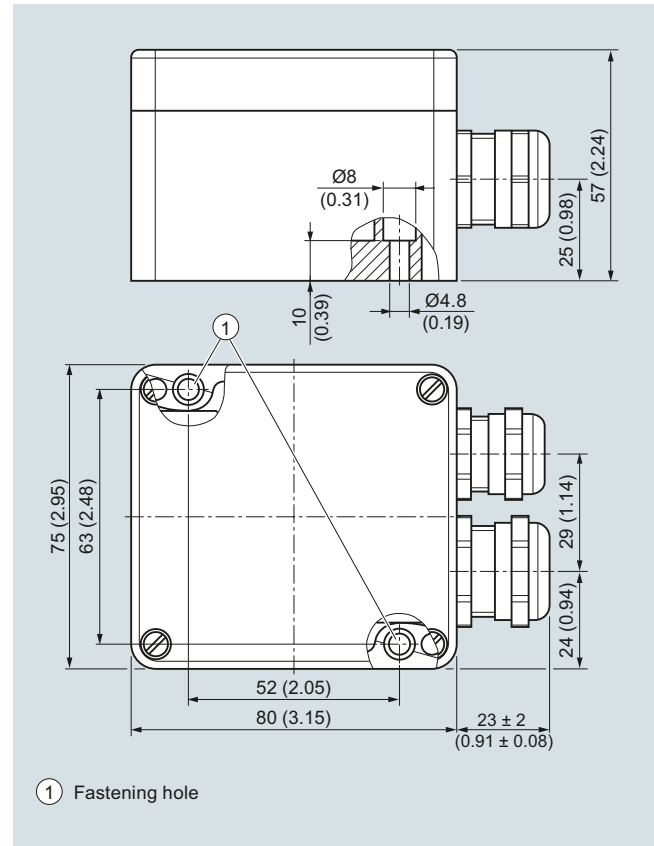

SIWAREX EB extension box (7MH4 710-2AA), dimensions in mm (inch)