

Extractive continuous process gas analysis

Series 6
 FIDAMAT 6

General information

1

Overview



The FIDAMAT 6 gas analyzer is suitable for the determination of the total hydrocarbon content in the air and high-boiling gas mixtures.

Benefits

The FIDAMAT 6 gas analyzer is distinguished by its wide range of applications:

- In the presence of up to 100 % H₂O vapor
- In ultra-pure gas applications
- With high-boiling components (up to 200 °C)
- In the presence of corrosive gases (with preliminary filter)

The FIDAMAT 6 exhibits:

- Extremely low cross-sensitivity to interfering gases
- Low consumption of combustion air
- Low influence of oxygen on measured value

The analyzer is additionally equipped with warning and fault messages:

- For failure of combustion gas
- If the flame is extinguished
- To indicate pump and filter faults

Application

Areas of application

- Environmental protection
- Wastewater (in conjunction with a stripping device, verification of the hydrocarbon content of liquids)
- TLV (Threshold Limit Value) monitoring at places of work
- Quality monitoring
- Process exhaust monitoring
- Ultra-pure gas measurements in media such as O₂, CO₂, inert gases and cold sample gases
- Measurement of corrosive and condensing gases
- Process optimization

Further applications

- Chemical plants
- Gas manufacturers (ultra-pure gas monitoring)
- Research and development
- Cement industry (measurement of emissions)
- Paint shops and dry-cleaning systems
- Refineries (tank farms, wastewater)
- Drying systems
- Solvent recovery systems
- Pharmaceutical industry
- Automotive industry (engine development, engine and transmission development and certification)

Special applications

Special applications

Special applications are available on request in addition to the standard combinations, e.g. measuring range 0 to 100 %.

Performance-tested version

Configuration prepared based on QAL1 according to EN 15267 for systems 13th BImSchV/27th BImSchV and TA Luft.

Design

- 19" slide-in module with 4 HU for installation
 - In hinged frame
 - In cabinets with or without telescopic rails
- Front plate can be swung down for servicing purposes (laptop connection)
- Gas connections for sample gas inlet and outlet as well as combustion gas and combustion air; pipe diameter 6 mm or 1/4"
- Gas and electrical connections at the rear
- Internal gas paths: stainless steel (mat. no. 1.4571)

Display and control panel

- Large LCD field for simultaneous display of
 - Measured value
 - Status bar
 - Measuring ranges
- Contrast of LCD panel adjustable using menu
- Permanent LED backlighting
- Washable membrane keyboard with five softkeys
- Menu-driven operation for parameterization, test functions, adjustment
- User help in plain text
- Graphic display of concentration trend; programmable time intervals

Input and outputs

- One analog output for each measured component
- Two programmable analog inputs
- Six digital inputs freely configurable (e.g. for measurement range switchover, processing of external signals from sample preparation)
- Six relay outputs freely configurable (failure, maintenance demanded, maintenance switch, limit alarm, external solenoid valves, measuring point switchover)
- Expansion by eight additional digital inputs and eight additional relay outputs for autocalibration with up to four calibration gases

Communication

RS 485 present in basic unit (connection from the rear).

Options

- RS 485/RS 232 converter
- RS 485/Ethernet converter
- RS 485/USB converter
- Incorporation in networks via PROFIBUS DP/PA interface
- SIPROM GA software as service and maintenance tool

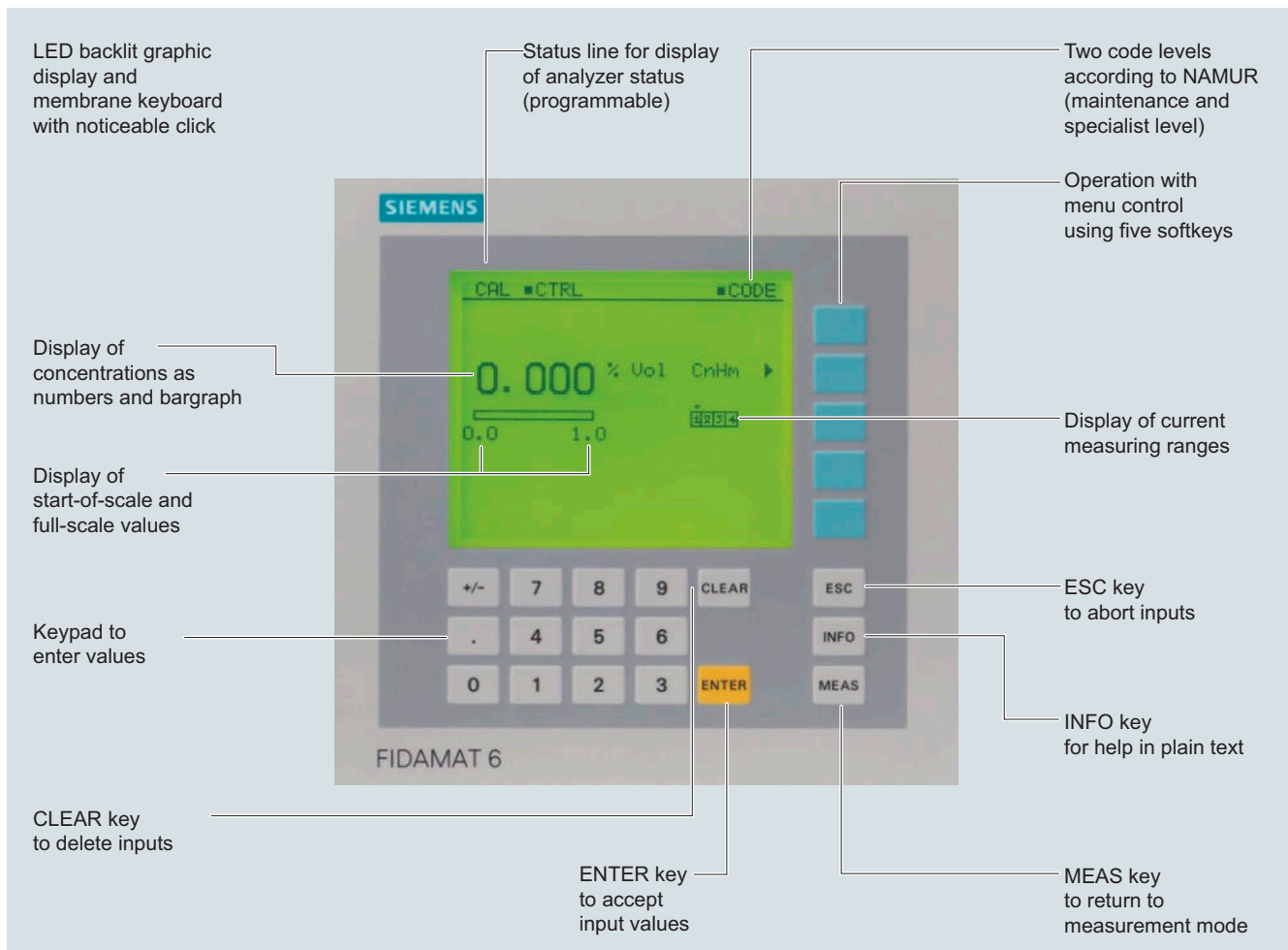

FIDAMAT 6, membrane keyboard and graphic display

Extractive continuous process gas analysis

Series 6

FIDAMAT 6

General information

Designs – parts wetted by sample gas

Gas path	Material
Piping	Stainless steel, mat. no. 1.4571
Gas inlet	Stainless steel, mat. no. 1.4571
Gaskets	Graphite
Sample gas restrictor	Quartz
Auxiliary gas restrictors	Stainless steel, mat. no. 1.4571
Pump membrane	PTFE
Pump head	Stainless steel, mat. no. 1.4571
Detector	
• Nozzle	Quartz
• FID housing	Stainless steel, mat. no. 1.4571

Gas path

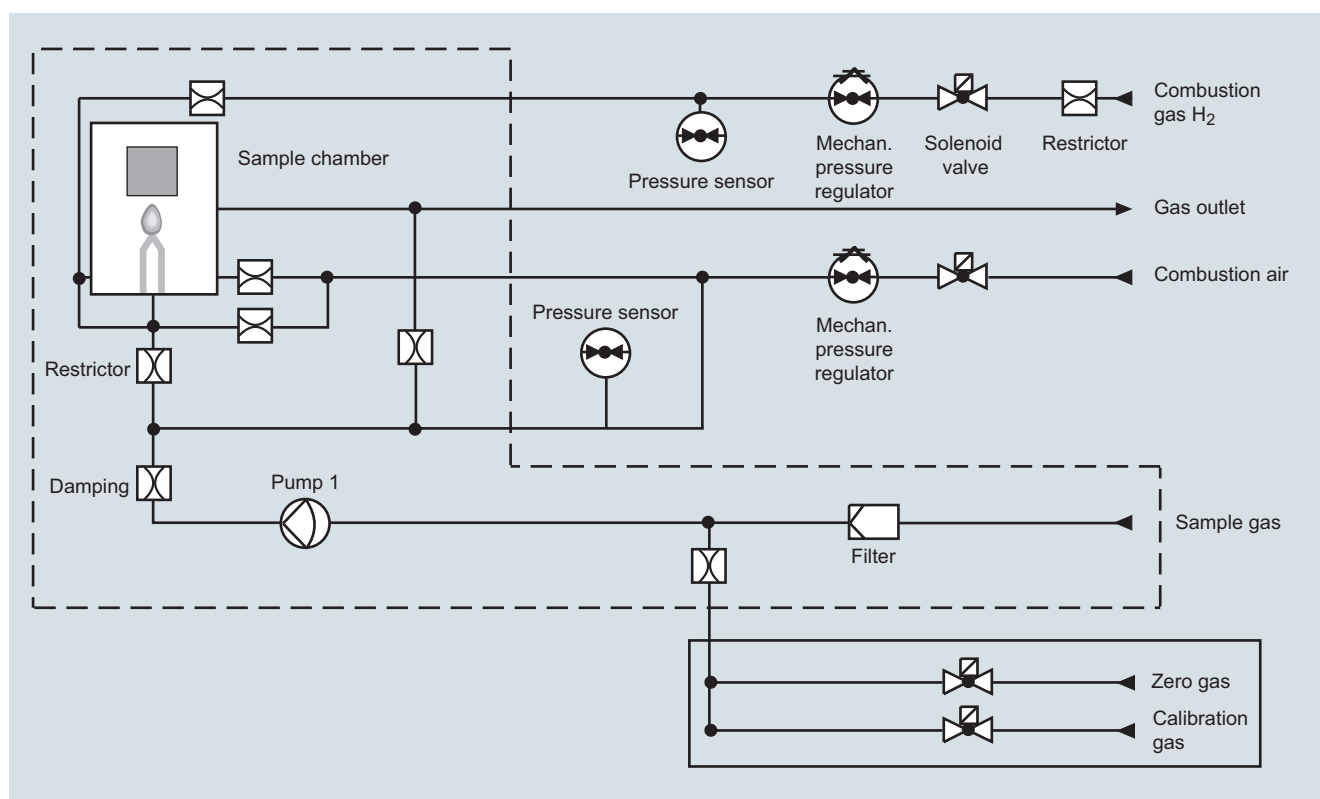

FIDAMAT 6 total hydrocarbon analyzer, gas path with pump and with connection for combustion air

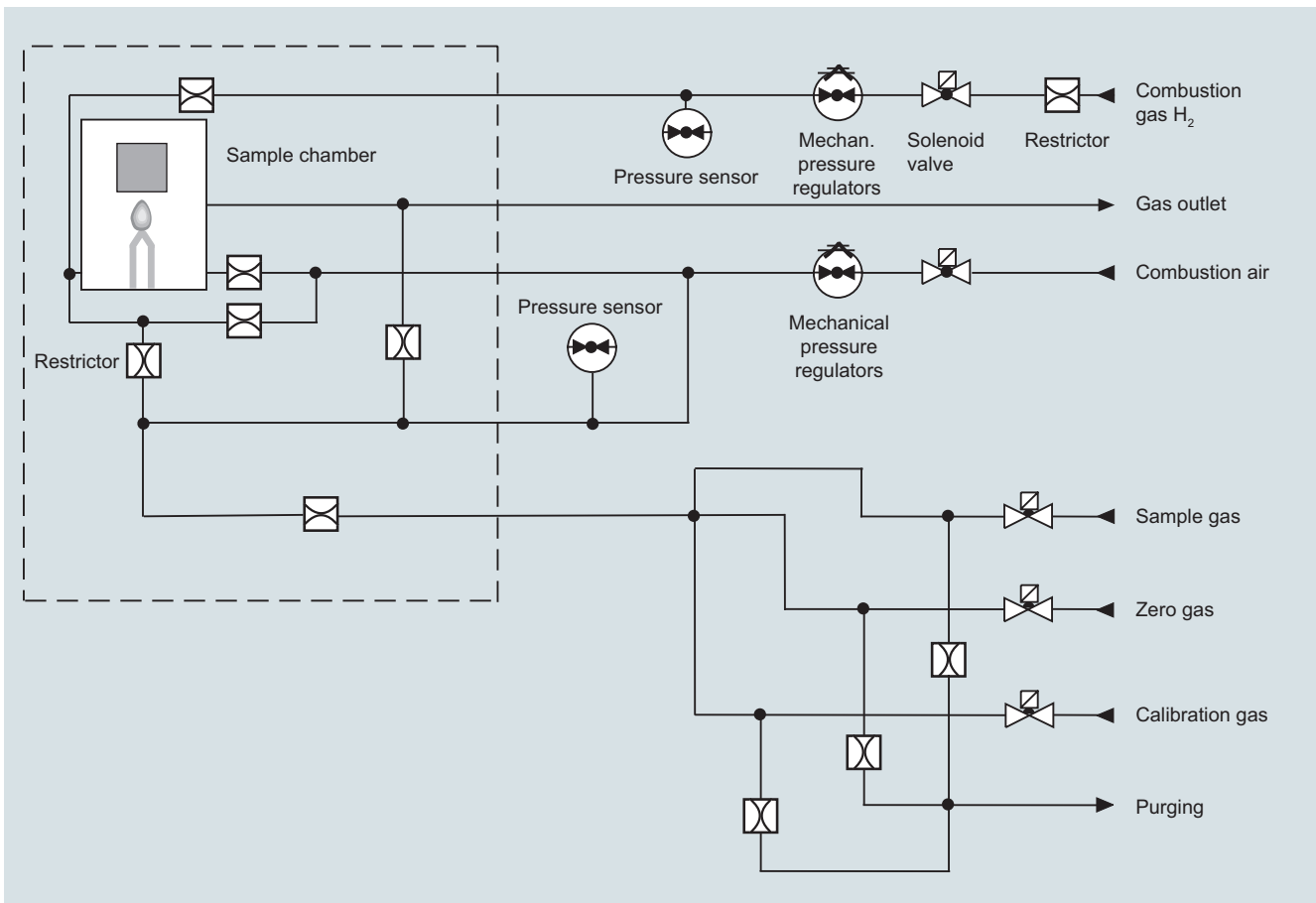

FIDAMAT 6 total hydrocarbon analyzer, gas path without pump and with connection for combustion air

Extractive continuous process gas analysis

Series 6

FIDAMAT 6

General information

Function

Principle of operation

The FIDAMAT 6 carries out substance-specific measurements and not component-specific measurements. It measures the total of all hydrocarbons in a sample gas, but with different weighting of the hydrocarbon molecules. To a first approximation, the display is proportional to the number of C atoms in the respective molecule. However, there are fluctuations in practice. The display deviation for the respective molecule is expressed by the response factor.

The sample gas is supplied to the FIDAMAT 6 through overpressure or drawn in by the built-in diaphragm pump (optionally via a heated line and an additional filter) and passed on to the flame ionization detector via an obstruction-proof fused-silica restrictor.

In the detector, the hydrocarbons in the sample gas are burned in an oxyhydrogen gas flame. Burning partially ionizes the proportion of organically-bound hydrocarbons. The released ions are converted into an ionic current by the voltage present between two electrodes, and measured using a highly sensitive amplifier. The current measured is proportional to the quantity of organically-bound C atoms in the sample gas.

A pressure regulator keeps the combustion gas pressure constant. The balanced system of pump, capillary tubes, and pressure regulator for combustion air ensures that the sample gas pressure is kept constant.

When the analyzer is switched on, ignition is carried out automatically when the setpoint temperature has been reached and, for versions "with pump", the pump is also started up.

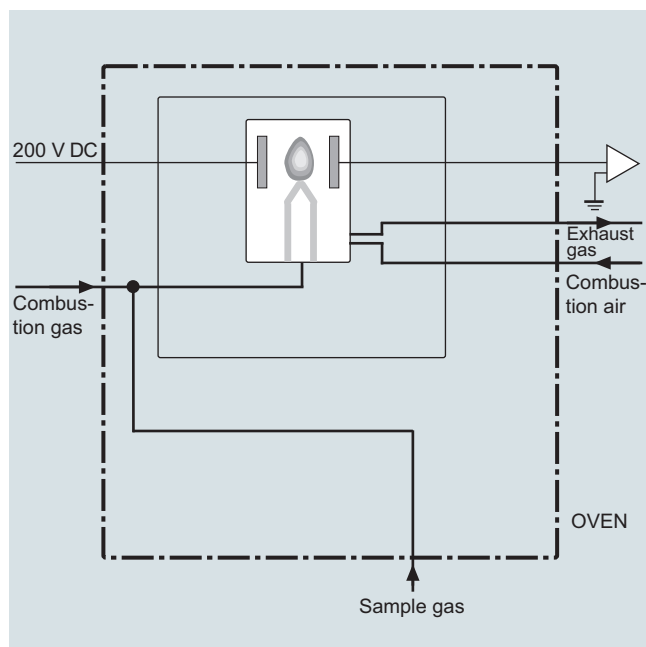

FIDAMAT 6, principle of operation

The FIDAMAT 6 provides various messages in the form of floating contacts:

- Maintenance request
E.g. sample gas flow (filter/pump)
Fan failure (advance warning for measuring accuracy)
The measured value remains unaffected.
- Fault
e. g., hydrogen, combustion air and sample gas pressures, temperature, analyzer part and pump, fault in the electronics (temperature).
The measured value may be influenced.
- Failure
In the event of failure of, for example, the electronics, power supply, combustion gas, combustion air or sample gas, the analyzer automatically shuts down (the combustion gas valve is closed).

Note

The sample gases must be fed into the analyzers free of dust. Condensation should be avoided. Therefore, the use of gas modified for the measuring task is necessary in most application cases.

Calibration

The calibrating interval should be adapted to the respective measuring task. We recommend N_2 as zero gas (at least 5.0; for measuring of hydrocarbons < 1 vpm: at least 6.0).

The calibration gas should have a concentration of at least 60 % of the leading measuring range. The concentration of residual hydrocarbons must not exceed 0.1 vpm.

For pure gas measurement, use suitable additional gases.

Example:

1. Emission measurement

Measuring range	0 ... 50 mg C/m ³
Zero gas	N ₂ (5.0 or better)
Calibration gas	21 vpm C ₃ H ₈ in N ₂ (corresponds to 31.43 mg C/m ³ at 20 °C)

2. Purity measurement in 100 % O₂

Measuring range	0 ... 50 vpm C ₁
Zero gas	N ₂ (5.0 or better)
Calibration gas	At least 30 vpm CH ₄ in O ₂

Essential characteristics

- Four measuring ranges which can be freely configured, even with suppressed zero point, all measuring ranges are linear
- Galvanically isolated measured-value output 0/2/4 to 20 mA (also inverted)
- Autoranging possible; remote switching is also possible
- Storage of measured values possible during adjustments
- Measuring range identification
- Measuring point switchover for up to 6 measuring points
- Measuring point identification
- Wide range of selectable time constants (static/dynamic noise suppression); i.e. the response time of the device can be adapted to the respective measuring task
- Easy handling thanks to menu-driven operation
- Low long-term drift
- Two control levels with their own authorization codes for the prevention of accidental and unauthorized operator interventions
- Automatic measuring range calibration can be configured
- Operation based on the NAMUR recommendation
- Customer-specific analyzer options such as:
 - Customer acceptance
 - TAG labels
 - Drift recording
- Wear-free, corrosion-proof filter housing
- No blocking of the sample gas capillaries through the use of a quartz restrictor
- Purge function in the event of analyzer or power supply failure (avoids build-up of toxic and corrosive substances in the device)
- Low consumption of combustion air
- Response factors comply with the minimum requirements in accordance with German air purity guidelines and the Working Group of the German automotive Industry
- Simple handling using a numerical membrane keyboard and operator prompting

Response factors (examples, mean values)

Substance	Mean response factor
n-butane	1.00
n-propane	1.00
n-heptane	1.00
Cyclohexane	1.08
Isopropanol	0.81
Toluene	1.06
Acetone	0.92
Ethyl acetate	0.76
Isobutyl acetate	0.83
Methane	1.06
Ethane	0.99
n-hexane	1.01
iso-octane	1.04
Ethine (acetylene)	0.91
Propene	0.84
Methanol	0.87
Ethanol	0.83
Ethanoic acid	1.13
Methyl acetate	0.67
Benzene	1.01
Ethyl benzene	0.96
p-xylene	1.03
Dichloromethane	1.13
Trichloroethene	1.01
Tetrachlorethene	1.07
Chloroform	0.72
Chlorobenzene	1.15

Cross-interferences (examples)¹⁾

Interfering component	Concentration of the interfering component	Induced cross-interference
O ₂ in N ₂	(21 vol. %)	< 0.3 mg/m ³
SO ₂ in N ₂	(258 mg/m ³)	< 0.15 mg/m ³
NO in N ₂	(310 mg/m ³)	< 0.5 mg/m ³
NO ₂ in synth. Air	(146 mg/m ³)	< 0.1 mg/m ³
CO in N ₂	(461 mg/m ³)	< 0.15 mg/m ³
CO ₂ in N ₂	(18 vol. %)	< 0.1 mg/m ³
HCl in N ₂	(78 mg/m ³)	< 0.3 mg/m ³

¹⁾ With measuring range 0 to 15 mg/m³.

Extractive continuous process gas analysis

Series 6

FIDAMAT 6

19" rack unit

1

Technical specifications

General information		Measuring response	
Measuring ranges	4, internally and externally switchable; manual and autoranging possible	Output signal fluctuation	Based on sample gas pressure 1 013 hPa absolute, 0.5 l/min sample gas flow and 25 °C ambient temperature < 0.75% of the smallest possible measuring range according to rating plate, with electronic damping constant of 1 s (corresponds to $\pm 0.25\%$ at 2σ)
Smallest possible measuring span	0 ... 10 vpm	Zero point drift	< 0.5%/month of the smallest possible measuring span according to rating plate
Largest possible measuring span	99.999 vpm ^{*)}	Measured-value drift	< 1%/week of the current measuring range
Concentration units	vpm, C ₁ , C ₃ , C ₆ or mgC/m ³	Repeatability	< 1% of the current measuring range
Autoranging	Hysteresis, selectable	Detection limit	0.1 vpm (version for ultra-pure gas measurement: 50 ppb)
Measured-value display	Digital concentration display (5 digits with floating point)	Linearity error	< 1% of the current measuring range
Resolution of digital display	0.1% of measured value	Influencing variables	
Operating position	Front wall, vertical	Ambient temperature	Based on sample gas pressure 1 013 hPa absolute, 0.5 l/min sample gas flow and 25 °C ambient temperature < 1%/10 K referred to smallest possible span according to rating plate
Conformity	CE mark in accordance with EN 50081-1, EN 50082-2	Atmospheric pressure	< 1%/50 hPa
Oven temperature	Adjustable, 100 ... 200 °C	Sample gas pressure	< 2% of the current measuring range/ 1% pressure change (within 600 ... 1 100 hPa)
Design, enclosure		Auxiliary power	< 1% of the current measuring range with rated voltage $\pm 10\%$
Degree of protection	IP20 according to EN 60529	Position influence	< 1% with < 15° inclination
Weight	Approx. 23 kg	Electrical inputs and outputs	
Electrical characteristics		Analog output	0/2/4 ... 20 mA, isolated; max. load 750 Ω
Auxiliary power	100 ... 120 V AC (nominal range of use 90 ... 132 V), 48 ... 63 Hz or 200 ... 240 V AC (nominal range of use 180 ... 264 V), 48 ... 63 Hz	Relay outputs	6, with changeover contacts, freely configurable, e.g. for measuring range identification; load: 24 V AC/DC/1 A, potential-free
Power consumption	<ul style="list-style-type: none"> • Approx. 150 VA during operation, • Approx. 350 VA during warm-up phase 	Analog inputs	2, dimensioned for 0/2/4 to 20 mA for external pressure sensor and correction of influence of accompanying gas (correction of cross-interference)
EMC interference immunity (electromagnetic compatibility)	In accordance with standard requirements of NAMUR NE21 (08/98)	Digital inputs	6, designed for 24 V, floating, freely configurable, e.g. for measuring range switchover
Electrical safety	In accordance with EN 61010-1, overvoltage category II	Serial interface	RS 485
Fuse values	<ul style="list-style-type: none"> • 100 ... 120 V: 4.0T/250 • 200 ... 240 V: 2.5 T/250 	Options	AUTOCAL function each with 8 additional digital inputs and relay outputs, also with PROFIBUS PA or PROFIBUS DP
Gas inlet conditions		Climatic conditions	
Permissible sample gas pressure	< 2 000 hPa abs.	Permissible ambient temperature	5 ... 45 °C in operation, -30 ... +70 °C during storage and transportation
<ul style="list-style-type: none"> • Without pump • With integrated pump 	600 ... 1 100 hPa	Permissible humidity	< 90% RH (RH: relative humidity) as annual average, during storage and transportation (must not fall below dew point)
Sample gas temperature	0 ... 200 °C		
Sample gas humidity	< 90% RH (RH: relative humidity)		
Dynamic response			
Warm-up period	At room temperature, approx. 2 ... 3 h		
Delayed display (T ₉₀)	2 ... 3 s		
Damping (electrical time constant)	0 ... 100 s, configurable		
Dead time (purging time of the gas path in the unit at 1 l/min)	With filter, 2 ... 3 s		
Time for device-internal signal processing	< 1 s		

*) 100% as special application

FIDAMAT 6 with pump and heated oven, with combustion air connection

Gases	Inlet pressure hPa (abs.)	Operating pressure		Flow through FID ml/min	Flow through bypass ml/min
		Pump startup			
		Without hPa (abs.)	With hPa (abs.)		
Combustion gas	3 000 ... 5 000	2 000 ± 20		~ 25	—
Combustion air	3 000 ... 5 000	1 420 ± 20	1 500	~ 320	~ 500
Sample gas	~ 1000	—	1 500 ± 2	~ 3	~ 1 000
Zero gas	3 500 ... 4 000	—	1 500 ± 2	~ 3	~ 1 000
Calibration gas	3 500 ... 4 000	—	1 500 ± 2	~ 3	~ 1 000

FIDAMAT 6 without pump, with heated oven, with combustion air connection

Gases	Inlet pressure hPa (abs.)	Operating pressure		Flow through FID ml/min	Flow through bypass ml/min
		Sample/calibration gas			
		Without hPa (abs.)	With hPa (abs.)		
Combustion gas	3 000 ... 5 000	2 000 ± 20		~ 25	—
Combustion air	3 000 ... 5 000	1 480 ± 5	—	~ 320	~ 300
Sample gas	1 500 ... 2 000	—	1 500 ± 2	~ 3	~ 500
Zero gas	1 500 ... 2 000	—	1 500 ± 2	~ 3	~ 500
Calibration gas	1 500 ... 2 000	—	1 500 ± 2	~ 3	~ 500

The supply gases (combustion gas, combustion air) must have a degree of purity of 5.0 in order to guarantee correct measurements. The degree of purity must be increased in the case of very small hydrocarbon concentrations (< 1 ppm).

Extractive continuous process gas analysis

Series 6

FIDAMAT 6

19" rack unit

1

Selection and ordering data

FIDAMAT 6 gas analyzer

19" rack unit for installation in cabinets

➤ Click on the Article No. for the online configuration in the PIA Life Cycle Portal.

Gas connections

Pipe with 6 mm outer diameter

Pipe with 1/4" outer diameter

Version

Without pump, for sample gas with overpressure¹⁾

With heated pump, for sample gas with atm. pressure

Combustion air feed

With connection for combustion air

Number of channels

1-channel version

Add-on electronics

Without

AUTOCAL function

- With 8 additional digital inputs/outputs
- With 8 digital inputs/8 digital outputs, PROFIBUS PA interface
- With 8 digital inputs/8 digital outputs, PROFIBUS DP interface

Power supply

100 ... 120 V AC, 48 ... 63 Hz

200 ... 240 V AC, 48 ... 63 Hz

Combustion gases

H₂

Language (supplied documentation, software)

German

English

French

Spanish

Italian

Article No.

➤ 7MB2421- - - - - A

0

1

B

D

A

1

0

1

6

7

0

1

A

0

1

2

3

4

Additional versions

Order code

Add "-Z" to Article No. and specify Order code

Telescopic rails (2 units)

A31

TAG labels (specific lettering based on customer information)

B03

Clean for O₂ service (specially cleaned gas path)

Y02

Measuring range indication in plain text, if different from the standard setting

Y11

Special setting (only in conjunction with an application No.)

Y12

Extended special setting (only in conjunction with an application No.)

Y13

Configuration according to EN 14181:2004

Y17

Prepared for EN 15267:2015²⁾

Y27

Accessories

Article No.

RS 485/Ethernet converter

A5E00852383

RS 485/RS 232 converter

C79451-Z1589-U1

RS 485/USB converter

A5E00852382

AUTOCAL function each with 8 digital inputs/outputs

C79451-A3480-D511

AUTOCAL function 8 digital inputs/outputs each and PROFIBUS PA

A5E00057307

AUTOCAL function 8 digital inputs/outputs each and PROFIBUS DP

A5E00057312

Set of Torx screwdrivers

A5E34821625

¹⁾ No QAL1 certification according to EN 15267

²⁾ For certified operation, compensation of the cross-interference caused by the oxygen is required. To do this, the device must be supplied with the current oxygen concentration value of the sample gas. The supply takes place over an external measuring instrument that must also meet the requirements of EN 15267-3 (e.g. ULTRAMAT 23 or OXYMAT 6). The FIDAMAT 6E -Y27 is preconfigured accordingly and expects an analog signal of 4 ... 20 mA corresponding to 0 ... 21 vol % O₂ at analog input AI2.

Dimensional drawings

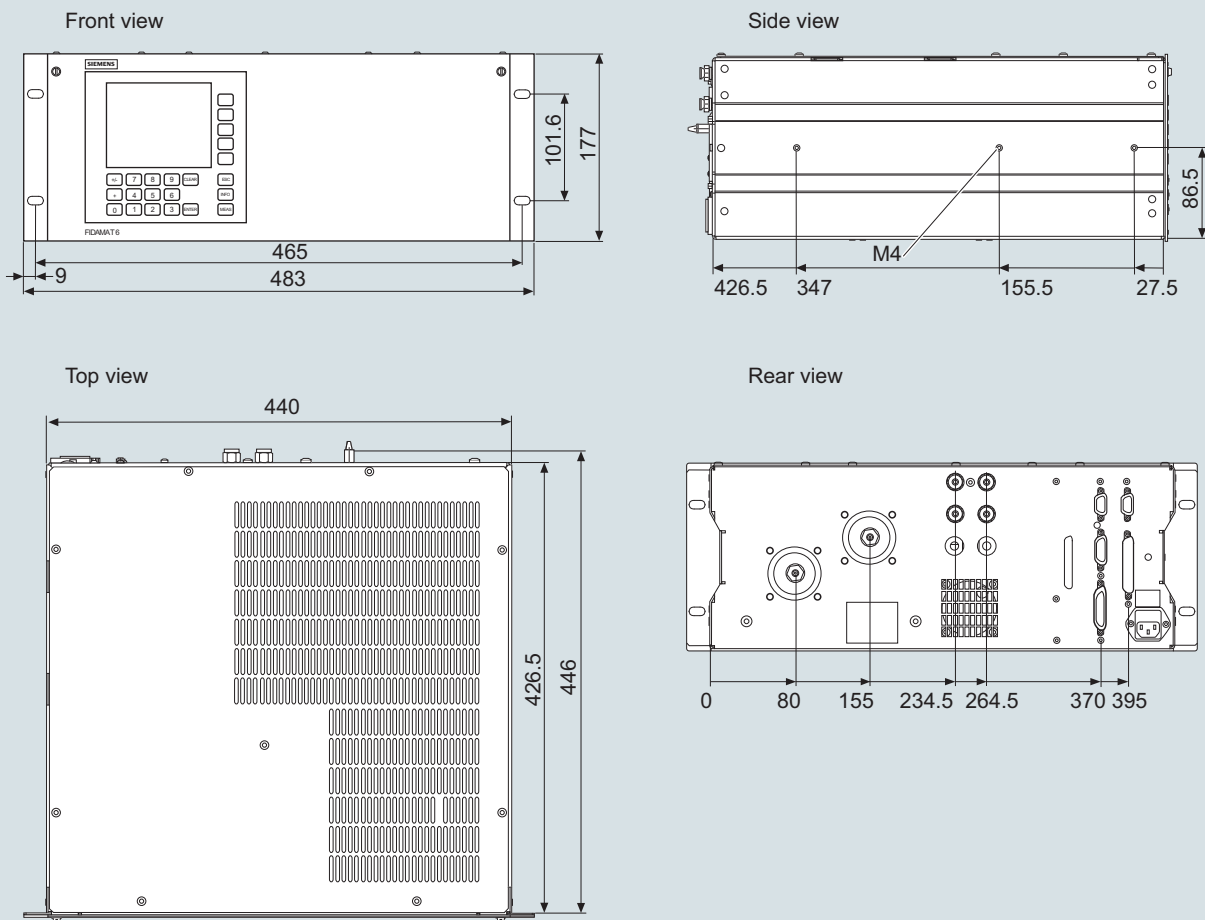

FIDAMAT 6, 19" unit, dimensions in mm

Extractive continuous process gas analysis

Series 6
FIDAMAT 6

19" rack unit

Circuit diagrams

Pin assignment (electrical and gas connections)

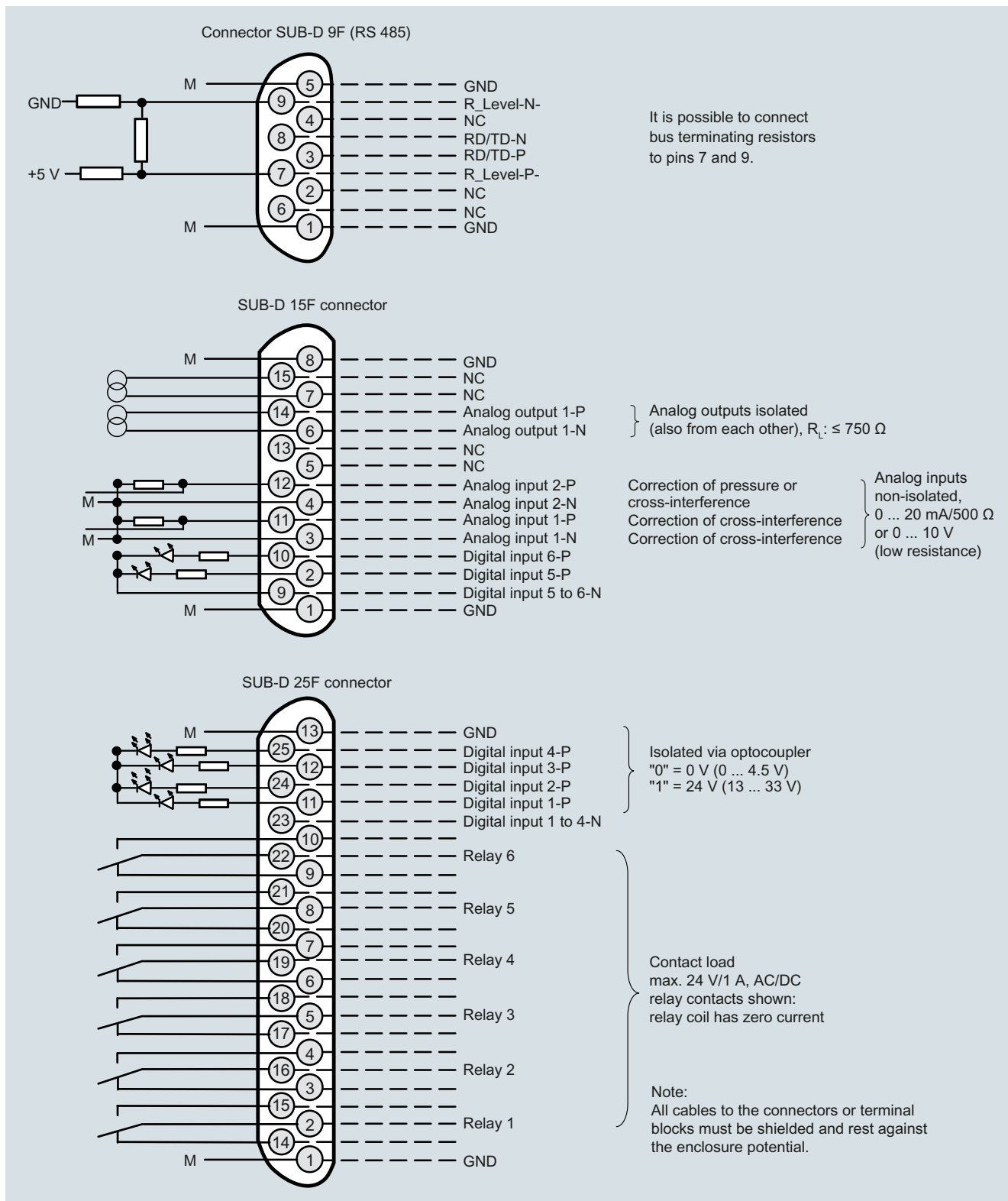

FIDAMAT 6, 19" rack unit, pin assignment

Extractive continuous process gas analysis

Series 6
FIDAMAT 6

19" rack unit

1

Connector SUB-D 37F (option)

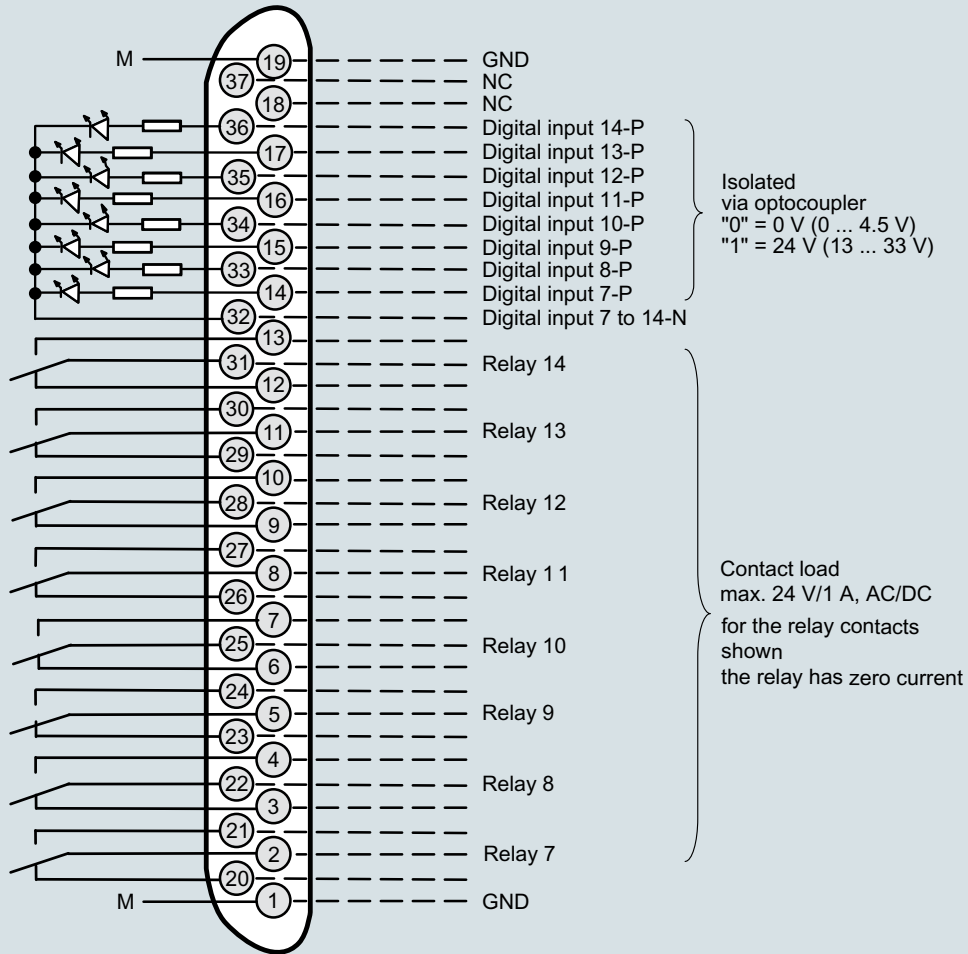

Connector SUB-D 9F
PROFIBUS DP

optional

Connector SUB-D 9M
PROFIBUS PA

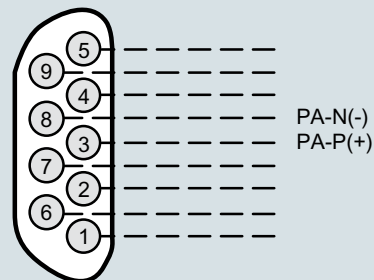
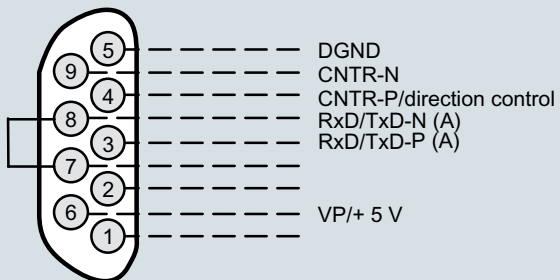

Note:
All cables to the connectors or terminal blocks must be shielded and rest against the enclosure potential.

FIDAMAT 6, 19" rack unit, pin assignment of the AUTOCAL board and PROFIBUS connectors

Extractive continuous process gas analysis

Series 6
FIDAMAT 6

19" rack unit

1

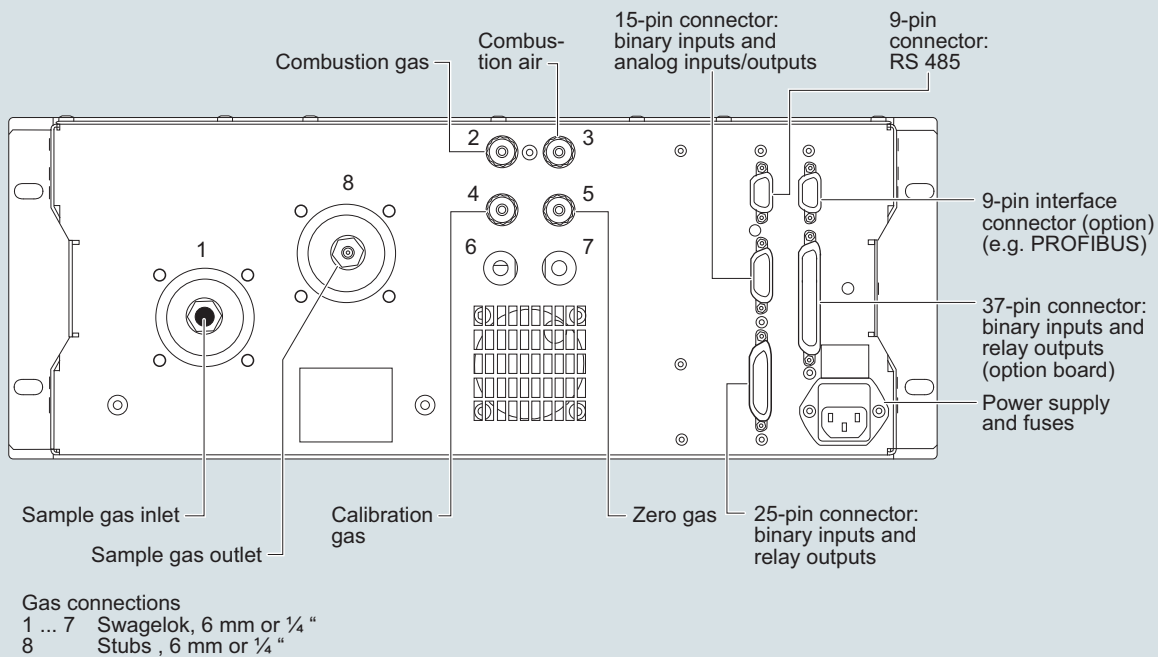

FIDAMAT 6, gas connections and pin assignment, version with pump

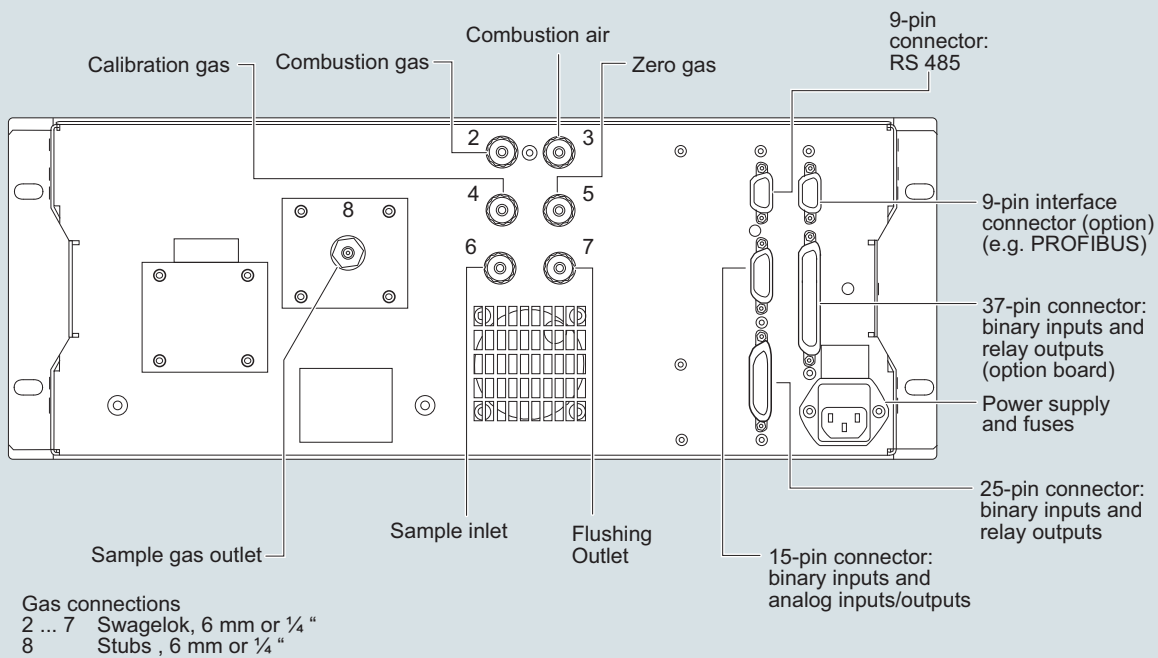

FIDAMAT 6, gas connections and pin assignment, version without pump

Selection and ordering data

Operating instructions	Article No.
FIDAMAT 6 Gas analyzer for determination of total hydrocarbon concentration	
• German	A5E00221703
• English	A5E00222135
• French	A5E00222138
• Spanish	A5E00222141
• Italian	A5E00222144
FIDAMAT 6-G Gas analyzer for determination of total hydrocarbon content	
• German	A5E00476038

More information

The complete documentation is available in various languages for downloading free of charge:
<http://www.siemens.com/processanalytics/documentation>

Extractive continuous process gas analysis

Series 6

FIDAMAT 6

Suggestions for spare parts

1

Selection and ordering data

Description			Article No. FIDAMAT 6	
	2 years (quantity)	5 years (quantity)	With pump	Without pump
Analyzer unit				
FI detector, complete		1	A5E00295816	A5E00295816
Sample gas path				
Pump (KNF)	1	1	A5E00882121	
Set of gaskets for pump (KNF)	4	10	A5E03792459	
Filter, with gasket for sample gas	1	3	A5E00248845	
Pressure regulators	1	1	A5E00248851	A5E00248851
Gasket for pressure regulator	1	2	A5E00295107	A5E00295107
Filter, complete (sample gas inlet, 6 mm)		1	A5E00295928	
Filter, complete (sample gas inlet, ¼")		1	A5E00295976	
Solenoid valve (1-way)	1	2	A5E00296562	A5E00296562
Solenoid valve (2-way)	1	2	A5E00296565	
Gasket, PTFE, 1.5 mm (20 units)	1	2	C79451-A3040-D101	C79451-A3040-D101
Gasket, graphite, 0.5 to 1 mm (20 units)	1	2	C79451-A3040-D102	C79451-A3040-D102
Gasket, graphite, 1.5 mm (20 units)	1	2	C79451-A3040-D103	C79451-A3040-D103
Gasket, graphite, 3 mm (20 units)	1	2	C79451-A3040-D105	C79451-A3040-D105
Pressure ring, 1 mm (20 units)		1	C79451-A3040-D112	C79451-A3040-D112
Pressure ring, 1.5 mm (20 units)		1	C79451-A3040-D113	C79451-A3040-D113
Pressure ring, 3 mm (20 units)		1	C79451-A3040-D115	C79451-A3040-D115
Outer rings, 0.5 ... 1 mm (20 units)		1	C79451-A3040-D121	C79451-A3040-D121
Outer rings, 1.5 ... 3 mm (1/8") (20 units)		1	C79451-A3040-D122	C79451-A3040-D122
Electronics				
Front plate	1	1	A5E00248790	A5E00248790
Adapter plate	1	1	A5E00248795	A5E00248795
Temperature fuse (retrofitting set)	1	2	A5E01040317	A5E01040317
Fusible element, 230 V AC	2	3	A5E00248819	A5E00248819
Fusible element, 110 V AC	2	3	A5E00248822	A5E00248822
LC display	1	1	A5E00248920	A5E00248920
Cable, temperature sensor for oven		1	A5E00283770	A5E00283770
Cable, temperature sensor for analyzer part		1	A5E00283780	A5E00283780
Cable, magnetic distributor		1	A5E00283800	A5E00283800
Cable, heater for oven, 230 V AC		1	A5E00283817	A5E00283817
Cable, heater for oven, 110 V AC		1	A5E00295469	A5E00295469
Cable, electrode voltage, complete		1	A5E00284092	A5E00284092
Cable, signal cable		1	A5E00284094	A5E00284094
Cable, connecting cable (4-pole)	1	1	A5E00284095	A5E00284095
Cable, connecting cable (5-pole)	1	1	A5E00284096	A5E00284096
Axial-flow fan, 24 V DC		1	A5E00313839	A5E00313839

If the device was supplied with a specially cleaned gas path for high oxygen context ("Clean for O₂ service"), please ensure that you specify this when ordering spare parts. This is the only way to guarantee that the gas path will continue to comply with the special requirements for this version.