

## Overview

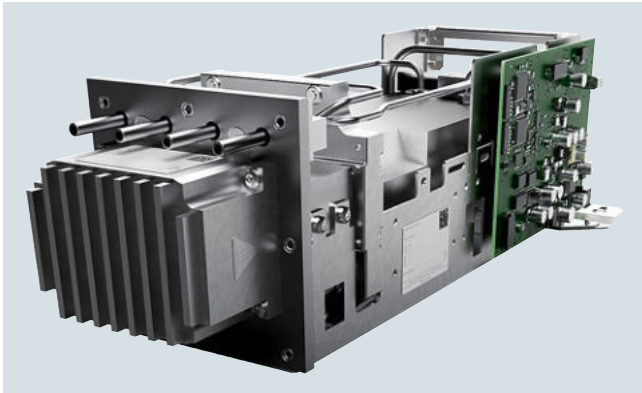

The ULTRAMAT 7 module functions according to the NDIR dual-beam differential mode process and measures gases whose absorption bands in the infrared wavelength range are between 2 and 9  $\mu\text{m}$ , such as CO, CO<sub>2</sub>, CH<sub>4</sub>, SO<sub>2</sub> or NO. Up to two components can be measured per module.

## Benefits

- High selectivity due to double-layer detector
- Reliable measurements even in complex gas mixtures
- Low detection limits
- Measurements with low concentrations
- Analyzer cells can be cleaned as required on site
- Cost savings due to reuse after contamination
- Corrosion-resistant materials in gas path (option)
- Measurement of highly corrosive gases possible

## Application

### Application areas

- Measurement for boiler control in incineration plants
- Process gas concentrations in chemical plants
- Trace measurements in pure gas processes
- Environmental protection
- TLV (Threshold Limit Value) monitoring at the workplace
- Quality monitoring
- introduction of flammable gases possible

### Special versions

#### Flow-type reference compartment

The flow through the reference compartment should be adapted to the sample gas flow.

## Design

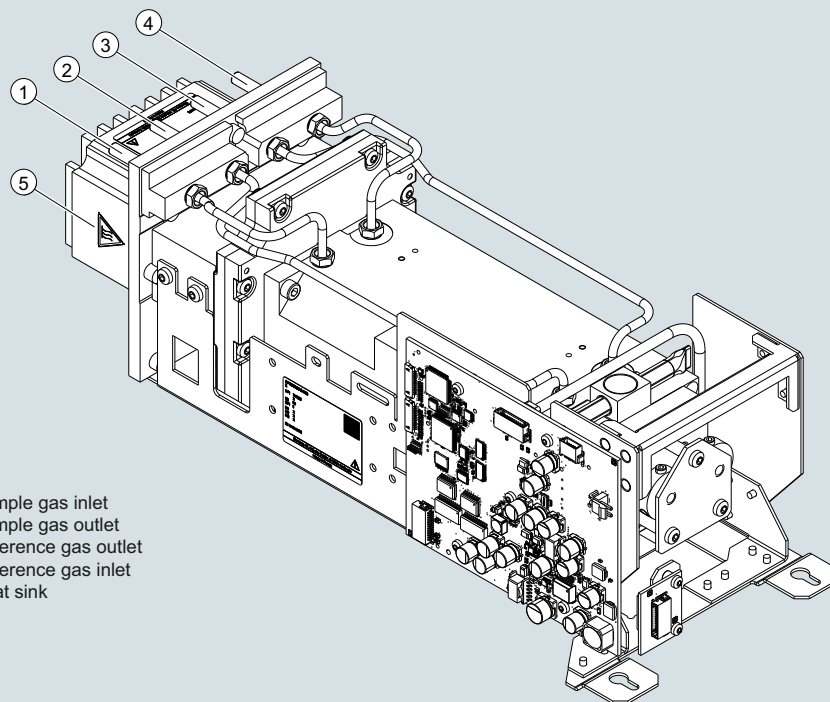

- 1 Sample gas inlet
- 2 Sample gas outlet
- 3 Reference gas outlet
- 4 Reference gas inlet
- 5 Heat sink

Structure of ULTRAMAT 7

## Extractive continuous process gas analysis

### SIPROCESS GA700

#### ULTRAMAT 7 module

#### Gas path

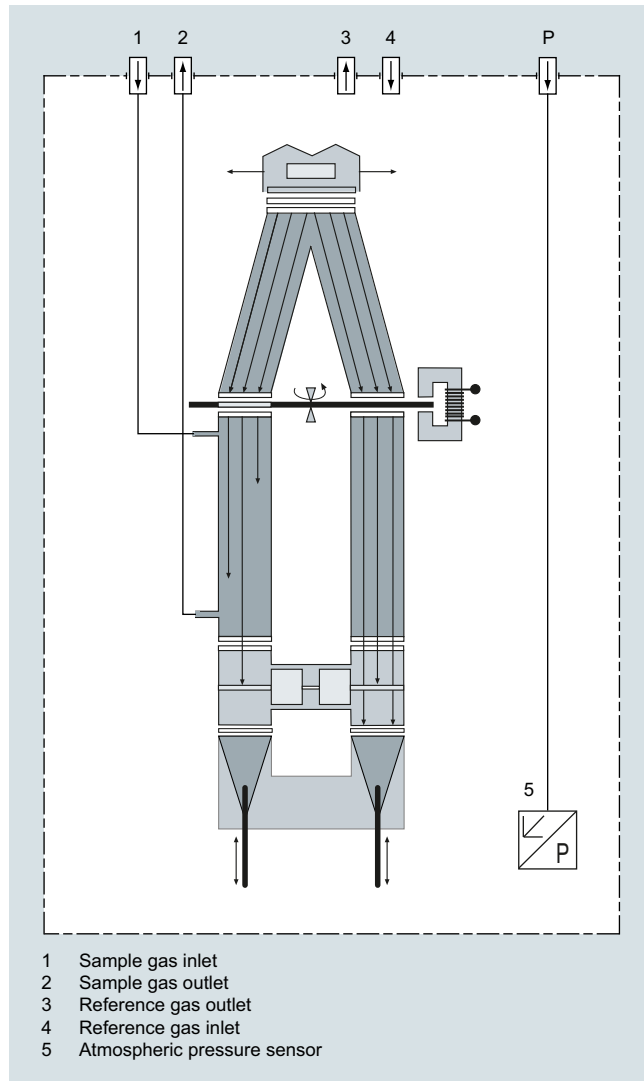

ULTRAMAT 7, gas path, without flow-type reference side

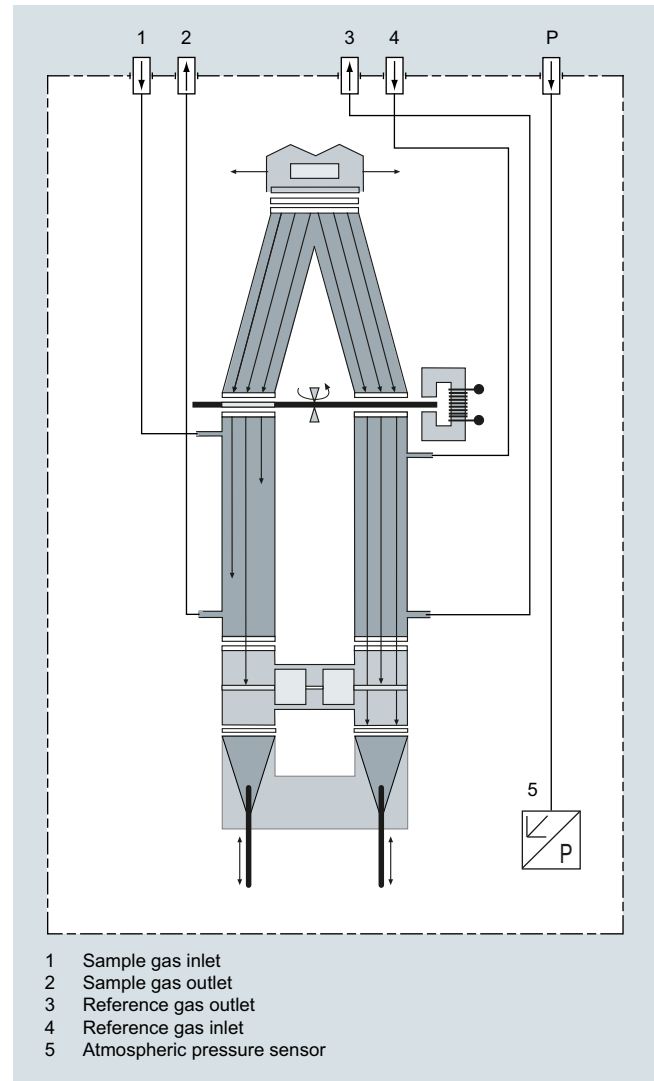

ULTRAMAT 7, gas path, with flow-type reference side

## Mode of operation

### Measuring principle

The measurements are based on the molecular-specific absorption of infrared radiation bands (absorption bands).

ULTRAMAT 7 modules use a spectral range which includes wavelengths of 2 to 9  $\mu\text{m}$ . Although the absorbing wavelengths are characteristic of individual gases, they may partially overlap. This results in cross-sensitivities which are reduced to a minimum by the following measures:

- Beam splitter (gas filter)
- Double-layer detector, each gas compartment with adjustable weighting between the first and second detector layer
- Application-specific pre-installed interference filter

### Principle of operation

ULTRAMAT 7 modules operate according to the infrared push-pull chopped radiation principle and are equipped with a double-layer detector.

A source with a temperature of approx. 600 °C generates infrared radiation which is emitted in the beam splitter. The beam splitter acts as a filter chamber and divides the beam equally between the sample gas and reference gas compartments.

The chopper produces a periodic modulation of the infrared radiation, and thus enables relaxation of the detector.

The reference beam passes through the reference chamber and enters the detector chamber virtually unattenuated. The detector chamber is filled with a precisely defined concentration of the gas component to be measured. The sample beam, in contrast, passes through the sample chamber filled with sample gas and enters the detector chamber attenuated to various degrees. The degree of attenuation depends on the respective sample gas concentration.

The detector is designed as a double-layer detector. The detector layer at the source end serves primarily to absorb the middle of the band. The band edges, however, are absorbed equally by both of the layers.

The detector layers at both compartments of the detector are pneumatically connected to each other via a microflow sensor. This sensor element converts the pressure difference in the detector into an electrical signal.

The weighting between the first and second detector layer is preset at the factory depending on the application. To ensure the long-term stability of the measured value, the ULTRAMAT 7 module supports the predictive self-diagnostics of the analyzer. This function enables you to plan maintenance measures in a timely manner.

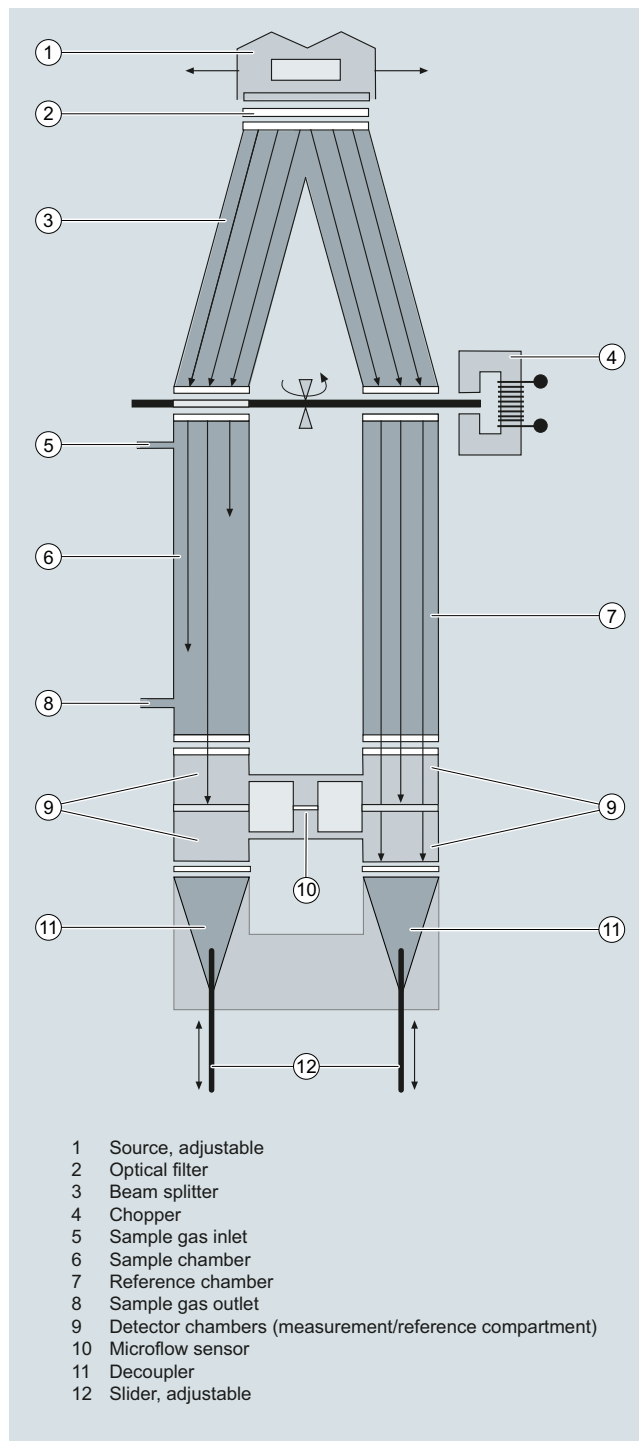

ULTRAMAT 7, principle of operation of the infrared channel

# Extractive continuous process gas analysis

## SIPROCESS GA700

### ULTRAMAT 7 module

1

#### Essential characteristics

- Dimension of measured value freely selectable (e.g. vpm, mg/m<sup>3</sup>)
- Four freely-configurable measuring ranges per component
- Measuring ranges with suppressed zero point possible
- Measuring range identification
- Autoranging or manual measurement range switchover possible; remote switching is also possible
- Differential measuring ranges with flow-type reference cell
- Storage of measured values possible during adjustments
- Time constants selectable within wide limits (static/dynamic noise suppression); i.e. the response time of the analyzer or component can be matched to the respective measuring task
- Short response time
- Low long-term drift
- Measuring point switchover for up to 4 measuring points (programmable)
- Measuring point identification
- Internal pressure sensor for correction of atmospheric pressure fluctuations in the range 700 to 1 200 hPa absolute
- Automatic measuring range calibration can be configured
- Operation based on NAMUR recommendation
- Preventive maintenance / IR source monitoring
- Sample chamber for use in presence of highly corrosive sample gases, e.g. tantalum inlay sheet or Hastelloy C22 (special application)

#### Technical specifications

The technical specifications are based on the definitions of DIN EN 61207-1.

Unless specified otherwise, the data listed below relates to the following measurement conditions:

Ambient temperature	25 °C
Atmospheric pressure	Atmospheric (approx. 1 000 hPa)
Sample gas flow	0.6 l/min (or NI/min)
Sample gas humidity	Dew point < -40 °C
Site of installation	Vibration- and impact-free

#### General information

Weight	Max. 5.2 kg (standard version)
--------	--------------------------------

#### Measuring ranges

Number of measuring ranges	Max. 4; parameters can be assigned freely
Parameters can be assigned in the measuring ranges	
• Smallest possible measuring span	CO: 0 ... 10 vpm CO <sub>2</sub> : 0 ... 5 vpm CH <sub>4</sub> : 0 ... 50 vpm C <sub>2</sub> H <sub>4</sub> : 0 ... 300 vpm SO <sub>2</sub> : 0 ... 50 vpm NO: 0 ... 100 vpm N <sub>2</sub> O: 0 ... 50 vpm NH <sub>3</sub> : 0 ... 100 vpm CO/NO: 0 ... 100 vpm CO <sub>2</sub> /CO: 0 ... 100 vpm
• Largest possible measuring span	CO: 0 ... 100% CO <sub>2</sub> : 0 ... 100% CH <sub>4</sub> : 0 ... 100% C <sub>2</sub> H <sub>4</sub> : 0 ... 100% SO <sub>2</sub> : 0 ... 100% NO: 0 ... 30 000 vpm N <sub>2</sub> O: 0 ... 100% NH <sub>3</sub> : 0 ... 100% CO/NO: 0 ... 10 000 vpm CO <sub>2</sub> /CO: 0 ... 100%

#### Gas inlet conditions

Sample gas pressure	
• Standard pressure (atmospheric pressure compensation)	500 to 1 500 hPa (absolute)
Pressure drop between sample gas inlet and sample gas outlet	< 10 hPa at 1.5 l/min
Sample gas flow	18 ... 90 l/h (0.3 ... 1.5 l/min)
Sample gas temperature	0 to 50 °C
Sample gas humidity (rel. humidity)	< 90% (condensation inside the gas path is to be avoided)

#### Dynamic response

Warm-up period at room temperature	< 2 h
Response characteristics	
• Dead time (T <sub>10</sub> )	Application-specific (max. 3.6 s)
• Signal rise time (T <sub>r</sub> ) or fall time (T <sub>f</sub> ) with application-specific electronic damping of 10 s	Application specific < 14 s
• Time for device-internal signal processing T <sub>v</sub>	Approx. 1 s
• Delayed display T <sub>90</sub>	Rule: T <sub>90</sub> < T <sub>10</sub> + T <sub>r/f</sub> + T <sub>v</sub>

<b>Measuring response</b>	
Output signal fluctuation	$\leq \pm 1\%$ of smallest measuring range acc. to nameplate
Zero point drift	$< \pm 1\%$ /week of smallest measuring range acc. to nameplate
Measured-value drift	$\leq 1\%$ of the current measuring range per week
Repeatability	$\leq \pm 1\%$ of the current full-scale value
Linearity error	$< \pm 0.5\%$ of the current full-scale value
<b>Influencing variables</b>	
Ambient temperature • Measured value	$\leq 1\%$ of the current measuring range/ 10 K (at constant receiver cell temperature)
Sample gas pressure • Without pressure compensation	$\leq 1.5\%$ of the current measuring range/1% pressure variation
• With pressure compensation switched on	$\leq 0.15\%$ of the current measuring range/1% pressure variation
Sample gas flow	$\leq 1\%$ of the current full-scale value/ 0.1 l/min change in flow
Supply voltage	$\leq 0.1\%$ of the current measuring range (with the nominal range of use)
<b>Electrical outputs</b>	
Analog and digital interfaces	See base unit
<b>Climatic conditions</b>	
Storage and transport	-30 ... 70 °C
Permissible ambient temperature (during operation in base unit) <sup>1)</sup>	5 ... 45 °C
Relative humidity (RH) during storage, transport or operation	$< 90\%$ (condensation from the installed components is to be avoided)
<b>Gas connections</b>	
Connection fittings	Pipe connection with 6 mm outer diameter
<b>Materials of wetted parts</b>	
Bushing	Stainless steel mat. no. 1.4571, Hastelloy C22
Pipe	Stainless steel mat. no. 1.4571, Hastelloy C22, O-ring: FKM (e.g. Viton) or FFKM (Kalrez 6375)
Sample chamber • Body	Aluminum
• Lining	Aluminum, tantalum
• Window	CaF <sub>2</sub> , adhesive: E353, O-ring: FKM (e.g. Viton) or FFKM (Kalrez 6375)

<sup>1)</sup> Applies also in combination with OXYMAT 7 or CALOMAT 7 modules

# Extractive continuous process gas analysis

## SIPROCESS GA700

### ULTRAMAT 7 module

1

#### Selection and ordering data

#### ULTRAMAT 7 module

For measuring IR-absorbing gases

Click on the Article No. for the online configuration in the PIA Life Cycle Portal.

#### Module version

Standard module for 19" rack unit and wall housing

#### Measured components<sup>1)</sup>

Possible with measuring range identification

CO	B <sup>2)</sup> , C ... P
CO <sub>2</sub>	A <sup>2)</sup> , B ... P
CH <sub>4</sub>	D <sup>2)</sup> , E ... P
C <sub>2</sub> H <sub>4</sub>	F <sup>2)</sup> , G... P
SO <sub>2</sub>	D <sup>2)</sup> , E... P
NO	E <sup>2)</sup> , F... P
N <sub>2</sub> O	D <sup>2)</sup> , E ... P
NH <sub>3</sub> (dry)	E <sup>2)</sup> , F... P
CO, NO	E <sup>2)</sup> , F, H, R, S
CO <sub>2</sub> , CO	E, F, H, J, L, M, P

#### Smallest measuring range

#### Largest measuring range

0 ... 5 vpm	0 ... 100 vpm
0 ... 10 vpm	0 ... 200 vpm
0 ... 20 vpm	0 ... 400 vpm
0 ... 50 vpm	0 ... 1 000 vpm
0 ... 100 vpm	0 ... 1 000 vpm
0 ... 300 vpm	0 ... 3 000 vpm
0 ... 500 vpm	0 ... 5 000 vpm
0 ... 1 000 vpm	0 ... 10 000 vpm
0 ... 3 000 vpm	0 ... 30 000 vpm
0 ... 5 000 vpm	0 ... 50 000 vpm
0 ... 1 %	0 ... 10 %
0 ... 3 %	0 ... 30 %
0 ... 5 %	0 ... 50 %
0 ... 10 %	0 ... 100 %
0 ... 100 vpm (CO), 0 ... 300 vpm (NO)	0 ... 1 000 vpm CO, NO
0 ... 300 vpm (CO), 0 ... 500 vpm (NO)	0 ... 3 000 vpm CO, NO

#### Gas path

#### Material of gas path

Pipe made of stainless steel
Pipe made of stainless steel
Pipe made of Hastelloy

#### Material of sample chamber

with aluminum lining
with tantalum lining <sup>3)</sup>
with tantalum lining <sup>3)</sup>

#### Reference chamber

Non-flow-type

Flow-type

#### Pressure compensation

Atmospheric pressure compensation

#### Module variant

For rack-mounted enclosure

For wall enclosure

#### Version

Standard

#### Article No.

7MB3010- - A Cannot be combined

0

A  
C  
D  
E  
F  
G  
H  
J  
Q  
R

A  
D  
E  
F  
G  
H  
J

A A A A A A A  
B B B B B B  
C C C C C C  
D D D  
E  
K  
L  
M  
N  
P  
R  
S

1  
2  
3

0

1

0

A

B

0

<sup>1)</sup> C<sub>2</sub>H<sub>2</sub>, C<sub>2</sub>H<sub>6</sub>, C<sub>3</sub>H<sub>6</sub>, C<sub>3</sub>H<sub>8</sub>, C<sub>4</sub>H<sub>6</sub>, C<sub>4</sub>H<sub>10</sub>, C<sub>6</sub>H<sub>14</sub>, H<sub>2</sub>O, possible as special application 7MB3017..

<sup>2)</sup> Not possible in combination with an OXYMAT 7 module.

<sup>3)</sup> Only for cell length 20 ... 180 mm.

### Selection and ordering data

#### Additional versions

Add "-Z" to Article No. and specify Order code

#### Order Code

#### Settings

Kalrez (6375) seals in sample gas path

**B04**

Clean for O<sub>2</sub> service (specially cleaned gas path)

**B06**

Measuring range indication in plain text, if different from the default setting

**Y11**

Special setting (only together with an application no., e.g. extended measuring range)

**Y12**

Extended special setting (only together with an application no., e.g. determination of cross-interferences)

**Y13**

Base unit module assignment number

**D00 ... D99**

### Ordering example

ULTRAMAT 7 module installed in rack unit enclosure

**7MB3000-0BX00-1AA0-Z+D03**

**7MB3010-0AB10-0AA0-Z+D03**

ULTRAMAT 7 module and rack unit enclosure supplied separately

**7MB3000-0BX00-1AA0**

**7MB3010-0AB10-0AA0**

**Extractive continuous process gas analysis**

SIPROCESS GA700

**ULTRAMAT 7 module**

1

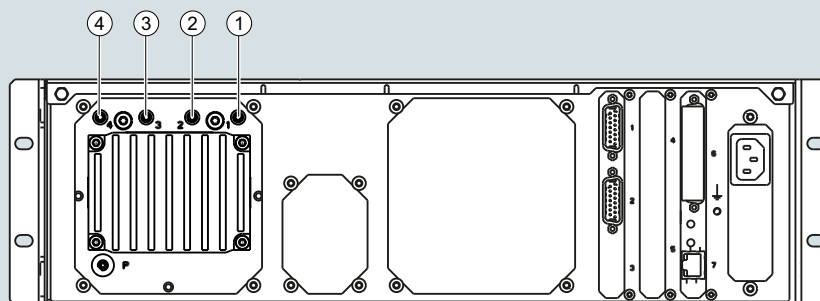
**Circuit diagrams****Gas connections**

- 1 Sample gas inlet
- 2 Sample gas outlet
- 3 Reference gas outlet
- 4 Reference gas inlet
- P Atmospheric pressure sensor

The sample gas connections and the reference gas connections are made of stainless steel, mat. no. 1.4404. The gas connections are designed as connection fittings with a pipe diameter of 6 mm.

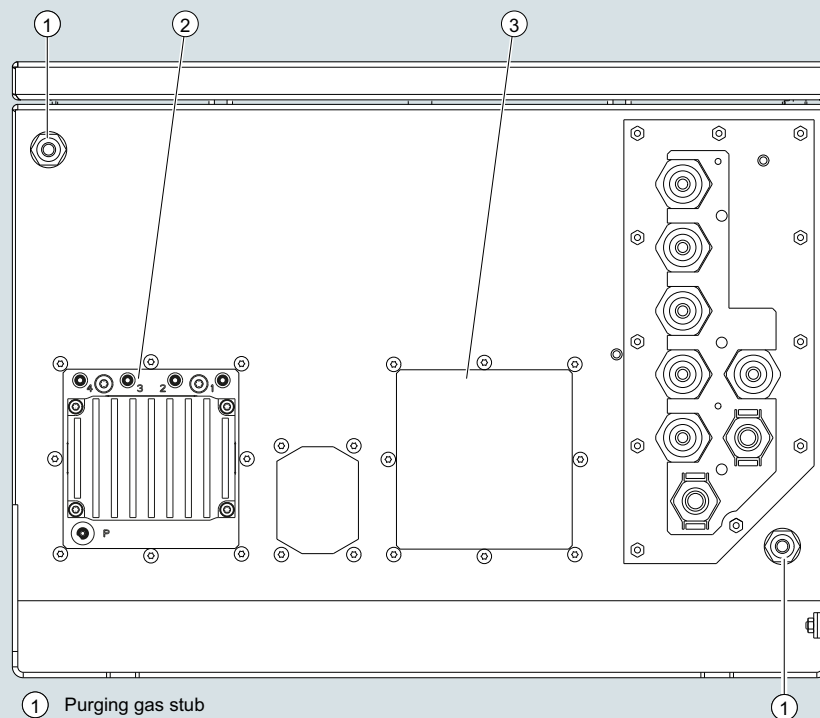
**Wall-mounted device**

- ① Purging gas stub
- ② Slot of module 1: ULTRAMAT 7
- ③ Slot of module 2

Wall-mounted device, bottom