

SIEMENS

SITRANS F

Ultrasonic Flowmeters SITRANS FUS060 with HART

Operating Instructions

7ME305 (FUS060 with HART)

09/2021

A5E01204521-AL

<u>Introduction</u>	1
<u>Safety notes</u>	2
<u>Description</u>	3
<u>Installing/Mounting</u>	4
<u>Connecting</u>	5
<u>Commissioning</u>	6
<u>Functions</u>	7
<u>Service and maintenance</u>	8
<u>Diagnostics and troubleshooting</u>	9
<u>Technical specifications</u>	10
<u>Dimension drawings</u>	11
<u>Product documentation and support</u>	A
<u>HART communication</u>	B
<u>HMI menu structure</u>	C

Legal information

Warning notice system

This manual contains notices you have to observe in order to ensure your personal safety, as well as to prevent damage to property. The notices referring to your personal safety are highlighted in the manual by a safety alert symbol, notices referring only to property damage have no safety alert symbol. These notices shown below are graded according to the degree of danger.

 DANGER
indicates that death or severe personal injury will result if proper precautions are not taken.

 WARNING
indicates that death or severe personal injury may result if proper precautions are not taken.

 CAUTION
indicates that minor personal injury can result if proper precautions are not taken.

NOTICE
indicates that property damage can result if proper precautions are not taken.

If more than one degree of danger is present, the warning notice representing the highest degree of danger will be used. A notice warning of injury to persons with a safety alert symbol may also include a warning relating to property damage.

Qualified Personnel

The product/system described in this documentation may be operated only by **personnel qualified** for the specific task in accordance with the relevant documentation, in particular its warning notices and safety instructions. Qualified personnel are those who, based on their training and experience, are capable of identifying risks and avoiding potential hazards when working with these products/systems.

Proper use of Siemens products

Note the following:

 WARNING
Siemens products may only be used for the applications described in the catalog and in the relevant technical documentation. If products and components from other manufacturers are used, these must be recommended or approved by Siemens. Proper transport, storage, installation, assembly, commissioning, operation and maintenance are required to ensure that the products operate safely and without any problems. The permissible ambient conditions must be complied with. The information in the relevant documentation must be observed.

Trademarks

All names identified by ® are registered trademarks of Siemens AG. The remaining trademarks in this publication may be trademarks whose use by third parties for their own purposes could violate the rights of the owner.

Disclaimer of Liability

We have reviewed the contents of this publication to ensure consistency with the hardware and software described. Since variance cannot be precluded entirely, we cannot guarantee full consistency. However, the information in this publication is reviewed regularly and any necessary corrections are included in subsequent editions.

Table of contents

1	Introduction	7
1.1	Purpose of this documentation	7
1.2	Scope of documentation	7
1.3	Document history	7
1.4	Designated use	8
1.5	Checking the consignment.....	8
1.6	Items supplied	8
1.7	Security information	9
1.8	Transportation and storage	9
1.9	How to read the Operating Instructions.....	10
1.10	Further Information	10
2	Safety notes	13
2.1	General safety instructions.....	13
2.2	Laws and directives	13
2.3	Installation in hazardous locations.....	14
3	Description	19
3.1	Overview	19
3.2	Design	19
3.3	Nameplate layout.....	21
3.4	Measuring principle	22
4	Installing/Mounting	25
4.1	Introduction.....	25
4.2	Transmitter installation	26
4.2.1	Standard wall-mounting bracket.....	26
4.2.2	Pipe or wall mounting with assembly bracket	26
4.2.3	Turning the local display.....	28
5	Connecting	29
5.1	Wiring the transducer cables	31
5.2	Wiring output and power supply	33
6	Commissioning	37
6.1	Start up	37
6.2	Operating the device.....	37

6.3	Commissioning via local user interface	38
6.3.1	Operating via local display	38
6.3.2	Operating via HART communication	38
6.3.3	Navigating the menu	39
6.3.4	Write protection	40
6.3.5	Operating examples	41
6.4	Commissioning via SIMATIC PDM.....	43
6.4.1	Configuration.....	44
7	Functions	47
7.1	Display (menu 1)	47
7.2	Diagnostics (menu 2).....	49
7.3	Measuring functions (menu 3)	50
7.4	Device outputs (menu 4).....	53
7.5	Identification (menu 5)	58
7.6	Service (menu 6)	59
7.7	Sensor parameters (menu 7).....	61
8	Service and maintenance	67
8.1	Maintenance.....	67
8.2	Return procedure	67
8.3	Keying in sensor data	68
9	Diagnostics and troubleshooting.....	71
9.1	Application information guide.....	73
10	Technical specifications	75
10.1	SITRANS FUS060	75
11	Dimension drawings.....	81
11.1	Dimensional drawings.....	81
A	Product documentation and support	83
A.1	Product documentation	83
A.2	Technical support.....	84
B	HART communication	85
B.1	Universal commands.....	85
B.2	Common practice commands.....	86
B.3	Device-specific commands	88
C	HMI menu structure.....	103
C.1	Menu items (FW Rev. 4.00.00-15)	104
C.1.1	Menu 1 - Display	104
C.1.2	Menu 2 - Diagnostics	106
C.1.3	Menu 3 - Measuring functions.....	107

C.1.4	Menu 4 - Device outputs	110
C.1.5	Menu 5 - Identification	111
C.1.6	Menu 6 - Service	112
C.1.7	Menu 7 - Sensor parameters.....	115
Index	121

Introduction

1.1 Purpose of this documentation

These instructions contain all information required to commission and use the device. Read the instructions carefully prior to installation and commissioning. In order to use the device correctly, first review its principle of operation.

The instructions are aimed at persons mechanically installing the device, connecting it electronically, configuring the parameters and commissioning it, as well as service and maintenance engineers.

1.2 Scope of documentation

For flowmeters based on the FUS060 transmitter various technical literature such as operating instructions and quick start guides are available on the CD-ROM shipped with the device, or it can be found on the Internet at www.siemens.com/flowdocumentation (www.siemens.com/flowdocumentation), where further information on the SITRANS F flowmeter range is also available.

SITRANS F US sensor and transmitter versions have separate operating instructions.

These Operating Instructions concern only the FUS060 HART transmitter part of the flowmeter system. The FUS060 PROFIBUS PA transmitter version and SONO 3100, SONO 3300 or SONOKIT sensors have separate operating instructions.

1.3 Document history

The contents of these instructions are regularly reviewed and corrections are included in subsequent editions. We welcome all suggestions for improvement.

The following table shows the most important changes in the documentation compared to each previous edition.

Edition	Remarks	FW version	EDD version
09/2021	<ul style="list-style-type: none"> New firmware Minor firmware correction for high flow rates up 12 m/s Cable glands information 	4.00.00-15	4.00.00
08/2015	<ul style="list-style-type: none"> New firmware Frontend update 	4.00.00	4.00.00

1.6 Items supplied

Edition	Remarks	FW version	EDD version
03/2014	<ul style="list-style-type: none"> • Diagnostics section improved • HART description added • Description of new functions added • General update according to FW update 	3.00.00	2.00.00
11/2009	<ul style="list-style-type: none"> • First edition 	2.01.07	1.00.01

1.4 Designated use

Use the device in accordance with the information on the nameplate and in the Technical specifications (Page 75).

1.5 Checking the consignment

1. Check the packaging and the delivered items for visible damages.
2. Report any claims for damages immediately to the shipping company.
3. Retain damaged parts for clarification.
4. Check the scope of delivery by comparing your order to the shipping documents for correctness and completeness.

**WARNING****Using a damaged or incomplete device**

Risk of explosion in hazardous areas.

- Do not use damaged or incomplete devices.

1.6 Items supplied

- SITRANS FUS060
- Wall mounting bracket (standard)
- DVD containing certificates
- Safety note

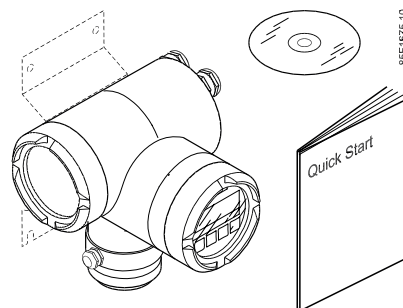

Note

Scope of delivery may vary, depending on version and add-ons. Make sure the scope of delivery and the information on the nameplate correspond to your order and the delivery note.

1.7 Security information

Siemens provides products and solutions with industrial security functions that support the secure operation of plants, systems, machines and networks.

In order to protect plants, systems, machines and networks against cyber threats, it is necessary to implement – and continuously maintain – a holistic, state-of-the-art industrial security concept. Siemens' products and solutions constitute one element of such a concept.

Customers are responsible for preventing unauthorized access to their plants, systems, machines and networks. Such systems, machines and components should only be connected to an enterprise network or the internet if and to the extent such a connection is necessary and only when appropriate security measures (e.g. firewalls and/or network segmentation) are in place.

For additional information on industrial security measures that may be implemented, please visit

<https://www.siemens.com/industrialsecurity>.

Siemens' products and solutions undergo continuous development to make them more secure. Siemens strongly recommends that product updates are applied as soon as they are available and that the latest product versions are used. Use of product versions that are no longer supported, and failure to apply the latest updates may increase customer's exposure to cyber threats.

To stay informed about product updates, subscribe to the Siemens Industrial Security RSS Feed under

<https://www.siemens.com/industrialsecurity>.

1.8 Transportation and storage

To guarantee sufficient protection during transport and storage, observe the following:

- Keep the original packaging for subsequent transportation.
- Devices/replacement parts should be returned in their original packaging.
- If the original packaging is no longer available, ensure that all shipments are properly packaged to provide sufficient protection during transport. Siemens cannot assume liability for any costs associated with transportation damages.

NOTICE
Insufficient protection during storage
The packaging only provides limited protection against moisture and infiltration.
<ul style="list-style-type: none"> • Provide additional packaging as necessary.

Special conditions for storage and transportation of the device are listed in Technical specifications (Page 75).

The contents of this manual shall not become part of or modify any prior or existing agreement, commitment or legal relationship. The sales contract contains all obligations on the part of Siemens as well as the complete and solely applicable warranty conditions. Any statements regarding device versions described in the manual do not create new warranties or modify the existing warranty.

The content reflects the technical status at the time of publishing. Siemens reserves the right to make technical changes in the course of further development.

1.9 How to read the Operating Instructions

These Operating Instructions describe only the installation of the FUS060 HART transmitter (with HART interface). The flowmeter consists of a transmitter (FUS060) and a sensor (SONO 3100, SONO 3300 or SONOKIT) and is designed for measuring the flow velocity of liquids in full pipes. Satisfactory function of the ultrasonic flowmeter depends on a low sound attenuation of the medium and a well-defined and stable flow profile.

The installation of ultrasonic flowmeter system divided into 5 steps:

1. Selection of the measuring site
2. Installation of the sensor in the pipe (see separate sensor manual)
3. Mechanical installation of the transmitter (for example wall mounting)
4. Electrical connection of the transmitter
5. Electrical connection of the sensor transducers to the transmitter

Siemens Flow Instruments SITRANS F US ultrasonic flowmeters are designed for measurement of:

- Volume or mass flowrate
- Limit monitoring
- Total volume or mass
- Sound velocity in the media

SITRANS F US ultrasonic flowmeters measure flow in standard volumetric and mass flow units. Measurement is independent of changes in liquid temperature, density, pressure, and conductivity. This ultrasonic flowmeter is designed for use on single phase liquids.

1.10 Further Information

Product information on the Internet

The Operating Instructions are available on the documentation disk shipped with the device, and on the Internet on the Siemens homepage, where further information on the range of SITRANS F flowmeters may also be found:

Product information on the internet (<http://www.siemens.com/flowdocumentation>)

Worldwide contact person

If you need more information or have particular problems not covered sufficiently by these Operating Instructions, get in touch with your contact person. You can find contact information for your local contact person on the Internet:

Local contact person (http://www.automation.siemens.com/aspa_app/contactmenu.aspx?ci=yes®id=DEF&lang=en)

Safety notes

2.1 General safety instructions



CAUTION

Correct, reliable operation of the product requires proper transport, storage, positioning and assembly as well as careful operation and maintenance.

Only qualified personnel should install or operate this instrument.

Note

Alterations to the product, including opening or improper modifications of the product are not permitted.

If this requirement is not observed, the CE mark and the manufacturer's warranty will expire.

2.2 Laws and directives

General requirements

Installation of the equipment must comply with national regulations. For example EN 60079-14 for the European Community.

Instrument safety standards

The device has been tested at the factory, based on the safety requirements. In order to maintain this condition over the expected life of the device the requirements described in these Operating Instructions must be observed.

NOTICE

Material compatibility

Siemens Flow Instruments can provide assistance with the selection of wetted sensor parts. However, the full responsibility for the selection rests with the customer and Siemens Flow Instruments can take no responsibility for any failure due to material incompatibility.

Conformity with European directives

The CE marking on the device symbolizes the conformity with the following European directives:

Electromagnetic compatibility EMC 2014/30/EU	Directive of the European Parliament and of the Council on the harmonisation of the laws of the Member States relating to electromagnetic compatibility
Low voltage directive LVD 2014/35/EU	Directive of the European Parliament and of the Council on the harmonisation of the laws of the Member States relating to the making available on the market of electrical equipment designed for use within certain voltage limits
Atmosphère explosible ATEX 2014/34/EU	Directive of the European Parliament and the Council on the harmonisation of the laws of the Member States relating to equipment and protective systems intended for use in potentially explosive atmospheres
Pressure equipment directive PED 2014/68/EU	Directive of the European Parliament and of the Council on the harmonisation of the laws of the Member States relating to the making available on the market of pressure equipment
2011/65/EU RoHS	Directive of the European Parliament and the Council on the restriction of the use of certain hazardous substances in electrical and electronic equipment

The applicable directives can be found in the EU declaration of conformity of the specific device. Further country or region-specific code conformity information is available on request.

2.3 Installation in hazardous locations

 WARNING
Equipment used in hazardous locations
Equipment used in hazardous locations must be Ex-approved for the region of installation and marked accordingly. It is required that the special conditions for safe use provided in the manual and in the Ex certificate are followed!

Hazardous area approvals

The device is approved for use in hazardous area and has the following approval:

- PTB 07 ATEX 2033 X with the marking: II 2 G Ex db eb mb [ia Ga] IIC T6...T3 Gb

The device's compliance with Essential Health and Safety Requirements has been assured by compliance with:

EN IEC 60079-0:2018; EN 60079-1:2014, EN IEC 60079-7:2015+A1:2018, EN 60079-11:2012, EN 60079-18:2015/A1:2017

 WARNING
Field wiring installation
Make sure the hazardous area approval is suitable for the environment in which the device will be installed.

Intrinsically safe data

Power supply

19.2 V to 30 V DC, approximately 10 W or 20.4 to 26.4 V AC, approximately 10 VA

Fuse: 4 A / breaking capacity 1500 A

Table 2-1 Intrinsically safe data

HART output (Terminals 7+ and 8-)	Linear barrier ia/ib IIC/IIB (active output)
U_o	15.8 V
I_o	64 mA
P_o	253 mW
R_i	250 Ω

	IIC				IIB				
L_o	0	0.5	2.0	9.6	0	1	5	44	[mH]
C_o	470	420	360	160	2800	2600	1600	650	[nF]

Figure 2-1 Admissible outer reactances

Digital output 1 (pulse/frequency/limit) (Terminals 5+ and 6-)	Ex ia IIC/IIB or Ex ib IIC/IIB (passive output)
U_i	30 V
I_i	100 mA
C_i	24 nF
L_i	108 μ H
P_i	750 mW

Digital output 2 (relay) (Terminals 3+ and 4-)	Ex ia IIC/IIB or Ex ib IIC/IIB (passive output)
U_i	30 V
I_i	100 mA (DC), 50 mA (AC)
C_i	24 nF
L_i	73 μ H

<p>⚠ WARNING</p> <p>Use with intrinsically safe circuits</p> <p>With intrinsically safe circuits, use only certified sensors appropriate for the transmitter.</p> <p>If a non-conforming supply unit is used, the "Intrinsic Safety" type of protection will no longer be effective and the approval certification will be invalid.</p>

Permissible medium temperature specifications for Ex use

Temperature class	Ambient temperature [°C]	
	-20 to +40	-20 to +50
T3	165	140
T4	100	100
T6	50	50

Hazardous area safety requirements

Special conditions for safe use

1. The sensor circuits of the transmitter, type SITRANS FUS060 are exclusively intended for connection to the associated sensor units of types SITRANS FUS SONO 3100, SITRANS FUS SONO 3000 and SITRANS FUS SONOKIT, which – for their part – are approved only for connection to a transmitter of type series SITRANS FUS060.
2. The connecting cable of the transmitter, type SITRANS FUS060 shall be layed as fixed installation and in such a way that it is sufficiently protected against damage.
3. The transmitter, type SITRANS FUS060 shall be included in the local equipotential bonding system.
4. Non-used openings shall be sealed according to EN 60079-0.

Notes for manufacture and operation

For the assembly, mounting and installation only such components (e.g. terminal compartments, cable glands, Ex cable entries, connection facilities) are approved which technically comply with the status of the standards given on the cover sheet as a minimum and for which a separate certificate is available. The operating conditions stated in the respective certificates of these components shall be absolutely observed.

Connection requirements

It is required that:

- Electrical connections are in accordance with Elex V (VO in explosion hazardous areas) and EN60079-14 (Installing Electrical Systems in Explosion Hazardous Areas).
- The protective cover over the power supply is properly installed. For intrinsically safe circuits the connection area can be opened.

- Appropriate cable connectors are used for the output circuits:
 - Intrinsically safe: blue
 - Non-intrinsically safe: black
- Sensor and transmitter are connected to the equipotential bonding system (PA) (min. 4 mm²).
For intrinsically safe output circuits potential equalization must be maintained along the entire connection path.
- When protective earth (PE) is connected, no potential difference between the protective earth (PE) and the equipotential bonding system (PA) can exist, even during a fault condition.

 **WARNING**

"Flameproof enclosure" type of protection

Only open devices with type of protection "Flameproof enclosure" in hazardous areas when the power to the device is turned off, otherwise there is a risk of explosion.

 **WARNING**

500 V insulation test

The device is not capable of withstanding the 500 V insulation test required by Clause 6.3.12 of EN60079-11. This must be taken into account when installing the device.

 **WARNING**

Laying of cables

Cable for use in zone 1 and 2 or 21 and 22 must satisfy the requirements for having a proof voltage < 500 V AC applied between the conductor/ground, conductor/shield and shield/ground.

Connect the devices that are operated in hazardous areas as per the stipulations applicable in the country of operation, e.g. for Ex "d" and "nA", permanent cables must be laid.

2.3 Installation in hazardous locations

Description

3.1 Overview

The SITRANS F US ultrasonic flowmeter systems consist of a sensor and a transmitter. This system consists of sensor type SONO 3100, SONO 3300 or SONOKIT and the transmitter type FUS060. The following table shows the ultrasonic flowmeter systems with the transmitter type FUS060:

Sensor type	Transmitter	Outputs	Measurement
SONO 3100 DN 100 – DN 1200 SONO 3300 DN 50 – DN 300 SONOKIT DN 100 – DN 4000	FUS060	<ul style="list-style-type: none"> • 1 analog with HART • 1 frequency/pulse • 1 relay 	<ul style="list-style-type: none"> • Volume flow rate • Total volume • Mass flow rate • Total mass • Sound velocity • Error indication • Limit monitoring • Ultrasonic amplitude

These Operating Instructions is only for the transmitter part of the flowmeter system. The SONO 3100, SONO 3300 or SONOKIT sensors have separate operating instructions.

The FUS060 is configured in a combination of hardware (HW) and firmware (FW). For communication via SIMATIC PDM firmware-specific device descriptions are needed. The various relations are listed below:

Device		EDD (device description)		
HW	FW	1.00.01	2.00.00	4.00.00
02.00	2.01.04	X		
02.00	2.01.07	X		
02.00	3.00.00		X	
04.00	4.00.00-15			X

3.2 Design

SITRANS FUS060 is an ultrasonic flow transmitter engineered for high performance and suitable for use with 1-path, 2-path, and 4-path flow sensors.

The complete flowmeter consists of an ultrasonic flow sensor of the types SONO 3100, SONO 3300 or SONOKIT and the associated SITRANS FUS060 transmitter.

The ultrasonic flow sensors are available with diameters up to DN 4000.



Figure 3-1 FUS060

3.3 Nameplate layout

FUS060 transmitter identification nameplate

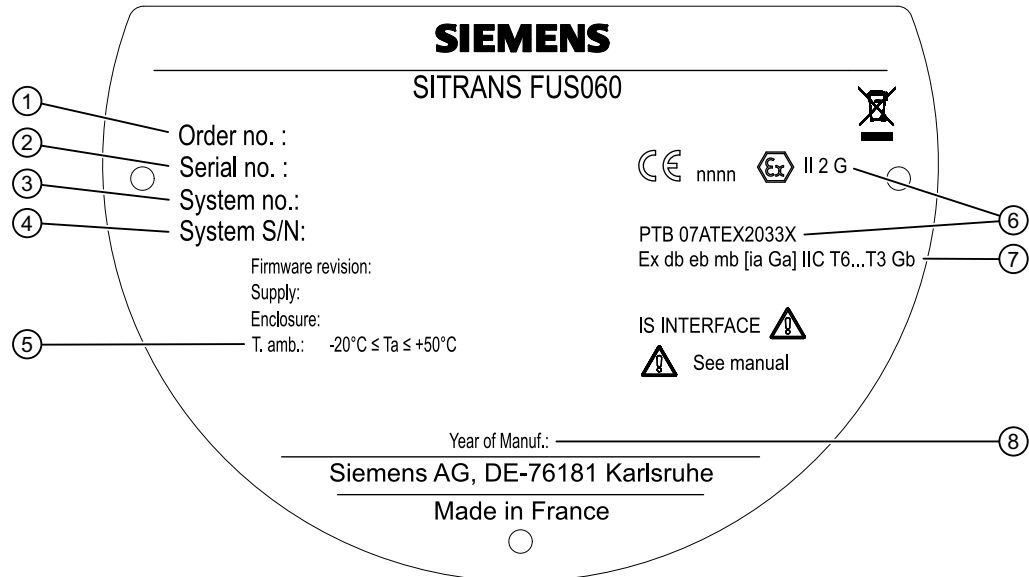

①	Code no.	Transmitter order number
②	Serial no.	Transmitter serial number
③	System no.	System order number
④	System S/N	System serial number
⑤	Temp Amb.	Ambient temperature range
⑥	PTB 07ATEX2033X	Certification number
⑦	II 2 G Ex db eb mb [ia Ga] IIC T6...T3 Gb	Marking
	II	Group II
	2	Category 2 for use in Zone 1
	G	For gas
	Ex	Ex protection for use in explosive Atmosphere
	db	Type of protection flame proof enclosure
	eb	Type of protection increased safety
	mb	Type of protection encapsulation
	[ia GA]	Interface for circuits with type of protection intrinsic safety
	IIC	Gas group IIC
	T6...T3	Temperature class (read manual)
	Gb	Protection level Gb for use in Zone 1
⑧	Year of Manuf.	Year of manufacture

Figure 3-2 FUS060 identification nameplate example

3.4 Measuring principle

Physical principle

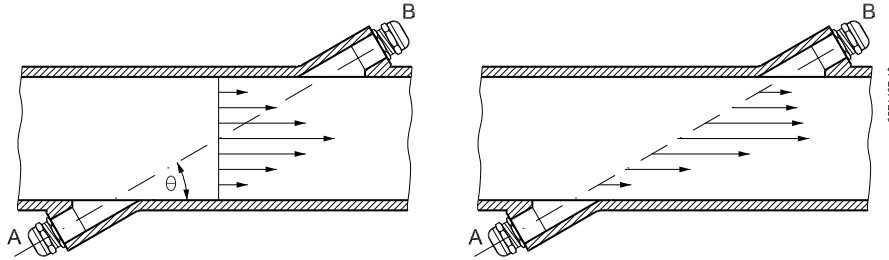

Figure 3-3 Velocity distribution along sound path

A sound wave travelling in the same direction as the liquid flow arrives at point B from point A in a shorter time than the sound wave travelling against the direction of flow (from point B to A).

The difference in sound transit time indicates the flow velocity in the pipe.

Since delay time is measured at short intervals both in and against flow direction, temperature has no influence on measurement accuracy.

SITRANS F US flowmeters

In SITRANS F US flowmeters the ultrasonic transducers are placed at an angle θ in relation to the pipe axis. The transducers function as transmitters and receivers of the ultrasonic signals. Measurement is performed by determining the time the ultrasonic signal takes to travel with and against the flow. The principle can be expressed as follows:

$$v = K \times (t_{B,A} - t_{A,B}) / (t_{A,B} \times t_{B,A}) = K \times \Delta t / t^2$$

where

v = Average flow velocity

t = Transit time

K = Proportional flow factor

This measuring principle offers the advantage that it is independent of variations in the actual sound velocity of the liquid, that is independent of the temperature.

The proportional flow factor K is determined by "WET" calibration or calculated by "AUTO" in case of manual programming of mechanical/geometrical pipe data (SONOKIT only). The transducer angle (θ), distance between sensors (L) and pipe dimension (D_i and D_o) are shown in the figure below.

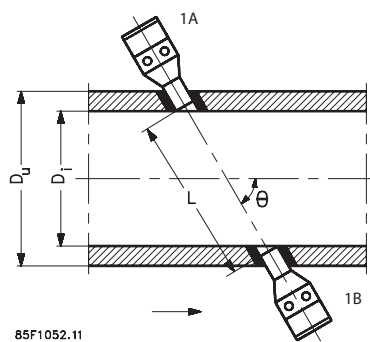

The ultrasonic signal is sent directly between the transducers. The advantage gained sending signals from point to point is an extremely good signal strength.

3.4 Measuring principle

Installing/Mounting

4.1

Introduction

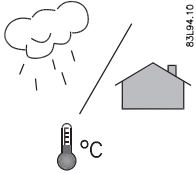

SITRANS F flowmeters with minimum IP65/NEMA 4X enclosure rating are suitable for indoor and outdoor installations.

- Make sure that pressure and temperature specifications indicated on the device nameplate / label will not be exceeded.

⚠ WARNING

Installation in hazardous location

Special requirements apply to the location and interconnection of sensor and transmitter. See Installation in hazardous locations (Page 14)

4.2 Transmitter installation

4.2.1 Standard wall-mounting bracket

Wall mounting

1. Fit the mounting bracket on the transmitter using the mounting material provided.
2. Mount transmitter with mounting plate on the wall.

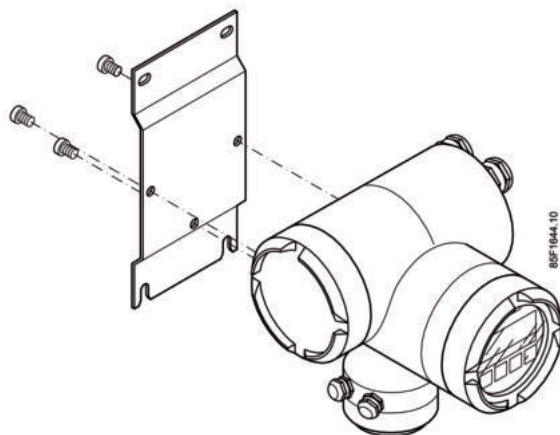

Figure 4-1 Standard wall-mounting bracket

Note

The standard wall-mounting bracket is only suitable for wall mounting.

4.2.2 Pipe or wall mounting with assembly bracket

Note

The special wall-mounting bracket is not part of the standard delivery and must be ordered separately.

Pipe mounting

1. Mount the assembly bracket on the pipe using the fastening brackets
2. Fasten the transmitter with the two screws provided.

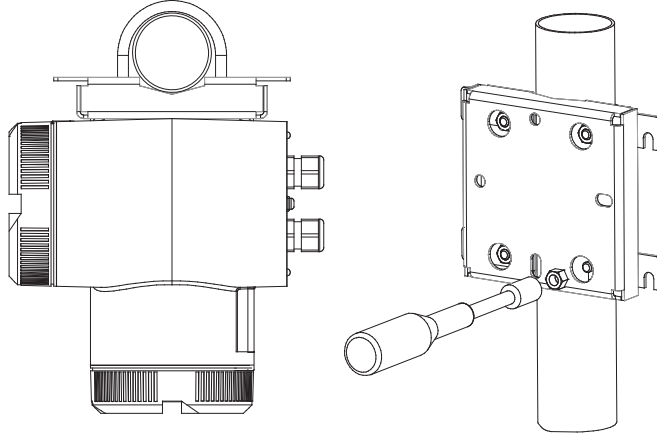

Pipe mounting with assembly bracket

Wall mounting

1. Fasten the assembly bracket to the back of the transmitter
2. Fasten the transmitter and assembly bracket to the wall

Note

The fastening brackets and nuts are not needed for wall mounting.

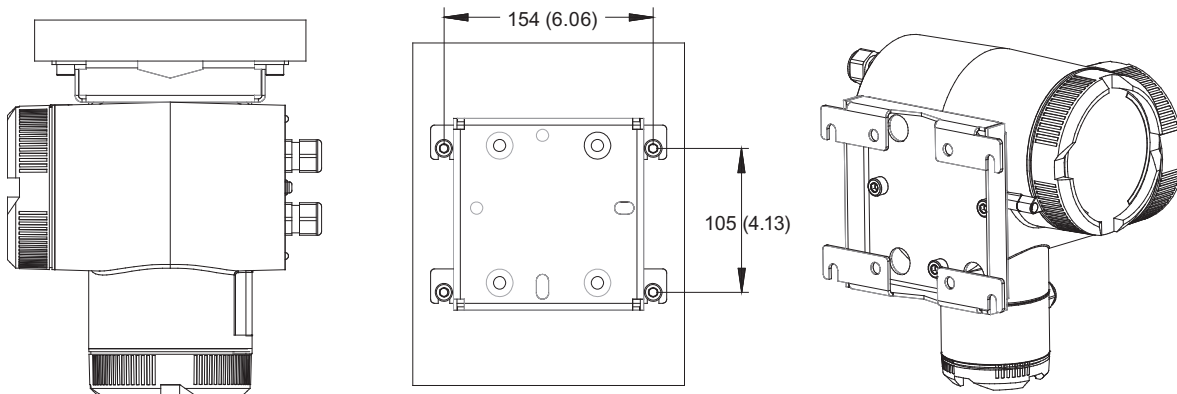

Wall mounting with assembly bracket. Dimensions in mm (inch).

4.2.3 Turning the local display

The local display can be turned in 90° steps to enable better reading in case of vertical installation or overhead assembly.

1. Switch off the power supply.
2. Release the catch on the lid of the electronics compartment with a 3 mm Allen key.
3. Unscrew the cover.
4. Carefully release the fastening hooks of the local display using a screwdriver or similar tool
5. Pull out the unit, turn it to the desired position and push it back in.
6. Screw the lid back on and mount the lid catch.

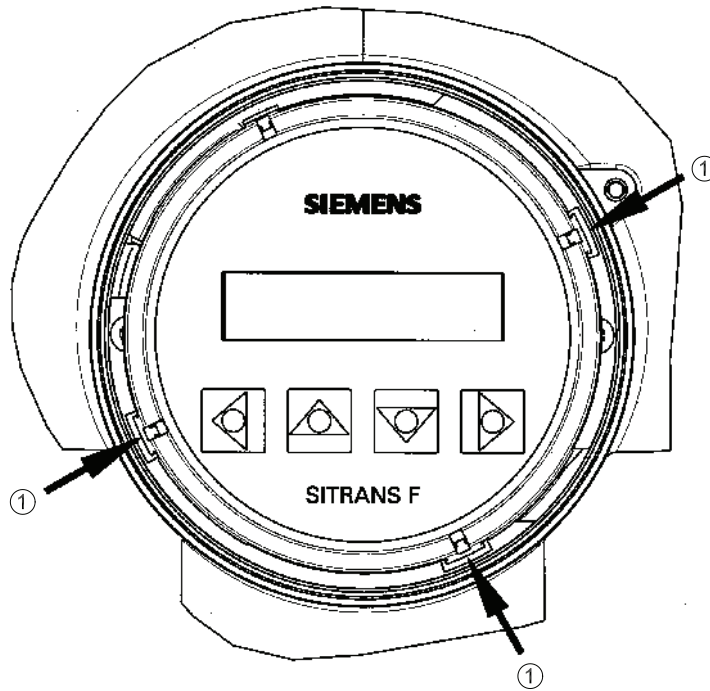

① Fastening hooks

Figure 4-2 Unlocking the fastening hooks on the local display

Connecting

This chapter describes how to wire up the device in two steps:

- Step 1: Wiring the transducer cables (Page 31)
- Step 2: Wiring output and power supply (Page 33)

Note

The connection of the transducers on the sensors type SONO 3100 and SONOKIT (both with SONO 3200 transducers) or in the terminal housing of sensor type SONO 3300 is described in the separate sensor operating instructions.

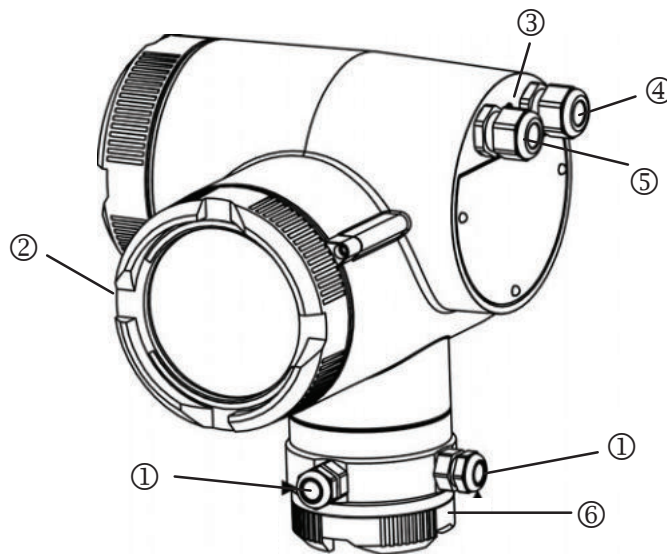

- ① Transducer cable entry (4 entries)
- ② Terminal box lid for power supply and signal cables
- ③ Potential equalization (PE connector)
- ④ Output cable entry
- ⑤ Power supply entry
- ⑥ Terminal box lid for transducer / sensor cables

Figure 5-1 Overview, Electrical connections

Safety measurements

⚠	WARNING
Qualified personnel	
Only qualified personnel may carry out work on the electrical connections.	

 **WARNING**

Use in hazardous locations

Special requirements apply to the location and interconnection of sensor and transmitter. See Installation in hazardous locations (Page 14).

 **WARNING**

Danger of electric shock!

Never install the device with the mains voltage switched on!

The version for power supply 19 to 30 V DC may only be connected to SELV or PELV circuits.

Cable specifications

- Use cables with a cross section of at least 1.5 mm² and double or reinforced insulation for the power supply.
- Lay heat-resistant cables if high temperatures can occur on the housing, for example due to conduction of heat by the sensor/metering tube. Lay the cables so that they do not come into contact with the hot sensor/metering tube.
- Lay signal cables separately from cables with voltages > 60 V.
- Use cables with twisted wire pairs.
- Earth transmitter housing on the PE connector.
- Cables used for connection must have diameters fitting the glands.
- Use shielded cables for the outputs.
- Compare data on rating plate with local power supply.

5.1 Wiring the transducer cables

1. Unscrew the bottom lid from the terminal box.

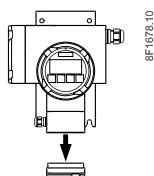

2. Connect the cables to the transducers according to type of system (1-path or 2-path, see below).

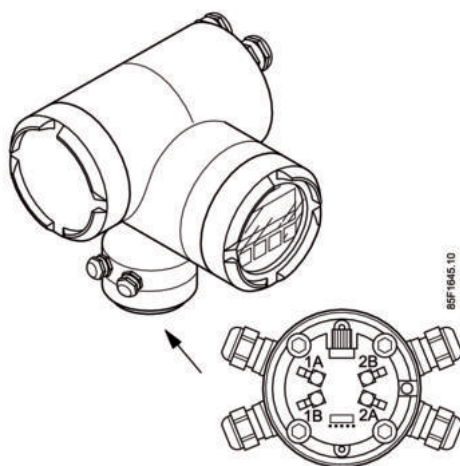

3. Carefully press the cables into the cable glands until the "snap" function fixes the cable inside the connection module. Make sure the cables are mounted correctly by smoothly pulling the cable.

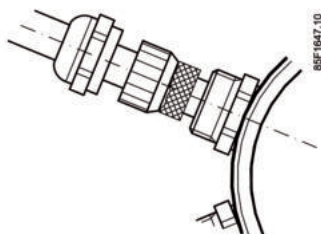

5.1 Wiring the transducer cables

- If necessary, the transducer cables can be shortened at the respective transducer / sensor end (the high temperature versions).
Make sure the cables are equal in length in order to avoid signal delays in the signal processing.

Note

The SITRANS F US sensor is shipped with 2 or 4 transducer cables of fixed lengths of 3, 15, 30, 60, 90 or 120 m (9.84, 49.21, 98.43, 196.85, 295.28, or 393.70 ft).

Note

The allowed minimum transducer cable bending radius is 50 mm.

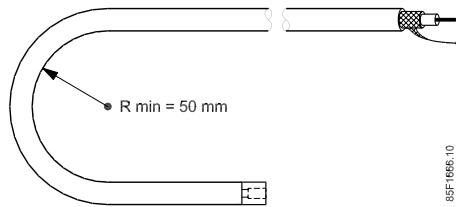

- Tighten the cable glands on the threaded bush until the cable is sealed tightly (IP65).
- Screw the lid back on.

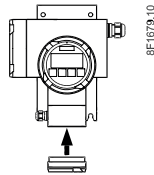

- After the installation, check and, if necessary, correct the cable length setting of the transmitter (see menu 7).

Wiring 1-path systems

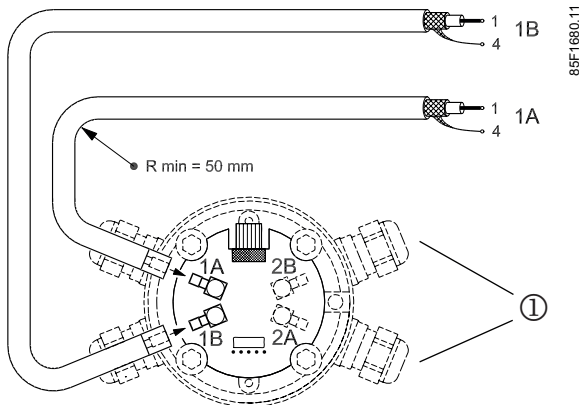

- For 1-path sensors exchange the two unused cable glands with the blind plugs.

Figure 5-2 Wiring transducer cables, 1-path system.

Wiring 2-path systems

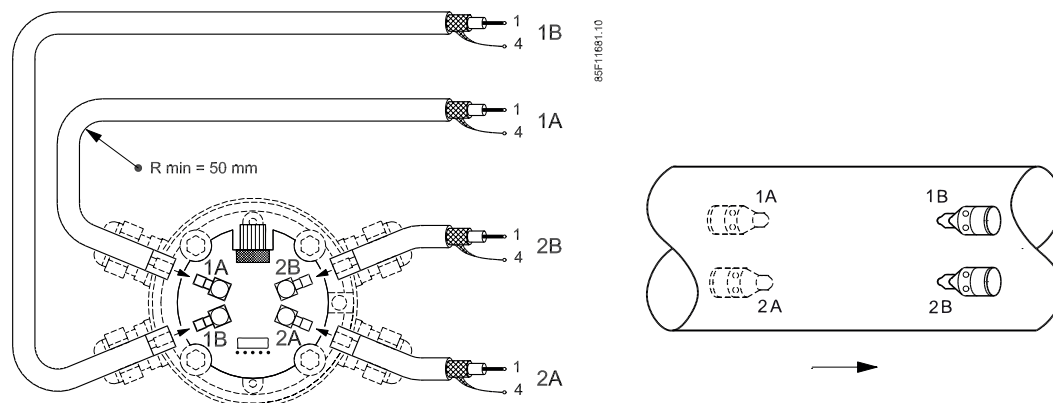
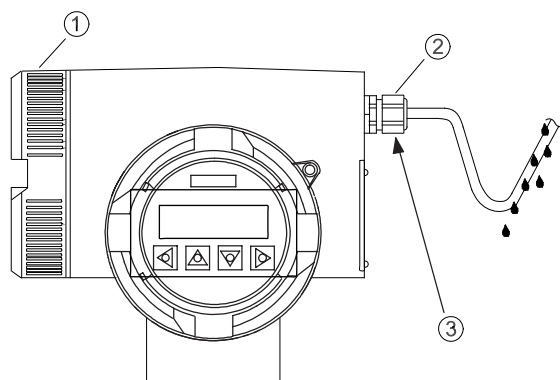

Figure 5-3 Wiring transducer cables, 2-path system

5.2 Wiring output and power supply



- ① Lid of terminal box
- ② Cable gland
- ③ PE connector - between the cable glands

Figure 5-4 FUS060 with layed cables

1. Release the lid of the terminal box by turning the 3 mm hexagon socket screw.
2. Unscrew the lid.
3. Push the power cable and signal cable through the cable glands up to the terminal block.

4. Make the connection according to the following schematics.

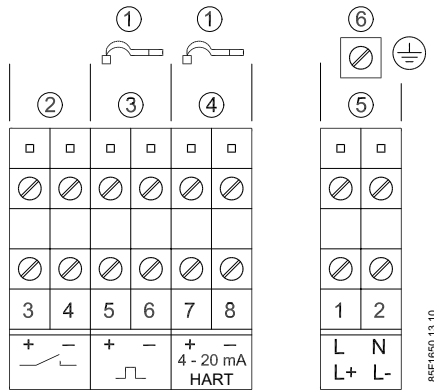

- ① Ground connection shield
- ② Digital output 2 (relay) or digital input
- ③ Digital output 1 (active / passive)
- ④ Analog output (active) to 4-20 mA; HART
- ⑤ Power supply, L/N = 115 ... 230 V AC; L+/L- = 19 ... 30 V DC / 21 ... 26 V AC
- ⑥ Terminal for PE conductor

Intrinsically safe circuits must be separated from non-intrinsically safe circuits by certified safety isolators or barriers.

For reliable communication via HART protocol the load in the signal circuit must be at least 230 Ω.

The FUS060 enclosure must be connected with an earth wire to the PE connector.

NOTICE

Both transmitter and sensor must be grounded for optimal performance

The PE-terminals on the FUS060 and on the sensors (SONO 3200 transducers, SONO 3100 or SONO 3300) must be connected to the local equipotential bonding system (min. 4 mm²).

Note

- Use signal cables with shielded wire pairs if analog output and pulse/frequency output are to be used simultaneously and signals are transmitted in one cable.
- For full performance at 10 KHz frequency on digital output 1, the capacitive load should not exceed 100 nF, for Ex version see Installation in hazardous locations (Page 14).

5. Fit end ferrules to fine wire cables.
6. Connect PE cable of power supply to earth terminal in terminal box. Use a cable length so that the PE conductor is the last one to come away when the cables are pulled.
7. Mount lid for power supply terminals.
8. Tighten the cable glands and check strain relief.
9. Lay cables in a bend in front of the cable glands to prevent moisture getting into terminal block.
10. Replace unused cable glands with certified blanking plugs.

11. Screw the lid tightly on to the housing by using a tool. The sealing ring must be clean and undamaged.
12. Remount the lid lock.

Commissioning

 WARNING
Dangerous high voltage
Certain parts inside the device carry dangerous high voltage. The housing must be closed and grounded before switching the device on.

 WARNING
Operation with high pressure and corrosive media
The sensor connected to this device can be operated with high pressure and corrosive media. Therefore improper handling of the device can lead to serious injuries and/or considerable material damage.

6.1 Start up

Upon power-on the device runs a self-test which lasts about 30 seconds. Immediately after the self-test, the device is ready for operation. Be aware that a number of factory settings (for example max. volume flow, angle of paths, distance between transducers, and displacement of transducer from center line of pipe) are dimension dependent. The settings are stored from factory in the transmitter for SONO 3100 and SONO 3300. For SONOKIT and spare part transmitters, enter values manually; see Keying in sensor data (Page 68). If there is still gas/air in the pipe (metering tube) or in the pipeline after assembly, a flashing "F" or "D" can appear at the top right of the first line in the display, see Diagnostics (menu 2) (Page 49) and Table 9-1 Error symptoms (Page 71). The failure signal is output at the output.

6.2 Operating the device

The device can be operated in the following ways:

- Local display (LUI)
- HART
- SIMATIC PDM (PC/laptop)

6.3 Commissioning via local user interface

6.3.1 Operating via local display

The device is operated with the optical keypad on the operating and display panel. The keypad are operated by touching the appropriate fields on the glass panel with your fingertips. The individual device functions/parameters are selected and changed by alternately actuating the optical keypad with the menu-guided operation in the display.

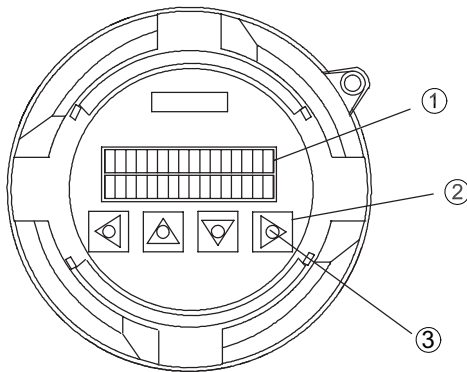

- ① Display (LCD) - 2 lines of 16 characters
- ② Optical keypad
- ③ Infrared key

Figure 6-1 Keypad and display layout

For settings options for the automatic backlight function, see menu 1.1.5.

Note

IP protection

Operation does not require opening of the device. This means that a high degree of protection is guaranteed at all times.

6.3.2 Operating via HART communication

The device can be operated using a HART communicator or a HART-based controlling system.

Electrical connection of the PC/laptop with HART modem and HART communicator to the 4 to 20 mA signal line is shown in figure below.

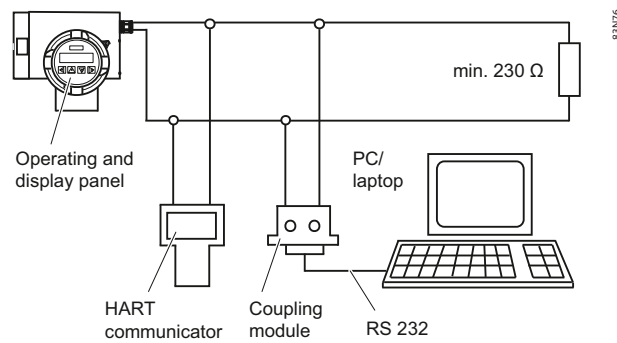

Figure 6-2 Operating via HART communication

⚠ WARNING
Use in hazardous locations
Do not use the coupling module (HART modem) in hazardous locations and do not connect to intrinsically safe circuits.

BUS addresses





Make sure that each device ID (HART address) is set before operating two or more field devices on the bus. The HART protocol specifies a short address and a long address for each device. The long address is unique for each device and is setup in the factory. The short address is set by the user and it must be different for each device on the bus. The range of addresses is from 0 to 15, default setting is 0, see menu 5.3 in Menu 5 - Identification (Page 111).

Note

HART multidrop communication is not supported

6.3.3 Navigating the menu



The device functions and parameters available are shown in the second line of the display.

- Selection is made with the  and  keys. These are shown in the second line of the display.
- Enter device function or setting level of parameters with the  key (Enter function).
- Exit the selected function or setting level without storage of the change by using the  key until the cursor key moves to the far left position.

Changing parameter settings



The currently valid setting appears after selecting the setting level of a parameter. If programming is enabled, the programmable value flashes in the second line of the display. The parameter setting can be changed. There are two different types of data input:

- Direct numerical input
- Input from given table

In the numerical input, the  and  keys function as cursor control. The selected digit flashes.

The  key increases the flashing digit (for example 9 9 . 0 0 0 becomes 1 0 0 . 0 0 0).



The  key decreases the flashing digit (for example 1 0 . 0 0 0 becomes 9 . 0 0 0).

The decimal point is moved to the right using the  key and to the left using the  key.

After selecting the last digit, the input is confirmed by using the  key. The entered value is accepted if it is within the permissible input range. In this case the user guidance returns to the selection menu for the parameters of the group concerned. If the entered value is rejected, an error message briefly appears on the display followed by the previous setting. The value can be changed again.

When switching between different units a rounding-off may need to be corrected manually.



Note

If the  or  keys are operated permanently (finger left on the glass panel), the numeric value or setting option is changed continuously in tabular selection.

If an accidentally changed setting is wrong, it is possible to exit the menu item by pressing the  key several times (return to the menu one level up).

6.3.4 Write protection

Programming of the device by unauthorized persons can be prevented by using a personal, freely selectable code (not "0") in the operating and display panel. Device functions and parameters can then only be changed after entering the code. The personal code is set in the menu 6.2 Customer code.

If the  and  keys are actuated in the parameter setting level, the request to enter the code appears in the display. For free access, it is also possible to enter the code once in menu 6.1 Enter code.

The programming is disabled again:

- After returning to the display mode
- About 10 minutes after actuating the last optical keypad
- After entering any number, not the personal code, in menu 6.1 Enter code

Note

The programming is permanently enabled with code = 0 (factory setting).

See also

The exact structure of the operating menu is explained in the appendix HMI menu structure (Page 103). The main functions are described in Functions.

See also

Functions (Page 47)

6.3.5 Operating examples

The operating paths to be followed are represented in each diagram.

The optical keypads to be actuated are specified and the individual operating steps numbered consecutively.

Example 1 - Setting of menu language

Starting point is the multi-display

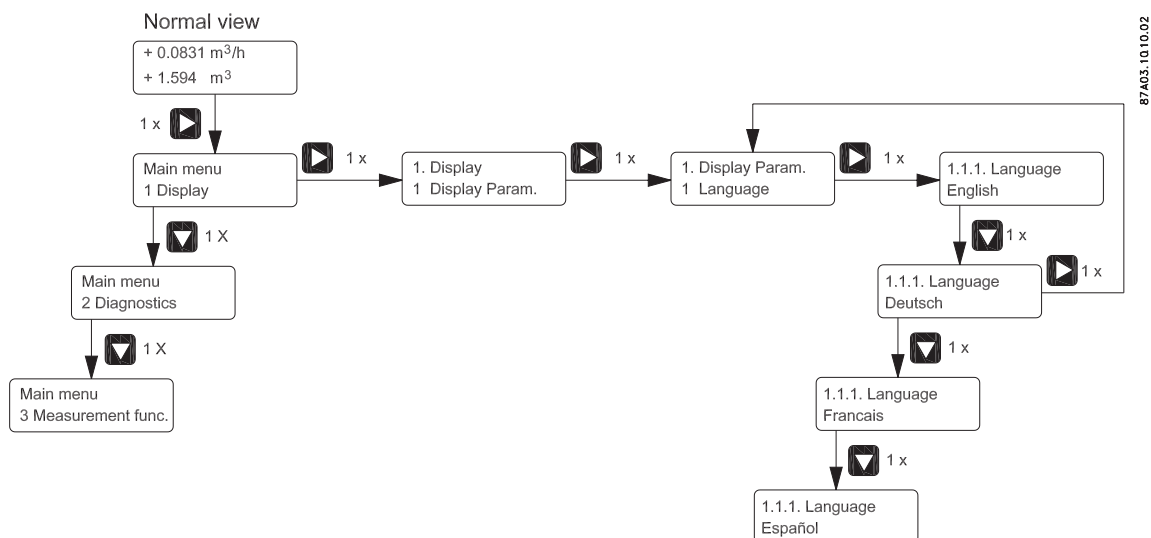

Figure 6-3 Changing language from factory-set "English" to "German (Deutsch)"

Example 2 - Changing the display flow unit

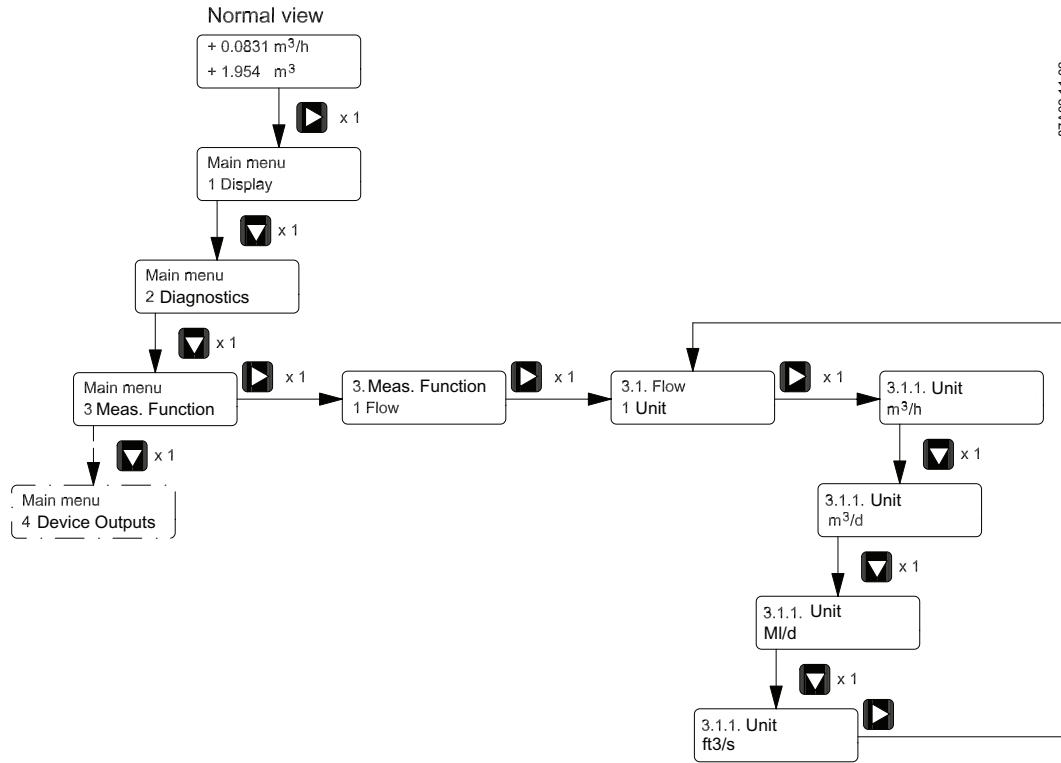

Figure 6-4 Changing the flow value unit from m³/h to ft³/s

Example 3 - Changing the pulse unit

Starting point is the sub-menu 4.2.3 (Pulse value)

Currently valid setting appears in display.

4.2.	D	i	g	i	t	a	l	o	u	t	p
3	P	u	l	s	e	v	a	l	u	e	

1 x

Enable programming.
Unit in second display line flashes.

4.2.3	U	n	i	t							
l	/	l	i	m	p						

1 x

Digit 1 flashes.

4.2.3	P	u	l	s	e	R	a	t	e		
+	1	.	0	0					l	/	l

1 x

Change digit from 1 to 2 with

4.2.3	P	u	l	s	e	R	a	t	e		
+	2	.	0	0					l	/	l

1 x

Select decimal point with

4.2.3	P	u	l	s	e	R	a	t	e		
+	2	.	0	0					l	/	l

2 x

Move decimal point two places to the right
by pressing twice.

4.2.3	P	u	l	s	e	R	a	t	e		
+	2	0	0	.	0	0			l	/	l

3 x

Select last position of number with
and terminate input by pressing
(Enter function).

4.2.	D	i	g	i	t	a	l	o	u	t	p
3	P	u	l	s	e	v	a	l	u	e	

6.4 Commissioning via SIMATIC PDM

SIMATIC PDM (Process Device Manager) is a software package for configuring, parameterizing, commissioning, and maintaining field devices (for example transducers).

6.4 Commissioning via SIMATIC PDM

Among other features, SIMATIC PDM contains a simple process for monitoring process values, interrupts and status/diagnosis signals of a field device.

Note

For instructions on installation and operation of SIMATIC PDM, refer to the SIMATIC PDM Getting Started (included in the documentation package that comes with PDM).

Note

Minimum PDM version required is SIMATIC PDM V6.0 + SP5

6.4.1 Configuration

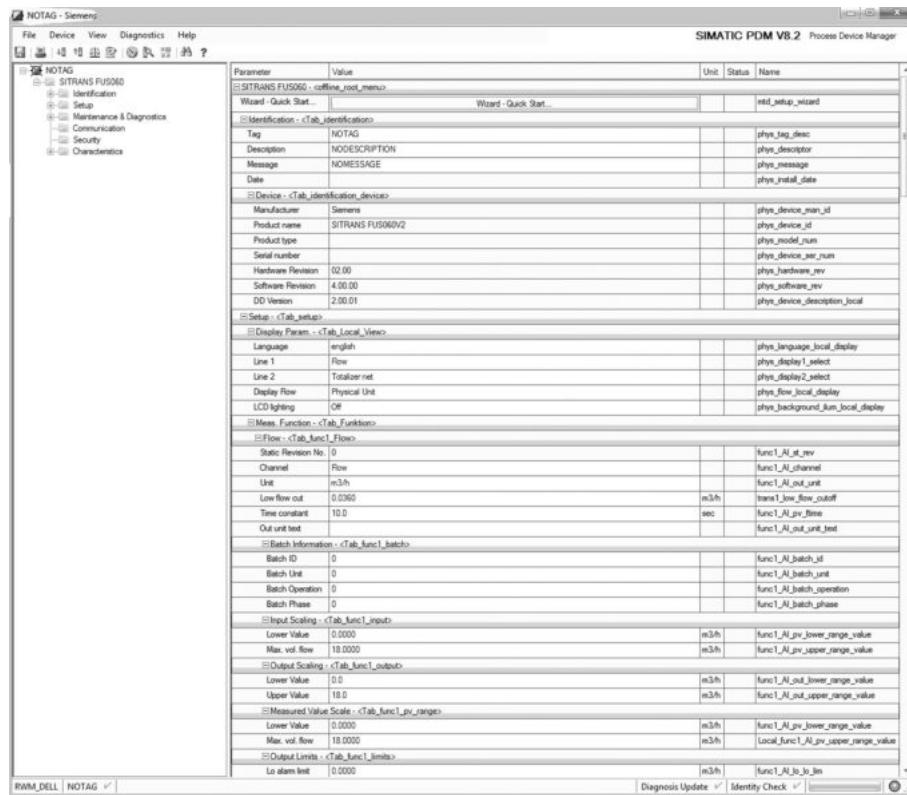

Figure 6-5 FUS060 HART via SIMATIC PDM (example)

Note

Special characters

Some special characters are not supported via the SIMATIC PDM communication. In case of uploading such into the FUS060 a "?" is displayed instead. A "Ü" is changed to "ü" in the device display.

Commissioning steps

The commissioning is divided into the following steps:

1. Installing and connecting in the HART adapter.
2. Installing the device driver (download from EDD download (<http://support.automation.siemens.com/WW/view/en/24481552/133100>)).
3. Adding the device to the SIMATIC PDM network.
4. Configuring the device.
5. Optimizing the system.
6. Checking the operation readiness.

Functions

Operation is based on a hierarchically structured operating concept. All functions/parameters are grouped logically and carry a menu number.

The seven main functions are selected in the main menu:

- Display (menu 1) (Page 47)
- Diagnostics (menu 2) (Page 49)
- Measuring functions (menu 3) (Page 50)
- Device outputs (menu 4) (Page 53)
- Identification (menu 5) (Page 58)
- Service (menu 6) (Page 59)
- Sensor parameters (menu 7) (Page 61)

The following section only describes how to manually operate the menus for the device settings.

7.1 Display (menu 1)

Language (menu 1.1.1)

Set display language (English, Deutsch, Francais, Español)

Line 1 (menu 1.1.2)

Set parameter value in line 1 (upper line on the display). Default is Flow.

Line 2 (menu 1.1.3)

Set parameter value in line 2 (lower line on the display). Default is Totalizer forward.

Display flow (menu 1.1.4)

Select the presentation of flow value (Physical Units (default), in % or Bar Diagramm (in %))

LCD lighting (menu 1.1.5)

Set the backlight turn-off. At power-off this function is automatically reset to the default value Off.

Off: At infrared key operation, the light turns on automatically and off again 10 minutes after last key action.

7.1 Display (menu 1)

On: At infrared key operation, the light turns on automatically and stays on for 1 hour after last key action. Then it turns off.

Multi-Display (menu 1.1.6)

Shows the display with the settings done in menus 1.1.2, 1.1.3 and 1.1.4.

Flow (menu 1.2)

Shows the actual flow.

Totalizer (menu 1.3)

The actual totalizer readings are displayed with the correct sign, that is reverse totalizers with a minus sign. The three totalizers are shown in submenus 1.3.1, 1.3.2 and 1.3.3.

Settings (all) (menu 1.3.4)

Reset+stop: All quantity totalizers are set to "0" and stopped. The totalizer for the error count (menu 6.5.4) is set to "0" but not stopped.

Reset+start: All totalizers are set to "0" and started.

The totalizers can also be controlled individually (menus 3.4.3, 3.5.3 and 3.6.5).

Flow velocity (menu 1.4)

Actual average flow velocity in metering tube (in m/s)

Sound velocity (menu 1.5)

Actual sound velocity in medium (in m/s (default) or in ft/s)

Amplitude US (menu 1.6)

Relative ultrasonic amplitude of received ultrasonic signals (reference water) (in %)

Frequency and Current output (menus 1.7 and 1.8)

The arithmetically calculated output values are displayed in the menu 1.7 Frequency (in Hz) and in menu 1.8 Current Output (in mA), irrespective of whether the output is used.

7.2 Diagnostics (menu 2)

Device status (menu 2.1)

The test routines are systematically executed during normal operation. The error is indicated by a blinking letter on display:

D: Device error

F: Process error

S: Simulation is active

The error can also be signaled on the analog and digital outputs.

The error is shown in menu 2.1 Device status. The error messages and their assignment to the blinking letter, the analog output and the digital outputs are listed in the table.

Table 7-1 Error messages

Error message	Blinking letter on the display	Error message on	
		analog output	digital outputs 1 and 2 (relay)
Measuring path error	F	✓ ³⁾	✓
Unreliable flow value	F	✓ ³⁾	✓
P/F too high	F	✓ ³⁾	✓
US gain too high	F	✓ ³⁾	✓
Simulation active	S	-	-
COM module failure ¹⁾	D	-	-
Measurement module failure	D	✓	✓
EEPROM failure	D	✓	✓
RAM failure	D	✓	✓
SSC failure ²⁾	D	-	✓
Firmware failure	D	✓	✓

¹⁾ HART module

²⁾ Internal serial interface

³⁾ Failure signal is not output if error is suppressed and simulation function is active

Suppress error (menu 2.2)

In this menu item the error(s) "Unreliab. Flow" and/or "Meas path err." can be suppressed so that the suppressed error(s) are not shown, neither on the display nor at the output. After every reset or power off of the device, all error messages are available again, thus this menu setting is not stored.

Device test (menu 2.3)

The following test sub routines are available:

7.3 Measuring functions (menu 3)

Self test (menu 2.3.1)

The self test routines test the hardware and have a duration of about 10 seconds.

If there is no error, "OK" is displayed, otherwise "not OK". The type of error can be read in the menu 2.1 Device Status.

Display test (menu 2.3.2)

The LCD is checked with this menu item. The display is dark for about 5 seconds and then bright for about 5 seconds.

Simulation (menu 2.4)

The display and output values to be simulated can be selected in individual submenus. The setting becomes active after confirming the selected value. If an error is pending, only the display value can be simulated. The output will continue to indicate an error signal unless the errors are suppressed, see menu 2.2 Suppress err. (Both). The two warnings "P/F too high" and "US gain too high" do not influence the outputs during the simulation. An active simulation is indicated on the display by a blinking letter S.

7.3 Measuring functions (menu 3)

Flow, Sound Velocity and Amplitude US (menus 3.1, 3.2 and 3.3)

In this menu the three measuring values Flow (menu 3.1), Sound Velocity (menu 3.2) and Amplitude US (menu 3.3) are parameterized.

All submenus (menu 3.x) are divided further for setting of subsequent values:

- Unit
- Range (Lower Value (for Flow not selectable - always 0) and Upper Value)
- Limits (Lo alarm limit, Hi alarm limit and Hysteresis)
- Time constant (damping)

Note

When switching between different units a rounding-off may need to be corrected manually.

Density (menu 3.1.4)

After entering units the display will automatically step into Density.

The density unit and value entered in this menu are used to convert the volume flow to mass flow (see also menu 3.1.1 Unit).

Note

Input of density is unnecessary and ineffective when volume flow unit has been selected in menu 3.1.1 Unit.

Flow direct (menu 3.1.5.1)

In this menu the setting of the main flow direction can be changed.

Meas. direct (menu 3.1.5.2)

The device is able to measure in both flow directions (forward and reverse) or in forward direction only.

The possible settings are:

- Forward + reverse
- Forward only

If "Forward only" is selected, signals are output or accumulated internally for a flow in this direction only.

Pulse and frequency are always displayed as absolute values (no negative values).

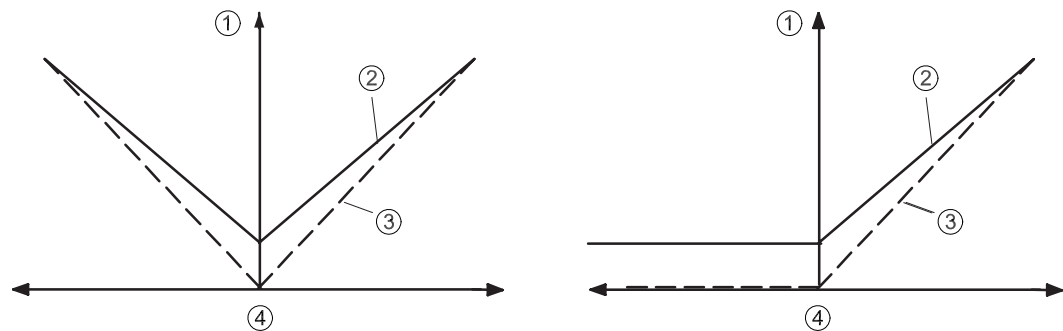

Left figure: Forward and reverse flow. Right figure: Forward flow only

- ① Output signal
- ② Analog output
- ③ Pulse/frequency output
- ④ Flow

Hysteresis (menus 3.1.5.3, 3.2.3.3, 3.3.2.3 and 3.6.4)

Signaling of measured values can operate with a hysteresis set by the user. The setting is made in % of full scale value. If, for example, the hysteresis is 1% (default), the relay contact does not switch until flow is -1% of full scale value and it returns to its original position when flow is +1% of full scale value.

7.3 Measuring functions (menu 3)

The operating principle of the digital output 1 (menus 4.2.x) for flow direction is set in menus 4.2.2 and 4.3.2 Signal Type.

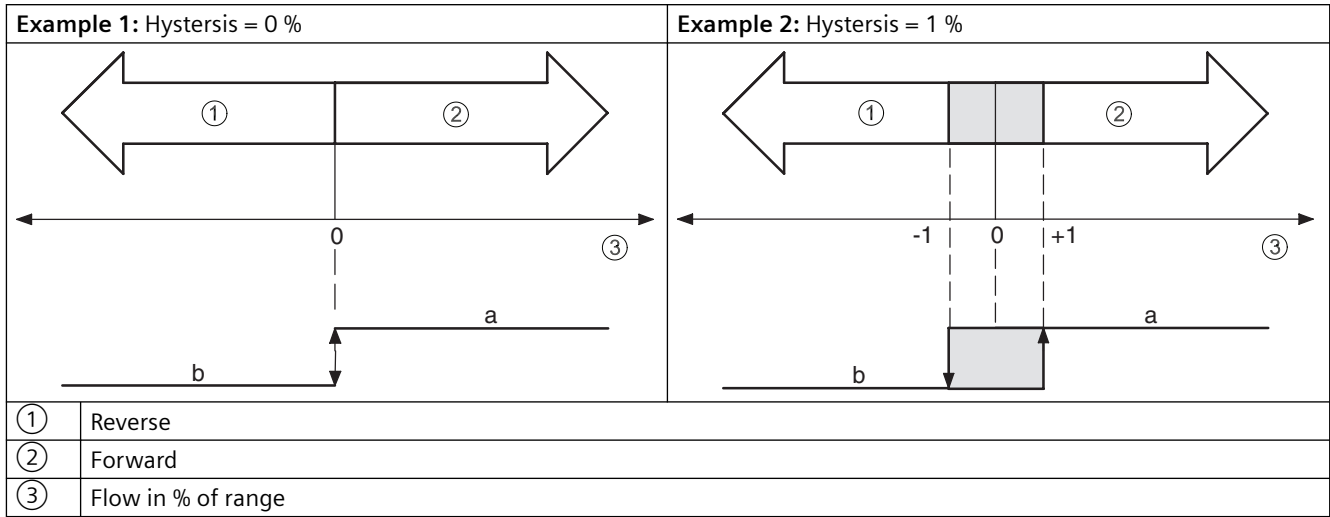

Selected setting	a/b	Output function
Contact closes	a	Relay contact closed
	b	Relay contact open
Contact opens	a	Relay contact open
	b	Relay contact closed

The other hysteresis menus are of the same principle.

Note

The low flow cut-off suppression has no influence on signaling of flow direction.

Low Flow Cut (menu 3.1.6)

The residual flow is an absolute value in flow units and is not automatically converted when the scaling changes.

Totalizer (menus 3.4, 3.5 and 3.6)

The totalizers have fixed counting direction settings. The counting direction cannot be changed. The totalizers directly accumulate the physical measured values according to the negative or positive sign, that is the reverse totalizer only accepts negative values.

The reading of the net totalizer is accumulated from the flow values with the correct sign and is not calculated from the difference of the values of the forward and reverse totalizer. If individual totalizers are not reset or started at the same time, the reading on the net totalizer may deviate from the difference between the forward and reverse totalizer values.

Unit (menus 3.4.1, 3.5.1 and 3.6.1)

The units can be entered separately for each totalizer. When there is a switchover between mass and volume flow (by switching between massflow unit and volume flow unit in menu 3.1.4), the totalizer readings will automatically be converted according to the density entered in menu 3.1.4. The unit is also automatically converted to the unit last set for the corresponding type (volume or mass).

Note

The selected display unit is also the unit on the fieldbus output.

Limits (menus 3.4.2, 3.4.3, 3.5.2, 3.5.3, 3.6.2 and 3.6.3)

The same instructions apply to limits with quantity totalizers as to the output scales (see above). Totalizer readings and assigned limit values should also be considered according to positive (Hi limit alarm value is greater than the Lo alarm limit value) or negative sign (Lo limit alarm value is greater than the Hi alarm limit value)!

The hysteresis is only evaluated with the net totalizer as value fluctuations are only possible there.

7.4 Device outputs (menu 4)

In these menus the three device outputs (analog output, digital output 1 and digital output 2) are parameterized.

The analog output (terminals 7+ and 8-) can indicate flow, sound velocity and US-amplitude.

Note**Important**

The analog output is only active for devices with HART interface.

The digital output 1 (terminals 5+ and 6-) can indicate pulse, frequency, alarm, status and limits.

The digital output 2 (terminals 3+ and 4-) can indicate alarm, status or limits.

Analog output (menu 4.1)

(Terminals 7+ and 8-)

In this menu the measuring value (flow, sound velocity or US-amplitude) is assigned to the output and the upper current limit for the output signal as well as the error signal are set.

Digital outp 1 (menu 4.2)

(Terminals 5+ and 6-)

In this menu the output function (pulse, frequency or alarm/limits) is assigned and the signal type as well as the pulse/frequency parameters are set.

Depending on the selected function (menu 4.2.1) either the pulse value and pulse width (menus 4.2.3 and 4.2.4) or the full scale frequency (menu 4.2.5) settings will affect the output.

The digital output 1 can indicate flow (impulse or frequency) and some alarms/limits.

Function (menu 4.2.1)

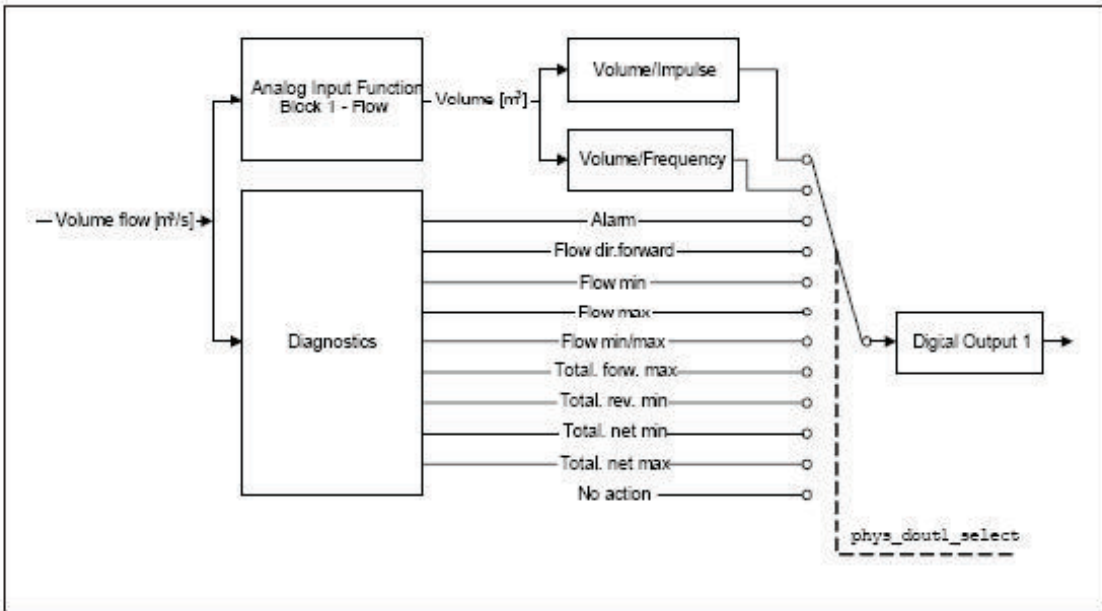

Figure 7-1 Function block diagram

In the "Pulse" and "Frequency" functions the flow is converted into a binary signal at the digital output:

In the "Pulse" function a pulse sequence corresponding with the forward net flow is issued. Each pulse corresponds to a net flow according to the set Pulse value (menu 4.2.3). The maximum number of pulses per time unit is reached with a flow to the extent of the upper value on the flow measuring scale (menu 3.1.2). Higher flow values can no longer be taken correctly into consideration at the pulse output. No pulses are issued when flow = 0.

In the "Frequency" function a constant signal with a frequency proportional to the current flow value (output value) is issued. The frequency 0 corresponds to the lower value, the set upper frequency to the upper value of the output scale (menu 4.2.5). Flow values below the lower value are issued with the frequency 0.

If the flow exceeds the upper value on the measuring scale, the digital output can no longer correctly issue the required number of pulses or the frequency and a pulse/frequency error message ("P/F too high") will appear.

If the pulse/frequency error message appears, it is required to adjust the pulse settings (menus 4.2.3 and 4.2.4) or the full scale frequency (menu 4.2.5).

Signal type (menu 4.2.2)

Different signal types can be configured for the digital output 1:

- Active:
the device-internal voltage is applied to terminal 7+ and 8- (24 V DC).
- Passive:
external power supply is required.

Note

For Ex versions only passive mode is supported. If Signal type is set to Active, it will function as Passive.

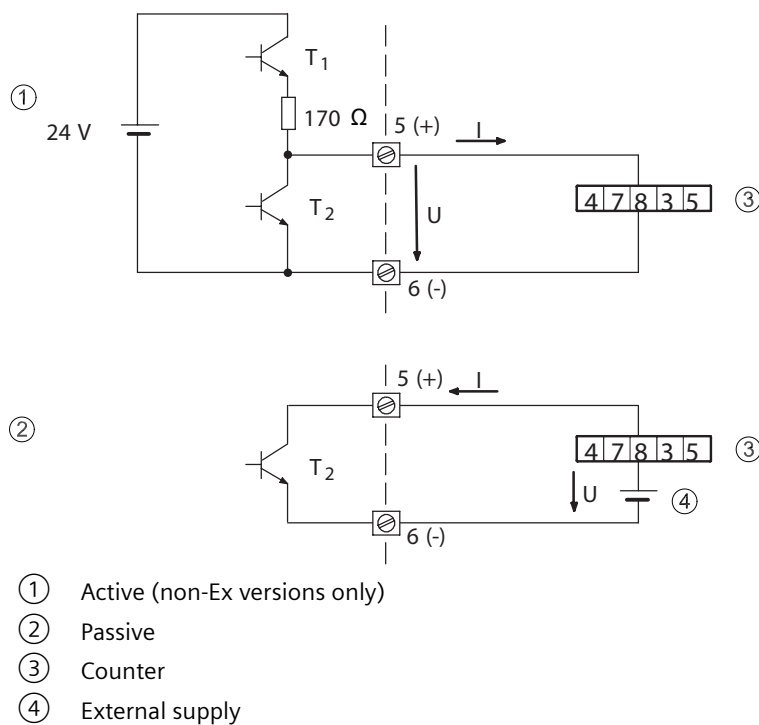

Figure 7-2 Active and passive signals

Signals with positive and negative logic can be generated (positive or negative pulses).

The figure below illustrates the setting options.

7.4 Device outputs (menu 4)

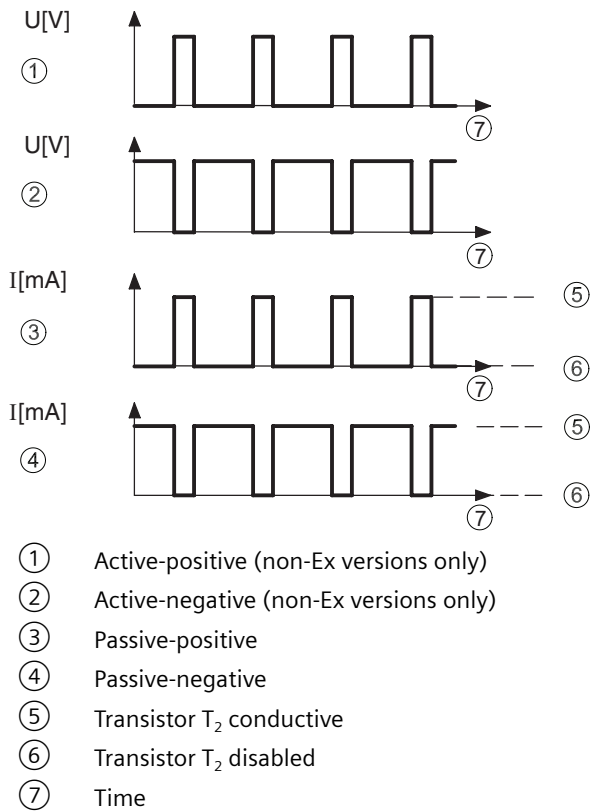

Figure 7-3 Signal types for digital output 1

Pulse value (menu 4.2.3)

There are two parameters to be set for the pulse output in this menu:

- Unit
The physical unit (unit/pulse).
- Pulse rate
Number of mass/volume units per pulse.

Pulse width (menu 4.2.4)

You can set the pulse/pause ratio of the pulse output with the pulse width. The pulse width can be set in a range from 0.1 to 2000 ms. A maximum pulse width is calculated in relation to the set full scale value and the set pulse valence. The maximum pulse frequency is 5 kHz.

Full scale frq (menu 4.2.5)

The frequency is permanently assigned to the flow. The pulse/pause ratio is constant 1:1. If the "Frequency" function is selected, the "Full scale frq" is set in the range from 2 to 10 000 Hz.

Digital outp 2 (menu 4.3)

(Terminals 3+ and 4-)

In this menu the digital output 2 (relay) is configured as an alarm or status output.

The function of the relay is as follows:

- Contact closes:
 - Relay contact closes at function selected in menu 4.3.1:
 - Alarm message
 - Flow in forward-direction
 - Limit signal
- Contact opens:
 - Relay contact opens at function selected in menu 4.3.1:
 - Alarm message
 - Flow in forward-direction
 - Limit signal

Setting	No alarm Reverse flow No limit signaling	Alarm message Forward flow Limit signaling
Contact closes		
Contact opens		

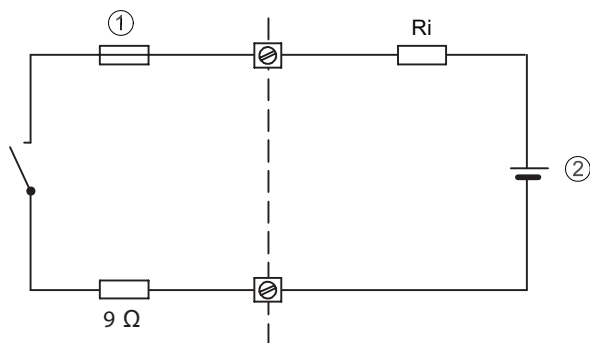

- ① Electronic fuse
- ② External supply
- Ri Internal resistance of connected system

Figure 7-4 Digital output 2

⚠ CAUTION
<p>Electronic fuse</p> <p>At high inductive loads, the digital output must be protected against transient overvoltage with a suitable external recovery diode.</p> <p>The electronic fuse is tripped in the event of overloading. The recovery time of the fuse is a few minutes. The relay contact is open in the no-load state.</p>

7.5 Identification (menu 5)





In this menu the device-specific data can be entered or read.



Unit identity (menu 5.1)

You can call or enter device-specific or TAG-related data in this menu.





You have the following options:

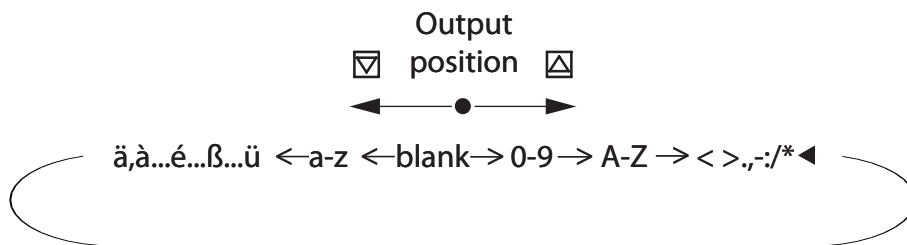

- TAG number, menu 5.1.1 (max. 8 characters)
- TAG description, menu 5.1.2 (max. 16 characters)
- TAG message, menu 5.1.3 (max. 32 characters)



TAG-specific data can be entered in these menus. The  and  keys function as cursor control. Numbers, letters and text characters are selected with the  and  keys.

If no text is stored, a "<" is displayed. By actuating the  and  keys, the "<" moves one position to the right and a character can be selected from the character set. The following characters are available:





The selected character is entered by actuating the  key and the "<" flashes again. The next character can then be selected with the  and  keys. The text input is finalized by actuating the  key when the "<" flashes.

For texts longer than 16 characters the marks < and > in the most left and/or the most right position of the display indicate that there are further characters to the left and/or right of the displayed text section. These are displayed by actuating the  and  keys.

You delete text by selecting the "<" from the character set with the  and  keys and then actuating the  key. All inputs to the right of the end of text character are then deleted.

Note

Scrolling through the characters

If the  and  keys are actuated continuously (finger continuously touching the glass panel), the characters are automatically scrolled.

Manuf. Ident. (menu 5.2)

The product-specific identification data can be read in the following submenus:

- Product type (menu 5.2.1)
- Serial number (menu 5.2.2)

- Software rev. (menu 5.2.3)
- Manuf. date (menu 5.2.4)
- Nominal size (menu 5.2.5)

Note**Nominal size**

The nominal pipe size is entered in menu 5.2.5. It is only a piece of information and has no influence on the measured values. It is not possible to change the nominal size without the factory code.

HART address (menu 5.3)

True identification of the device.

7.6 Service (menu 6)

This menu offers service and diagnostics parameters for maintenance purpose.

Note**Backlight settings (LCD lighting)**

Off: Light turns off 10 minutes after last key action.

On: On for 1 hour after last key action.

Enter code (menu 6.1)

Programming of the device by unauthorized persons can be prevented using a personal code (range 1 to 9999; max. four digits). By entering the correct code in this menu, the programming is enabled and the device settings can be changed.

If you have forgotten the code, enter 3333 in menu 6.1 and the personal code will be displayed for 5 seconds.

Customer Code (menu 6.2)

The four-digit personal code number can be created in this menu. The local write protection is activated for values > 0, that is menus can still be accessed but parameters cannot be changed.

The write protection is automatically enabled the next time the system is switched to the initial operating view.

Note

Attention

Programming is permanently enabled as long as the code is 0.

Service code (menu 6.3)

The calibration data and factory settings of the device are protected by a service code. The relevant menus are available only after entering this service code. For normal operation it is not required to enter the service code.

Reset (menu 6.4)

A reset of the unit can be made without change of parameters (warm restart). Totalizers are **not** reset.

Control values (menu 6.5)

In this menu, device-internal data used mainly for diagnosis for the used paths can be read. The values displayed in the individual menu depend on the respective application (medium). The following data are available:

- Gain
- Amplitudes
- Trigger level
- Error count %
- Time of flight - up (TOF up)
- Time of flight - down (TOF down)
- Difference in time of flight (delta TOF)

Gain (menu 6.5.1)

Every transducer gain level can be read.

These parameters are read only values and within the range of 0 to 255.

Unused paths will show 0. Normal values are in the range of 40 to 100. High gain values refer to a high sound absorption in the medium (maximum 255 for no sonic transfer, for example by empty pipe or if no sensor cable is connected).

Amplitudes (menu 6.5.2)

Each value shows the ultrasonic peak amplitude of the individual transducer in digital units from 0 to 255 corresponding to 0 to 5 V. Optimal values are between 95 and 100. Worst possible values are close to 0, for example by empty pipe or if no sensor cable is connected.

Trigger level (menu 6.5.3)

Each trigger level is used to recognize the ultrasonic signal. The trigger levels are calculated from the last signal level amplitudes. Typical values are between 40 and 100. Worst possible values are close to 128.

Error count % (menu 6.5.4)

The menu shows the error counter in % for each pat. The optimal value is 0. Worst possible values are close to 100, for example by empty pipe or if no sensor cable is connected.

TOF up and TOF down (menus 6.5.5 and 6.5.6)

The time of flight (TOF) is the time in ns the ultrasonic signal takes to travel from one transducer to the other.

The time of flight is dependent on sensor size, angle, media, and temperature of the media.

Delta TOF (menu 6.5.7)

The time of flight difference is the measured difference in ps: TOF up – TOF down. The typical value is 1000 ps for a flow velocity of 0 m/s.

Zero Trim

In this menu a manual zero trim can be performed.

Note**Zero trim conditions**

Zero trim should only be done at an absolute flowrate of zero.

7.7 Sensor parameters (menu 7)

In this menu the sensor-specific data is stored.

Note**Flowmeter systems with SONO 3100 or SONO 3300**

All sensor characteristics in menu 7 are determined and preset at the factory. They should not be changed for flowmeter systems with sensor types SONO 3100 and SONO 3300.

Note

Flowmeter systems with SONOKIT

The FUS060 transmitter is preset at the factory according to the SONOKIT order codes (for example pipe dimension and number of paths). The exact sensor pipe dimensions based on the SONOKIT sensor geometry measurement report data must be entered in menu 7.

Sensor calibr. (menu 7.1)

In this menu various calibration data can be entered

Calibr. choice (menu 7.1.1)

The switching between WET and AUTO has a big influence on the calibration and the calculation of the flow value.

If WET is selected, the calibration parameters for SONO 3100 and SONO 3300 are taken from the factory calibration process. These parameters are stored in special WET calibration parameters.

If AUTO is selected, several sensor characteristics from the SONOKIT sensor geometry measurement report are combined and calculated to form the internal calibration factor. These calculated calibration factors for paths 1, 2, 3, and 4 are then read only parameters.

The calibration constants are based on the following SONOKIT sensor geometry measurement report data:

- Pipe diameter
- Length from transducer front to transducer front of every path
- Displacement of each sound path from center of pipe
- Average angle of every path
- Length of used cable in one sound path
- Roughness inside the pipe
- Viscosity of measured media

Note

Automatic calibration can only be used for ordinary round-shaped pipes.

Note

Always use **AUTO** calibration mode for flowmeter systems with **SONOKIT** sensors (menus 7.1.4.x.6 show the automatically calculated calibration factor).

Always use **WET** calibration mode for flowmeter systems with **SONO 3100** or **SONO 3300** sensors (menus 7.1.4.x.6 show the calibration factor, and menus 7.1.4.x.7 show the calculated flow).

App. param. (menu 7.1.2)

In this menu application-specific data can be entered.

Viscosity (menu 7.1.2.1)

The media viscosity value is used for the flow calculation and should only be changed for SONOKIT

The viscosity is default set to 0.01 cm²/s (normal water).

Correct. fact. (menu 7.1.2.2)

This is a parameter that can be used to adjust the calculated flow.

Fl. offset comp. (menu 7.1.2.3)

The flow offset compensation (a constant positive or negative flow) can be added to the measured flow for service purposes.

Cablelen. TOFKOR (menu 7.1.2.4)

The transmitter is always installed in a remote position. Therefore it is necessary to enter the length of the sensor cable in order to compensate for the time delay occurring in the cables.

The cable length is the total length of the signal cable in one sound path. The measuring unit of the cable length is meters. The tolerance is ±0.5 m.

Pipe diameter (menu 7.1.3.1)

This value represents the average inside diameter of the actual pipe and should only be changed for SONOKIT.

Note**Large sizes**

With nominal diameter settings above DN 2000 the device may not work properly.

Roughness (menu 7.1.3.2)

Roughness is the value for the inner pipe surface and should only be changed for SONOKIT.

The range of this value is 0.01 mm to 10.0 mm. The standard Siemens sensors have a roughness of approximately 0.4 mm.

Pipe material	Typical roughness
Smooth plastic pipe	0.1 mm
Polished stainless steel pipe	0.1 mm
Standard carbon steel pipe	0.4 mm

7.7 Sensor parameters (menu 7)

Pipe material	Typical roughness
Rusty carbon steel pipe	1 to 2 mm
Concrete pipe	2 to 5 mm

Tracks (menu 7.1.4)

This menu consists of the parameters for the path settings and should only be changed for SONOKIT. In the following table only the parameters for path 1 are explained. The parameters for paths 2, 3 and 4 are to be handled equally.

Length (menu 7.1.4.1.1)

In this menu the distance between the ultrasonic transducers (path length, L) can be read and should only be changed for SONOKIT. The value is required in order to calculate the ultrasonic velocity from the time of flight and is found in the SONOKIT sensor geometry measurement report.

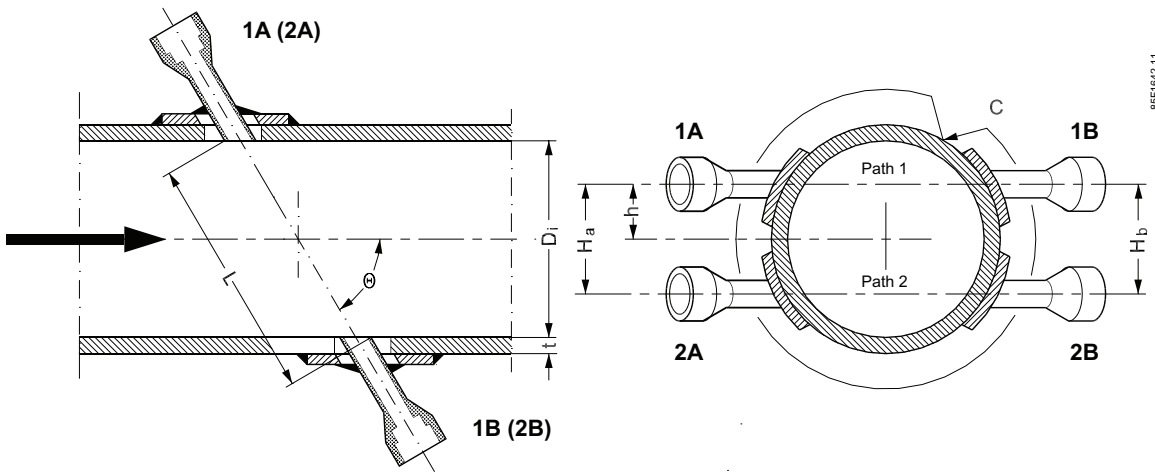

Figure 7-5 Sensor geometry data

Angle (menu 7.1.4.1.2)

In this menu the angle of each path (Θ in the figure above) can be read and should only be changed for SONOKIT.

Data for SONOKIT to be entered from the SONOKIT sensor geometry measurement report.

Displacement (menu 7.1.4.1.3)

In this menu the displacement for each path (h in the figure above) can be read and should only be changed for SONOKIT. "h" is the distance between the path and the center of the pipe.

Data for SONOKIT to be entered from the SONOKIT sensor geometry measurement report.

No. of tracks (menu 7.2)

In this menu the number of paths is set depending on the sensor design. The number of paths is preset from factory and can be changed to 1-path, 2-path, 3-path or 4-path. The number of paths should only be changed for SONOKIT.

Service and maintenance

8.1 Maintenance

The device is maintenance-free. However, a periodic inspection according to pertinent directives and regulations must be carried out.

An inspection can include, for example, check of:

- Ambient conditions
- Seal integrity of the process connections, cable entries, and cover
- Reliability of power supply, lightning protection, and grounds

 WARNING
--

Impermissible repair and maintenance of the device

- | |
|--|
| <ul style="list-style-type: none">• Repair and maintenance must be carried out by Siemens authorized personnel only. |
|--|

8.2 Return procedure

To return a product to Siemens, see AUTOHOTSPOT.

Contact your Siemens representative to clarify if a product is repairable, and how to return it. They can also help with quick repair processing, a repair cost estimate, or a repair report/cause of failure report.

NOTICE

Decontamination

The product may have to be decontaminated before it is returned. Your Siemens contact person will let you know for which products this is required.

See also

Decontamination declaration (<https://www.siemens.com/sc/declarationofdecontamination>)

Return goods delivery note (<https://www.siemens.com/processinstrumentation/returngoodsnote>)

8.3 Keying in sensor data

The following step-by-step procedure **only** applies to:

- FUS060 transmitters with SONOKIT sensors
- Replacement transmitters

NOTICE
SONO 3100 and SONO 3300
All FUS060 transmitters calibrated with sensors SONO 3100 or SONO 3300 are delivered with sensor data preset from factory. The data should not be changed

The step-by-step procedure describes the required parameters/data to be entered and the sequence of entering them in order to configure the transmitter correctly for a given pipe application.

Note

The pipe data are taken from the SONOKIT sensor geometry measurement report or from another sensor data sheet or calibration report.

Entering the data

1. Enter the sensor diameter (Di) (menu 7.1.3.1).

Note

If Di is smaller than registered, the setting in step 9 (displacement) must be changed first.

2. Choose appropriate engineering unit for flow (menu 3.1.1).
3. Enter maximum flow (menu 3.1.2).
4. Choose "AUTO" for calibration choice (menu 7.1.1).
5. Enter viscosity for media (menu 7.1.3.1), otherwise the default value (0.01 cm²/s for water 20 °C) will be used.
6. Enter inside roughness of the sensor pipe (menu 7.1.3.2), otherwise the default value (0.4 mm) will be used.
7. Enter the measured transducer distance for each path (menus 7.1.4.x.1).
8. Enter the measured angle for each path (menus 7.1.4.x.2).
9. Enter the measured displacement for each path (menu 7.1.4.x.3). Enter 0 for paths not used.
10. Check the number of paths (menu 7.2). They are preset from factory according to order.

11. Go to service menu and check for each path that:
 - control values for amplitude (menus 6.5.2.x) have a value within the interval 95 to 105.
 - control values for error counters (menus 6.5.4.x) are 0.
 - control values for TOF (menus 6.5.5.x) are stable and only vary in the nanosecond range (for example ± 10 ns).
12. Make sure that an absolute flowrate of zero is present and that the zero point adjustment procedure is activated via menu 6.6.3 Zero calibr..
13. Calculation of flow can be corrected by use of the customer correction factor (menu 7.1.2.2) which is a scaling factor.

Based on the entered data the transmitter is capable of measuring and calculating the actual flow. The accuracy of the system at this stage is dependent on for example the entered accuracy of the geometry data.

Diagnostics and troubleshooting

Only two general groups of errors are shown in the display: "Process error" and "Device error".

Device errors describe hardware errors, see Table 7-1 Error messages (Page 49).

Two main groups of process errors are:

- **Measuring path error**
 The medium in the measuring line is not permeable to sound; this applies both when the pipe is filled with gas or is empty. The measured value on the display is set to zero. Cable is broken or detached.
 The measured values have a very high dispersion so that errors in the measuring signal evaluation is indicated. It can be caused by disturbances in the flow pipe due to cavitation, twist or inhomogeneity such as bubbles or foreign bodies.
- **Flow measurement unreliable**
 The displayed measured values are not reliable and an "F" flashes in the right hand corner of the display.

Table 9-1 Error symptoms

Symptoms	Diagnostics	Cause	Remedy
Display shows no flow, and/or a flashing "F" is displayed continuously/occasionally	<ul style="list-style-type: none"> • Error "Measurement path error" is pending • Gain (menus 6.5.1.X) for the active paths > 250 • TOF (menus 6.5.5.X and 6.5.6.X) for the active paths is not stable • Error counters (menus 6.5.4.X) are not equal to 0. 	Pipe not filled with liquid	Make sure that the pipe is filled or at least the sound path is covered with liquid.
		Cable broken/detached	Make sure that the transducer cable is connected in the terminal housing of the transmitter. Make sure that the screen and center pin is connected inside the transducer top.
		Permanent disturbance inside the pipe	If possible, make sure that the transducer window inside the pipe is not damaged or that no permanent disturbance is present.

Symptoms	Diagnostics	Cause	Remedy
Flow not stable, and/or a flashing "F" is displayed continuously/occasionally	<ul style="list-style-type: none"> • Error "Measurement path error" is pending (menu 2.1) • Gain (menus 6.5.1.X) for the active paths > 250 • TOF (menus 6.5.5.X and 6.5.6.X) for the active paths is not stable • Error counters (menus 6.5.4.X) are not equal to 0. 	Air bubbles or particles of any kind disturbing the measurement	Make sure that the pipe line is ventilated and that the concentration of particles is limited to a level at which normal measurement with the meter is possible.
		Cable partly connected	<p>Make sure that the transducer cables are connected in the transmitter and in the sensors (SONO 3200 or SONO 3300).</p> <p>Check the connection of the cable screening.</p> <p>Make sure that the screen and center pin is connected inside the transducer top.</p>
		Ultrasonic echoes	Make sure that the entered path lengths correspond to the measurement report.
Device displays negative flow, and/or a flashing "F" is displayed continuously/occasionally	-	Transducer cables incorrectly connected	<p>Make sure that the transducer cables are connected correctly:</p> <p>1A → 1A 1B → 1B 2A → 2A 2B → 2B</p>
		Wrong setting of measurement direction	Make sure that the setting of menu 3.1.5.1 is "+ Direction"
Pulse/frequency output does not work, and/or a flashing "F" is displayed continuously/occasionally	Error "P/F too high" is pending (menu 2.1)	Internal electrical failure (open circuit, short circuit etc.)	Start simulation on the pulse/frequency output via menu 2.4. The frequency measuring instrument is coupled directly on the terminals.
		Pulse/pause or frequency out of range	Adjust pulse or frequency output settings (menu 4.2)
Device displays 0 flow. Device status: "OK"		Process flow value is very low compared with the low flow cut off limit of the device	For testing, check the low flow cut off (menu 3.1.6) is set to 0.
LCD display dark or partly dark (missing characters)		Internal electrical failure (open circuit, short circuit etc.)	Turn off power. Check the connections for the power supply PCBA and the flat cable for the display module. Start display test (menu 2.3.2.) in case of partly dark display.
Operation with infrared keys not possible		Light interference	<p>Check that display is not dirty.</p> <p>Check that display lid is locked (PDM force control).</p> <p>Bright auxiliary tools may be of assistance.</p>

9.1 Application information guide

In case the device needs service, the factory will typically request information about application and flowmeter.

Fill in this form and attach it to a Support request on:

Service and support (<http://www.siemens.com/automation/service&support>)

To: "Your local Siemens contact"	From: Company: E-mail: Phone no.: Fax no.:
--	---

Note

Sketch

It is recommended to prepare a diagram/sketch of the installation/application explaining inlet and outlet conditions; distance from pump; etc.

Table 9-2 Application data

Liquid	
• Chemical formula	
• Media name	
• Concentration	
• Density	
• Media viscosity at 20 °C (68 °F)	[mPa s]
• Media viscosity at process temperature	[mPa s]
Flow measurement range	
Nominal size	[m]
Process temperature	
Ambient temperature (transmitter)	
Process pressure	
Gas/solid content	
Explosion protection	

Table 9-3 Device data

Serial number	Menu 5.2.2	
Product type, Order number	Menu 5.2.1	
Software version	Menu 5.2.3	
Device status, error message, frequency, ...	Menu 2.1	
Flow	Menu 1.2	

Flow velocity	Menu 1.4	[m/s]
Sound velocity ($600 \leq c_{\text{Medium}} \leq 2000$)	Menu 1.5	[m/s]
Ultrasonic amplitude	Menu 1.6	[%]
Frequency	Menu 1.7	[Hz]
Current output	Menu 1.8	[mA]
Upper range for flow value	Menu 3.1.2	
Time constant	Menu 3.1.7	[s]
Low flow cut-off	Menu 3.1.6	[%]
Error signal	Menu 4.1.3	
Current limit	Menu 4.1.2	[mA]
Gain	Menu 6.5.1	
Trigger level	Menu 6.5.3	
Error count %	Menu 6.5.4	
Time of flight up (TOF up)	Menu 6.5.5	[ns]
Time of flight down (TOF down)	Menu 6.5.6	[ns]
Delta TOF	Menu 6.5.7	[ns]
Amplitude	Menu 6.5.2	

Technical specifications

10.1 SITRANS FUS060

Table 10-1 Input

Input	
Measurement	Flow by measuring the transit time difference of ultrasonic signals through ultrasonic transducers in DN 100 to 4000 2-path sensor pipes (optional, depending on selected size, 1-path or 4-path special solutions are possible)
Nominal diameters and number of paths	2-path DN 100 to DN 4000 (optionally also 1-path and 4-path, depending on size (DN 25 to DN 4000))
Max. cable length	120 m (395 ft) (shielded coaxial cable). For Ex version the transducer cable length is restricted to 3 m (9.84 ft) in order to meet requirements for electrical immunity. For 2-path and 4-path systems with sizes \geq DN 3000 cable length is restricted to 30 m (98.4 ft).

Note

Large sizes

With nominal diameter settings above DN 3000 the device may not work properly.

Table 10-2 Output

Output	
Analog output	
Signal range	4 to 20 mA active current output (13.2 V < open loop voltage < 15.8 V)
Upper limit	20 to 22.5 mA, adjustable
Signal on alarm	3.6 mA, 22 mA or 24 mA
Load	$\leq 600 \Omega$ for non Ex version $\leq 330 \Omega$ Ex version (HART $\geq 230 \Omega$)
Digital output 1 (pulse/frequency)	
Active or passive signal, can be configured with positive or negative logic	Active: 24 V DC, ≤ 24 mA, $R_i = 300 \Omega$ Passive: open collector, 30 V DC, ≤ 200 mA
For explosion protection	Passive: open collector, 30 V DC, ≤ 100 mA
Output function, configurable for:	Pulse output Adjustable pulse significance ≤ 5000 pulses/s Adjustable pulse width ≥ 0.1 ms
	Frequency output f_{END} selectable up to 10 kHz
Function	Pulse, frequency, limits, device status, flow direction

Output				
Configuration conditions				
Configuration	Supply	Load	Current	Output voltage limits (max./min)
Passive – Pos	12 V	75 Ω	160 mA	12 V / 600 mV
Passive – Neg	12 V	75 Ω	160 mA	12 V / 600 mV
Passive – Pos	12 V	520 Ω	23 mA	12 V / 100 mV
Passive – Neg	12 V	520 Ω	23 mA	12 V / 100 mV
Passive – Pos	12 V	6.1 kΩ	2 mA	12 V / 0 mV
Passive – Neg	12 V	6.1 kΩ	2 mA	12 V / 0 mV
Active – Pos	Internal (25 V)	1 kΩ	21 mA	21 V / -
Active – Neg	Internal (25 V)	1 kΩ	21 mA	21 V / -
Digital output 2 (relay)				
Relay, NC or NO contact	Switching capacity max. 5 W Max. 50 V DC, max. 200 mA (DC) Self-resetting fuse, Ri = 9 Ω			
For explosion protection	Max. 30 V DC, max. 100 mA (DC), max. 50 mA (AC); cf. ATEX approval certificate			
Output function, configurable for:	Alarm, flow direction, limits, no function			
HART communication via analog output (4 to 20 mA)	Via PC/laptop (PDM) or HART communicator			
Load	≥ 230 Ω			
Cable	2-wire shielded ≤ 3 km (≤ 1.86 miles) Multi-core shielded ≤ 1.5 km (≤ 0.93 miles)			
Protocol	HART, version 5.1			
Electrical isolation	Outputs electrically isolated from power supply and from each other (output isolation 63 V AC / 100 V DC to ground)			

Table 10-3 Accuracy

Accuracy *	
Pulse output	≤ ±0.5% of measured value at 0.5 to 9 m/s or ≤ ±0.25 / V [m/s] % of measured value at flow < 0.5 m/s
Analog output	As pulse output plus ±0.1% of measured value ±20 µA
Repeatability	≤ ±0.25% of measured value at 0.5 to 9 m/s
Reference conditions (water)	
Process temperature in the connected sensor	25 °C ±5 °C (77 °F ±9 °F)
Ambient temperature at the transmitter	25 °C ±5 °C (77 °F ±9 °F)

Accuracy *	
Installation conditions of connected sensor	Upstream section > 10 x DN and downstream section > 5 x DN
Transmitter warming-up time	30 minutes

* Typically depending on accuracy of installation measurement

Table 10-4 Rated operation conditions

Rated operation conditions	
Ambient conditions	
Ambient temperature	
Operation	-20 to +50 °C (-4 to +122 °F)
In potentially explosive atmospheres	Observe temperature classes
Storage	-25 to +80 °C (-13 to +176 °F)
Enclosure rating	IP65 / NEMA 4
Electromagnetic compatibility	
Emission	EN 55011/CISPR-11
Immunity	EN 61326-1 (Industry); use of shielded output cables is recommended
Medium conditions	
The measuring media must be ultrasonic signal compatible. It must be homogeneous and not two-phased to transfer the acoustic ultrasonic signals	
Process temperature	-200 to +250 °C (-328 to +482 °F) (not directly influenced by medium temperature)
Gases/solids	Influence accuracy of measurement (approx. max. 3 % gases or solids)

Table 10-5 Design

Design	
Transmitter (only as remote version)	Transmitter is connected to the transducers via 3 to 120 m (9.8 to 395 ft) long specially shielded cables (coaxial cable). For ATEX versions mounted in the Ex area only with 3 m (9.8 ft) long cables
Enclosure material	Die-cast aluminum, painted
Wall mounting bracket (standard and special)	Stainless steel (standard: always incl.)
Weight	4.4 kg (9.7 lb)
Cable glands	Power supply and outputs: 2 x M20 or 2 x 1/2" NPT Transducers/sensor: 2/4 x M16 or 2/4 x 1/2" NPT

Technical specifications

10.1 SITRANS FUS060

Table 10-6 Display and controls

Display and controls	
Display	LCD, two lines with 16 characters each (backlight)
Multi-display: 2 freely-selectable values Are displayed simultaneously in two lines	Volume flow, mass flow, volume, mass, flow velocity, sound velocity, ultrasonic signal information, current, frequency, alarm information
Operation	4 infrared keys, hierarchical menu shown with codes

Table 10-7 Power supply

Power supply	
Supply voltage	
Standard version	120 to 230 V AC \pm 15% (50/60 Hz) or 19 to 30 V DC/ 21 to 26 V AC
Ex version	19 to 30 V DC/ 21 to 26 V AC
Power failure	No effect for at least 1 period (> 20 ms)
Power consumption	Approx. 10 VA / 10 W

Table 10-8 Cable options

Cable options	
M20 cable gland set for FUS060 (M20) power and output connection, gray PA plastic, 2 pcs.	
Order number	C75196-Z1147-A18
Cable cross section	6 ... 12 mm (0.24" ... 0.47")
Ambient temperature	-40 ... +100 °C (-40 ... +212 °F)
Nominal torque	4.5 Nm
FUS060 ATEX version power and output connection, PA and brass, 1 x in blue (ATEX Ex i) and 1 x gray (ATEX Ex-e)	
Order number	C75196-Z1147-A5 A5E49854397
Cable cross section	5 ... 9 mm (0.20" ... 0.35")
Ambient temperature	-20 ... +95 °C (-4 ... +203 °F)
Nominal torque Brass	8 Nm
Nominal torque PA	4.5 Nm
1/2" NPT cable gland set for FUS060 (NPT) power and output connection, gray PA plastic, 2 pcs.	
Order number	C75196-Z1147-A16
Cable cross section	6 ... 12 mm (0.24" ... 0.47")
Ambient temperature	-40 ... +100 °C (-40 ... +212 °F)
Nominal torque	4.5 Nm
M25 cable gland set for the FUS060 PA (M25) power and output connection, gray PA plastic, 2 pcs.	
Order number	085U3332
Cable cross section	9 ... 16 mm (0.35" ... 0.63")
Ambient temperature	-40 ... +100 °C (-40 ... +212 °F)
Nominal torque	4 Nm

Cable options	
M16 x 1.5 cable gland set for FUS060 (M16) sensor connection, gray PA plastic, 2 pcs. and 2 pcs. blind	
Order number	A5E02436145
Cable cross section	5 ... 9 mm (0.20" ... 0.35")
Ambient temperature	-40 ... +100 °C (-40 ... +212 °F)
Nominal torque	3 Nm
M16 x 1.5 cable gland set for FUS060 (M16) sensor connection, brass chrome, 2 pcs. and 2 pcs. blind	
Order number	C75196-Z1147-A6
Cable cross section	5 ... 9 mm (0.20" ... 0.35")
Ambient temperature	-20 ... +105 °C (-4 ... +221 °F)
Nominal torque	5 Nm
½" NPT cable gland set for FUS060 (NPT) sensor connection, 4 pcs. M16 bush to ½" NPT and 4 pcs. ½" NPT gray PA plastic glands	
Order number	A5E00853663
Cable cross section	5 ... 9 mm (0.20" ... 0.35")
Ambient temperature	-20 ... +100 °C (-4 ... +212 °F)
Nominal torque	3.5 Nm

Table 10-9 Certificates and approvals

Certificates and approvals	
Explosion protection	ATEX II 2G Ex db eb mb [ia Ga] IIC T6...T3 Gb

Dimension drawings

11.1 Dimensional drawings

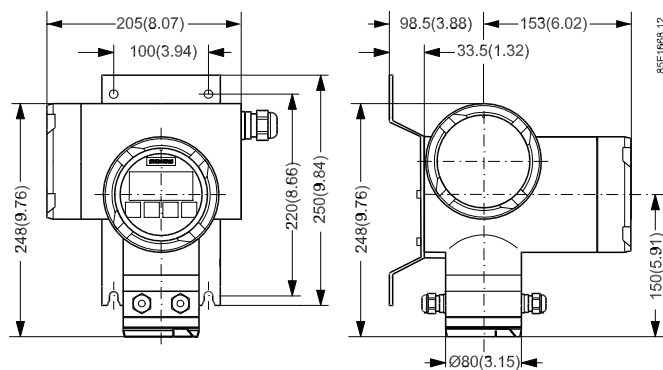

Figure 11-1 *FUS060 with standard mounting bracket.*

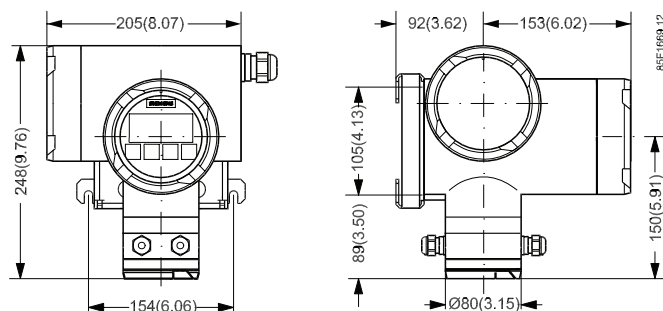

Figure 11-2 *FUS060 with the optional special mounting bracket.*

Product documentation and support

A.1 Product documentation

Process instrumentation product documentation is available in the following formats:

- Certificates (<http://www.siemens.com/processinstrumentation/certificates>)
- Downloads (firmware, EDDs, software) (<http://www.siemens.com/processinstrumentation/downloads>)
- Catalog and catalog sheets (<http://www.siemens.com/processinstrumentation/catalogs>)
- Manuals (<http://www.siemens.com/processinstrumentation/documentation>)
You have the option to show, open, save, or configure the manual.
 - "Display": Open the manual in HTML5 format
 - "Configure": Register and configure the documentation specific to your plant
 - "Download": Open or save the manual in PDF format
 - "Download as html5, only PC": Open or save the manual in the HTML5 view on your PC

You can also find manuals with the Mobile app at Industry Online Support (<https://support.industry.siemens.com/cs/ww/en/sc/2067>). Download the app to your mobile device and scan the device QR code.

Product documentation by serial number

Using the PIA Life Cycle Portal, you can access the serial number-specific product information including technical specifications, spare parts, calibration data, or factory certificates.

Entering a serial number

1. Open the PIA Life Cycle Portal (<https://www.pia-portal.automation.siemens.com>).
2. Select the desired language.
3. Enter the serial number of your device. The product documentation relevant for your device is displayed and can be downloaded.

To display factory certificates, if available, log in to the PIA Life Cycle Portal using your login or register.

Scanning a QR code

1. Scan the QR code on your device with a mobile device.
2. Click "PIA Portal".

To display factory certificates, if available, log in to the PIA Life Cycle Portal using your login or register.

A.2 Technical support

Technical support

If this documentation does not completely answer your technical questions, you can enter a Support Request (<http://www.siemens.com/automation/support-request>).

For help creating a support request, view this video here.

Additional information on our technical support can be found at Technical Support (<http://www.siemens.com/automation/csi/service>).

Service & support on the Internet

In addition to our technical support, Siemens offers comprehensive online services at Service & Support (<http://www.siemens.com/automation/service&support>).

Contact

If you have further questions about the device, contact your local Siemens representative at Personal Contact (<http://www.automation.siemens.com/partner>).

To find the contact for your product, go to "all products and branches" and select "Products & Services > Industrial automation > Process instrumentation".

Contact address for business unit:

Siemens AG
Digital Industries
Process Automation
Östliche Rheinbrückenstr. 50
76187 Karlsruhe, Germany

HART communication

B.1 Universal commands

The device supports the following universal commands:

Table B-1 Universal commands

Command number	Function	Parameters	Read / Write / Command
0	Read Unique Identifier	254, manufacturer_id, device_type, request_preambles, universal_revision, transmitter_revision, software_revision, hardware_revision <0xf8>, physical_signaling_code <0x07>, device_flags, device_id	Read
1	Read Primary Variable	PV.DIGITAL_UNITS, PV.DIGITAL_VALUE	Read
2	Read Loop Current And Percent Of Range	PV.ANALOG_VALUE, PV.PERCENT_RANGE	Read
3	Read Dynamic Variables And Loop Current	PV.ANALOG_VALUE, PV.DIGITAL_UNITS, PV.DIGITAL_VALUE, SV.DIGITAL_UNITS, SV.DIGITAL_VALUE, TV.DIGITAL_UNITS, TV.DIGITAL_VALUE	Read
6	Write Polling Address	polling_address	Write
11	Read Unique Identifier Associated With Tag	254, manufacturer_id, device_type, request_preambles, universal_revision, transmitter_revision, software_revision, hardware_revision <0xf8>, physical_signaling_code <0x07>, device_flags, device_id	Read
12	Read Message	message	Read
13	Read Tag, Descriptor, Date	tag, descriptor, date	Read

B.2 Common practice commands

Command number	Function	Parameters	Read / Write / Command
14	Read Primary Variable Transducer Information	PV.SENSOR_SERIAL_NUMBER, PV.SENSOR_UNITS, PV.UPPER_SENSOR_LIMIT, PV.LOWER_SENSOR_LIMIT, PV.MINIMUM_SPAN	Read
15	Read Device Information	func1_AI_lin_type, PV.RANGE_UNITS, PV.UPPER_RANGE_VALUE, PV.LOWER_RANGE_VALUE, PV.DAMPING_VALUE, write_protect, private_label_distributor	Read
16	Read Final Assembly Number	final_assembly_number	Read
17	Write Message	message	Write
18	Write Tag, Descriptor, Date	tag, descriptor, date	Write
19	Write Final Assembly Number	final_assembly_number	Write
38	Reset Configuration Changed Flag		Command
48	Read Additional Device Status	xmtr_specific_status_0, xmtr_specific_status_1	Read

B.2 Common practice commands

The device supports the following common practice commands:

Table B-2 Common practice commands

Command number	Function	Parameters	Read / Write / Command
34	Write Primary Variable Damping Value	PV.DAMPING_VALUE	Write
35	Write Primary Variable Range Values	PV.RANGE_UNITS (INFO), PV.UPPER_RANGE_VALUE, PV.LOWER_RANGE_VALUE	Write
40	Enter/Exit Fixed Current Mode	PV.ANALOG_VALUE	Command
41	Perform Transmitter Self Test		Command
42	Perform Device Reset		Command
43	Set Primary Variable Zero		Command
44	Write Primary Variable Units	PV.DIGITAL_UNITS	Write
45	Trim Primary Variable Current DAC Zero	PV.ANALOG_VALUE	Command
46	Trim Primary Variable Current DAC Gain	PV.ANALOG_VALUE	Command

Command number	Function	Parameters	Read / Write / Command
50	Read Dynamic Variable Assignments	primary_variable_code, secondary_variable_code, tertiary_variable_cod	Read
51	Write Dynamic Variable Assignments	primary_variable_code, secondary_variable_code, tertiary_variable_code	Write
53	Write Device Variables Units	transmitter_variable_code(INFO,INDEX), transmitter_variables[transmitter_variable_code].DIGITAL_UNITS	Write
59	Write Number Of Response Preambles	response_preambles	Write
108	Write Burst Command Number	burst_command_number	Write
109	Burst Mode Control	burst_mode_select	Write
110	Read All Dynamic Variables	PV.DIGITAL_UNITS, PV.DIGITAL_VALUE, SV.DIGITAL_UNITS, SV.DIGITAL_VALUE, TV.DIGITAL_UNITS, TV.DIGITAL_VALUE	Read

B.3 Device-specific commands

The device supports the following device-specific commands:

Table B-3 Device-specific commands

Command number	Function	Parameter	Read / Write / Command
128	Read HART Static Data Material	usd_accuracy_class, usd_wall_thickness_meas, usd_pressure_range, usd_flow_flange_type, usd_flow_flange_material, usd_seal_material, usd_power_supply, usd_cable_inlet, usd_ex_proof, phys_flow_meter_installation, usd_local_keys_mode_control_codes, phys_hart_communications_config, trans1_digital_input_state	Read
129	Write HART Static Data Material	usd_accuracy_class, usd_wall_thickness_meas, usd_pressure_range, usd_flow_flange_type, usd_flow_flange_material, usd_seal_material, usd_power_supply, usd_cable_inlet, usd_ex_proof, phys_flow_meter_installation, usd_local_keys_mode_control_codes	Write
130	Read HART Dynamic Variables	func6_TOT_total_value, func7_TOT_total_value, func3_TOT_total_value	Read
131	Execute HART Test 2		Command
132	Read HART Simulation	trans1_sim_flow_value trans1_sim_flow_mode	Read
133	Write HART Simulation	trans1_sim_flow_value, trans1_sim_flow_mode	Write
134	Execute HART Test 3		Command
135	Write HART Phys Dout1 Test	phys_dout1_test	Write
136	Write HART Phys Dout2 Test	phys_dout2_test	Write

Command number	Function	Parameter	Read / Write / Command
137	Read HART Operational Parameters	trans1_creep_quantity, trans1_flow_direction, trans1_measurement_mode, trans1_base_density, fus_integration_time, trans1_flow_lower_limit, trans1_flow_upper_limit	Read
138	Write HART Operational Parameters	trans1_creep_quantity, trans1_flow_direction, trans1_measurement_mode, trans1_base_density, fus_integration_time, trans1_flow_lower_limit, trans1_flow_upper_limit	Write
139	Read HART Totalizer Setting	func6_TOT_f_hart_set_tot, func7_TOT_r_hart_set_tot, func3_TOT_n_hart_set_tot, funcX_TOT_hart_set_tot_all	Read
140	Write HART Totalizer Setting	func6_TOT_f_hart_set_tot, func7_TOT_r_hart_set_tot, func3_TOT_n_hart_set_tot, funcX_TOT_hart_set_tot_all	Write
141	Read HART Flow Units	func1_AI_flow_hart_unit, trans1_hart_density_unit, func6_TOT_hart_unit_tot, func7_TOT_hart_unit_tot, func3_TOT_hart_unit_tot	read
142	Write HART Flow Units	trans1_hart_density_unit, func6_TOT_hart_unit_tot, func7_TOT_hart_unit_tot, func3_TOT_hart_unit_tot	Write
143	Read HART Analog Parameters	func1_AI_flow_hart_ana- log_alarm_select, func1_AI_flow_hart_upper_ana- log_limit	Read
144	Write HART Analog Parameters	func1_AI_flow_hart_ana- log_alarm_select, func1_AI_flow_hart_upper_ana- log_limit	Write
145	Read HART Dout1 Parameters	phys_dout1_select, phys_hart_dout1_mode, phys_dout1_pulse_width, phys_dout1_pulse_valency, phys_pulse_valency_hart_unit, phys_dout1_upper_frequency, phys_dout1_frequency_val	Read

B.3 Device-specific commands

Command number	Function	Parameter	Read / Write / Command
146	Write HART Dout1 Parameters	phys_dout1_select, phys_hart_dout1_mode, phys_dout1_pulse_width, phys_dout1_pulse_valency, phys_pulse_valency_hart_unit, phys_dout1_upper_frequency, phys_dout1_frequency_val	Write
147	Read HART Dout2 Parameters	phys_dout2_select, phys_dout2_mode, trans1_flow_dir_hysteresis	Read
148	Write HART Dout2 Parameters	phys_dout2_select, phys_dout2_mode, trans1_flow_dir_hysteresis	Write
149	Read HART Func1 Limits	func1_AI_hi_hi_lim, func1_AI_lo_lo_lim, func1_AI_hart_alarm_hys	Read
153	Read TOF Diff Tolerance	TOF_Diff_Tolerance, phys_pulse_length, Num_FirePulses, sensor_delval_choice, RLZD_1, RLZD_2, RLZD_3, RLZD_4	Read
154	Write TOF Diff Tolerance	TOF_Diff_Tolerance, phys_pulse_length, Num_FirePulses, sensor_delval_choice	Write
160	Write HART Func1 Limits	func1_AI_hi_hi_lim, func1_AI_lo_lo_lim, func1_AI_hart_alarm_hys	Write
161	Read HART Func2 Limits	func2_AI_hi_hi_lim, func2_AI_lo_lo_lim, func2_AI_hart_alarm_hys	Read
162	Write HART Func2 Limits	func2_AI_hi_hi_lim, func2_AI_lo_lo_lim, func2_AI_hart_alarm_hys	Write
163	Read HART Display Parameters	phys_hart_display1_select, phys_hart_display2_select, phys_flow_local_display, phys_language_local_display, phys_background_ilum_local_display, status_display	Read

Command number	Function	Parameter	Read / Write / Command
164	Write HART Display Parameters	phys_hart_display1_select, phys_hart_display2_select, phys_flow_local_display, phys_language_local_display, phys_background_ilum_local_display, status_display	Write
165	Write HART Passwords	phys_service_code_enter	Write
166	Read HART Phys Service Code Confirmation	phys_service_code_confirmation	Read
167	Read HART Sensor Application Parameter	trans1_calibration_factor, trans1_flowOffsetCompensation, sensor_pipeDiameter, sensor_roughness, sensor_calibrationChoice, sensor_viscosity	Read
168	Write HART Sensor Application Parameter	trans1_calibration_factor, trans1_flowOffsetCompensation, sensor_pipeDiameter, sensor_roughness, sensor_calibrationChoice, sensor_viscosity	Write
169	Read HART Sensor Application Parameter FACTORY	phys_TOFKORR, sensor_MUX_TableSelect, phys_trim_us_amplitude, trans1_flowCalculation_fTime	Read
170	Write HART Sensor Application Parameter FACTORY	phys_TOFKORR, sensor_MUX_TableSelect, phys_trim_us_amplitude, trans1_flowCalculation_fTime	Write
171	Read HART Trans1 Zero Point Adjust	trans1_zero_point_adjust	Read
172	Write HART Trans1 Zero Point Adjust	trans1_zero_point_adjust	Write
173	Read HART Range Values	func1_AI_pv_upper_range_value, func2_AI_pv_upper_range_value, func5_AI_pv_upper_range_value, func1_AI_pv_lower_range_value, func2_AI_pv_lower_range_value, func5_AI_pv_lower_range_value	Read
174	Write HART Range Values	func1_AI_pv_upper_range_value, func2_AI_pv_upper_range_value, func5_AI_pv_upper_range_value, func1_AI_pv_lower_range_value, func2_AI_pv_lower_range_value, func5_AI_pv_lower_range_value	Write
175	Read HART Damping Values	func1_AI_pv_ftime, func2_AI_pv_ftime, func5_AI_pv_ftime	Read
176	Write HART Damping Values	func1_AI_pv_ftime, func2_AI_pv_ftime, func5_AI_pv_ftime	Write

B.3 Device-specific commands

Command number	Function	Parameter	Read / Write / Command
177	Read HART Phys Device Ser Num	phys_device_ser_num	Read
178	Read HART Limit Totalizer F R	func6_TOT_hi_hi_lim, func6_TOT_lo_lo_lim, func6_TOT_alarm_hys, func7_TOT_hi_hi_lim, func7_TOT_lo_lo_lim, func7_TOT_alarm_hys	Read
179	Write HART Limit Totalizer F R	func6_TOT_hi_hi_lim, func6_TOT_lo_lo_lim, func6_TOT_alarm_hys, func7_TOT_hi_hi_lim, func7_TOT_lo_lo_lim, func7_TOT_alarm_hys	Write
180	Read HART Limit Totalizer N	func3_TOT_lo_lo_lim, func3_TOT_hi_hi_lim, func3_TOT_alarm_hys	Read
181	Write HART Limit Totalizer N	func3_TOT_lo_lo_lim, func3_TOT_hi_hi_lim, func3_TOT_alarm_hys	Write
182	Read HART Limit Func5	func5_AI_hi_hi_lim, func5_AI_lo_lo_lim, func5_AI_hart_alarm_hys	Read
183	Write HART Limit Func5	func5_AI_hi_hi_lim, func5_AI_lo_lo_lim, func5_AI_hart_alarm_hys	Write
184	Read HART Filter Errors	trans1_error_filter_uncertain, trans1_error_filter_bad	Read
185	Write HART Filter Errors	trans1_error_filter_uncertain, trans1_error_filter_bad	Write
186	Write HART Phys Code 1 Order	phys_code_1_order	Write
187	Read HART Trigger Constants Up	phys_trig_const1_1_up, phys_trig_const1_2_up, phys_trig_const1_3_up, phys_trig_const1_4_up	Read
188	Write HART Trigger Constants Up	phys_trig_const1_1_up, phys_trig_const1_2_up, phys_trig_const1_3_up, phys_trig_const1_4_up	Write
189	Read HART Trigger Constants Down	phys_trig_const1_1_dw, phys_trig_const1_2_dw, phys_trig_const1_3_dw, phys_trig_const1_4_dw	Read
190	Write HART Trigger Constants Down	phys_trig_const1_1_dw, phys_trig_const1_2_dw, phys_trig_const1_3_dw, phys_trig_const1_4_dw	Write

Command number	Function	Parameter	Read / Write / Command
191	Read HART WET Flow Constants	sensor_track1_WETFlowConstant, sensor_track2_WETFlowConstant, sensor_track3_WETFlowConstant, sensor_track4_WETFlowConstant	Read
192	Write HART WET Flow Constants	sensor_track1_WETFlowConstant, sensor_track2_WETFlowConstant, sensor_track3_WETFlowConstant, sensor_track4_WETFlowConstant	Write
193	Read HART AUTO Flow Constants	sensor_track1_flowConstant, sensor_track2_flowConstant, sensor_track3_flowConstant, sensor_track4_flowConstant	Read
194	Read HART WET Flows	sensor_track1_WetFlow, sensor_track2_WetFlow, sensor_track3_WetFlow, sensor_track4_WetFlow	Read
195	Read HART Track1 Layout	sensor_track1_length, sensor_track1_angle, sensor_track1_displacement	Read
196	Write HART Track1 Layout	sensor_track1_length, sensor_track1_angle, sensor_track1_displacement	Write
197	Read HART Track2 Layout	sensor_track2_length, sensor_track2_angle, sensor_track2_displacement	Read
198	Write HART Track2 Layout	sensor_track2_length, sensor_track2_angle, sensor_track2_displacement	Write
199	Read HART Track3 Layout	sensor_track3_length, sensor_track3_angle, sensor_track3_displacement	Read
200	Write HART Track3 Layout	sensor_track3_length, sensor_track3_angle, sensor_track3_displacement	Write
201	Read HART Track4 Layout	sensor_track4_length, sensor_track4_angle, sensor_track4_displacement	Read
202	Write HART Track4 Layout	sensor_track4_length, sensor_track4_angle, sensor_track4_displacement	Write

Command number	Function	Parameter	Read / Write / Command
205	Read HART Debug Values Track1	phys_debug_gain_up_1, phys_debug_gain_dw_1, phys_debug_level_up_1, phys_debug_level_dw_1, phys_debug_trigger_up_1, phys_debug_trigger_dw_1, phys_debug_rm_tdc_tof_up_1, phys_de- bug_rm_tdc_tof_down_1, phys_debug_delta_tof_1, phys_debug_meas_error_per- cent_1	Read
206	Read HART Debug Values Track2	phys_debug_gain_up_2, phys_debug_gain_dw_2, phys_debug_level_up_2, phys_debug_level_dw_2, phys_debug_trigger_up_2, phys_debug_trigger_dw_2, phys_debug_rm_tdc_tof_up_2, phys_de- bug_rm_tdc_tof_down_2, phys_debug_delta_tof_2, phys_debug_meas_error_per- cent_2	Read
207	Read HART Debug Values Track3	phys_debug_gain_up_3, phys_debug_gain_dw_3, phys_debug_level_up_3, phys_debug_level_dw_3, phys_debug_trigger_up_3, phys_debug_trigger_dw_3, phys_debug_rm_tdc_tof_up_3, phys_de- bug_rm_tdc_tof_down_3, phys_debug_delta_tof_3, phys_debug_meas_error_per- cent_3	Read
208	Read HART Debug Values Track4	phys_debug_gain_up_4, phys_debug_gain_dw_4, phys_debug_level_up_4, phys_debug_level_dw_4, phys_debug_trigger_up_4, phys_debug_trigger_dw_4, phys_debug_rm_tdc_tof_up_4, phys_de- bug_rm_tdc_tof_down_4, phys_debug_delta_tof_4, phys_debug_meas_error_per- cent_4	Read
209	Read HART Zero Points	trans1_zero_TDC_RLZD_1, trans1_zero_TDC_RLZD_2, trans1_zero_TDC_RLZD_3, trans1_zero_TDC_RLZD_4	Read

Command number	Function	Parameter	Read / Write / Command
210	Write HART Zero Points	trans1_zero_TDC_RLZD_1, trans1_zero_TDC_RLZD_2, trans1_zero_TDC_RLZD_3, trans1_zero_TDC_RLZD_4	Write
211	Read HART Deviations	trans1_std_deviation_TDC_RLZD_1, trans1_std_deviation_TDC_RLZD_2, trans1_std_deviation_TDC_RLZD_3, trans1_std_deviation_TDC_RLZD_4	Read
212	Execute HART Undo Zero Trim		Command
213	Read HART Track Setting	sensor_NumberOfTracks	Read
214	Write HART Track Setting	sensor_NumberOfTracks	Write
215	Read HART Trigger Setting	phys_trig_control, phys_trig_status, phys_trig_suggest, deviate_error_number	Read
216	Read HART Set Trigger Search US Channel	set_TriggerSearch_USChannel	Read
217	Write HART Set Trigger Search US Channel	set_TriggerSearch_USChannel	Write
218	Write HART Trigger Setting	phys_trig_control	Write
219	Read HART Software Parameters	ShotShotWaitTimeT1, ShotShotWaitTimeT2, ShotShotWaitTimeT3, ShotShotWaitTimeT4, ShotPairLoop2CountT1, ShotPairLoop2CountT2, ShotPairLoop2CountT3, ShotPairLoop2CountT4, ShotPairWaitTimeT1, ShotPairWaitTimeT2, ShotPairWaitTimeT3, ShotPairWaitTimeT4, LoopCount3Normal, LoopWaitTime3N, AfterLoopWait3N, LoopCount3Reverse, LoopWaitTime3R, AfterLoopWait3R, LoopCount4, TxGainUpDownCombined	Read

B.3 Device-specific commands

Command number	Function	Parameter	Read / Write / Command
220	Write HART Software Parameters	ShotShotWaitTimeT1, ShotShotWaitTimeT2, ShotShotWaitTimeT3, ShotShotWaitTimeT4, ShotPairLoop2CountT1, ShotPairLoop2CountT2, ShotPairLoop2CountT3, ShotPairLoop2CountT4, ShotPairWaitTimeT1, ShotPairWaitTimeT2, ShotPairWaitTimeT3, ShotPairWaitTimeT4, LoopCount3Normal, LoopWaitTime3N, AfterLoopWait3N, LoopCount3Reverse, LoopWaitTime3R, AfterLoopWait3R, LoopCount4, TxGainUpDownCombined	Write
221	Read HART Factory Test	device_date_copy, DAC_TestSelect, DAC_GainValue, DAC_TriggerValue, tdc_up_down_mode	Read
222	Write HART Factory Test	device_date_copy, DAC_TestSelect, DAC_GainValue, DAC_TriggerValue, tdc_up_down_mode	Write
223	Read HART Manufacturer Data	usd_device_date, phys_software_rev	Read
224	Write HART Manufacturer Data	usd_device_date, device_id	Write
225	Write HART Index Flow Trim	IndexFlowTrim	Write
226	Read HART Flow Trim	FlowTrimValueX, FlowTrimValueY	Read
227	Write HART Flow Trim	FlowTrimValueX, FlowTrimValueY	Write
228	Read HART Analog Output Trim	DAC_4, DAC_12, DAC_20	Read
229	Write HART Analog Output Trim	DAC_4, DAC_12, DAC_20	Write
230	Read HART Eeprom Setting	usd_eeprom_version, eeprom_reset	Read
231	Write HART Eeprom Version	usd_eeprom_version	Write
232	Write HART Eeprom Reset	eeprom_reset	Write

Command number	Function	Parameter	Read / Write / Command
233	Read HART Phys Hardware Rev	phys_hardware_rev	Read
234	Write HART Phys Hardware Rev	phys_hardware_rev	Write
235	Read HART Phys Model Num	phys_model_num	Read
236	Write HART Phys Model Num	phys_model_num	Write
237	Read HART Specialitäten	analog_out_select, Action_Progress_Cnt, usd_zero_trim_status, error_suppress	Read
238	Write HART Specialitäten	error_suppress, usd_anl_out_test	Write
239	Read HART Trigger Constants 1	phys_trig_const_1, phys_trig_const_2, phys_trig_const_3, phys_trig_const_4, phys_trig_const_5, phys_trig_const_6, phys_trig_const_7, phys_trig_const_8, phys_trig_const_9, phys_trig_const_10, phys_trig_const_11, phys_trig_const_12, phys_trig_const_13, phys_trig_const_14, phys_trig_const_15, phys_trig_const_16, phys_trig_const_17, phys_trig_const_18, phys_trig_const_19, phys_trig_const_20, phys_trig_const_21, phys_trig_const_22, phys_trig_const_23, phys_trig_const_24, phys_trig_const_25	Read

Command number	Function	Parameter	Read / Write / Command
240	Read HART Trigger Constants 2	phys_trig_const_26, phys_trig_const_27, phys_trig_const_28, phys_trig_const_29, phys_trig_const_30, phys_trig_const_31, phys_trig_const_32, phys_trig_const_33, phys_trig_const_34, phys_trig_const_35, phys_trig_const_36, phys_trig_const_37, phys_trig_const_38, phys_trig_const_39, phys_trig_const_40, phys_trig_const_41, phys_trig_const_42, phys_trig_const_43, phys_trig_const_44, phys_trig_const_45, phys_trig_const_46, phys_trig_const_47, phys_trig_const_48, phys_trig_const_49, phys_trig_const_50	Read
241	Read HART Trigger Constants 3	phys_trig_const_51, phys_trig_const_52, phys_trig_const_53, phys_trig_const_54, phys_trig_const_55, phys_trig_const_56, phys_trig_const_57, phys_trig_const_58, phys_trig_const_59, phys_trig_const_60, phys_trig_const_61, phys_trig_const_62, phys_trig_const_63, phys_trig_const_64, phys_trig_const_65, phys_trig_const_66, phys_trig_const_67, phys_trig_const_68, phys_trig_const_69, phys_trig_const_70, phys_trig_const_71, phys_trig_const_72, phys_trig_const_73, phys_trig_const_74, phys_trig_const_75	Read

Command number	Function	Parameter	Read / Write / Command
242	Read HART Trigger Constants 4	phys_trig_const_76, phys_trig_const_77, phys_trig_const_78, phys_trig_const_79, phys_trig_const_80, phys_trig_const_81, phys_trig_const_82, phys_trig_const_83, phys_trig_const_84, phys_trig_const_85, phys_trig_const_86, phys_trig_const_87, phys_trig_const_88, phys_trig_const_89, phys_trig_const_90, phys_trig_const_91, phys_trig_const_92, phys_trig_const_93, phys_trig_const_94, phys_trig_const_95, phys_trig_const_96, phys_trig_const_97, phys_trig_const_98, phys_trig_const_99, phys_trig_const_100	Read
243	Read HART Trigger Constants 5	phys_trig_const_101, hys_trig_const_102, phys_trig_const_103, phys_trig_const_104, phys_trig_const_105, phys_trig_const_106, phys_trig_const_107, phys_trig_const_108, phys_trig_const_109, phys_trig_const_110, phys_trig_const_111, phys_trig_const_112, phys_trig_const_113, phys_trig_const_114, phys_trig_const_115, phys_trig_const_116, phys_trig_const_117, phys_trig_const_118, phys_trig_const_119, phys_trig_const_120, phys_trig_const_121, phys_trig_const_122, phys_trig_const_123, phys_trig_const_124, phys_trig_const_125	Read

Command number	Function	Parameter	Read / Write / Command
244	Read HART Trigger Constants 6	phys_trig_const_126, phys_trig_const_127, phys_trig_const_128, phys_trig_const_129, phys_trig_const_130, phys_trig_const_131, phys_trig_const_132, phys_trig_const_133, phys_trig_const_134, phys_trig_const_135, phys_trig_const_136, phys_trig_const_137, phys_trig_const_138, phys_trig_const_139, phys_trig_const_140, phys_trig_const_141, phys_trig_const_142, phys_trig_const_143, phys_trig_const_144, phys_trig_const_145, phys_trig_const_146, phys_trig_const_147, phys_trig_const_148, phys_trig_const_149, phys_trig_const_150	Read
245	Read HART Trigger Constants 7	phys_trig_const_151, phys_trig_const_152, phys_trig_const_153, phys_trig_const_154, phys_trig_const_155, phys_trig_const_156, phys_trig_const_157, phys_trig_const_158, phys_trig_const_159, phys_trig_const_160, phys_trig_const_161, phys_trig_const_162, phys_trig_const_163, phys_trig_const_164, phys_trig_const_165, phys_trig_const_166, phys_trig_const_167, phys_trig_const_168, phys_trig_const_169, phys_trig_const_170, phys_trig_const_171, phys_trig_const_172, phys_trig_const_173, phys_trig_const_174, phys_trig_const_175	Read

Command number	Function	Parameter	Read / Write / Command
246	Read HART Trigger Constants 8	phys_trig_const_176, phys_trig_const_177, phys_trig_const_178, phys_trig_const_179, phys_trig_const_180, phys_trig_const_181, phys_trig_const_182	Read
247	Read HART Time Correction	phys_TOFKORR_CableLength	Read
248	Write HART Time Correction	phys_TOFKORR_CableLength	Write
249	Read HART Trans1 Flow Tube Diameter	trans1_flow_tube_diameter	Read
250	Write HART Trans1 Flow Tube Diameter	trans1_flow_tube_diameter	Write
251	Read HART Software Control	SWT_TrackNr, SWT_StateCnt_1up, SWT_StateCnt_1dw, SWT_StatusUp, SWT_StatusDw, SWT_Status, SWT_GoodCnt, SWT_BadCnt	Read
252	Write HART Software Control	SWT_TrackNr	Write
253	Read Log List	not used	Read

HMI menu structure



The graphic below only shows the main levels of the menu structure.

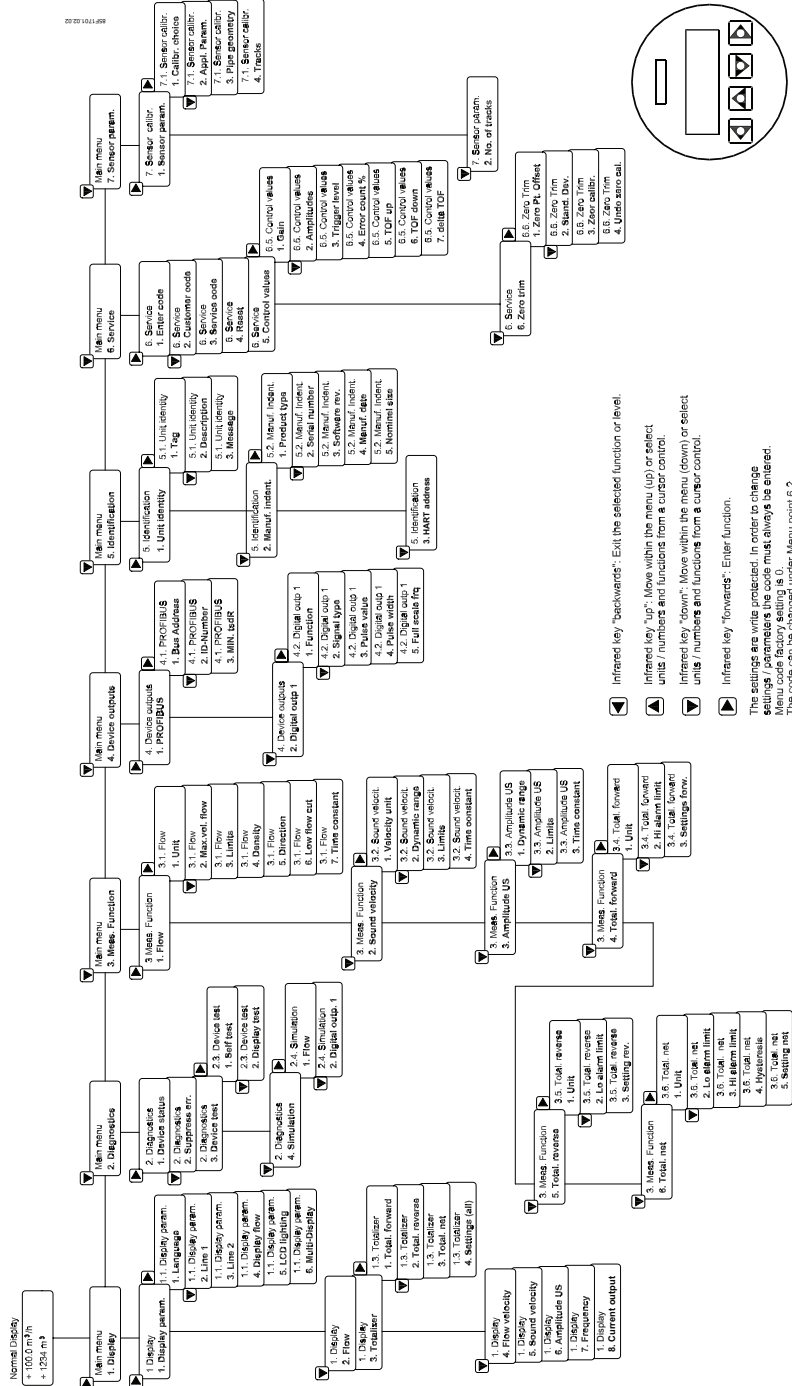

Figure C-1 Menu structure (main menus; FW 4.00.00-15)

Note

All menu items relevant for end users and simple service cases are listed in the following tables.

C.1 Menu items (FW Rev. 4.00.00-15)**C.1.1 Menu 1 - Display****Note**

Only menu items relevant for end users and simple service cases are listed in this table.

Menu code	Device function, Parameters	Description	Factory setting	Setting options	Read / Write
1.1	Display param.				
1.1.1	Language	Language in display	English	english deutsch français español	Write
1.1.2	Line 1	Parameter value in line 1	Flow	Flow Totalizer net Total. forward Total. reverse Flow Velocity Sound velocity US-Amplitude Analog Output Frequency	Write
1.1.3	Line 2	Parameter value in line 2	Total. net	Flow Totalizer net Total. forward Total. reverse Flow Velocity Sound velocity US-Amplitude Analog output Frequency	Write

Menu code	Device function, Parameters	Description	Factory setting	Setting options	Read / Write
1.1.4	Display Flow	Select presentation	Physical Unit	Physical Unit % Bar Diagramm	Write
1.1.5	LCD lighting	Switch LCD on/off (automatically set to Off at power-off)	Off	On (turns off automatically after 1 hour) Off (turns off automatically after 10 minutes)	Write
1.1.6	Multi-Display	Display of two measured values in lines 1 and 2	Line 1: Flow Line 2: Totalizer	See menu 1.1.2 See menu 1.1.3	Read
1.2	Flow				
1.2	Flow	Display of actual flow in metering tube (possible range -12 to +12 m/s)		See menu 3.1	Read
1.3	Totalizer				
1.3.1	Total. forward	Display of actual totalizer forward value		See menu 3.4	Read
1.3.2	Total. reverse	Display of actual totalizer reverse value		See menu 3.5	Read
1.3.3	Total. net	Display of actual totalizer difference value (Forward-reverse)		See menu 3.6	Read
1.3.4	Settings (all)	All totalizers will be set to zero. (Independent setting of totalizers in menu 3.4, 3.5, 3.6)	No action	No action Reset+Stop Reset+Start	Write
1.4	Flow velocity				
1.4	Flow velocity	Display of actual flow velocity (m/s) in metering tube			Read
1.5	Sound velocity				
1.5	Sound velocity	Display of actual sound velocity in medium (m/s or ft/s)		See menu 3.2	Read
1.6	Amplitude US				
1.6	Amplitude US	Display of actual relative ultrasonic amplitude (%) of received ultrasonic signals (reference water).		See menu 3.3	Read
1.7	Frequency				
1.7	Frequency	Display of actual frequency output value (Hz)		See menu 4.2.5	Read
1.8	Current Output				
1.8	Current Output	Display of actual current value of analogue output (mA)		See menu 4.1	Read

C.1.2 Menu 2 - Diagnostics

Menu code	Device function, Parameters	Description	Factory setting	Setting options	Read / Write
2.1	Device status				
2.1	Device status	Error messages are shown		Only read See table in chapter 6.2	Read
2.2	Suppress err.				
2.2	Suppress err.	(not stored) Switch off error message with effect on: Analog output Digital output 1 Digital output 2	None	None Unreliab. flow Meas path error Both	Write
2.3	Device test				
2.3.1	Self test	Test device status. If device finds no defect, reply is "OK"			Read
2.3.2	Display test	Visual LCD test. All display segments are activated (turn black)			Read
2.4	Simulation				
2.4.1	Flow	Simulation of flow.		-110 to + 110%	Write
	Value	Simulation value. Affects all outputs and totalizers *.	0%		
	Time	Duration of simulation. After expiration of this time the normal measuring mode is resumed.	End	End (no action) 10 min 30 min 60 min	
2.4.2	Digital outp 1	Simulation of output signal for digital output 1 with selected value	End	End (no simulation) 0.1 Hz 1 Hz 10 Hz 100 Hz 1 kHz 10 kHz Alarm on Alarm off	Write

Menu code	Device function, Parameters	Description	Factory setting	Setting options	Read / Write
2.4.3	Digital outp 2	Simulation of output signal for digital output 2 (relay) with selected value	End	End (no simulation) Relay on Relay off	Write
2.4.4	Analog output	Simulation of output current of analogue output with selected value	4 mA	4 mA 10 mA 12 mA 20 mA Error signal	Write

* Active errors will affect the output functions, see menus 2.1 and 2.2.

C.1.3 Menu 3 - Measuring functions

Menu code	Device function, Parameters	Description	Factory setting	Setting options	Read / Write
3.1	Flow				
3.1.1	Unit	Physical units for volume flow, mass flow Note: Whenever using mass flow, the actual density must be entered in menu 3.1.4	m ³ /h	l/s, l/min, l/h, m ³ /s, m ³ /h, m ³ /d, Ml/d, ft ³ /s, ft ³ /min, ft ³ /d, gal/s, gal/min, gal/d, Mgal/d, ImpGal/s, ImpGal/min, ImpGal/d, g/s, g/min, g/h, kg/s, kg/min, kg/d, Ton/min, Ton/h, Ton/d, lb/s, lb/min, lb/h, lb/d, STon/min, STon/h, STon/d	Write
3.1.2	Max. vol. flow	Full scale value Note: Corresponds to 20 mA value (menu 4.1) and selected "Full scale frq" (menu 4.2.5)	Depends on sensor size	See dimension table in sensor manual Setting range: 0.000075 ... Qmax m ³ /s $Q_{max} = \pi \times r^2 \times 12 \text{ m/s}$, r=pipe diameter/2 (pipe diameter defined in menu code 7.1.3.1.2)	Write
3.1.3	Limits	Flow unit according to menu 3.1.1			
3.1.3.1	Lo alarm limit	Lower alarm limit (< Hi alarm limit)	Depends on sensor size	See dimension table in sensor manual	Write
3.1.3.2	Hi alarm limit	Upper alarm limit (< Lo alarm limit)	Depends on sensor size	See dimension table in sensor manual	Write
3.1.3.3	Hysteresis	Hysteresis for limit in % of full scale value	1 %	0 % to 20 %	Write

Menu code	Device function, Parameters	Description	Factory setting	Setting options	Read / Write
3.1.4.	Density				
	Unit	Density unit	kg/m ³	g/cm ³ , g/l, kg/l, kg/m ³ , lb/ft ³ , lb/in ³ , lb/gal, lb/lmpgal	Write
	Density	Input of density value for arithmetic calculation of mass flow	+1000.00 kg/m ³	200 to 5000 kg/m ³	
3.1.5	Direction				
3.1.5.1	Flow direction	Determination of main direction of flow (forward direction)	+ Direction	+ Direction - Direction	Write
3.1.5.2	Mea. direction	Choice of measurement direction	Forward only	Forward only Forward + reverse	Write
3.1.5.3	Hysteresis	Setting hysteresis for flow direction related to full scale value	1 %	0 to 20 %	Write
3.1.6	Low flow cut	Determination of switching point for low flow cut-off. Suppression is related to full scale value	1 %	0 to 20 %	Write
3.1.7	Time constant				
	Time constant	Selection of time constants for flow measuring values	5.0 s	0.0 to 200 s (min 5.0 s recommended to optimize damping)	Write
3.2	Sound velocity				
3.2.1	Velocity unit	Unit for sound velocity	m/s	m/s ft/s	Write
3.2.2	Dynamic range				
3.2.2.1	Lower Value	Lower range value for sound velocity Lower range value (< Upper Value)	+600 m/s	+200 to 2000 m/s	Write
3.2.2.2	Upper Value	Upper range value for sound velocity Upper range value (> Lower Value)	+2000.00 m/s	+200 to 2000 m/s	Write
3.2.3	Limits				
3.2.3.1	Lo alarm limit	Lower alarm limit (< Hi alarm limit)	+200 m/s	200 to 2000 m/s	Write
3.2.3.2	High alarm limit	Upper alarm limit (> Lo alarm limit)	+2000 m/s	200 to 2000 m/s	Write
3.2.3.3	Hysteresis	Hysteresis for limit	5 %	0 to 20 %	Write
3.2.4	Time constant	Selection of time constant for sound velocity measuring values	5 s	0 to 200 s (min 5.0 s recommended to optimize damping)	Write
3.3	Amplitude US				
3.3.1	Dynamic range				
3.3.1.1	Lower Value	Lower range value for sound velocity Lower range value (< Upper Value)	1 %	1 to 150 %	Write
3.3.1.2	Upper Value	Upper range value for sound velocity Upper range value (> Lower Value)	100 %	1 to 150 %	Write
3.3.2	Limits				
3.3.2.1	Lo alarm limit	Lower alarm limit (< Hi alarm limit)	1 %	1 % to 150 %	Write
3.3.2.2	Hi alarm limit	Upper alarm limit (> Lo alarm limit)	120 %	1 % to 150 %	Write

Menu code	Device function, Parameters	Description	Factory setting	Setting options	Read / Write
3.3.2.3	Hysteresis	Hysteresis for limit	1 %	0 to 20 %	Write
3.3.3	Time constant	Filter time constant for amplitude US measuring values	+10.00 s	0 to 200 s (min 5.0 s recommended to optimize damping)	Write
3.4	Total. forward				
3.4.1	Unit	Physical volume unit or mass unit. Note: Whenever using mass flow the actual density must be entered in menu 3.1.4	m ³	l, hl, m ³ , MI, ft ³ , gal, Mgal, ImpGal, MImpGal, g, kg, Ton, lb	Write
3.4.2	Hi alarm limit	Value for upper limit of alarm	+1.000.000.000 m ³	0 to 1.000.000.000 m ³	Write
3.4.3	Settings forw.	Volume totalizer reset to "0" and "stop/start"	No action	No action Reset+Stop Reset+Start	Write
3.5	Total. reverse				
3.5.1	Unit	Physical volume unit or mass unit Note: Whenever using mass flow the actual density must be entered in menu 3.1.4	m ³	l, hl, m ³ , MI, ft ³ , gal, Mgal, ImpGal, MImpGal, g, kg, Ton, lb	Write
3.5.2	Lo alarm limit	Value for lower limit of alarm	-1.000.000.000	-1.000.000.000 to 0	Write
3.5.3	Settings rev.	Volume totalizer reset to "0" and "stop/start"	No action	No action Reset+Stop Reset+Start	Write
3.6	Total. net				
3.6.1	Unit	Physical volume unit or mass unit Note: Whenever using mass flow the actual density have to be selected in menu 3.1.4	m ³	l, hl, m ³ , MI, ft ³ , gal, Mgal, ImpGal, MImpGal, g, kg, Ton, lb	Write
3.6.2	Lo alarm limit	Lower alarm limit Lower alarm limit (< Hi alarm limit)	-1.000.000.000 m ³	-1.000.000.000 to 0 m ³	Write
3.6.3	Hi alarm limit	Upper alarm limit Upper alarm limit (> Lo alarm limit)	+1.000.000.000 m ³	-0 to 1.000.000.000 m ³	Write
3.6.4	Hysteresis	Hysteresis for the limits	0	0 to 3	Write
3.6.5	Settings net	Volume totalizer reset to "0" and "stop/start"	No action	No action Reset+Stop Reset+Start	Write

C.1.4 Menu 4 - Device outputs

Menu number	Device function, Parameters	Description	Factory setting	Setting options	Read / Write
4.	Device outputs				
4.1	Analog output				
4.1.1	Analog output	Assignment of a measured variable to output signal	Flow	Flow Sound velocity US-amplitude	Write
4.1.2	Current limit	Upper current limit	20.5 mA	20.0 to 22.5 mA	Write
4.1.3	Error Signal	Output current in case of error. Use of "hold" in Xs means current will be kept for X seconds	3.6 mA	3.6 mA 22.0 mA 24.0 mA Hold 5s Hold 20s Hold 40s Hold 60s Hold 120s Hold 240s Hold continuous	Write
4.1.4	Current output	Actual current of analog output in mA		See menus 4.1.1, 4.1.2 and 4.1.3	Read
4.1.5	Flow range %	Actual measurement in %		See menu 4.1.1	Read
4.2	Digital outp 1				
4.2.1	Function	Assignment of output function Note: Pulse and frequency are always displayed as absolute values (no negative values)	Pulse	Pulse Frequency Alarm Flow dir. forward Flow min Flow max Flow min/max Total. forw. max Total. rev. min Total. net. min Total. net max No function	Write
4.2.2	Signal type	Configure output: Signal: active or passive Logic: positive or negative	Passive-pos	Active-pos Active-neg Passive-pos Passive-neg	Write

Menu number	Device function, Parameters	Description	Factory setting	Setting options	Read / Write
4.2.3	Pulse value				
	Unit	Physical unit per impulse(only required if "Pulse" is used)	m ³ /Imp	l/Imp, m ³ /Imp, Gall/Imp, ImpGall/Imp, kg/Imp, TonImp, lb/Imp	Write
	Pulse rate	Number of volume units per impulse (only required if "Pulse" output function is used)	1 m ³ /Imp	0 to 1000.0	
4.2.4	Pulse width	Setting pulse width (only required if "Pulse" output function is used)	0.10 ms	0.1 to 2000 ms	Write
4.2.5	Full scale frq	Full scale frequency (only required if the "Frequency" output function is used) Note: Pulse and frequency are always displayed as absolute values (no negative values)	10000 Hz	2 to 10 000 Hz	Write
4.3	Digital outp 2				
4.3.1	Function	Assignment of output function	Alarm	Alarm Flow dir. forward Flow min/max Flow max Flow min min max US-vel max US-vel min US-vel min max US-ampl Max US-Ampl Min US-Ampl No function	Write
4.3.2	Signal type	Logic of signal output in case of function in menu 4.3.1	Contact opens	Contact closes Contact opens	Write

C.1.5 Menu 5 - Identification

Menu code	Device function, Parameters	Description	Factory setting	Setting options	Read / Write
5.1	Unit identity				
5.1.1	Tag	TAG number on metering unit		Max. 8 characters	Write
5.1.2	Description	TAG number description		Max. 16 characters	Write
5.1.3	Message	Message TAG		Max. 32 characters	Write
5.2	Manuf. Ident.				
5.2.1	Product type	Product type	Order number		Read

Menu code	Device function, Parameters	Description	Factory setting	Setting options	Read / Write
5.2.2	Serial number	Device serial number	Format: xxxxxxHwwy x = number ww = production week y = production year		Read
5.2.3	Software rev.	Software revision	4.00.00		Read
5.2.4	Manuf. date	Manufacturing date - DD.MM.YYYY			Read
5.2.5	Nominal size	Sensor size. Depends on diameter, only informal detail, no influence on measurements			Read
5.3	HART address	True identification in HART address	0	0 to 15	Read

C.1.6 Menu 6 - Service

Menu code	Device function, Parameters	Description	Factory setting	Setting options	Read / Write
6.1	Enter code	Entering the 4 digit code selected in menu 6.2 in order to change user parameters	0	In accordance with selection in menu 6.2	Write
6.2	Customer Code	Selection of a personal code. Code 0: User parameter are not protected. Code > 0: User parameters are protected.	0	0 or 1000 to 9999	Write
6.3	Service code	Only for service in the Siemens factory			Write
6.4	Reset	Re-start of device without change of parameters (warm restart)	Cancel	Cancel Reset	Write
6.5	Control values				
6.5.1	Gain				
6.5.1.1	Gain up 1	Gain of first path up 0 to 255; optimal: 40 to 100			Read
6.5.1.2	Gain dw 1	Gain of first path down 0 to 255; optimal: 40 to 100			Read
6.5.1.3	Gain up 2	Gain of second path up 0 to 255; optimal: 40 to 100			Read
6.5.1.4	Gain dw 2	Gain of second path down 0 to 255; optimal: 40 to 100			Read
6.5.1.5	Gain up 3	Gain of third path up 0 to 255; optimal: 40 to 100			Read
6.5.1.6	Gain dw 3	Gain of third path down 0 to 255; optimal: 40 to 100			Read

Menu code	Device function, Parameters	Description	Factory setting	Setting options	Read / Write
6.5.1.7	Gain up 4	Gain of fourth path up 0 to 255; optimal: 40 to 100			Read
6.5.1.8	Gain dw 4	Gain of fourth path down 0 to 128; optimal: 40 to 100			Read
6.5.1.9	Gain limit	A warning level for application control and diagnostics purposes	Depends on ordered sensor size	1 to 255	Write
6.5.2	Amplitudes				
6.5.2.1	Amp up 1	Amplitude of first path up 0 to 255; optimal: 95 to 105			Read
6.5.2.2	Amp dw 1	Amplitude of first path down 0 to 255; optimal: 95 to 105			Read
6.5.2.3	Amp up 2	Amplitude of second path up 0 to 255; optimal: 95 to 105			Read
6.5.2.4	Amp dw 2	Amplitude of second path down 0 to 255; optimal: 95 to 105			Read
6.5.2.5	Amp up 3	Amplitude of third path up 0 to 255; optimal: 95 to 105			Read
6.5.2.6	Amp dw 3	Amplitude of third path down 0 to 255; optimal: 95 to 105			Read
6.5.2.7	Amp up 4	Amplitude of fourth path up 0 to 255; optimal: 95 to 105			Read
6.5.2.8	Amp dw 4	Amplitude of fourth path down 0 to 255; optimal: 95 to 105			Read
6.5.3	Trigger level				
6.5.3.1	Trig up 1	Trigger level of first path up 0 - 128; typical: 40 – 100			Read
6.5.3.2	Trig dw 1	Trigger level of first path down 0 - 128; typical: 40 – 100			Read
6.5.3.3	Trig up 2	Trigger level of second path up 0 - 128; typical: 40 – 100			Read
6.5.3.4	Trig dw 2	Trigger level of second path down 0 - 128; typical: 40 – 100			Read
6.5.3.5	Trig up 3	Trigger level of third path up 0 - 128; typical: 40 – 100			Read
6.5.3.6	Trig dw 3	Trigger level of third path down 0 - 128; typical: 40 – 100			Read
6.5.3.7	Trig up 4	Trigger level of fourth path up 0 - 128; typical: 40 – 100			Read
6.5.3.8	Trig dw 4	Trigger level of fourth path down 0 - 128; typical: 40 – 100			Read
6.5.4	Error count %				

Menu code	Device function, Parameters	Description	Factory setting	Setting options	Read / Write
6.5.4.1	Error 1	Error totalizer in % for path 1 0-100%; optimal: 0%			Read
6.5.4.2	Error 2	Error totalizer in % for path 2 0-100%; optimal: 0%			Read
6.5.4.3	Error 3	Error totalizer in % for path 3 0-100%; optimal: 0%			Read
6.5.4.4	Error 4	Error totalizer in % for path 4 0-100%; optimal: 0%			Read
6.5.5	TOF up				
6.5.5.1	TOF up 1	TIME OF FLIGHT (TOF) (ns) of first path upstream			Read
6.5.5.2	TOF up 2	TIME OF FLIGHT (TOF) (ns) of second path upstream			Read
6.5.5.3	TOF up 3	TIME OF FLIGHT (TOF) (ns) of third path upstream			Read
6.5.5.4	TOF up 4	TIME OF FLIGHT (TOF) (ns) of fourth path upstream			Read
6.5.6	TOF down				
6.5.6.1	TOF dw 1	TIME OF FLIGHT (TOF) (ns) of first path downstream			Read
6.5.6.2	TOF down 2	TIME OF FLIGHT (TOF) (ns) of second path downstream			Read
6.5.6.3	TOF dw 3	TIME OF FLIGHT (TOF) (ns) of third path downstream			Read
6.5.6.4	TOF dw 4	TIME OF FLIGHT (TOF) (ns) of fourth path downstream			Read
6.5.7	delta TOF				
6.5.7.1	delta TOF 1	TIME OF FLIGHT (TOF) (ns) difference of first path (up - down)			Read
6.5.7.2	delta TOF 2	TIME OF FLIGHT (TOF) (ns) difference of second path (up - down)			Read
6.5.7.3	delta TOF 3	TIME OF FLIGHT (TOF) (ns) difference of third path (up - down)			Read
6.5.7.4	delta TOF 4	TIME OF FLIGHT (TOF) (ns) difference of fourth path (up - down)			Read
6.6	Zero Trim	Zero point values for track1 to path 4			
6.6.1	Zero Pt.Offset	Zero offset compensation value for each path			
6.6.1.1	Zr.Pt.Offset 1	Zero offset (ns) of first path	Depends on factory calibration, for example +0.000 ns	-50.000 ns to +50.000 ns	Write
6.6.1.2	Zr.Pt.Offset 2	Zero offset (ns) of second path	Depends on factory calibration, for example +0.000 ns	-50.000 ns to +50.000 ns	Write

Menu code	Device function, Parameters	Description	Factory setting	Setting options	Read / Write
6.6.1.3	Zr.Pt.Offset 3	Zero offset (ns) of third path	Depends on factory calibration, for example +0.000 ns	-50.000 ns to +50.000 ns	Write
6.6.1.4	Zr.Pt.Offset 4	Zero offset (ns) of fourth path	Depends on factory calibration, for example +0.000 ns	-50.000 ns to +50.000 ns	Write
6.6.2	Stand.Dev.	Standard deviation value for each path			
6.6.2.1	Stand.Dev. 1	Standard deviation for path 1; typical +0.000 ns			Read
6.6.2.2	Stand.Dev. 2	Standard deviation for path 2; typical +0.000 ns			Read
6.6.2.3	Stand.Dev. 3	Standard deviation for path 3; typical +0.000 ns			Read
6.6.2.4	Stand.Dev. 4	Standard deviation for path 4; typical +0.000 ns			Read
6.6.3	Zero calibr.	Initiates a device specific adjustment cycle (zero trim processing) that determines the true zero point value. Only to be performed at an absolute flowrate of zero!		Start Status is shown as: Running / Finished	Write
6.6.4	Undo zero cal.	Undo last zero trim		After choice shows "Zero Trim OK"	Write
6.7	Trim parameter				
6.7.1	Error Filter				
6.7.1.1	Val. uncertain	Error filter limit value uncertain (%) for the average quality of the ultrasonic measurement (signal pairs of up and down). Above this value the error status is set to uncertain and the warning is indicated (on display and output). The actual (maybe unstable) measured values are displayed	Depends on system configuration ordering, for example 50% for 2-path sensor system	1 %, 5 %, 10 %, 25 %, 50 %, 75 %, 90 %, 95 %, 99 %	Write
6.7.1.2	Value bad	Error filter value bad (%) with same function as described above. Additionally, the measured values are set to "0" in the display and the output signal to the error signal level	50 %	1 %, 5 %, 10 %, 25 %, 50 %, 75 %, 90 %, 95 %, 99 %, never	Write

C.1.7 Menu 7 - Sensor parameters

Note

Large sizes

With nominal diameter settings above DN 2000 the device may not work properly.

Menu code	Device function, Parameters	Description	Factory setting	Setting options	Read / Write
7.1	Sensor calibr.				
7.1.1	Calibr. choice	Calibration choice	AUTO (SONOKIT systems) WET (SONO 3100 and SONO 3300 systems)	WET AUTO	Write
7.1.2	App. param.				
7.1.2.1	Viscosity	Viscosity of media (cm ² /s, for example water at 20 °C is 0.01 cm ² /s)	0.01 cm ² /s	0.005 to 5 cm ² /s Optional in in ² /s	Write
7.1.2.2	Correct. fact.	Calibration factor compensation value for flow sensor to correct the measured values; typical: 1.0	1.0	0.000001 to 100	Write
7.1.2.3	Fl. offset comp.	Offset compensation value for flow sensor (in flow unit set in menu 3.1.1)	+0.00000 m ³ /h	-max. flow to +max. flow (see menu 3.1.2)	Write
7.1.2.4	Cable len. TOFKOR	Total cable length for a path (m). All paths must have the same length	Depending on selection (factory setting with the ordered transducer cable length)	0 to 500 m	Write
7.1.3	Pipe geometry				
7.1.3.1	Pipe diameter				
7.1.3.1.1	Engr.unit	Unit selection (m or in)	m	m in	Write
7.1.3.1.2	Pipe diameter	Inside diameter of pipe (m or in) With nominal diameter settings above DN 2000 the device may not work properly.	Depending on selection at ordering	0.01 to 4.0 m	Write
7.1.3.2	Roughness				
7.1.3.2.1	Engr.unit	Unit selection (mm or in)	mm	mm in	Write
7.1.3.2.2	Roughness	Roughness of the inner pipe wall (mm or in); for example 0.04 m for steel pipes	0.4 mm (0.015748 in)	0.01 to 10.0 mm	Write
7.1.4	Tracks				
7.1.4.1	Track 1				
7.1.4.1.1	Length 1	Length of path 1 (m). The distance between the two ultrasonic transducers of path 1, see Sensor parameters (menu 7) (Page 61).	Depending of sensor size selected at ordering	>0 to 8.0 m	Write
7.1.4.1.2	Angle 1	Angle of path 1	Depending of sensor size selected at ordering	0 to 89°	Write

Menu code	Device function, Parameters	Description	Factory setting	Setting options	Read / Write
7.1.4.1.3	Displacement 1	Displacement of path 1 (m) Note: The value must be smaller than the half entered pipe diameter (see menu 7.1.3.2.2). For 1-path the value must be set to 0	Depending of sensor size selected at ordering	0 to 1.5 m	Write
7.1.4.1.4	Trig. con 1 Up	The signal trigger constant of the first path up.	SONO 3100 and SONOKIT: -0.75 SONO 3100 (special applications): Depending on the ordered system SONO 3300: Depending on the ordered sensor	-1.40 to +1.40	Write
7.1.4.1.5	Trig. con 1 Dw	The signal trigger constant of the first path down.	SONO 3100 and SONOKIT: -0.75 SONO 3100 (special applications): Depending on the ordered system SONO 3300: Depending on the ordered sensor	-1.40 to +1.40	Write
7.1.4.1.6	AUTO cal. 1	The AUTO calibration factor is automatically calculated Note: Only shown if AUTO is selected in menu 7.1.1			Read
7.1.4.1.6	WET cal. 1	The WET calibration factor of the path. Note: Only shown if WET is selected in menu 7.1.1	Depending on factory calibration of the transmitter, which is typically done together with the ordered sensor	0.0000010 to 100.0000000 (value with 7 fractional digits)	Write
7.1.4.1.7	WET Flow 1	This value represents the calculated flow Note: Only shown if WET is selected in menu 7.1.1	Depending on factory calibration together with ordered sensor		Read
7.1.4.2	Track 2				
7.1.4.2.1	Length 2	Length of path 2 (m). The distance between the two ultrasonic transducers of path 2, see Sensor parameters (menu 7) (Page 61).	Depending of sensor size selected at ordering	>0 to 8.0 m	Write
7.1.4.2.2	Angle 2	Angle of path 2	Depending of sensor size selected at ordering	0 to 89°	Write

Menu code	Device function, Parameters	Description	Factory setting	Setting options	Read / Write
7.1.4.2.3	Displacement 2	Displacement of path 2 (m) Note: The value must be smaller than the half entered pipe diameter (see menu 7.1.3.2.2). For 1-path the value must be set to 0	Depending of sensor size selected at ordering	0 to 1.5 m	Write
7.1.4.2.4	Trig. con 2 Up	The signal trigger constant of the second path up.	SONO 3100 and SONOKIT: -0.75 SONO 3100 (special applications): Depending on the ordered system SONO 3300: Depending on the ordered sensor	-1.40 to +1.40	Write
7.1.4.2.5	Trig. con 2 Dw	The signal trigger constant of the second path down.	SONO 3100 and SONOKIT: -0.75 SONO 3100 (special applications): Depending on the ordered system SONO 3300: Depending on the ordered sensor	-1.40 to +1.40	Write
7.1.4.2.6	AUTO cal. 2	The AUTO calibration factor is automatically calculated Note: Only shown if AUTO is selected in menu 7.1.1			Read
7.1.4.2.6	WET cal. 2	The WET calibration factor of the path. Note: Only shown if WET is selected in menu 7.1.1	Depending on factory calibration of the transmitter, which is typically done together with the ordered sensor	0.0000010 to 100.0000000 (value with 7 fractional digits)	Write
7.1.4.2.7	WET Flow 2	This value represents the calculated flow Note: Only shown if WET is selected in menu 7.1.1	Depending on factory calibration together with ordered sensor		Read
7.1.4.3	Track 3				
7.1.4.3.1	Length 3	Length of path 3 (m). The distance between the two ultrasonic transducers of path 3, see Sensor parameters (menu 7) (Page 61).	Depending of sensor size selected at ordering	>0 to 8.0 m	Write
7.1.4.3.2	Angle 3	Angle of path 3	Depending of sensor size selected at ordering	0 to 89°	Write

Menu code	Device function, Parameters	Description	Factory setting	Setting options	Read / Write
7.1.4.3.3	Displacement 3	Displacement of path 3 (m) Note: The value must be smaller than the half entered pipe diameter (see menu 7.1.3.2.2).	Depending of sensor size selected at ordering	0 to 1.5 m	Write
7.1.4.3.4	Trig. con 3 Up	The signal trigger constant of the third path up.	SONO 3100 and SONOKIT: -0.75 SONO 3100 (special applications): Depending on the ordered system SONO 3300: Depending on the ordered sensor	-1.40 to +1.40	Write
7.1.4.3.5	Trig. con 3 Dw	The signal trigger constant of the third path down.	SONO 3100 and SONOKIT: -0.75 SONO 3100 (special applications): Depending on the ordered system SONO 3300: Depending on the ordered sensor	-1.40 to +1.40	Write
7.1.4.3.6	AUTO cal. 3	The AUTO calibration factor is automatically calculated Note: Only shown if AUTO is selected in menu 7.1.1			Read
7.1.4.3.6	WET cal. 3	The WET calibration factor of the path. Note: Only shown if WET is selected in menu 7.1.1	Depending on factory calibration of the transmitter, which is typically done together with the ordered sensor	0.0000010 to 100.0000000 (value with 7 fractional digits)	Write
7.1.4.3.7	WET Flow 3	This value represents the calculated flow Note: Only shown if WET is selected in menu 7.1.1	Depending on factory calibration together with ordered sensor		Read
7.1.4.4	Track 4				
7.1.4.4.1	Length 4	Length of path 4 (m). The distance between the two ultrasonic transducers of path 4, see Sensor parameters (menu 7) (Page 61).	Depending of sensor size selected at ordering	>0 to 8.0 m	Write
7.1.4.4.2	Angle 4	Angle of path 4	Depending of sensor size selected at ordering	0 to 89°	Write
7.1.4.4.3	Displacement 4	Displacement of path 4 (m) Note: The value must be smaller than the half entered pipe diameter (see menu 7.1.3.2.2).	Depending of sensor size selected at ordering	0 to 1.5 m	Write

Menu code	Device function, Parameters	Description	Factory setting	Setting options	Read / Write
7.1.4.4.4	Trig. con 4 Up	The signal trigger constant of the fourth path up.	SONO 3100 and SONOKIT: -0.75 SONO 3100 (special applications): Depending on the ordered system SONO 3300: Depending on the ordered sensor	-1.40 to +1.40	Write
7.1.4.4.5	Trig. con 4 Dw	The signal trigger constant of the fourth path down.	SONO 3100 and SONOKIT: -0.75 SONO 3100 (special applications): Depending on the ordered system SONO 3300: Depending on the ordered sensor	-1.40 to +1.40	Write
7.1.4.4.6	AUTO cal. 4	The AUTO calibration factor is automatically calculated Note: Only shown if AUTO is selected in menu 7.1.1			Read
7.1.4.4.6	WET cal. 4	The WET calibration factor of the path. Note: Only shown if WET is selected in menu 7.1.1	Depending on factory calibration of the transmitter, which is typically done together with the ordered sensor	0.0000010 to 100.0000000 (value with 7 fractional digits)	Write
7.1.4.4.7	WET Flow 4	This value represents the calculated flow Note: Only shown if WET is selected in menu 7.1.1	Depending on factory calibration together with ordered sensor		Read
7.2	No. of tracks	Number of paths connected to the transmitter; typical 1-track (SONO 3100, SONOKIT-1) or 2-tracks (SONO 3100, SONO 3300, SONOKIT-2)	Depending on ordered system configuration	1-track 2-tracks 3-tracks 4-tracks	Write

Index

C

- Catalog
 - catalog sheets, 83
- CE mark, 14
- Certificates, 83
- Commissioning
 - Safety, 37
 - with PDM, 43
- Compliance, 13
 - European directives, 14
- Connection
 - Electrical, (See Electrical connection)
- Contact person, 11
- Customer Support, (Refer to Technical support)

D

- Device
 - Identification, 21
- Downloads, 83

E

- Electrical connection
 - Basic requirements, 29
 - Safety, 29
- Error symptoms, 71

F

- Flow factor, 22
- Flow velocity, 22

H

- Hazardous area
 - Temperature specifications, 16
- Hazardous area Approvals, 14
 - Safety requirements, 16
- History, 7
- Hotline, (Refer to Support request)

I

- Identification nameplate
 - Sensor, 21
- Installation
 - Indoor/outdoor, 25
 - Pipe mounting, 27
- Internet
 - Contact person, 10
 - Flow documentation, 10
- Intrinsically safe data, 15

L

- Laws and directives, 13
- Local display
 - Turn, 28

M

- Maintenance, 67
- Manuals, 83
- Material compatibility, 13
- Measuring principle, 22

P

- PDM
 - Commissioning, 43

R

- Return procedure, 67

S

- Safety, 13
 - Instrument safety standards, 13
- Scope of delivery, 8
- Service, 84
 - Application information, 73
- Service and support
 - Internet, 84
- Support, 84
- Support request, 84

T

Technical support, 84
 partner, 84
 personal contact, 84
Temperature specifications, 16
Transit time, 22

W

Warranty, 10
Wiring, (See Electrical connection)