

Ultrasonic flowmeters

SITRANS FUS080 transmitter for use with sensor type
SITRANS F US SONOKIT

Operating Instructions • 07/2012



SITRANS F

SIEMENS

SIEMENS

SITRANS F

Ultrasonic Flowmeters SITRANS FUS080 transmitter

Operating Instructions



<u>Introduction</u>	1
<u>Safety notes</u>	2
<u>Description</u>	3
<u>Installing/Mounting</u>	4
<u>Connecting</u>	5
<u>Commissioning</u>	6
<u>Functions</u>	7
<u>Service and maintenance</u>	8
<u>Troubleshooting/FAQs</u>	9
<u>Technical data</u>	10
<u>Qualification certificate</u>	11
<u>Parameter lists</u>	A
<u>Settings</u>	B

Ultrasonic flow transmitter type FUS080 for use with
sensor type SITRANS F US SONOKIT.

Legal information

Warning notice system

This manual contains notices you have to observe in order to ensure your personal safety, as well as to prevent damage to property. The notices referring to your personal safety are highlighted in the manual by a safety alert symbol, notices referring only to property damage have no safety alert symbol. These notices shown below are graded according to the degree of danger.

 DANGER
indicates that death or severe personal injury will result if proper precautions are not taken.
 WARNING
indicates that death or severe personal injury may result if proper precautions are not taken.
 CAUTION
indicates that minor personal injury can result if proper precautions are not taken.
NOTICE
indicates that property damage can result if proper precautions are not taken.

If more than one degree of danger is present, the warning notice representing the highest degree of danger will be used. A notice warning of injury to persons with a safety alert symbol may also include a warning relating to property damage.

Qualified Personnel

The product/system described in this documentation may be operated only by **personnel qualified** for the specific task in accordance with the relevant documentation, in particular its warning notices and safety instructions. Qualified personnel are those who, based on their training and experience, are capable of identifying risks and avoiding potential hazards when working with these products/systems.

Proper use of Siemens products

Note the following:

 WARNING
Siemens products may only be used for the applications described in the catalog and in the relevant technical documentation. If products and components from other manufacturers are used, these must be recommended or approved by Siemens. Proper transport, storage, installation, assembly, commissioning, operation and maintenance are required to ensure that the products operate safely and without any problems. The permissible ambient conditions must be complied with. The information in the relevant documentation must be observed.

Trademarks

All names identified by ® are registered trademarks of Siemens AG. The remaining trademarks in this publication may be trademarks whose use by third parties for their own purposes could violate the rights of the owner.

Disclaimer of Liability

We have reviewed the contents of this publication to ensure consistency with the hardware and software described. Since variance cannot be precluded entirely, we cannot guarantee full consistency. However, the information in this publication is reviewed regularly and any necessary corrections are included in subsequent editions.

Table of contents

1	Introduction	7
1.1	Items supplied	7
1.2	History	9
1.3	Further Information	10
2	Safety notes	11
2.1	Laws and directives	11
2.2	Lithium batteries.....	12
2.3	Installation in hazardous area	12
2.4	Certificates	13
3	Description	15
3.1	System components	15
3.2	Design	16
3.3	Features	16
3.4	Principle of operation	17
4	Installing/Mounting	19
4.1	Installing FUS080.....	19
5	Connecting	21
5.1	Wiring the transducer cables	22
5.2	Wiring the power supply and the output	25
5.2.1	Wiring the power supply.....	25
5.2.2	Wiring the pulse output	28
5.2.3	Mounting the transmitter	28
6	Commissioning	29
6.1	Operating the local display.....	29
6.2	Navigating the menu structure.....	31
6.3	Start-up routine	31
6.4	Commissioning via PDM.....	32
6.4.1	Installing and connecting the IrDA interface adapter	33
6.4.2	Installing the device driver	34
6.4.3	Adding the device to the network.....	34
6.4.4	Configuring the device	34
6.4.5	Optimizing the system.....	40
6.4.6	Checking the operation readiness	41
6.4.7	Qualification certificate.....	42

7	Functions	45
7.1	Unit selection	45
7.2	Number of decimal digits	45
7.3	Password-protected data	46
7.4	Hardware key	47
8	Service and maintenance	49
8.1	Maintenance	49
8.2	Battery replacement	49
8.3	Technical support	52
8.4	Application-specific data	53
8.5	Return procedures	53
8.6	Battery disposal	54
8.7	Disposal	54
9	Troubleshooting/FAQs	55
9.1	Error codes	55
9.2	Diagnosing with PDM	57
10	Technical data	61
10.1	SITRANS FUS080	61
10.2	Battery	62
10.3	Sensor geometrical data	63
10.4	Dimensions	64
11	Qualification certificate	65
A	Parameter lists	69
A.1	Identification	69
A.2	Output	71
A.3	Diagnostic	73
A.4	Meter setup	78
A.5	Human Interface	80
A.6	Unit conversion table	81
B	Settings	83
B.1	Factory settings	83
B.2	Factory settings for MODBUS communication	84
B.3	Measurement report, SONOKIT 2-path	85
B.4	Dimension dependent settings, SONOKIT 2-path	86
B.5	Measurement report, SONOKIT 1-path	88

B.6	Dimension dependent settings, SONOKIT 1-path.....	89
B.7	Ordering	90
Index		91

Introduction

These instructions contain all the information you need for using the device.

The instructions are aimed at persons mechanically installing the device, connecting it electrically, configuring the parameters and commissioning it, as well as service and maintenance engineers.

Note

It is the responsibility of the customer that the instructions and directions provided in the operating instructions are read, understood, and followed by the relevant personnel before installing the device.

1.1 Items supplied

- SITRANS FUS080 transmitter
- Wall/pipe mounting kit with bracket and terminal box
- SITRANS F US literature CD
- Transducer coaxial cables
- Application label
- SONOKIT installation kit (not shown)
- Operating Instructions



Note

The scope of delivery may vary, depending on version and add-ons. The contents list in the package lists all included parts.

Inspection

Before installing the flowmeter check the following:

1. Check for mechanical damage due to possible improper handling during shipment. All claims for damage are to be made promptly to the shipper.
2. Make sure the scope of delivery and the information on the nameplates correspond to the ordering information.

Identification

The FUS080 transmitter is delivered with two different labels. The transmitter nameplate (silver) is placed on the front of the transmitter. The system nameplate (white) is placed on the right side of the transmitter. Both labels provide valuable information about the device and system.

In the following the system nameplate is described.

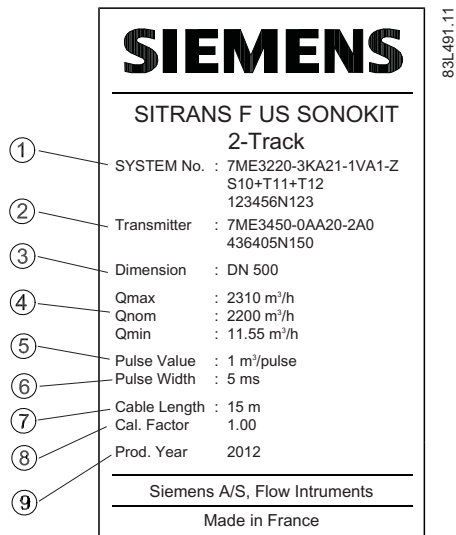

- ① System number (order code identifying selected options and system serial number)
- ② Transmitter production code and serial number
- ③ Dimension (nominal size ordered)
- ④ Maximum flow value
Nominal flow value
Minimum flow value
- ⑤ Pulse value (output A)
- ⑥ Pulse width (output A)
- ⑦ Cable length (one transducer cable)
- ⑧ Calibration factor
- ⑨ Production year

Figure 1-1 Example of system nameplate

Application label

The application label is supplied with the device and can be used to show the local application settings of the transmitter. It is recommended to fill in this label with the application values and place it on the left side of transmitter.

SIEMENS	
SITRANS F US SONOKIT 2-Track	
SYSTEM No.: 7ME3220-3KA21-1VA1-Z S10+T11+T12 123456N123	
Application Values:	
Dimension _____	Pulse Value _____ m ³ /pulse
Qmax _____ m ³ /h	Pulse Width _____ m ^s
Qnorm _____ m ³ /h	Cable Length _____ m
Qmin _____ m ³ /h	Cal. Factor _____
Installation date _____	
Siemens A/S, Flow Instruments	
Made in France	

Figure 1-2 Application label

1.2 History

The contents of these instructions are regularly reviewed and corrections are included in subsequent editions. We welcome all suggestions for improvement.

The following table shows the most important changes in the documentation compared to each previous edition.

Edition	Remarks	FW version	EDD version
07/2012	First edition	2.03	01-02-07

The documentation of this edition is applicable for the firmware stated in the table.

Note

A flowmeter system consists of a sensor retrofit kit (SONOKIT) and a transmitter (FUS080).

These Operating Instructions only cover the transmitter part of the system. The sensor part has a separate manual, which is available on the SITRANS F US literature CD-ROM and on the flowdocumentation website (<http://www.siemens.com/flowdocumentation>)

1.3 Further Information

Product information on the Internet

The Operating Instructions are available on the CD-ROM shipped with the device, and on the Internet on the Siemens homepage, where further information on the range of SITRANS F flowmeters may also be found:

Product information on the internet (<http://www.siemens.com/flow>)

Worldwide contact person

If you need more information or have particular problems not covered sufficiently by these Operating Instructions, get in touch with your contact person. You can find contact information for your local contact person on the Internet:

Local contact person (<http://www.automation.siemens.com/partner>)

 CAUTION
Correct, reliable operation of the product requires proper transport, storage, positioning and assembly as well as careful operation and maintenance. Only qualified personnel should install or operate this instrument.

Note

Alterations to the product, including opening or improper modifications of the product, are not permitted.

If this requirement is not observed, the CE mark and the manufacturer's warranty will expire.

2.1 Laws and directives

General requirements

Installation of the equipment must comply with national regulations. For example EN 60079-14 for the European Community.

Instrument safety standards

The device has been tested at the factory, based on the safety requirements. In order to maintain this condition over the expected life of the device, the requirements described in these Operating Instructions must be observed.

NOTICE
Material compatibility
Siemens Flow Instruments can provide assistance with the selection of wetted sensor parts. However, the full responsibility for the selection rests with the customer and Siemens Flow Instruments can take no responsibility for any failure due to material incompatibility.

CE-marked equipment

The CE mark symbolizes the compliance of the device with the following guidelines:

- EMC guideline 89/336/EWG
- Low voltage guideline 73/23/EWG
- Pressure equipment directive (PED/DGRL) 93/23/EG

2.2 Lithium batteries

Lithium batteries are primary power sources with high energy content designed to represent the highest possible degree of safety.

 WARNING
Potential hazard Lithium batteries may present a potential hazard if they are abused electrically or mechanically. This is in most circumstances associated with the generation of excessive heat where internal pressure may cause the cell to rupture. Thus the following basic precautions should be observed when handling and using lithium batteries: <ul style="list-style-type: none">• Do not short-circuit, recharge or connect with false polarity.• Do not expose to temperature beyond the specified temperature range or incinerate the battery.• Do not crush, puncture or open cells or disassemble battery packs.• Do not weld or solder to the battery's body.• Do not expose contents to water.

2.3 Installation in hazardous area

 WARNING
NOT allowed for use in hazardous areas! Equipment used in hazardous areas must be Ex-approved and marked accordingly! This device is NOT approved for use in hazardous areas!

2.4 Certificates

Certificates are posted on the Internet and on the documentation CD-ROM shipped with the device.

See also

Certificates (<http://www.siemens.com/processinstrumentation/certificates>)

Description

SITRANS F US ultrasonic flowmeters measure flow in standard volumetric units. The measurement is independent of changes in liquid temperature, density, pressure and conductivity. The flowmeter is designed for use on single phase liquids.

They are designed for measurement of:

- Volume flow rate
- Bidirectional flow measurement
- Total volume

The specific calibration for the SONOKIT pipe installation is done by carefully measuring the sensor geometry and manual programming of mechanical/geometrical pipe data via the software tool SIMATIC PDM* in the transmitter.

*PDM: Process Device Manager (software programming tool)

Main applications

The main application for flowmeters with the transmitter SITRANS FUS080 is measurement of water flow in district heating plants, local networks, boiler stations, substations, chiller plants, irrigations plants, and other general water applications.

3.1 System components

The 1-path or 2-path ultrasonic flowmeter system SITRANS F US SONOKIT with transmitter SITRANS FUS080 includes:

- Battery or mains-powered transmitter (type SITRANS FUS080)
- Sensor retrofitting set type SITRANS F US SONOKIT (1-path for pipe diameters from DN 100 (4") up to DN 1200 (48") or for 2-path from DN 200 (8") up to DN 1200 (48"))
- MODBUS RTU (RS 485 or RS 232) optional communication module (to be mounted into the wall mounting kit)



Figure 3-1 SITRANS FUS080 with SONOKIT mounting parts

Communication solutions

The transmitter supports MODBUS RTU communication via the optical IrDA interface at the display, enabling the change of different transmitter settings using the SIMATIC PDM software tool.

The transmitter provides two pulse outputs for volume pulses or alarm. Optionally, a MODBUS RTU communication module (RS 485 or RS 232) can be installed to enable communication directly between a PLC/RTU and the transmitter.

3.2 Design

The SITRANS FUS080 transmitter is designed with fiberglass reinforced polyamide enclosure for remote or compact installation. The remote versions are available with up to 30 meter distance from flowmeter to transmitter. When ordering as a compact version in the series FUS380 and FUE380 the transducer cables are pre-mounted at the sensor.



SITRANS FUS080 transmitter



SITRANS FUS080 Display

The transmitter is available in an IP67 (NEMA 4X/6) enclosure and is designed for use in the flowmeters series:

- SONOKIT (1-path or 2-path)
- FUS380 (2-path)
- FUE380 (2-path)

3.3 Features

The following features are available:

- Battery or mains-powered
- Battery-powered with 3.6 V Lithium dual D-cell batteries
- Suitable for pipe diameters from DN 100 (4") up to DN 1200 (48") (SONOKIT 1-path) or DN 200 (8") up to DN 1200 (48") (SONOKIT 2-path)
- IP67 (NEMA 4X/6) rated polyamid enclosure

- Factory preset to the nominal dimensions of pipe type and pipe size
- Manual programming of mechanical/geometrical pipe data via SIMATIC PDM
- Local control panel with single push button, 8-digit display and IrDA optical interface for communication with SIMATIC PDM
- Display showing accumulated volume as well as instantaneous flow rate. The displayed units are m³/h and m³
- Two digital outputs for volume pulse or alarm
- Optional field bus communication module (MODBUS RTU) for direct communication with a PLC/RTU. Recommended use of such options are with mains-powered versions.

3.4 Principle of operation

Physical principle

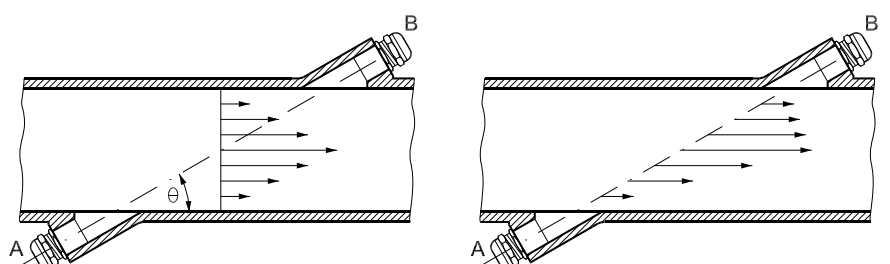

Figure 3-2 Velocity distribution along sound path

A sound wave travelling in the same direction as the liquid flow arrives at point B from point A in a shorter time than the sound wave travelling against the direction of flow (from point B to A).

The difference in sound transit time indicates the flow velocity in the pipe.

Since delay time is measured at short intervals both in and against flow direction, temperature has no influence on measurement accuracy.

SITRANS F US flowmeters

In SITRANS F US flowmeters the ultrasonic transducers are placed at an angle θ in relation to the pipe axis. The transducers function as transmitters and receivers of the ultrasonic signals. Measurement is performed by determining the time the ultrasonic signal takes to travel with and against the flow. The principle can be expressed as follows:

$$v = K \times (t_{B,A} - t_{A,B}) / (t_{A,B} \times t_{B,A}) = K \times \Delta t / t^2$$

where

v = Average flow velocity

t = Transit time

K = Proportional flow factor

3.4 Principle of operation

This measuring principle offers the advantage that it is independent of variations in the actual sound velocity of the liquid, i.e. independent of the temperature.

The proportional flow factor K is determined by wet calibration or calculated by "Auto" in case of manual programming of mechanical/geometrical pipe data (SONOKIT only). The transducer angle (θ), distance between sensors (L) and pipe dimension (D_i and D_u) are shown in the figure below.

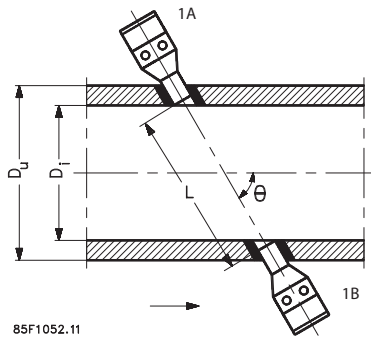
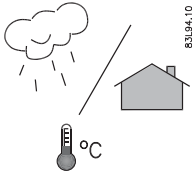

Figure 3-3 Measuring principle

The ultrasonic signal is sent directly between the transducers. The advantage gained sending signals from point to point is an extremely good signal strength.

Installing/Mounting



SITRANS F flowmeters are suitable for indoor and outdoor installations.

- The SITRANS FUS080 has the following temperature specifications:
 - Ambient temperature: -5 to +60 °C (23 to 140 °F)
- The enclosure rating is IP67 (NEMA 4X/6) or better.

NOTICE
Make sure that the pressure and temperature specifications indicated on the device nameplate/label will not be exceeded.
NOTICE
Direct sunlight
Do not expose the device to direct sunlight!

4.1 Installing FUS080

Note

Sensor installation

It is required that the sensor has been installed according to the relevant operating instructions and that the sensor measurement report has been completed!

1. Mount wall/pipe mounting bracket in an appropriate place

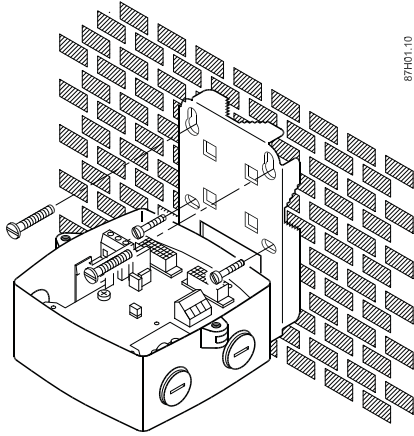

Wall mounting

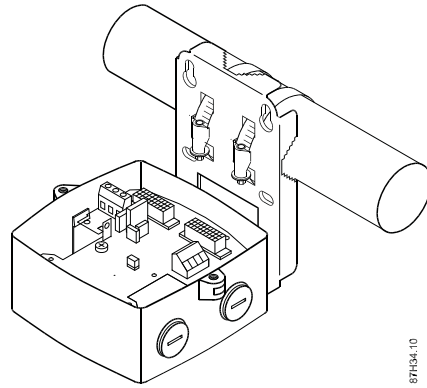

Pipe mounting

Note

Take coaxial cable length into consideration, and allow adequate space for cable inlets underneath and on both sides.

Connecting

This chapter describes how to wire up the device using the following steps:

1. Wiring the transducer cables (Page 22)
2. Wiring the power supply and the output (Page 22)

Note

Connection of the transducers to the SONOKIT is described in the separate sensor operating instructions.

Safety measurements

 WARNING
Only qualified personnel may carry out work on the electrical connections.

 WARNING
Danger of electric shock!
Never install the device with the mains voltage switched on!

Cable specifications

- The line length from the cable gland to the terminals must be kept as short as possible. Line loops in the terminal box must be avoided.
- Lay heat-resistant transducer cables if high temperatures can occur on the housing, e.g. due to conduction of heat by the sensor/metering tube. Lay the cables so that they do not come into contact with the hot sensor/metering tube.
- Lay signal and transducer cables separately from cables with voltages > 60 V.
- To guarantee the IP67 (NEMA 4X/6) degree of protection, use cables with the required specifications

Note

Transmitter grounding

To ensure identical potential for sensor and transmitter, a direct grounding of transmitter and sensor is recommended.

 **WARNING**

Protective conductor terminal

The required cable is min. AGW16 or 1.5 Cu.

 **WARNING**

Wire insulation

The insulation between the connected mains supply and the low voltage supply for the flowmeter must be rated with at least double or reinforced insulation at mains voltage.

For field wiring installation: Ensure that the **National Installation Code** of the country in which the flowmeters are installed is met.

5.1 Wiring the transducer cables

The system SONOKIT with FUS080 transmitter is supplied with separate transducer coaxial cables:

- 2 cables for 1-path

and

- 4 cables for 2-path

The cables can be used on all transducers (cables are not paired with a specific transducer).

The cables are manufactured with crimp on the cable ends for the connection board.

Note

If the cables are shortened, all cables must be shortened equally, and the factory set cable length must be changed accordingly in the transmitter.

Connecting the cables to the wall/pipe mounting kit

1. Snap out connection plate and loosen grounding wire.

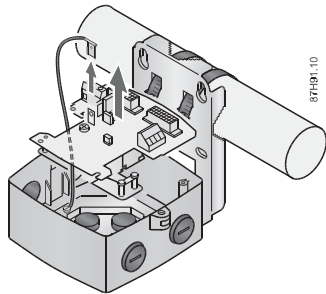

2. Smoothly push cables one by one from underneath base through glands and adjust all cable ends approximately 100 mm from upper frame of base.

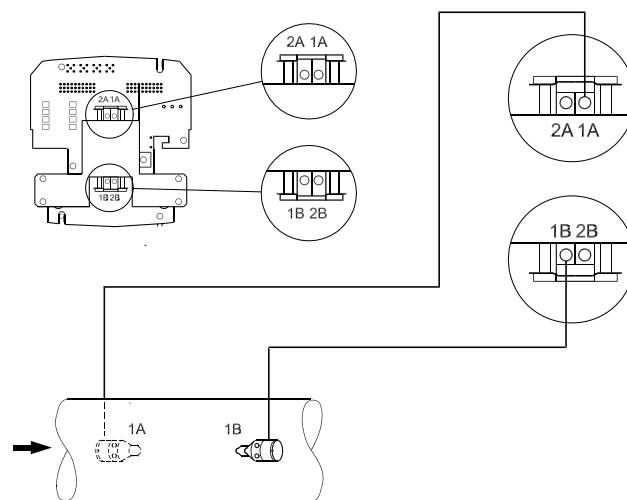
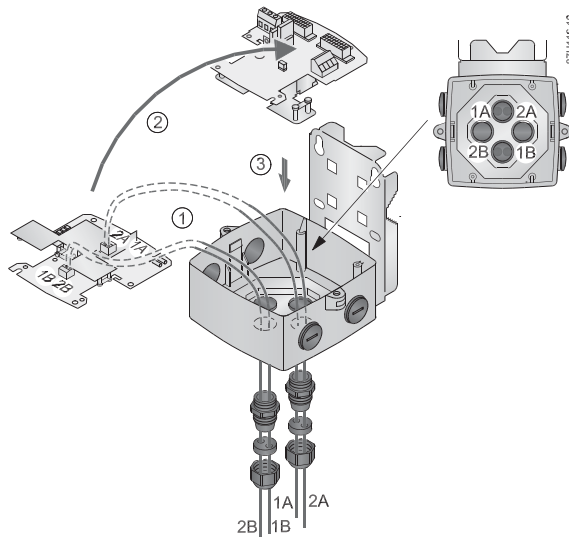

Figure 5-1 Electrical connection to SONOKIT 1-path

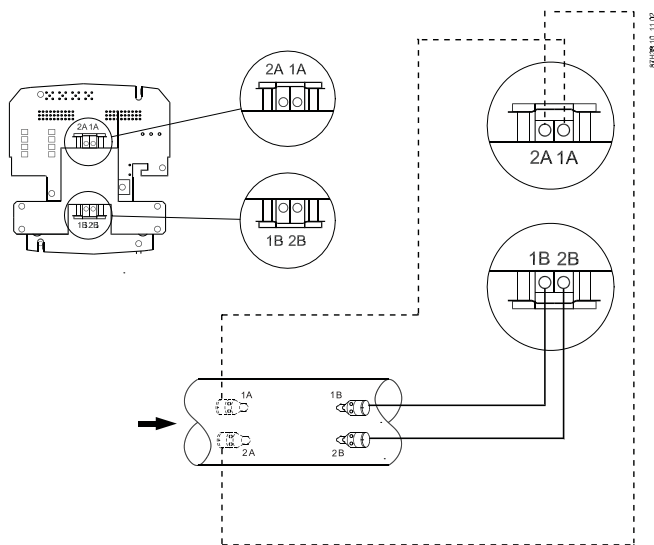

Figure 5-2 Electrical connection to SONOKIT 2-path

Note

Ensure that the right cable entries are used.

- 1-path:
 - Terminal 1A is connected to transducer 1A
 - Terminal 1B is connected to transducer 1B
- 2-path:
 - As 1-path and additionally:
 - Terminal 2A is connected to transducer 2A
 - Terminal 2B is connected to transducer 2B

Note

For sensor (transducer) connection, see SONOKIT 1-path or SONOKIT 2-path Operating Instructions.

3. Remount connection board in wall/pipe mounting kit.

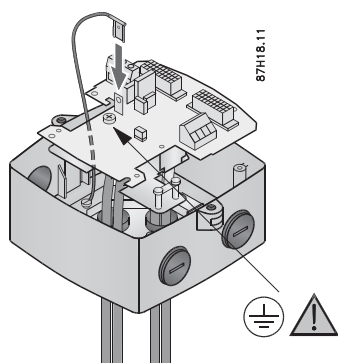

4. Ground transmitter via grounding terminal (PE) on PCB.

Note**Sensor grounding**

To ensure identical potential for sensor and transmitter, a direct grounding of transmitter and sensor is recommended.

5. Tighten both transducer cable glands.

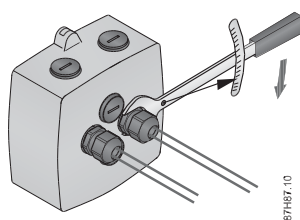

6. Make sure that transducer cables are not overbent. Minimum cable bend radius is 50 mm.

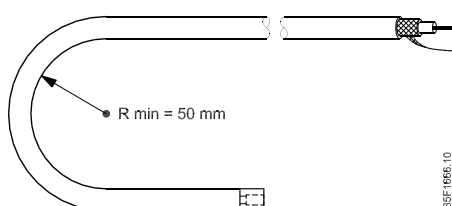

5.2 Wiring the power supply and the output

The wiring of the power supply and the output is done in three steps:

1. Wiring the power supply
2. Wiring the pulse output (if relevant)
3. Mounting the transmitter

5.2.1 Wiring the power supply

 WARNING

Make sure the power supply requirements stated on the nameplates are met!

5.2 Wiring the power supply and the output

The transmitter is available in three versions:

- Battery-powered only
- Mains-powered
- Mains-powered with battery back-up

Determine the transmitter power source type by reading the nameplate or via the product code.

Note

Change of power source

The specified type of power supply cannot be altered. E.g. a battery-powered transmitter cannot be upgraded with additional mains power.

1. Wire battery (battery-powered versions only).

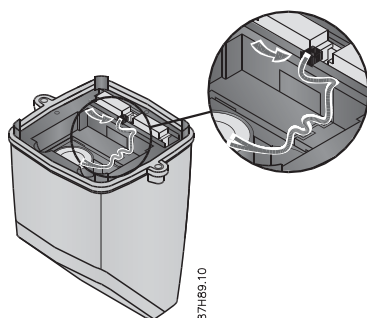

Figure 5-3 Wiring the battery

2. Connect power supply to L1, N and protective earth (PE) (mains-powered versions only).

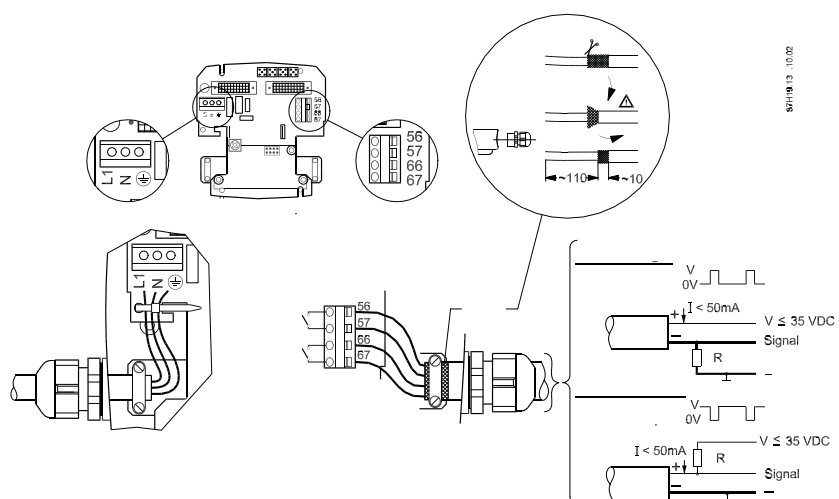

Figure 5-4 Power supply and output connection

NOTICE
Cable straps
It is recommended to use cable straps.

3. Fix power supply cable to terminal housing with clamp (mains-powered versions only).

5.2.2 Wiring the pulse output

⚠ CAUTION
Pulse output
The pulse output must be connected to equipment complying with Low Voltage Directive in order to be considered safe. The isolation within the FUS080 pulse output is only a functional isolation.

1. Prepare cable ends as shown above.
2. Connect output cables to terminals 56 and 57 (Output A) and to 66 and 67 (Output B) according to use. The output functions are used as shown above.
3. Ground cable shielding by fixing it with clamp.

⚠ CAUTION
EMC performance
Incorrect fixing of the cable shield will affect the EMC performance!

5.2.3 Mounting the transmitter

1. Tighten power supply and pulse output cable glands.
2. Mount transmitter.

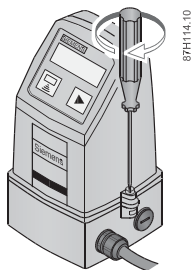

Figure 5-5 Mounting the transmitter on terminal box

Commissioning

Commissioning the device includes the following steps:

1. Resetting the battery lifetime ("Start-up routine" (Page 31)).
2. Configuring the device via SIMATIC PDM ("Commissioning via PDM" (Page 32)).

Before commissioning, a basic guide to the local display and the menu structure is offered in the chapters:

"Operating the local display"

"Navigating the menu structure"

6.1 Operating the local display

The local display is divided into 3 areas:

- Top area with symbols for status information
- Mid area with actual readings
- Lower area with index number of the shown menu

Activate the push button to go the next index menu and related information.

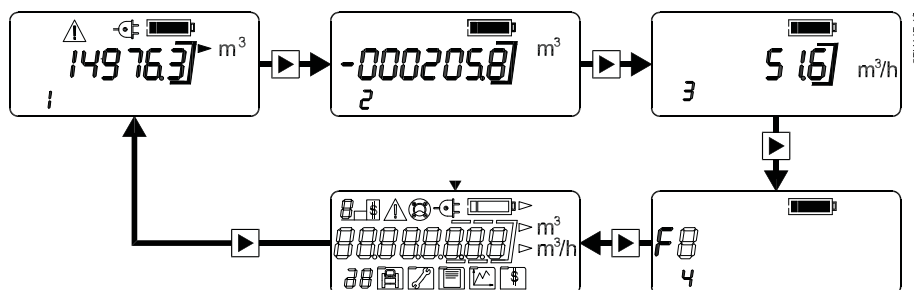

Operating the local display

Table 6- 1 Information symbols

Symbol	Description
	Mains power supply connected
	Battery charge status
	Warning

Battery status



There are two symbols for battery charge status:

- "Battery full" indicates battery charge above the warning level (6-year hour counter).
- "Battery low" indicates battery charge below the warning level and that the battery should be replaced.

Note

"Battery low" only indicates that battery charge is below a pre-set level, not that charge is zero. Flow measurement continues uninterrupted until the battery is completely drained.

Table 6- 2 Information symbols

Symbol	Description
	Battery status, full
	Battery status, low

Note

Change of settings and parameters





The measured values are shown on the local display. Display settings as for example hiding specific menus cannot be changed via the local display.

- Access and change display settings, set parameters, and locate and diagnose failures via the IrDA optical interface and SIMATIC PDM.
-

6.2 Navigating the menu structure

Use the push button to navigate between the following menu items:

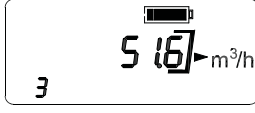
Table 6-3 Menu items

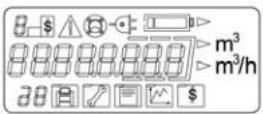
Menu	Parameter	Display example	Comments
Menu 1	Flow volume totalizer 1		Factory preset is forward volume flow. The battery symbol shows full.
Menu 2	Flow volume totalizer 2		Factory preset for reverse flow. Negative values indicate reverse flow calculation.
Menu 3	Actual flow rate		Negative values indicate reverse flow calculation..
Menu 4	Alarm codes		Each code refers to a specific alarm.
Menu 5	Display test		Check of all segments. Display toggles between all segments on/off.

6.3 Start-up routine

1. Power-up device.
2. Reset battery status indicator as described below (battery-powered versions only).

Resetting the battery counter

Note

The reset can also be carried out via SIMATIC PDM.

When new batteries are installed and the plug is connected, the transmitter start-up routine begins. The display shows the active software version, e.g. 2.03.

After ten seconds the message "reset.bat" will appear.

1. Press push button within six seconds to reset the internal battery counter. The message "accept" will appear.
2. Press push button again within six seconds in order to reset the internal battery counter. The battery indicator now shows full. If the push button is not pressed again, the battery indicator will show "Low".

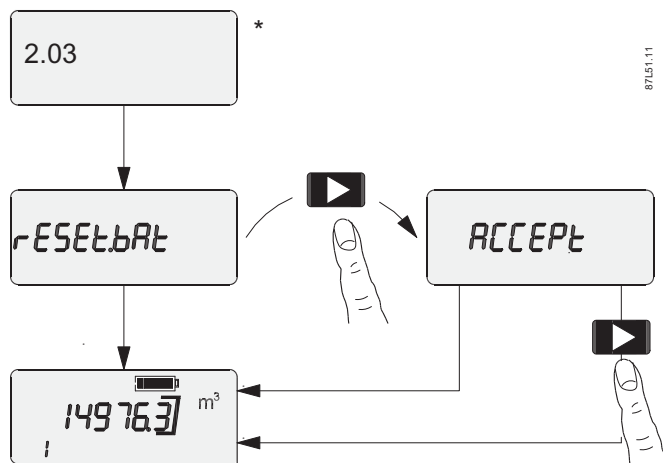

Figure 6-1 Reset internal battery counter

* Software version

6.4 Commissioning via PDM

SIMATIC PDM (Process Device Manager) is a software package for configuring, parameterizing, commissioning, and maintaining field devices (e.g. transducers).

Among other features, SIMATIC PDM contains a simple process for monitoring process values, interrupts and status/diagnosis signals of a field device.

Note

For instructions on installation and operation of SIMATIC PDM, refer to the SIMATIC PDM Getting Started (included in the documentation package that comes with PDM).

Note

Minimum PDM version required is SIMATIC PDM V6.0 + SP5

Note

Default password

Any data changes in PDM requires a password. The default password is 1000. For further information, see "Password-protected data" (Page 46).

In the following it is described how the device is commissioned using SIMATC PDM.

The commissioning is divided into the following steps:

1. Installing and connecting in the IrDA interface adapter
2. Installing the device driver (Page 34)
3. Adding the device to the network (Page 34)
4. Configuring the device (Page 34)
5. Optimizing the system (Page 40)
6. Checking the operation readiness (Page 41)

6.4.1 Installing and connecting the IrDA interface adapter

Note

IrDA driver installation

For installation of the IrDA driver, refer to the instructions delivered with the adapter.

1. Connect IrDA adapter to PC

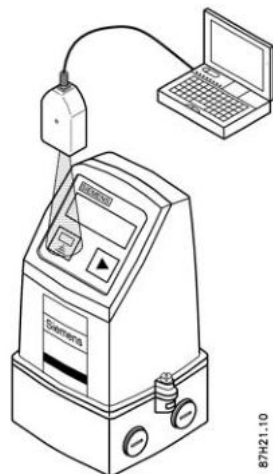

2. Mount adapter on FUS080

When the IrDA adapter is connected correctly, a small icon appears on the taskbar of your PC. When the mouse is placed on this icon, the device information will be shown (e.g. "FUS080 SN1033 is in range").



6.4.2 Installing the device driver

Install the PDM device driver as follows:

1. Download update from the Internet on SITRANS F US downloads (<http://support.automation.siemens.com/WW/view/en/16889017/133100>), or copy it from supplied CD into envisaged folder and unzip the file. Check that the EDD is the version valid for the device.
2. Open "Manage Device Catalog" from Start → SIMATIC → SIMATIC PDM.
3. Navigate to PDM device driver, select device and click "OK". The driver is installed on the PC.

6.4.3 Adding the device to the network

It is recommended to configure the FUS080 project in PDM before setting the parameters.

1. Add device to SIMATIC MODBUS network:
 - Select "File" → "New"
Type in a project name, e.g. SONOKIT
 - Right click on "Net" and select "Insert New Object" → "Modbus Net".
Your PC is now added to the Modbus Net
 - Right click on "Modbus Net" and select "Insert New Object" → "Modbus Device"
 - Click on "Assign" and assign the Modbus device to SITRANS FUS/E080 (Sensors → Flow → Ultrasonic → SIEMENS AG → SITRANS FUS/E080) and click "OK".
Rename device according to application requirements (max. 32 characters).
Set up communication parameters for SIMATIC MODBUS network
 - Select "Net" → "Modbus Net", right click on "Modbus net" and select "Object Properties"
 - Select "Connection" to activate IrDA

6.4.4 Configuring the device

In the following it is described how to configure the device by defining all sensor specific parameters.

Note

Measurement accuracy

A correct sensor installation and a completed measurement report containing correctly defined sensor-specific data is required to ensure optimum measurement accuracy.

- For further information, refer to the sensor operating instructions.
 - For allowed inaccuracies, refer to "Sensor geometrical data" (Page 63).
-

Read all parameters

Before any parameterization is done it is necessary to read all parameters from the device into the offline table of SIMATIC PDM. The offline table merely contains default data.

1. Open PDM device driver.
2. Select "Upload to PC/PG .." Select "Execute even if the device TAG does not match the project data TAG.", and click "OK" to read all parameters to the offline table.
After closing the dialog box, all loaded parameters should show "Loaded" in the status of the PDM table. For a complete parameter list, see "Parameter list" (Page 69).
3. Store factory set default values on your local PC ("File" → "Export") in order to be able to retrieve default settings.

Read, write device data

Only parameters (data) shown with white background can be changed.

Note**Status field**

- "Changed" indicates off-line data not yet stored in the device.
 - "Loaded" indicates actual device data.
-

Parameter	Value	Unit	Status
SITRANS FUS080			
DD-Version	01.02.07		Initial value
» Identification			
1 Application identifier	Identity		Loaded
2 Application location	Location		Loaded
» » Device			
5 Sensor size	DN200		Loaded
8 Totalizer unit	m3		Loaded
9 Flowrate unit	m3/h		Loaded
10 Qmax (105% of Qs)	399,000000	m3/h	Loaded
373 Low flow cut-off	0,250000	%	Loaded
20 Vendor name	SIEMENS A/S		Loaded
21 Module type	SONOKIT/FUS880		Loaded
22 Software version	2.03		Loaded
23 Product code number	7ME32202FA111VA1		Loaded
24 System Serial number	000000N000		Loaded
25 Transmitter serial number			Loaded
505 Device Product ID	Vendor id: 042; Product id: 028		Loaded
» Output			
» » Operation			
100 Actual date and time	15-08-2011 07:23:10		Loaded
101 Totalizer 1	0,444444	m3	Loaded
102 Totalizer 2	0,000000	m3	Loaded
103 Customer totalizer 3	0,444444	m3	Loaded
104 Reset customer totalizer 3	No		Loaded
105 Customer totalizer 3 reset date	18-03-2011 10:18:08		Loaded
106 Flow rate	0,000000	m3/h	Loaded
107 Relative flow rate	0	%	Loaded
108 Actual velocity for track 1	0	m/s	Loaded
109 Actual velocity for track 2	0	m/s	Loaded
110 Track 1 gain step	15		Loaded
111 Track 2 gain step	15		Loaded

To view possible settings, right-click and select "Help".

For overview of the parameters see "Parameter list" (Page 69).

Set sensor-related parameters

1. Select "Device"→"Pipe geometric assistant" in order to calculate:
 - Rn for path 1 and 2 (pipe constant in line 304 and 305)
 - Calibration Factor (Flow-Profile-Factor for retrofit, line 310)
 - Diameter (line 306)
2. Define sensor-specific parameters based on data from the sensor measurement report and the selection made at ordering:
 - Select metric (m, m/s) or imperial (in, ft/s) units for data entry. Internal calculation in the device is made in metric units only.
 - Enter outer pipe diameter (D_u) and average pipe wall thickness (t).
 - Flow velocity (V) is automatically calculated using entered pipe data and given Q_{max} (PDM parameter row 10).
 - Enter media viscosity in cSt (e.g. 1 cSt for water at 20 °C).
 - Enter the pipe roughness value.
The pipe-roughness default value is automatically set according to pipe material or can be entered manually by selecting "User defined" (range: 0.0000 to 0.0100 m).

Pipe material	Typical roughness
Smooth plastic pipe (select PVC)	0.0001 m
Polished stainless steel pipe	0.0001 m
Standard carbon steel pipe (select STEEL)	0.0004 m
Rusty carbon steel pipe	0.001 ... 0.002 m
Concrete pipe (Select CONCRETE)	0.002 ... 0.005 m

3. Depending on the SONOKIT type (1-path or 2-path), enter additional sensor data:

Parameter	1-path	2-path
Number of paths	1	2
Outer pipe diameter	D_U	D_U
Pipe wall thickness	t	t
Average path distance*	H	H
Path 1 angle	A_1	A_1
Path 2 angle	-	A_2
Average transducer 1 distance	L_1	L_1
Average transducer 2 distance	-	L_2
Velocity (auto calculated with Q_{max})	V	V

* For crossed paths solutions with no path displacement: Enter "0".

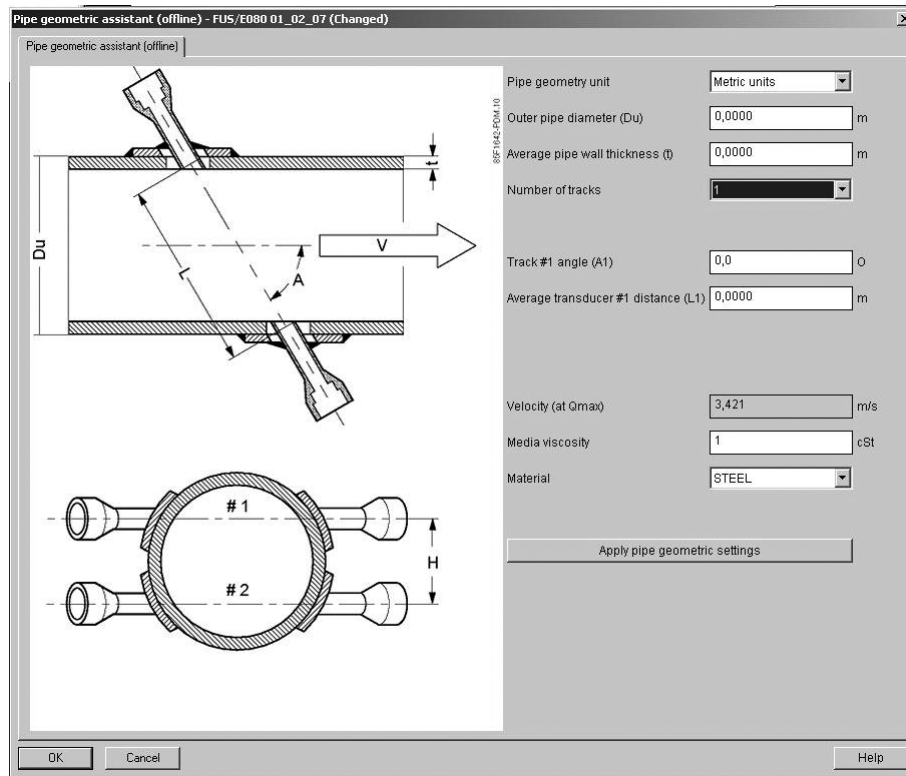

Figure 6-2 1-path sensor data

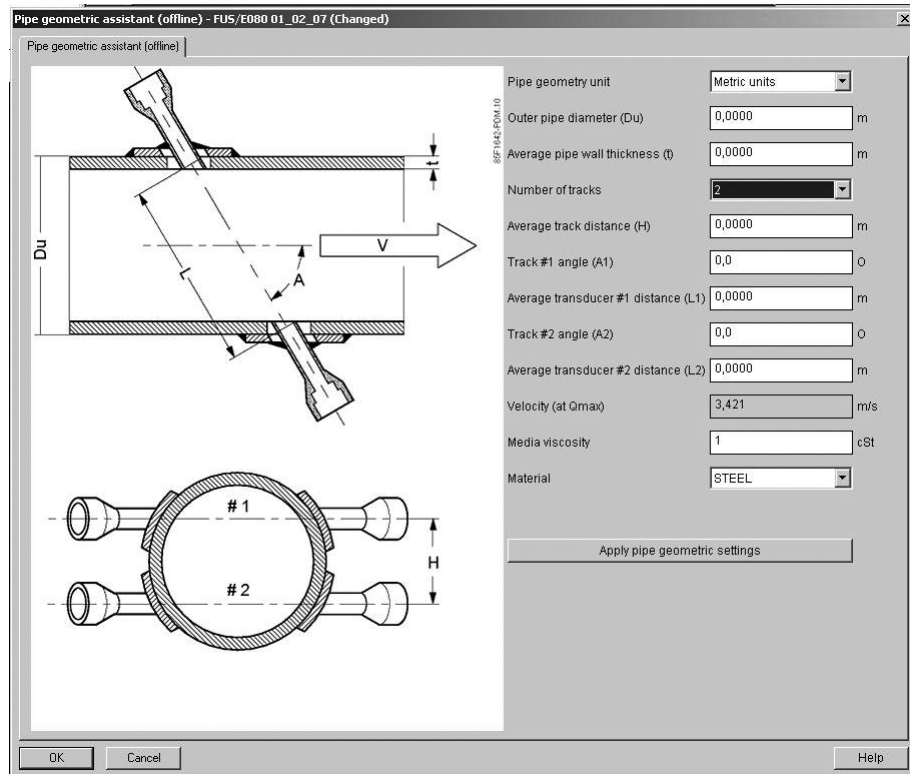

Figure 6-3 2-path sensor data

4. Click on "Apply pipe geometric settings" and then on "OK" to transfer the data into appropriate "Value" and "Unit" cells. Values are transferred and shown in metric units only. Close the pipe geometric tool dialog box by clicking on "OK". Click "OK" to confirm the data entered.

Parameter	Value	Unit	Status
» Meter Setup			
307 Flow velocity offset	0,000000	m/s	Loaded
310 Calibration factor	0,990788		Changed
311 Adjustment Factor	1,000000		Loaded
312 Transducercable length	15,000000	m	Loaded
372 Filter time constant	15,000000	s	Loaded
380 Protect linearization from user access	No		Loaded
» » Totalizer			
400 Flow direction totalizer 1	Forward		Loaded
401 Totalizer 1 change date	30-06-2011 13:36:04		Loaded
410 Flow direction totalizer 2	Reverse		Loaded
411 Totalizer 2 change date	30-06-2011 13:36:04		Loaded
» » Pipe data			
300 Number of tracks	2		Loaded
302 Max sample frequency	15	Hz	Loaded
303 Sample frequency	0,5	Hz	Loaded
304 Rn for track 1	1,045982	m	Changed
305 Rn for track 2	1,045982	m	Changed
306 Inner pipe diameter	0,498000	m	Changed

Figure 6-4 Changed values successfully transferred

Clicking on "Apply pipe geometric settings" will initiate automatic calculation of the following:

- R_n for path 1 and path 2
- Cal. factor

For further information, see:

Dimension dependent settings, SONOKIT 2-path (Page 86) or SONOKIT 1-path (Page 89).

Measurement report, SONOKIT 2-path (Page 85) or SONOKIT 1-path (Page 88).

6.4.5 Optimizing the system

After defining the sensor-specific parameters, additional parameters can be set according to use.

The following shows how to set Pulse Output A and Qmax.

For other parameters, refer to "Parameter lists (Page 69).

Setting Pulse Output and Maximum Flow (Qmax)

1. Navigate to menu "Device" → "Pulse guide"
The "guide" calculates the pulse-frequency at the max flow condition and tells you how close you are on over-speeding the pulse-output.
The volume per pulse is freely scalable from 0.000001 to 10000 units per pulse. It also calculates the minimum volume per pulse you can choose to avoid pulse over-speeding.
The maximum output frequency depends on the pulse selected; e.g. maximum output frequency at 5 ms is 100 Hz. Increasing the pulse width lowers the maximum output frequency.
2. Select maximum flow rate (never to be exceeded).
3. Select an appropriate pulse width, e.g. 5 ms.
4. Enter a value in "Amount per pulse A", e.g. 100, to define the volume/pulse with respect to the "Minimum amount per pulse value".
5. Press "Apply Change of Pulse" to apply the settings.
6. If needed, proceed with setting Pulse Output B according to application specific requirements (Default setting = Alarm).

6.4.6 Checking the operation readiness

All parameters are now set and defined according to the application.

1. Select: "Device" → "Download to device..." to download the parameters to the device.

Note

Before downloading the parameters, check that all listed data are loaded or changed and in accordance with the application requirements.

2. Select "Execute even if the device TAG does not match the project data TAG." and click "OK" to download all changes from the table to the device.

View process values

The system is now ready for normal operation.

1. Select "View" → "Display" to see all measured process values.
2. Verify that the fields show the expected values.

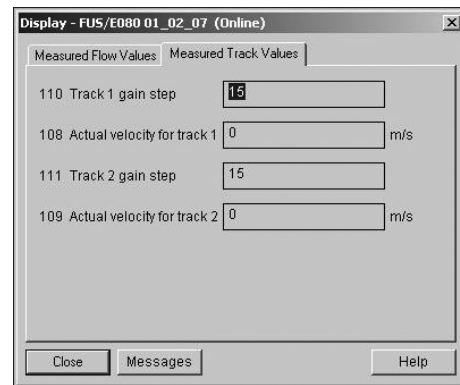
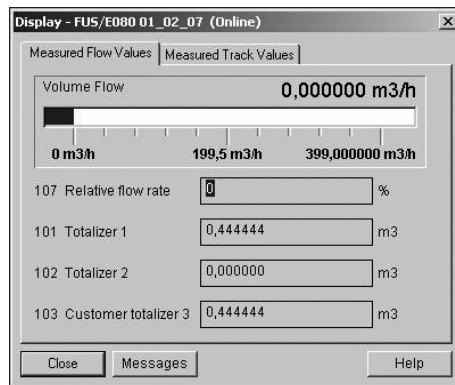

Note

Measured Track Values

The "Measured Track Values" should show stable values within the normal range, i.e. the gains should be stable values between 3 and 12 (smaller sizes low values and larger sizes high values) and the actual velocities for the paths should be stable, constant and smoothly changing values between 0 and 10 m/s.

Store settings on the PC

Store the device settings after verifying the values.

- Choose: "Read" → "Upload to PC" to get all the settings.
- Store the complete settings on your PC via "File" → "Export".

6.4.7 Qualification certificate

For your convenience you may create a qualification certificate (Page 65)

1. Click on "Device" → "Qualification Certificate".

Parameter	Value	Unit	Status
SITRANS FUS080			
Version	01.02.07		Initial value
Identification			
Application identifier	Identity		Loaded
Application location	Location		Loaded
Device			
Sensor size	DN200		Loaded
Totalizer unit	m3		Loaded
Flowrate unit	m3/h		Loaded
Qmax (105% of Qs)	399,000000	m3/h	Loaded
Low flow cut-off	0,250000	%	Loaded
Output			
21 Module type	SONOKIT/FUS880		Loaded
22 Software version	2.03		Loaded
23 Product code number	7ME32202FA111VA1		Loaded
24 System Serial number	000000N000		Loaded
25 Transmitter serial number			Loaded
505 Device Product ID	Vendor id: 042, Product id: 028		Loaded

2. Click on "Generate qualification certificate".

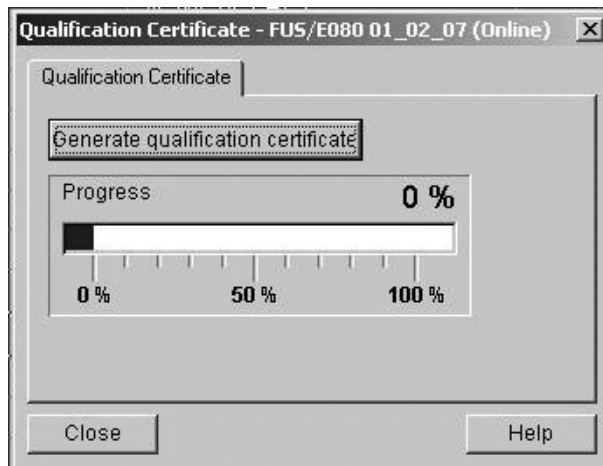

3. Click on "Close".

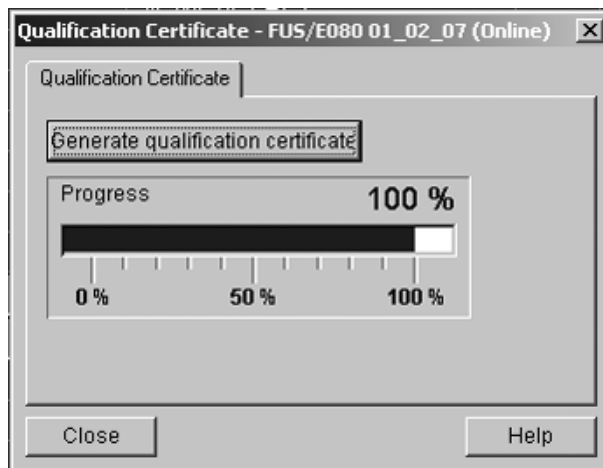

The Qualification Certificate is now available via Microsoft Word.

Functions

7.1 Unit selection

The device is delivered with totalizer and flow rate units in m and m³/h, respectively, as standard. However, it is possible to manually configure the device to operate with other units.

Changing the units

Go via PDM menu "Device" → "Unit guide". Select the new unit from the list and click on "Apply Change of Units". The change should be stored into the transmitter via "Device" → "Download to Device" afterwards.

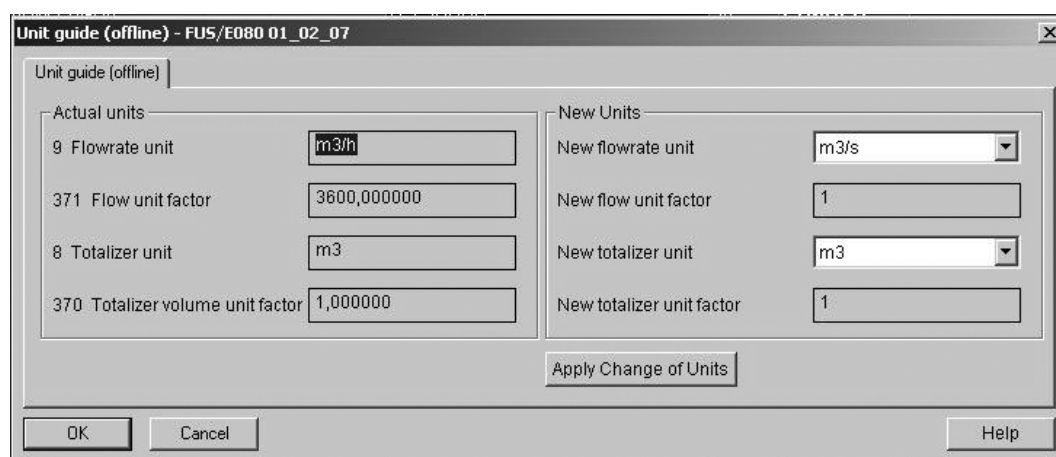

Figure 7-1 Unit selection

Note

The display is only able to show m³ and m³/h

If the units are changed to units other than m³ and m³/h, the display will not show any unit indication after the measured value on the display. To show the new customer unit on the display, a sticker can be used to show units. This sticker should be affixed to the transmitter display.

7.2 Number of decimal digits

For the display values (totalizers in menu 1 and 2 and flow in menu 3) "Auto adjust decimal point" is the default setting. This means that the number of digits after the decimal point automatically will be reduced with increasing number of digits before the decimal point.

7.3 Password-protected data

In the MODBUS communication via SIMATIC PDM, the flowmeter information is protected by a password. The default password is "1000" and it can be changed after gaining access to the flowmeter or via the PDM menu "Device" → "Change Password". **The password can be changed without the use of the HW key.**

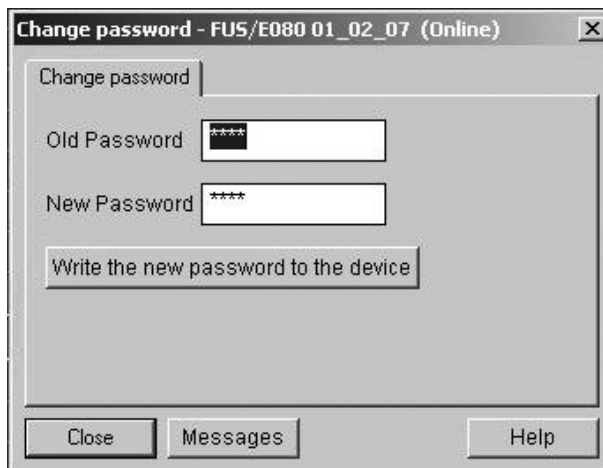

Figure 7-2 Change password

Click "Write new password to the device" and "Close"

7.4 Hardware key

HW key

To gain access to protected parameters of the transmitter, a hard-ware jumper (HW key) must be installed as shown below. The HW key place is located internally on the right top part of PCB behind the display as shown.



Figure 7-3 HW key behind the display (pins to the right)

Note Important

In this mode, with the HW key installed, many parameters in PDM are opened. If these parameters are changed, it can seriously affect the meter accuracy and operation. Be careful when writing new parameters.

Changing the HW-protected parameters

1. Disconnect power supply to transmitter, i.e. battery plug and/or the mains power supply
2. Remove frame and display from transmitter.
3. Insert HW key as shown in figure above.
4. Remount display and frame on transmitter.
5. Restart device.
6. Make parameter changes via PDM.
7. Download parameter changes to device.
8. Remove HW key by following the steps above.

Service and maintenance

8.1 Maintenance

The device is maintenance-free. However, a periodic inspection according to pertinent directives and regulations must be carried out.

An inspection can include check of:

- Ambient conditions
- Seal integrity of the process connections, cable entries, and cover screws
- Reliability of power supply, lightning protection, and grounds

NOTICE
Repair and service must be carried out by Siemens authorized personnel only.

Note

Siemens defines flow sensors as non-repairable products.

8.2 Battery replacement

NOTICE
It is recommended to replace the battery pack every 6 years.

Note

Battery lifetime

The battery lifetime depends on the use of the different functions, e.g. the use of MODBUS communication will decrease the lifetime significantly, see "Technical data" (Page 31)

For the use of add-on modules with MODBUS communication, the use of mains-powered transmitters is recommended. Typical lifetime of a dual battery pack with nominal working pulse output frequency of 20 Hz is approximately 4.2 years.

1. Unscrew battery cover and remove old battery pack.

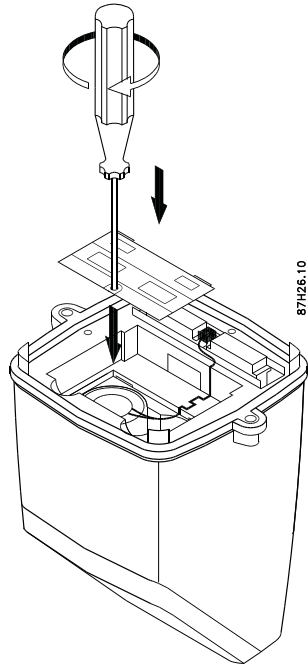

2. Fit new battery pack in transmitter

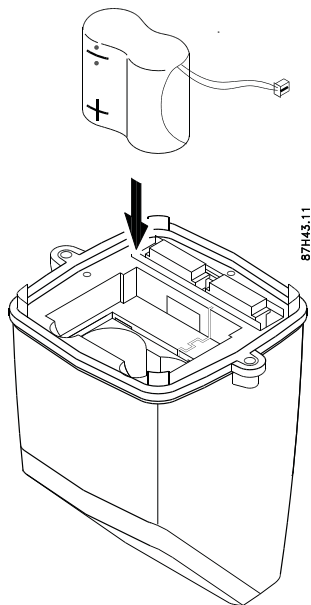

3. Connect battery.
Ensure that wire is inserted into small channel leading from plug to battery.

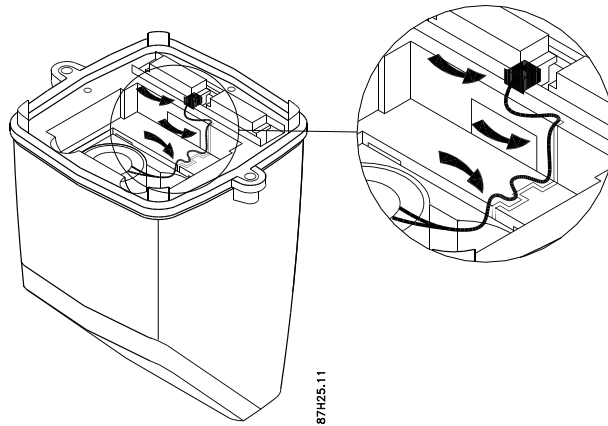

4. Remount battery cover.

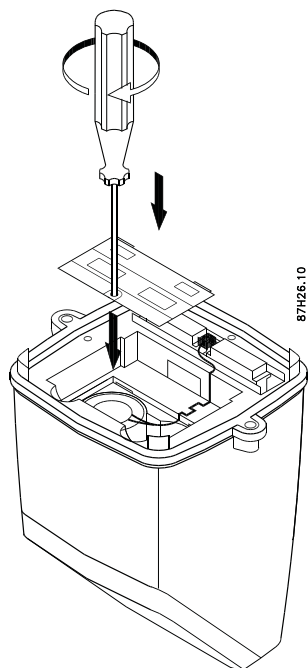

Note

Every time a battery is fitted and connected, the unit runs a start-up routine.

A battery replacement does not influence accumulated process values. Accumulated values can only be reset using SIMATIC PDM.

Resetting the internal battery counter

After replacing the batteries, reset the internal battery counter (Page 31) in order to indicate the power capacity correctly.

8.3 Technical support

If you have any technical questions about the device described in these Operating Instructions and do not find the right answers, you can contact Technical Support:

- Via the Internet using the **Support Request**:
Support request (<http://www.siemens.com/automation/support-request>)
- Via Phone:
 - Europe: +49 (0)911 895 7222
 - America: +1 423 262 5710
 - Asia-Pacific: +86 10 6475 7575

Further information about our technical support is available in the Internet at Technical support (<http://support.automation.siemens.com/WW/view/en/16604318>)

Service & Support on the Internet

In addition to our documentation, we offer a comprehensive knowledge base online on the Internet at:

Service and support (<http://www.siemens.com/automation/service&support>)

There you will find:

- The latest product information, FAQs, downloads, tips and tricks.
- Our newsletter, providing you with the latest information about your products.
- A Knowledge Manager to find the right documents for you.
- Our bulletin board, where users and specialists share their knowledge worldwide.
- You can find your local contact partner for Industry Automation and Drives Technologies in our partner database.
- Information about field service, repairs, spare parts and lots more under "Services."

Additional Support

Please contact your local Siemens representative and offices if you have additional questions about the device

Find your contact partner at:

Local contact person (<http://www.automation.siemens.com/partner>)

8.4 Application-specific data

In case the device needs service, the technical support team will typically request information about the application and the flowmeter.

- Prepare a sketch of the installation / application.
- Prepare a qualification certificate
 - Open SIMATIC PDM.
 - Select "Device" → "Qualification Certificate" and download certificate as a Word file.
 - Fill in required information.

See example of qualification certificate in "Qualification certificate" (Page 65).

8.5 Return procedures

Enclose the delivery note, the cover note for return delivery together with the declaration of decontamination form on the outside of the package in a well-fastened clear document pouch.

Required forms

- **Delivery Note**
- **Cover Note for Return Delivery** with the following information
Return delivery form (<http://support.automation.siemens.com/WW/view/en/16604370>)
 - product (ordering number)
 - number of devices or spare parts returned
 - reason for the return
- **Declaration of Decontamination**
Decontamination declaration
(http://pia.khe.siemens.com/efiles/feldg/files/Service/declaration_of_decontamination_en.pdf)
With this declaration you certify that the returned products/spare parts have been carefully cleaned and are free from any residues.
If the device has been operated together with toxic, caustic, flammable or water-damaging products, clean the device before return by rinsing or neutralizing. Ensure that all cavities are free from dangerous substances. Then, double-check the device to ensure the cleaning is completed.
We will not service a device or spare part unless the declaration of decontamination confirms proper decontamination of the device or spare part. Shipments without a declaration of decontamination will be cleaned professionally at your expense before further proceeding.

You can find the forms on the Internet and on the CD delivered with the device.

Note

Return of products with Lithium batteries

Lithium batteries are certified as dangerous goods according to the Regulation of Dangerous Goods, UN 3090 and UN 3091. Special transport documentation is required to observe these regulations.

Therefore it is recommended to remove lithium batteries prior to shipment

If the battery is important for the examination of the product and it cannot be removed, the product has to be returned according to the Regulation of Dangerous goods.

8.6

Battery disposal



In accordance with EU directive 2006/66/EC, batteries are not to be disposed of using municipal waste disposal services.

Waste industrial batteries are accepted back by Siemens or by the local Siemens representative. Please talk to your local Siemens contact (<http://www.automation.siemens.com/partner>) or follow the return procedures (Page 53) of Siemens Flow Instruments.

8.7

Disposal



Devices identified by this symbol may not be disposed of in the municipal waste disposal services under observance of the Directive 2002/96/EC on waste electronic and electrical equipment (WEEE).

They can be returned to the supplier within the EC or to a locally approved disposal service. Observe the specific regulations valid in your country.

Troubleshooting/FAQs

In case of an error, the device provides error codes via the display. The error codes are also available via SIMATIC PDM.

Furthermore, in case the device is not measuring correctly, a diagnostic function is available via the SIMATIC PDM.

9.1 Error codes

A list of errors is available in SIMATIC PDM (active errors are check-marked). Access to this list is gained via "Device" → "Device Status". In the figure below, error codes F 1, F 2 and F 5 are active.

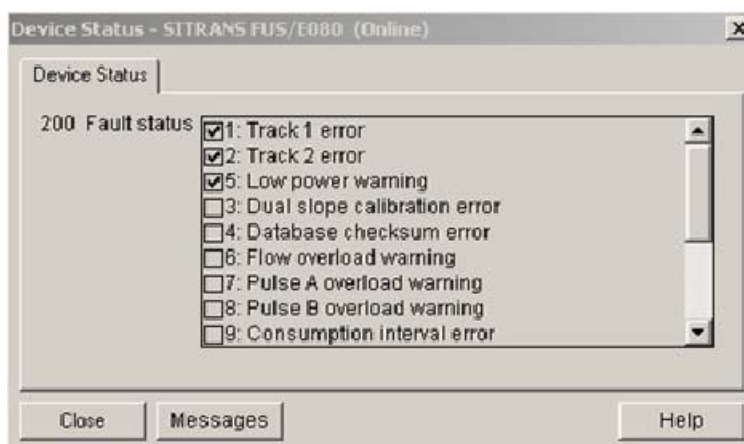

Figure 9-1 List of errors shown in PDM

9.1 Error codes

Table 9- 1 Error codes shown in the display and in PDM

Error code	Error	Remedy / Cause
Blank display	Battery plug not connected, or battery empty, mains power interrupted	<ul style="list-style-type: none"> • Check flowmeter version. Battery version not able to run on mains power • Battery empty: Replace battery pack • Battery plug not plugged into the transmitter, see "Battery replacement"
F 1	Path 1 (upper path) not measuring	No water in upper part of pipe and/or cables or transducer 1A or 1B defective
F 2	Path 2 (lower path) not measuring	No water in lower part of pipe and/or cables or transducer 2A or 2B defective
F 3	Internal software failure	Contact Siemens customer support
F 4	Internal software failure	Contact Siemens customer support
F 5	Power supply warning	<ul style="list-style-type: none"> • Mains power fails (only mains-powered versions with battery back-up) • Replace battery pack (battery-powered versions only)
F 6	Flow exceeds preset flow rate in unit (max. speed 10 m/s)	Flowrate too high
F 7	Pulse output A overflow	Pulse output exceeds 100 Hz or 50% duty cycle
F 8	Pulse output B overflow	Pulse output exceeds 100 Hz or 50% duty cycle
F 9	Datalogger warning/alarm	<p>Datalogger warning monitors whether actual consumption on Totalizer 1 is on end of log interval or above/below the limit settings.</p> <p>The warning has no influence on the flowmetering.</p> <p>Check data logger values and consumption limit (via PDM parameter 602)</p>

Errors "F 1" to "F 4" affect the performance of the meter and the flowmeter may stop measuring.
 Errors "F 1" and "F 2" disappear when the alarm condition is corrected.
 Errors "F 5" to "F 9" are only warnings and do not affect the measurement, but they will influence the outputs.
 The error indications disappear when the alarm conditions are corrected and a reset via the communication interface has been carried out.

Example

Error code "F 1 2" in the display indicates a combination of error codes "F 1" and "F 2".

Possible causes:

- Empty pipe
- Path 1 and path 2 cables defective
- Path 1 and path 2 cables not connected
- Transducers defective.

9.2 Diagnosing with PDM

SIMATIC PDM is a suitable tool for diagnosing the device. You can use SIMATIC PDM to read all parameters available in FUS080 to a table for analyzing offline, view online/actual process values and online/actual diagnostic information.

Requirements

The following procedure must be completed before diagnosing:

- Connection of Modbus interface via PC and IrDA, see also "Commissioning via PDM (Page 32)
- Installation of PDM and FUS080 PDM driver, see also "Installing the device driver (Page 34)

Diagnosing with PDM

Online process values are available under menu "View" → "Display".

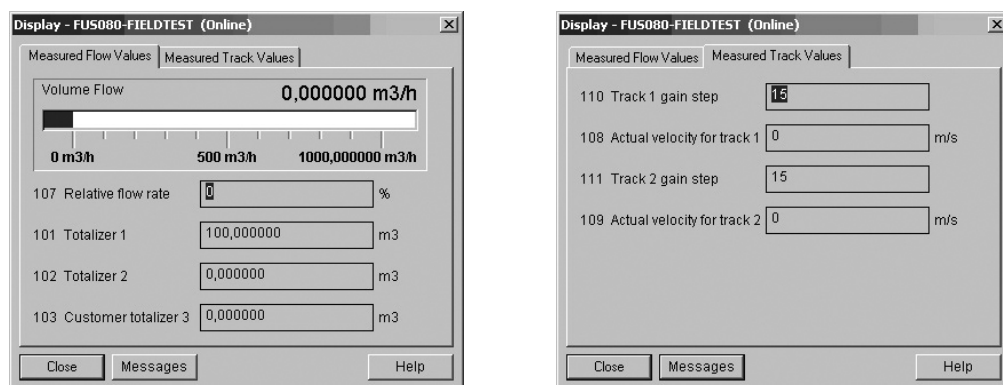

The "Measured Track Values" tab shows the gain steps and the flow velocities for path 1 and path 2. For 1-path applications the values for path 2 (track 2) are "0".

The gain steps depend on the pipe size and the conditions of the measuring media.

The flow velocities depend on the flow in the pipe.

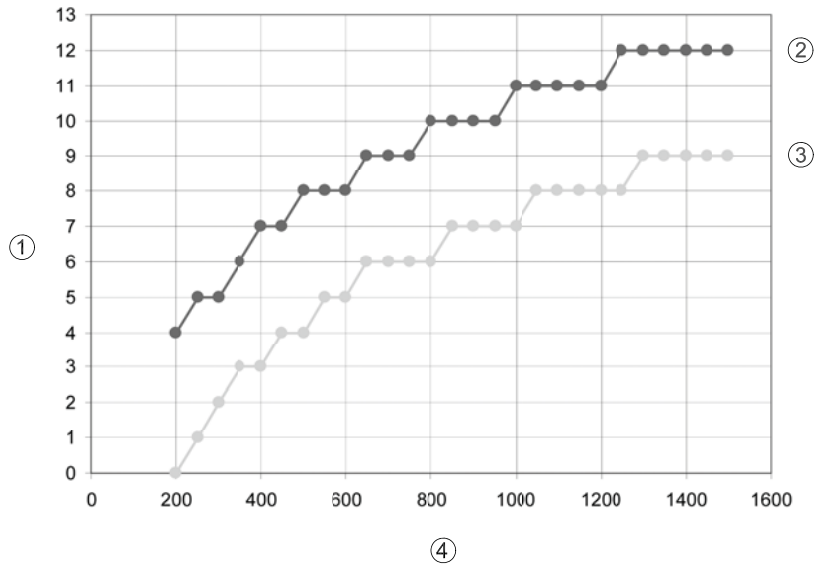

- ① Gain step
- ② Gain step max
- ③ Gain step min
- ④ Transducer distance [mm]

Figure 9-2 SITRANS FU080 Gain step vs. Transducer distance

Gain step

The graph above shows which gain step to expect for a particular transducer distance (face to face distance). The upper curve indicates the upper limit and the lower curve indicates the lower limit.

The graph applies to perfectly aligned transducers in clean water, but takes into account the expected variance from the converter and the transducers.

Gain step error conditions

Condition	Cause
15	<ul style="list-style-type: none"> • No transducer (e.g. defective cable) • Empty pipe
High values	<ul style="list-style-type: none"> • High damping (e.g. inhomogeneous media) • Unsuitable medium • Path angular misalignment
Unstable/fluctuating values	<ul style="list-style-type: none"> • Air bubbles or solids in medium • Bad inlet conditions
Δ gain step between path 1 and path 2 > 1 (2-path systems only)	<ul style="list-style-type: none"> • Bad inlet conditions • Inhomogeneous medium • Path angular misalignment

In case of angular misalignment between transducer faces, the gain step will increase as shown in the table below:

Angular misalignment	Gain step increase
2°	1
3°	2
4°	3
5°	5

Flow velocity error conditions

Condition	Cause
Δ flow velocity values (between path 1 and path 2) > 1 (2-path systems only)	<ul style="list-style-type: none"> • Bad inlet conditions (the higher the delta, the worse the inlet conditions) • Disturbances in the pipe (bad flow profile)
Unstable/fluctuating values	<ul style="list-style-type: none"> • Air bubbles or solids in media • Bad inlet conditions

The actual velocities for the paths should be stable, constant and smoothly changing values between 0 and 10 m/s.

Technical data

10.1 SITRANS FUS080

Table 10- 1 Technical data, FUS080

Description	Specification
Enclosure design/material	Fiber glass reinforced polyamide in light-gray color
Enclosure	IP67 according to EN 60529 and DIN 40050 (NEMA 4X/6)
Wall mounting kit	Terminal box made of fiber glass reinforced polyamide in light-gray color with 2 + 2 cable glands (output, supply, and transducer cables) and a stainless steel bracket for wall or pipe mounting
Cable glands	In wall mounting kit: <ul style="list-style-type: none"> • 4 x M20 polyamide cable glands (2 for mains and output cables, 2 for the transducer coaxial cables)
Ambient temperature	-5 °C ...+60 °C (23 °F...140 °F)
Storage temperature	-40 °C...+85 °C (-40 °F...+185 °F)
Transducer / sensor cables	<ul style="list-style-type: none"> • Coaxial cable, impedance 75 Ohm, Ø app. 6mm; • Cable length: Max. 30 meter between transmitter and transducer (factory sets 15 or 30 m (49.21 or 98.43 ft))
Mechanical vibration	2 g, 1...800 Hz sinusoidal in all directions according to IEC 68-2-6
Power supply	Battery: <ul style="list-style-type: none"> • Replaceable 3.6 V LiSOCl (Lithium Thionyl Chloride) • Double battery pack 32 Ah or single back-up battery 16 Ah; • Battery change interval: 6 years at 60 °C (140 °F) operation (depending on used functions) Mains: <ul style="list-style-type: none"> • 87 ... 265 V AC (50 ... 60 Hz)
Display	<ul style="list-style-type: none"> • LCD, 8 digits, additional 2 digits and symbols for status information • Units: <ul style="list-style-type: none"> – Volume unit: m³ (default display unit) – Flow unit: m³/h (default display unit) • Alarm codes: F 1 to F 9
Push button	One push button for toggling between display information
Measuring function	<ul style="list-style-type: none"> • 0.5 Hz battery mode or <ul style="list-style-type: none"> • 15 Hz mains-powered

Description	Specification
Communication	<ul style="list-style-type: none"> • IrDA on display panel (MODBUS RTU protocol) • Optional: Separate add-on serial communication modules MODBUS RTU RS 232 or RS 485 (recommended for 230 V versions only)
Outputs (standard)	<ul style="list-style-type: none"> • Two passive, galvanically isolated open-drain MOS outputs (output A and B) • Max. ± 35 V, 50 mA • Output A: Preset to pulse output for forward flow (default: 100 l/pulse) • Output B: Preset to alarm for present failure • Pulse width: 5, 10, 20, 50, 100, 200, 500 ms (default: 5 ms) • Max. pulse frequency (for 5 ms pulse width): 100 Hz at Qmax setting (105% of Qs)
Output (option)	<ul style="list-style-type: none"> • Fieldbus communication: MODBUS RTU protocol • Separate add-on serial communication modules MODBUS RTU RS 232 or RS 485
EMC	Emission EN 61000-6-4 Immunity EN 61000-6-2
Transmitter weight	1.5 kg (3 lb)

10.2 Battery

Battery types
Replaceable 3.6 V LiSOCl (Lithium Thionyl Chloride) dual battery pack 32 Ah
Single battery 16 Ah as back-up battery for mains-powered version with back-up battery

Note

The batteries are not rechargeable; they should be replaced at least every 6 years.

Consumption and battery operation time calculation

For battery versions, the battery operation time depends on the connected battery pack as well as the operation conditions of device.

Every 5 minutes the advanced power management system of the transmitter calculates the battery consumption and the remaining battery operation time.

For battery versions, only the internal battery pack has a nominal capacity of 33 Ah giving a typical operation time of 6 years in a revenue application.

The ambient temperature of the transmitter its also influence the battery capacity.

The typical operation time of 6 years is based on only 80% battery capacity and an operation time/temperature profile of 5% at 0 °C (32 °F), 80% at 15 °C (59 °F) and 15% at 50 °C (122 °F).

The effect of other temperatures is shown in the figure below.

A variation in temperature from 15 °C to 55 °C (59 °F to 131 °F) reduces the capacity by 17% (in the figure from 15 Ah to 12½ Ah).

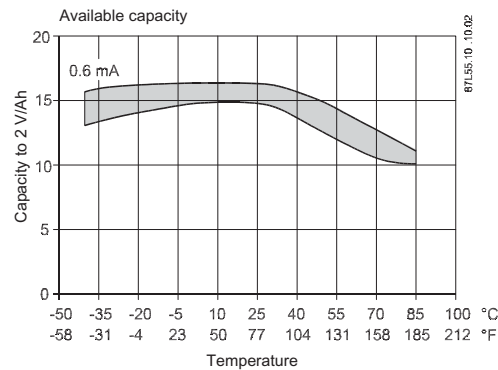

Note

The installation orientation of the battery pack may influence the battery capacity. Optimal battery capacity is achieved with the battery pack in an upright position.

10.3 Sensor geometrical data

In order to ensure maximum measurement accuracy, precise sensor-specific data are required.

Data	Sensor size	Required accuracy
Path angle	DN 100-1200 (8" – 48")	0.1°
• Transducer and path distances	DN 100-400 (8" – 32")	0.2 mm
• Outer pipe diameter	DN 400-1000 (32" – 48")	0.8 mm
• Pipe wall thickness	DN 1000-1200 (40" – 48")	2.0 mm

Proper use of the measurement report normally ensures that measured values come very close to the nominal dimensions listed in the appendix "Settings" "Dimension dependent settings", SONOKIT 2-path and "Dimension dependent settings", SONOKIT 1-path

Note

Sensor recalibration

If measured and nominal values differ more than allowed, please re-configure/re-calibrate the flowmeter in the field.

10.4 Dimensions

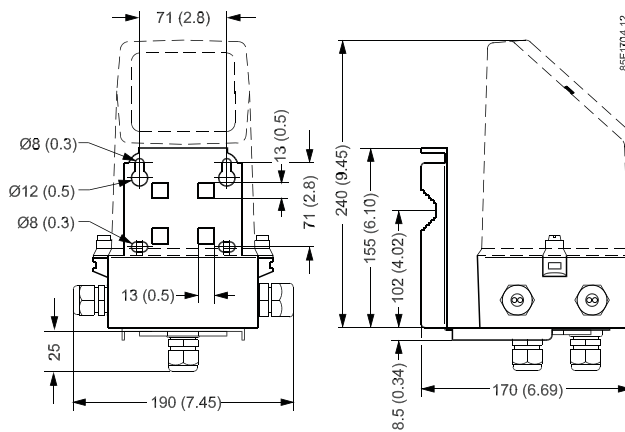

SIEMENS

Qualification Certificate **SITRANS F FUS/E080 based flowmeter**

<p><u>Totalizer values</u></p> <p>Totalizer 1: 0,4444444 m3 Totalizer 2: 0 m3 Customer Totalizer 3: 0,4444444 m3</p> <p>Customer Totalizer 3 reset: 18-03-2011 10:18:08</p> <p>Customer Totalizer 3 reset done: (Date and signature) <input type="checkbox"/> Yes <input type="checkbox"/> No <input style="width: 150px;" type="text"/></p>	<p><u>Power Supply Status</u></p> <p>Power supply: Battery only Battery installation date: 18-03-2011 10:06:04 Battery consumed power: 2,049692 Ah Battery capacity: 25 Ah (12.5 Ah single bat. or 25 Ah double pack bat.) Battery alarm limit: 80 per cent</p> <p>Battery change and capacity calculation reset done: (Date and signature) <input type="checkbox"/> Yes <input type="checkbox"/> No <input style="width: 150px;" type="text"/></p>
<p><u>Transmitter output A (pulse output)</u></p> <p>Output enable: Yes Pulse direction: Forward Amount per pulse: 1 m3 Pulse width: 5 ms</p> <p>Amount per pulse: _____ m3 (transmitter label) Pulse width: _____ ms (transmitter label)</p> <p>The PDM- and label must be the same: Passed : (Date and signature) <input type="checkbox"/> Yes <input type="checkbox"/> No <input style="width: 150px;" type="text"/></p>	<p><u>Transmitter output B</u></p> <p>Output enable: Yes Output function: Alarm Pulse direction: (pulse function only) Amount per pulse: (pulse function only) Pulse width: (pulse function only)</p> <p>Amount per pulse: _____ m3 (transmitter label) Pulse width: _____ ms (transmitter label)</p> <p>The PDM- and label must be the same: Passed : (Date and signature) <input type="checkbox"/> Yes <input type="checkbox"/> No <input style="width: 150px;" type="text"/></p>
<p><u>Measurement Function, Operation and Diagnostic:</u></p> <p>Flow rate: 0 m3/h Flow rate: _____ m3/h (transm. display) Relative flow rate: 0 per cent of Qmax (must be below 100)</p> <p>Actual velocity track 1: 0 m/s Actual velocity track 2: 0 m/s (values must be the same for both tracks, +/- 0.05 m/s ok)</p> <p>Track 1 gain step: 15 Track 2 gain step: 15 (values must be the same for both tracks, +/- 1 ok) (good between 1 – 8, typical 3 – 5, depends on pipe size. If > 8, then it is not ok and max. bad value is 15)</p> <p>Passed : (Date and signature) <input type="checkbox"/> Yes <input type="checkbox"/> No <input style="width: 150px;" type="text"/></p>	<p><u>Faults / Alarms</u></p> <p>Transmitter fault status: Faults: 1 2</p> <p>Alarm / faults or warnings on the display?: <input type="checkbox"/> Yes <input type="checkbox"/> No</p> <p>If yes, which are shown: <input type="checkbox"/>F1 <input type="checkbox"/>F2 <input type="checkbox"/>F3 <input type="checkbox"/>F4 <input type="checkbox"/>F5 <input type="checkbox"/>F6 <input type="checkbox"/>F7 <input type="checkbox"/>F8 <input type="checkbox"/>F9</p> <p>Passed : (Date and signature) <input type="checkbox"/> Yes <input type="checkbox"/> No <input style="width: 150px;" type="text"/></p>

Figure 11-2 Qualification certificate (page 2)

SIEMENS

Qualification Certificate SITRANS F FUS/E080 based flowmeter

<p><u>Service / Diagnostic</u></p> <p>Fixed flow mode enable: No Fixed flow value: 100 m³/h (max. allowed value is Q_{max} = 399 m³/h)</p> <p>Output A controlling Auto Output B controlling Auto</p> <p>Check: The fixed flow must be 'No' and outputs 'Auto'.</p> <p>Passed : (Date and signature) <input type="checkbox"/> Yes <input type="checkbox"/> No <input style="width: 150px; height: 15px;" type="text"/></p>	
------------------------------------------------------------------------------------------------------------------------------------------------------------------------------------------------------------------------------------------------------------------------------------------------------------------------------------------------------------------------------------------------------------------------------------------------------------------------------------------------------------------------------------------------------------------	--

<p><u>Comments</u></p> <hr/> <hr/> <hr/> <hr/>

Complete Qualification Passed: Yes No

The values were verified of (name) _____

Date and signature _____

Figure 11-3 Qualification certificate (page 3)

Parameter lists

The following tables show the various parameters available via PDM.

The parameters are accessible at three different levels:

- Read: Maintenance level
- Read/Write (R/W): Specialist level (write access is only permitted after entering the user password; default password is 1000)
- Hardware locked (HW key): The parameter is only accessible when a HW key is mounted

A.1 Identification

Table A- 1 Identification parameters (FW 2.03 and EDD 1.02.07-01)

Modbus Address	Parameter		Default value	Value range	Access level	Description
40049	1	Application identifier	Identity		R/W	Customer application identification information (max 16 characters)
40057	2	Application location	Location		R/W	Customer application location information (max 16 characters)
Device						
40032	5	Sensor size	Product dependent	See "Dimension dependent settings", SONOKIT 2-path and "Dimension dependent settings", SONOKIT 1-path	R/W	Pipe diameter of the sensor. It is only a text field for measurement system information. The value has no influence on the measurement. Please see inner diameter at pipe date in parameter 306
40141	8	Totalizer unit	m ³	See "unit conversion table"	R/W	Totalizer unit as text for volume. Change the unit in parameter table if the device menu 'Unit guide (offline)' does not list the wanted unit. Note: The device display can show 'm3' unit only - other units cannot be shown on the display, but will be used and shown online via PDM

Parameter lists

A.1 Identification

Modbus Address	Parameter		Default value	Value range	Access level	Description
40135	9	Flowrate unit	m ³ /h	see appendix A6	R/W	Flow unit as text for actual flowrate. Change the unit in parameter table if the device menu 'Unit guide (offline)' does not list the wanted unit. Note: The device display can show 'm3/s' unit only - other units cannot be shown on the display, but will be used and shown online via PDM.
40129	10	Maximum flow	Qmax	See "Dimension dependent settings", SONOKIT 2-path and "Dimension dependent settings", SONOKIT 1-path	R/W	Maximum flow
40162	373	Low flow cut-off	0.25	0 ... 10	R/W	If the flow comes below this percentage of Qmax, then the flow value is set to zero
40008	20	Vendor name	Siemens A/S		Read	Siemens A/S Flow Instruments, Denmark
40001	21	Module type	11	0 ... 14	Read	Type of flowmeter
40002	22	Software version	2.03			Software version of the flowmeter
40022	23	Product code number	Product dependent			Siemens production sales code number (the first part of the system number on the nameplate)
40014	24	System Serial number	Product dependent		R/W	Siemens production number (the second part of the system number on the nameplate)
40065	25	Transmitter serial number	Product dependent		HW key	Serial number of the electronics
40073	26	Sensor serial number	Product dependent			Serial number of the sensor
40162	373	Low flow cut-off	0.25	0 ... 10	R/W	If the flow comes below this percentage of Qmax, then the flow value is set to zero

A.2 Output

Table A- 2 Output parameters

Modbus Address	Parameter		Default value	Value range	Access level	Description
43023	100	Actual date and time	Product dependent		R/W	Actual date and time (day-month-year and hours:minutes:seconds)
43006	101	Totalizer 1	0	-2000000001 ... +2000000001	Read	Volume for totalization register 1
43010	102	Totalizer 2	0	-2000000001 ... +2000000001	Read	Volume for totalization register 2
43014	103	Customer totalizer 3	0		Read	Customer totalizer 3 based on totalizer 1 set up
19	104	Reset customer totalizer 3	No	No, Yes	R/W	Reset of customer totalizer
40732	105	Customer totalizer 3 reset date	last reset date	dd-mm-yyyy, hh:mm:ss		Date and time when customer totalizer has been reset
43001	106	Flow rate			Read	Actual flow value
43136	107	Relative flow rate	0		Read	Actual flow value in relation to Qmax
43035	108	Actual velocity for path 1	0		Read	The actual flow velocity for path 1 in m/s (SI-unit)
43046	109	Actual velocity for path 2	0			The actual flow velocity for path 2 in m/s (SI-unit). Valid for 2-path solutions only
43026	110	Path 1 gain step	15	1 to 15	Read	Amplifier setting when measuring path 1
43037	111	Path 2 gain step	15	1 to 15	Read	Amplifier setting when measuring path 2. Valid for 2-path solutions only
Pulse A B						
40817	430	Output A enable	Yes	No, Yes	R/W	Select 'Yes' to enable output A
40818	431	Pulse A function	Forward	Forward, Reverse, Forward net, Reverse net	R/W	Pulse output calculation on pure forward flow or pure reverse flow - or net flow for forward and reverse pulse flow. Valid if pulse output A is enabled
40819	432	Amount per pulse A	1.000000 (m ³)	0.000001 ... 1000000000	R/W	Volume per pulse and selected unit Valid if pulse output A is enabled.
40821	433	Pulse width for pulse A	5 ms	5, 10, 20, 50, 100, 200, 500 ms	R/W	Pulse length when the pulse is active. Valid if pulse output A is enabled
40822	440	Output B enable	Yes	No, Yes	R/W	Select 'Yes' to enable output B
40823	441	Pulse B function	Alarm	Pulse, Alarm, Call up	R/W	Configuration of output B as pulse - alarm or call up function. Valid if pulse output B is enabled

Parameter lists

A.2 Output

Modbus Address	Parameter	Default value	Value range	Access level	Description
40824	442 Pulse B direction	Reverse	Forward, Reverse, Forward net, Reverse net.	R/W	Pulse output calculation on pure forward flow or pure reverse flow - or net flow for forward and reverse pulse flow. Valid if pulse output B is enabled and pulse function selected
40825	443 Amount per pulse B	1.000000 (m ³)	0.000001 ... 1000000000	R/W	Volume per pulse. Valid if pulse output B is enabled and pulse function selected
40827	444 Pulse width for pulse B	5 ms	5, 10, 20, 50, 100, 200, 500 ms	R/W	Pulse length when the pulse is active. Valid if pulse output B is enabled and pulse function selected
Communication					
For editing the communication settings, use PDM device menu "Communication Setting"					
40833	591 Device Communication Address	1	1 ... 247	Read	Meter has default address value 1 with selectable address up to 247
40834	592 Baudrate	4	0 ... 5	Read	Communication port speed
40835	593 Parity	0	0 ... 3	Read	Communication port parity
40836	594 Interframe space	35	35 ... 255	Read	Minimum space between two messages (bytes x 10)
40837	595 Response delay	5	1 ... 50	Read	Minimum time from receiving a request to its response
Data logger					
40619	600 Log interval	Monthly	Daily, Weekly, Monthly	R/W	Log interval
40620	601 Day of week, if weekly log	Sunday	Monday to Sunday	R/W	When log interval is set to weekly logging, this parameter defines what weekday the logging is performed. Valid if weekly log interval is activated
40621	602 Limit for too high consumption	1E+09	-3.4E+38 ... +3.4E+38	R/W	Limit for too low consumption during current log interval. Based on totalizer 1 and the selected unit
40623	603 Limit for too low consumption	No	-3.4E+38 ... +3.4E+38	R/W	Limit for too low consumption during current log interval. Based on totalizer 1 and the selected unit
22	604 Reset log		No, Yes	HW key	Reset data logger
Periodic log Totalizer 1					
40770	160 Next settling date	01-01-2000	dd-mm-yyyy	R/W	Next settling date where actual value of totalizer 1 is stored
40773	161 Latest settling date	01-01-2000	dd-mm-yyyy	Read	Latest settling date where value of totalizer 1 was stored
40776	162 Latest totalizer 1 value	0		Read	Latest stored value of totalizer 1

Modbus Address	Parameter	Default value	Value range	Access level	Description
40780	163 Previous settling date	01-01-2000		Read	Previous settling date where value of totalizer 1 was stored
40783	164 Previous totalizer 1 value	0	dd-mm-yyyy	Read	Previously stored value of totalizer 1

A.3 Diagnostic

Table A- 3 Diagnostic

Modbus Address	Parameter	Default value	Value range	Access level	Description
	Diagnostic				
40804	500 Latest service date	01-01-2000	dd-mm-yyyy	R/W*	Latest service date (can also be used for date of installation)
40808	501 Operating hours since power up	0	3.4E+38 h	Read	Total operation hours since last power up
40807	503 Numbers of power up	0	0 ... 65535	Read	Total number of power-ups since first power-up.
Alarm					
43005	200 Fault status		One or more of the following values: 1, 2, 3, 4, ... up to 16	Read	Fault status 1: Path 1 error 2: Path 2 error 3: Dual slope calibration error 4: Database checksum error 5: Low power warning 6: Flow overload warning 7: Pulse A overload warning 8: Pulse B overload warning 9: Consumption interval error 10: Not used 11: Not used 12: Not used 13: Not used 14: Not used 15: Not used 16: Not used
40346	202 Date of fault log reset	Last reset date	dd-mm-yyyy, hh:mm:ss	Read	Date of last fault log reset
14	204 Reset the fault log and faults	No	No, Yes	R/W	Reset the fault log and faults
15	205 Call up acknowledge	No	No, Yes	R/W	Select 'Yes' to reset active call-up

Parameter lists

A.3 Diagnostic

Modbus Address	Parameter		Default value	Value range	Access level	Description
21	209	Reset consumption log fault	No	No, Yes	R/W	Reset the consumption fault. Caused by too low or too high consumption in the log interval
3	210	Path 1 alarm output enable	Yes	No, Yes	R/W	Select 'Yes' to enable current alarm on alarm output / call-up
	211	Path 1 fault hours	e.g. 36 h	Read;		Total hours fault active
40258	212	Path 1 fault counter	e.g. 4	0 ... 65535	Read	Total number of faults. Valid only if alarm is enabled
40259	213	Path 1 fault appears	Last fault appear date	dd-mm-yyyy, hh:mm:ss	Read	Last time the fault appeared. Valid only if alarm is enabled
40262	214	Path 1 fault disappears	Last fault disappear date	dd-mm-yyyy, hh:mm:ss	Read	Last time the fault disappeared. Valid only if alarm is enabled
4	215	Path 2 alarm output enable	Yes	No, Yes	R/W	Select 'Yes' to enable active alarm on alarm output / call-up. Valid only for 2-path solutions
40265	216	Path 2 fault hours	e.g. 36 h	Read;	Read	Total hours fault active. Valid only for 2-path solutions and if alarm is enabled
40266	217	Path 2 fault counter	e.g. 4	0 ... 65535	Read	Total number of faults. Valid only for 2-path solutions and if alarm is enabled
40267	218	Path 2 fault appears	Last fault appear date	dd-mm-yyyy, hh:mm:ss	Read	First time the fault appeared. Valid only for 2-path solutions and if alarm is enabled
40270	219	Path 2 fault disappears	Last fault disappear date	dd-mm-yyyy, hh:mm:ss	Read	Last time the fault disappeared. Valid only for 2-path solutions and if alarm is enabled
5	220	Dual slope alarm output enable	Yes	No, Yes	R/W	Select 'Yes' to enable active alarm on alarm output / call-up
40273	221	Dual slope fault hours	e.g. 0 h	0 ... 65535	Read	Total hours fault active. Valid only if alarm is enabled
40274	222	Dual slope fault counter	e.g. 0	0 ... 65535	Read	Total number of faults. Valid only if alarm is enabled
40275	223	Dual slope fault appears	e.g. 0 h	0 ... 65535	Read	First time the fault appeared. Valid only if alarm is enabled
40278	224	Dual slope fault disappears	e.g. 0	0 ... 65535	Read	Last time the fault disappeared. Valid only if alarm is enabled
6	225	Parameter checksum alarm output enable	Yes	No, Yes	R/W	Select 'Yes' to enable active alarm on alarm output / call-up
40281	226	Parameter checksum fault hours	e.g. 0 h	0 ... 65535	Read	Total hours fault active. Valid only if alarm is enabled
40282	227	Parameter checksum fault counter	e.g. 0	0 ... 65535	Read	Total number of faults. Valid only if alarm is enabled

Modbus Address	Parameter	Default value	Value range	Access level	Description	
40283	228	Parameter checksum fault appears	e.g. 0 h	0 ... 65535	Read	First time the fault appeared. Valid only if alarm is enabled
40286	229	Parameter checksum fault disappears	e.g. 0	0 ... 65535	Read	Password to change parameters in the flowmeter. Valid only if alarm is enabled
7	230	Low power alarm output enable	Yes	No, Yes	R/W	Select 'Yes' to enable active alarm on alarm output / call-up
40289	231	Low power fault hours	e.g. 0 h	0 ... 65535	Read	Total hours fault active. Valid only if alarm is enabled
40290	232	Low power fault counter	e.g. 0	0 ... 65535	Read	Total number of faults. Valid only if alarm is enabled
40291	233	Low power fault appears	e.g. 0 h	0 ... 65535	Read	First time the fault appeared. Valid only if alarm is enabled
40294	234	Low power fault disappears	e.g. 0	0 ... 65535	Read	Last time the fault disappeared. Valid only if alarm is enabled
8	235	Flow overflow alarm output enable	Yes	No, Yes	R/W	Select 'Yes' to enable active alarm on alarm output / call-up
40297	236	Overflow fault hours	e.g. 0 h	0 ... 65535	Read	Total hours fault active. Valid only if alarm is enabled
40298	237	Overflow fault counter	e.g. 0	0 ... 65535	Read	Total number of faults. Valid only if alarm is enabled
40299	238	Overflow fault appears	e.g. 0 h	0 ... 65535	Read	First time the fault appeared. Valid only if alarm is enabled
40302	239	Overflow fault disappears	e.g. 0	0 ... 65535	Read	Last time the fault disappeared. Valid only if alarm is enabled
9	240	Pulse A overload alarm output enable	Yes	No, Yes	R/W	Select 'Yes' to enable active alarm on alarm output / call-up
40305	241	Pulse A overload fault hours	e.g. 0 h	0 ... 65535	Read	Total hours fault active. Valid only if alarm is enabled
40306	242	Pulse A overload fault counter	e.g. 0	0 ... 65535	Read	Total number of faults. Valid only if alarm is enabled
40307	243	Pulse A overload fault appears	e.g. 0 h	0 ... 65535	Read	First time the fault appeared. Valid only if alarm is enabled
40310	244	Pulse A overload fault disappears	e.g. 0	0 ... 65535	Read	Last time the fault disappeared. Valid only if alarm is enabled
10	245	Pulse B overload alarm output enable	Yes	No, Yes	R/W	Select 'Yes' to enable active alarm on alarm output / call-up
40313	246	Pulse B overload fault hours	e.g. 0 h	0 ... 65535	Read	Total hours fault active. Valid only if alarm is enabled
40314	247	Pulse B overload fault counter	e.g. 0	0 ... 65535	Read	Total number of faults. Valid only if alarm is enabled
40315	248	Pulse B overload fault appears	e.g. 0 h	0 ... 65535	Read	First time the fault appeared. Valid only if alarm is enabled

Modbus Address	Parameter		Default value	Value range	Access level	Description
40318	249	Pulse B overload fault disappears	e.g. 0	0 ... 65535	Read	Last time the fault disappeared. Valid only if alarm is enabled
11	250	Consumption alarm output enable	Yes	No, Yes	R/W	Select 'Yes' to enable active alarm on alarm output / call-up
40321	251	Consumption fault hours	e.g. 0 h	0 ... 65535	Read	Total hours fault active. Valid only if alarm is enabled
40322	252	Consumption fault counter	e.g. 0	0 ... 65535	Read	Total number of faults. Valid only if alarm is enabled
40323	253	Consumption fault appears	e.g. 0 h	0 ... 65535	Read	First time the fault appeared. Valid only if alarm is enabled
40326	254	Consumption fault disappears	e.g. 0	0 ... 65535	Read	Last time the fault disappeared. Valid only if alarm is enabled
12*	255	Leakage alarm output enable	Yes	No, Yes	R/W	Select 'Yes' to enable active alarm on alarm output / call-up
40329	256	Leakage fault hours	e.g. 0 h	0 ... 65535	Read	Total hours fault active. Valid only if alarm is enabled
40330	257	Leakage fault counter	e.g. 0	0 ... 65535	Read	Total number of faults. Valid only if alarm is enabled
40331	258	Leakage fault appears	e.g. 0 h	0 ... 65535	Read	First time the fault appeared. Valid only if alarm is enabled
40334	259	Leakage fault disappears	e.g. 0	0 ... 65535	Read	Last time the fault disappeared. Valid only if alarm is enabled
13*	260	Empty pipe alarm output enable	Yes	No, Yes	R/W	Select 'Yes' to enable active alarm on alarm output / call-up
40337	261	Empty pipe fault timer	e.g. 0 h	0 ... 65535	Read	Total hours fault active. Valid only if alarm is enabled
40338	262	Empty pipe fault counter	e.g. 0	0 ... 65535	Read	Total number of faults. Valid only if alarm is enabled
40339	263	Empty pipe fault appears	e.g. 0 h	0 ... 65535	Read	First time the fault appeared. Valid only if alarm is enabled
40342	264	Empty pipe fault disappears	e.g. 0	0 ... 65535	Read	Last time the fault disappeared. Valid only if alarm is enabled
Service						
17	510	Fixed flow mode enable	Yes	No, Yes	R/W	Select 'Yes' to force the device to show a fixed flow value Default must be "No" Always manually reset the value to "No"
40801	511	Fixed flow value	0	-1E+09 ... 1E+09	R/W	Fixed flow value for enabled fixed flow

Modbus Address	Parameter		Default value	Value range	Access level	Description
40803	515	Controlling output A and B	Auto	Auto, Forced	HW key	Control of output A and B is used to stop or force the output A and/or B. For editing, use device menu 'Service'. Valid if pulse output is enabled
Power						
43120	130	Consumed battery capacity	e.g. 2.054239 Ah		Read	The amount of energy consumed since last time the battery was replaced. Valid only for battery-powered versions
40808	501	Operating hours since power up	1105 h	3.4 E+38	Read	Total operation hours since first power up
40807	503	Numbers of power up	e.g. 4	0 ... 65535	Read	Total number of power-ups since first power-up.
18	540	Battery change enable	No	No, Yes	R/W	Select 'Yes' to set battery installation date to current date and reset remaining battery operation capacity to maximum. Valid only for battery-powered versions
40881	541	Battery installation date	last battery installation date	dd-mm-yyyy; hh:mm:ss	Read	Latest installation date of batteries. Valid only for battery-powered versions
40880	542	Power supply mode	Battery only	Battery only, Mains only, Mains with backup battery.	Read	The flowmeter is either powered by battery only, mains only or by mains with battery backup. The type is defined by the order code and cannot be changed.
40849	543	Actual battery capacity	25.000000	0 ... 50	R/W**	The capacity of the battery in Ah - Single 12.5 Ah - Dual battery pack 25.0 Ah Valid only for battery-powered versions
40851	544	Battery alarm limit	80	0 ... 90	R/W	Present an alarm when the consumed energy superceeds this percentage of the battery capacity. Valid only for battery-powered versions

* Not supported for FUS080

** Maintenance = Read only

A.4 Meter setup

Table A- 4 Meter setup parameters

Modbus Address	Parameter	Default value	Value range	Access level	Description	
Meter Setup						
40179	307	Flow velocity offset	0 m/s	-10 ... 10 m/s	HW key	Velocity added to measured flow velocity
40182	310	Calibration factor	1.0	0 ... 2	R/W	This calibration factor will be calculated at the factory with wet-calibration. For FUS080-SONOKIT (retrofit) installations this parameter should be calculated by the pipe geometric tool (see 'Pipe geo. assistant' in 'Device' menu)
40151	311	Adjustment Factor	1	- 2 ... 2	R/W	Meter correction factor for customer adjustment of the calculated flow value. Can be used at installations where a reference meter is used to get reference to the true flow rate
40196	312	Transducer cable length	Product dependent	0 ... 200 m	R/W	Cable length (m) from sensor to transmitter
40173	372	Filter time constant	Product dependent	0 ... 100 s	R/W	General time filter for flow measurement. Filter constant is the time that must pass before the filter's output value is at 70% of the change of its input value. Higher number gives a slower and more stable flow signal.
40184	380	Protect linearization from user access.	No	No, Yes	Read	Protection of the linearization parameters. It is decided by the order number and cannot be changed. The linearization parameters are listed in the device menu 'Linearization'
Totalizer						
40673	400	Flow direction totalizer 1	Forward	Forward, Reverse, Net	R/W	Calculation principle on flow direction for forward, reverse or net flow
40675	401	Totalizer 1 change date	Last change date	dd-mm-yyyy; hh:mm:ss	Read	Date and time when totalizer 1 function was changed
40674	410	Flow direction totalizer 2	Reverse	Forward, Reverse, Net	R/W	Calculation principle on flow direction for forward - reverse or net flow
40678	411	Totalizer 2 change date	Last change date	dd-mm-yyyy; hh:mm:ss	Read	Date and time when totalizer 2 function was changed

Modbus Address	Parameter	Default value	Value range	Access level	Description	
Pipe data						
40181	300	Number of paths	Product dependent	2	R/W	Number of paths on the sensor
40149	302	Max sample frequency	15	15	Read	The maximum frequency for flow measurement
40147	303	Sample frequency	0.5	15	HW key	The frequency at which the flow is measured
40167	304	Rn for path 1	Product dependent	3.4E+38 m	Read	R-factor for path 1. For FUS080/SONOKIT (retrofit) installations this parameter will automatically be calculated by the pipe geometric tool (see 'Pipe geo. assistant' in 'Device' menu).
40169	305	Rn for path 2	Product dependent	3.4E+38 m	Read	R-factor for path 2. For FUS080/SONOKIT (retrofit) installations this parameter will automatically be calculated by the pipe geometric tool (see 'Pipe geo. assistant' in 'Device' menu). Valid only for 2-path solutions
40171	306	Inner pipe diameter	Product dependent	0.05 ... 1.200 m	Read	Inner pipe diameter in meters. For FUS080/SONOKIT (retrofit) installations this parameter will automatically be calculated by the pipe geometric tool (see 'Pipe geo. assistant' in 'Device' menu).

A.5 Human Interface

Table A- 5 Human Interface parameters

Modbus Address	Parameter		Default value	Value range	Access level	Description
40757	420	Decimal point	Automatic point adjust	No point; One digit after point; Two digits after point; Three digits after point; Automatic point adjust.	R/W	Decimal numbers for displayed totalized value
40753	422	Operator Menu 1	All	1 to 5	Read only	Menu setup 1. Totalizer 1 2. Totalizer 2 3. Actual flow rate 4. Error menu 5. Display test menu For editing, use device menu 'Human Interface'

A.6 Unit conversion table

The following tables show examples of totalizer and flow rate units. More are available via SIMATIC PDM tool

Table A- 6 Totalizer units

Unit	Correction factor
Default	1 m ³
m ³ *100	0.01
Gallon (US)	264.1721
G*100 (100*Gallon)	2.641721
G*1000 (1000*Gallon)	0.2641721
MG (1000000*Gallon)	0.0002641721
AI (Acre Inches)	0.009728558
AF (Acre ft)	0.0008107132
CF*100 (100*ft ³)	0.3531467
CF*1000 (1000*ft ³)	0.03531467
l*100 (liter)	10
kl (1000*liter)	1
MI (Mega liter)	0.001

Table A- 7 Flow rate units

Flow rate	Correction factor parameter
Default	1 m ³ /s
m ³ /min (m ³ /minute)	60
m ³ /h (m ³ /hour)	3600
m ³ /d (m ³ /day)	86400
GPS (Gallon/second)	264.1721
GPM (Gallon/minute)	15850.32
GPH (Gallon/hour)	951019.4
GPD (Gallon/day)	22824465
MGPD (1000000*Gallon/day)	22.824465
CFS (ft ³ /second)	35.31467
CFM (ft ³ /minute)	2118.882
CFH (ft ³ /hour)	127132.8
l/s (liter/second)	1000
l/min (liter/minute)	60000
l/h (liter/hour)	3600000
MI/d (1000000lLiter/day)	86.4

Settings

B.1 Factory settings

The FUS080/SONOKIT is from factory configured according to the order specification.

For the calibration / configuration of the flowmeter the application specific pipe **dimensions** and the specific transducer locations are used.

Table B- 1 Factory settings

Identification	1-path factory settings (DN (100 to DN 1200))	2-path factory settings DN (DN 200 to DN 1200)	Possible settings
Meter identification	-	-	Free text 15 characters
Application location	-	-	Free text 15 characters
Display menu	Menu 1- 5 (all)	Menu 1 – 5 (all)	Menu 1 – 5, min one of the five
Pipe data			
Number of paths	1	2	1 or 2
Inner pipe diameter (m)	See "Dimension dependent settings"	See "Dimension dependent settings"	Input to pipe geometry program
Transducer distance (m)	See "Dimension dependent settings"	See "Dimension dependent settings"	Input to pipe geometry program
Distance between sound paths, path displacement (m)	See "Dimension dependent settings"	See "Dimension dependent settings"	Input to pipe geometry program
Path angle (°)	See "Dimension dependent settings"	See "Dimension dependent settings"	Input to pipe geometry program
Q max	See "Dimension dependent settings"	See "Dimension dependent settings"	Adjustable
Low flow cut-off (% of Qmax)	0.25 %	0.25 %	0 ... 10%
Fliter time constant	5 s	5 s	5 ... 1000 s
Geometry factor path 1	See "Dimension dependent settings"	See "Dimension dependent settings"	Auto set from pipe geometry help program in PDM
Geometry factor path 2	-	See "Dimension dependent settings"	Auto set from pipe geometry help program in PDM
Correction factor			
Costumer correction factor	1	1	0.5 ... 1.5
Measuring unit and factors			
Flow unit factor	3600	3600	Auto set from unit guide
Totalizer volume unit factor	1	1	Auto set from unit guide
Flow unit text	m ³ /h	m ³ /h	Auto set from unit guide, but only m ³ /h can be shown on display
Totalizer unit text	m ³	m ³	Auto set from unit guide, but only m ³ can be shown on display

Settings

B.2 Factory settings for MODBUS communication

Totalizer directions			
Totalizer 1 direction	Forward	Forward	Forward/Reverse/Forward net/Reverse net
Totalizer 2 direction	Reverse	Reverse	Forward/Reverse/Forward net/Reverse net
Digital output 1			
Active	On	On	On/off
Direction	Forward	Forward	Forward/Reverse/Forward net/Reverse net
Amount per pulse	0.1m ³	0.1 m ³	Unit: The same as Totalizer unit Value freely selectable
Pulse width	5 ms	5 ms	5, 10, 20, 50, 100, 200, 500 ms
Digital Output 2			
Active	On	On	On/off
Function	Alarm	Alarm	Pulse/Alarm/Call up
Direction	No influence, while "Alarm"	No influence, while "Alarm"	Forward/Reverse/Forward net/Reverse net
Amount per pulse	No influence, while "Alarm"	No influence, while "Alarm"	Unit: The same as Totalizer unit Value freely selectable
Pulse width	No influence, while "Alarm"	No influence, while "Alarm"	5, 10, 20, 50, 100, 200, 500 ms

B.2 Factory settings for MODBUS communication

Parameter	Default setting
Slave device address	1
Data transmission rate	19 200
Vertical parity position	E-8-1 (0 - even)
Response timeout	10000 ms
Response delay	1 ms
Interframe space	35

The settings can be changed via SIMATIC PDM or via the MODBUS.

B.3 Measurement report, SONOKIT 2-path

Sensor geometry measurement report

Company		Name		Approved by	
Date		Sensor size		Pressure (PN)	
				Tag no.:	
Note					
→ = Flow direction					
Measure		Calculation		Result	
Circumference (C)		$C / \pi = \text{Outer diameter of the pipe } (D_u)$		D_u	
Pipe wall thickness (t)		$D_u - (2 \times t) = \text{Internal diameter } (D_i)$		D_i	
Transducer distance (L) path 1			$L_1 =$		
Transducer distance (L) path 2			$L_2 =$		
Angle θ transducer 1A (angle 1A = 1B ; +/- 0,1°)			Average angle (path 1) "(1A + 1B) / 2"		
Angle θ transducer 1B (angle 1A = 1B ; +/- 0,1°)					
Angle θ transducer 2A (angle 2A = 2B ; +/- 0,1°)			Average angle (path 2) "(2A + 2B) / 2"		
Angle θ transducer 2B (angle 2A = 2B ; +/- 0,1°)					
Transducer separation H_a			$h = (H_a + H_b) / 4$ (for FUS060) and $H = 2 \times h$ (for FUS080)		
Transducer separation H_b					
Cable length (distance from transducer to converter x 2)			Q_{max}		

B.4 Dimension dependent settings, SONOKIT 2-path

Nominal size *)		Max. vol. flow [m ³ /h]	Pipe diameter [m]	Path displacement [m]	Path 1 angle [°]	Path 1 length [m]	Path 2 angle [°]	Path 2 length [m]
[mm]	[inch]							
DN 200	8	380	0.2083	0.0510	60	0.2257	60	0.2257
DN 250	10	600	0.2604	0.0638	60	0.2782	60	0.2782
DN 300	12	850	0.3098	0.0759	60	0.3279	60	0.3279
DN 350	14	1000	0.3396	0.0832	60	0.3579	60	0.3579
DN 400	16	1300	0.3904	0.0956	60	0.4090	60	0.4090
DN 450	18	1700	0.4500	0.1103	60	0.4690	60	0.4690
DN 500	20	2200	0.4920	0.1205	60	0.5113	60	0.5113
DN 550	22	2600	0.5500	0.1348	60	0.5697	60	0.5697
DN 600	24	3200	0.6016	0.1474	60	0.6216	60	0.6216
DN 650	26	3600	0.6500	0.1593	60	0.6704	60	0.6704
DN 700	28	4200	0.6952	0.1703	60	0.7159	60	0.7159
DN 750	30	4800	0.7500	0.1838	60	0.7710	60	0.7710
DN 800	32	5500	0.7968	0.1952	60	0.8181	60	0.8181
DN 900	36	7500	0.9100	0.2230	60	0.9321	60	0.9321
DN 1000	40	9000	1.0000	0.2450	60	1.0227	60	1.0227
DN 1100	44	10000	1.1000	0.2695	60	1.1233	60	1.1233
DN 1200	48	13200	1.2000	0.2940	60	1.2240	60	1.2240
DN 1300	52	14000	1.3000	0.3185	60	1.3246	60	1.3246
DN 1400	56	16800	1.4000	0.3430	60	1.4253	60	1.4253
DN 1500	60	19000	1.5000	0.3675	60	1.5259	60	1.5259
DN 1600	64	22800	1.6000	0.3920	60	1.6266	60	1.6266
DN 1700	68	25000	1.7000	0.4165	60	1.7273	60	1.7273
DN 1800	72	27600	1.8000	0.4410	60	1.8279	60	1.8279
DN 1900	76	31000	1.9000	0.4655	60	1.9286	60	1.9286
DN 2000	80	36000	2.0000	0.4900	60	2.0292	60	2.0292
DN 2100	84	37000	2.1000	0.5145	60	2.1299	60	2.1299
DN 2200	88	42000	2.2000	0.5390	60	2.2306	60	2.2306
DN 2300	92	45000	2.3000	0.5635	60	2.3312	60	2.3312
DN 2400	96	51000	2.4000	0.5880	60	2.4319	60	2.4319
DN 2500	100	53000	2.5000	0.6125	60	2.5325	60	2.5325
DN 2600	104	60000	2.6000	0.6370	60	2.6332	60	2.6332
DN 2700	108	62000	2.7000	0.6615	60	2.7338	60	2.7338
DN 2800	112	72000	2.8000	0.6860	60	2.8345	60	2.8345
DN 2900	116	71000	2.9000	0.7105	60	2.9352	60	2.9352
DN 3000	120	78000	3.0000	0.7350	60	3.0358	60	3.0358
DN 3100	124	82000	3.1000	0.7595	60	3.1365	60	3.1365
DN 3200	128	85000	3.2000	0.7840	60	3.2371	60	3.2371

Nominal size *)		Max. vol. flow [m ³ /h]	Pipe diameter [m]	Path displacement [m]	Path 1 angle [°]	Path 1 length [m]	Path 2 angle [°]	Path 2 length [m]
[mm]	[inch]							
DN 3300	132	92000	3.3000	0.8085	60	3.3378	60	3.3378
DN 3400	136	100000	3.4000	0.8330	60	3.4384	60	3.4384
DN 3500	140	100000	3.5000	0.8575	60	3.5391	60	3.5391
DN 3600	144	110000	3.6000	0.8820	60	3.6398	60	3.6398
DN 3700	148	120000	3.7000	0.9065	60	3.7404	60	3.7404
DN 3800	152	130000	3.8000	0.9310	60	3.8411	60	3.8411
DN 3900	156	130000	3.9000	0.9555	60	3.9417	60	3.9417
DN 4000	160	144000	4.0000	0.9800	60	4.0424	60	4.0424

*) For FUS080 transmitter based systems only up to DN1200

B.5 Measurement report, SONOKIT 1-path

Sensor geometry measurement report

Company		Name		Approved by	
Date		Sensor size		Pressure (PN)	
				Tag no.:	
Note					
→ = Flow direction					
Measure		Calculation		Result	
Circumference (C)		$C / \pi = \text{Outer diameter of the pipe } (D_u)$		D_u	
Pipe wall thickness (t)		$D_u - (2 \times t) = \text{Internal diameter } (D_i)$		D_i	
Transducer distance (L)				L ₁ =	
				L ₂ =	
Angle θ transducer 1A (angle 1A = 1B ; +/- 0,1°)				Average path angle "(1A + 1B) / 2"	
Angle θ transducer 1B (angle 1A = 1B ; +/- 0,1°)					
Cable length (distance from transducer to converter x 2)				Q _{max}	

B.6 Dimension dependent settings, SONOKIT 1-path

(Used dimension unit is [m])

Nominal size *)		Max. vol. flow	Pipe diameter	Path angle	Path length
[mm]	[inch]	[m ³ /h]	[m]	[°]	[m]
DN 100	4	100	0.1071	45	0.1795
DN 125	5	150	0.1317	45	0.2143
DN 150	6	220	0.1593	45	0.2533
DN 200	8	380	0.2083	60	0.2584
DN 250	10	600	0.2604	60	0.3185
DN 300	12	850	0.3098	60	0.3756
DN 350	14	1000	0.3396	60	0.4100
DN 400	16	1300	0.3904	60	0.4687
DN 450	18	1700	0.4500	60	0.5375
DN 500	20	2200	0.4920	60	0.5860
DN 550	22	2600	0.5500	60	0.6529
DN 600	24	3200	0.6016	60	0.7125
DN 650	26	3600	0.6500	60	0.7684
DN 700	28	4200	0.6952	60	0.8206
DN 750	30	4800	0.7500	60	0.8839
DN 800	32	5500	0.7968	60	0.9379
DN 900	36	7500	0.9100	60	1.0686
DN 1000	40	9000	1.0000	60	1.1726
DN 1100	44	10000	1.1000	60	1.2880
DN 1200	48	13200	1.2000	60	1.4035
DN 1300	52	14000	1.3000	60	1.5190
DN 1400	56	16800	1.4000	60	1.6344
DN 1500	60	19000	1.5000	60	1.7499
DN 1600	64	22800	1.6000	60	1.8654
DN 1700	68	25000	1.7000	60	1.9808
DN 1800	72	27600	1.8000	60	2.0963
DN 1900	76	31000	1.9000	60	2.2118
DN 2000	80	36000	2.0000	60	2.3273
DN 2100	84	37000	2.1000	60	2.4427
DN 2200	88	42000	2.2000	60	2.5582
DN 2300	92	45000	2.3000	60	2.6737
DN 2400	96	51000	2.4000	60	2.7891

*) For FUS080 transmitter based systems only up to DN1200

B.7 Ordering

In order to ensure that the ordering data you are using is not outdated, the latest ordering data is always available on the Internet: Catalog process instrumentation (<http://www.siemens.com/processinstrumentation/catalogs>)

Index

B

Battery indicator
 Reset, 31
Battery specifications, 62

C

Cable specifications, 21
Commissioning
 with PDM, 32
Compliance, 11
Contact person, 10
Customer Support Hotline, 52

D

Decontamination, 53
Description, 15
Device
 Identification, 8
 Inspection, 7
Diagnose
 with SIMATIC PDM, 56
Diagnostic parameters, 73
Document history, 9

E

EDD, 9
EDD files
 Download, 34
 Installation, 34
Electrical connection
 Cable specifications, 21
Error codes, 55
Ex Approval, 12

F

Factory settings, 83
Features, 16
Firmware, 9
Flow factor, 17

Flow velocity, 17

H

Hazardous areas, 12
Hotline, 52
Human Interface parameters, 80

I

Identification parameters, 69
Installation
 Ambient conditions, 19
 Indoor/outdoor, 19
 Pipe mounting, 20
 Wall mounting, 20
Internet
 Contact person, 10, 52
 Flowdocumentation, 10
 Support, 52
Introduction, 7
Items supplied, 7

L

Laws and directives, 11
Lithium batteries
 Return, 54
 Safety, 12
Local display, 29

M

Maintenance, 49
Material compatibility, 11
Measuring principle, 17
Menu items, 31
Meter setup parameters, 78
MODBUS network, 34

O

Output parameters, 73

P

PDM

- Commissioning, 32
- Pressure specifications, 19
- Protective conductor terminal, 22
- Protective earth, 22

R

- Repair, 49
- Return procedures, 53

S

- Safety, 11
 - Instrument safety standards, 11
- Sensor geometry measurement report, 87
- Service, 49, 52
 - Application data sheet, 53
- Support, 52

T

- Temperature specifications, 19
- Transit time, 17

V

- View process values, 41

W

- Wire insulation, 22

