

# SIEMENS

## SITRANS F

### Coriolis Flowmeters SIFLOW FC070 with SIMATIC S7

#### Operating Instructions

Coriolis flow transmitter for use with SITRANS F C sensors type MASS 2100, FCS200, FC300 and MC2

05/2012  
A5E02254228-04

ICS Schneider Messtechnik GmbH  
Briesestraße 59  
D-16562 Hohen Neuendorf / OT Bergfelde

Tel.: 03303 / 50 40 66  
Fax: 03303 / 50 40 68

info@ics-schneider.de  
www.ics-schneider.de

Introduction	1
Safety notes	2
Description	3
Hardware installation and removal	4
Connecting	5
Software installation	6
Programming in SIMATIC S7	7
Commissioning with SIMATIC PDM	8
Commissioning with SIMATIC S7	9
Custody transfer	10
Functions	11
Alarm, error, and system messages	12
Service and maintenance	13
Diagnosing and troubleshooting	14
Technical data	15
Spare parts/Accessories	16
SIFLOW Commands	A
SIFLOW Units	B
Data records	C
CT parameters	D
ESD guidelines	E
Abbreviations	F

## Legal information

### Warning notice system

This manual contains notices you have to observe in order to ensure your personal safety, as well as to prevent damage to property. The notices referring to your personal safety are highlighted in the manual by a safety alert symbol, notices referring only to property damage have no safety alert symbol. These notices shown below are graded according to the degree of danger.

<b>⚠ DANGER</b>
indicates that death or severe personal injury <b>will</b> result if proper precautions are not taken.

<b>⚠ WARNING</b>
indicates that death or severe personal injury <b>may</b> result if proper precautions are not taken.

<b>⚠ CAUTION</b>
with a safety alert symbol, indicates that minor personal injury can result if proper precautions are not taken.

<b>CAUTION</b>
without a safety alert symbol, indicates that property damage can result if proper precautions are not taken.

<b>NOTICE</b>
indicates that an unintended result or situation can occur if the relevant information is not taken into account.

If more than one degree of danger is present, the warning notice representing the highest degree of danger will be used. A notice warning of injury to persons with a safety alert symbol may also include a warning relating to property damage.

### Qualified Personnel

The product/system described in this documentation may be operated only by **personnel qualified** for the specific task in accordance with the relevant documentation, in particular its warning notices and safety instructions. Qualified personnel are those who, based on their training and experience, are capable of identifying risks and avoiding potential hazards when working with these products/systems.

### Proper use of Siemens products

Note the following:

<b>⚠ WARNING</b>
Siemens products may only be used for the applications described in the catalog and in the relevant technical documentation. If products and components from other manufacturers are used, these must be recommended or approved by Siemens. Proper transport, storage, installation, assembly, commissioning, operation and maintenance are required to ensure that the products operate safely and without any problems. The permissible ambient conditions must be complied with. The information in the relevant documentation must be observed.

### Trademarks

All names identified by ® are registered trademarks of Siemens AG. The remaining trademarks in this publication may be trademarks whose use by third parties for their own purposes could violate the rights of the owner.

### Disclaimer of Liability

We have reviewed the contents of this publication to ensure consistency with the hardware and software described. Since variance cannot be precluded entirely, we cannot guarantee full consistency. However, the information in this publication is reviewed regularly and any necessary corrections are included in subsequent editions.

# Table of contents

<b>1</b>	<b>Introduction.....</b>	<b>9</b>
1.1	How to read the Operating Instructions.....	9
1.2	Items supplied.....	11
1.3	Device identification.....	11
1.4	History.....	12
1.5	Further Information.....	13
<b>2</b>	<b>Safety notes.....</b>	<b>15</b>
2.1	General safety instructions.....	15
2.2	System expansions.....	15
2.3	Installation in hazardous area.....	15
2.4	Explosion protection information.....	18
2.5	Certificates.....	19
<b>3</b>	<b>Description.....</b>	<b>21</b>
3.1	Use in the automation environment.....	21
3.2	Design.....	25
3.3	Features.....	26
3.4	Theory of operation.....	28
<b>4</b>	<b>Hardware installation and removal.....</b>	<b>29</b>
4.1	Installation and removal of the SENSORPROM.....	30
4.2	DIP switches.....	33
4.2.1	MODBUS address switch.....	33
4.2.2	MODBUS slave address.....	33
4.2.3	Write protection.....	34
4.3	Assembly on the rail.....	34
<b>5</b>	<b>Connecting.....</b>	<b>35</b>
5.1	General instructions.....	35
5.2	General safety requirements.....	35
5.3	Assembling SIFLOW FC070 Ex CT.....	35
5.4	Wiring non-Ex modules.....	39
5.5	Wiring Ex modules.....	41
5.6	Sensor cable shielding.....	44
5.7	Connection examples.....	45

5.7.1	Connection to a MODBUS master over RS485.....	45
5.7.2	Connection to a MODBUS master over RS232.....	46
5.7.3	Connection of digital input, digital outputs and power supply.....	47
5.8	Partial functionality test.....	47
<b>6</b>	<b>Software installation.....</b>	<b>49</b>
6.1	S7 Software library installation.....	49
6.2	Installation of S7 Hardware support package.....	49
6.3	PDM driver installation.....	52
<b>7</b>	<b>Programming in SIMATIC S7.....</b>	<b>57</b>
7.1	SIFLOW FC070 in the cyclic S7 program.....	57
7.2	Functions of the S7 function block SIFL_FC (FB95).....	58
7.3	The data block DB_FLOW_PARA.....	59
7.4	Functions of data block DB_FLOW_VEC.....	65
7.5	Data records in data block DB_FLOW_PARA.....	65
7.6	Additional parameters in data block DB_FLOW_PARA.....	66
7.7	Examples.....	68
7.7.1	Read out process values for massflow and totalizer 2.....	68
7.7.2	Reset totalizer 2.....	70
7.7.3	Initialize batch mode.....	71
<b>8</b>	<b>Commissioning with SIMATIC PDM.....</b>	<b>77</b>
8.1	General instructions.....	77
8.2	Step 1: Reading parameters from SIFLOW FC070.....	78
8.3	Step 2: Setting basic parameters .....	78
8.4	Step 3: System optimization.....	79
8.5	Step 4: View process variables.....	80
<b>9</b>	<b>Commissioning with SIMATIC S7.....</b>	<b>81</b>
9.1	Setting the basic parameters in the HW-Config.....	81
9.2	Step-by-step guide to commissioning with S7.....	83
9.2.1	Step 1: Reading parameters into DB17 (DB_FLOW_PARA).....	85
9.2.2	Step 2: Setting basic parameters .....	87
9.2.3	Step 3: System optimization.....	89
9.2.4	Step 4: System ready for operation.....	90
<b>10</b>	<b>Custody transfer.....</b>	<b>95</b>
10.1	Identify actual SIFLOW version.....	95
10.2	Step-by-step guide for configuration of SIFLOW CT functions.....	95
10.3	Configuring the CT version.....	96
10.4	Enable write access.....	96
10.5	Hardware and software requirements.....	97

---

10.6	Installing the SIFLOW CT OCX.....	98
10.7	Removing the SIFLOW CT OCX.....	98
10.8	Compatibility requirements.....	98
10.9	Supported devices.....	99
10.10	Layout of the SIFLOW CT OCX.....	100
10.11	Error codes.....	101
10.12	Supported languages.....	101
10.13	Limitations.....	102
10.14	Configuring and operating the SIFLOW CT OCX.....	102
10.14.1	Creating the HMI project.....	102
10.14.2	Setting up the PLC connection.....	104
10.14.3	Setting up tag representing input data for OCX read.....	105
10.14.4	Setting up tag representing output data for OCX write.....	106
10.14.5	Building the HMI project and transferring it to the panel.....	107
10.14.6	Parameterizing SIFLOW FC070 Ex CT with Simatic PDM.....	108
10.14.7	Reading data between SIFLOW CT OCX and SIFLOW Ex module.....	109
10.15	Disable write access.....	109
10.16	Changing parameters in write protection mode with SIMATIC PDM.....	110
10.16.1	Changing parameters in write protection mode from S7 when mass flow is 0.....	111
10.16.2	Reading actual hardware and firmware versions from SIFLOW.....	111
10.17	CT parameters.....	112
10.18	Checking that SIFLOW is in CT mode.....	112
<b>11</b>	<b>Functions.....</b>	<b>115</b>
11.1	Zero point adjustment.....	115
11.2	Low flow cut-off.....	117
11.3	Empty pipe monitoring.....	117
11.4	Noise filter.....	118
11.5	Scaling and unit conversion.....	119
11.6	Limit value monitoring.....	121
11.7	Simulation.....	122
11.8	Output.....	125
11.8.1	Digital output.....	125
11.8.2	Pulse output.....	126
11.8.3	Frequency output.....	127
11.8.4	Phase shift output.....	128
11.8.5	Batch output.....	128
11.8.6	Two-stage batch output.....	131
11.8.7	Freezing and forcing outputs.....	132
11.9	Input.....	132
11.9.1	Digital input.....	132

11.10	Process Information.....	133
11.10.1	Process values.....	133
11.10.2	Fraction.....	134
11.10.3	Totalizer.....	135
11.11	Date and time.....	138
11.12	Service information.....	139
<b>12</b>	<b>Alarm, error, and system messages.....</b>	<b>141</b>
12.1	Messages and diagnostics.....	141
12.2	Interrupt behaviour.....	143
12.3	Diagnostics data.....	144
12.4	System diagnostics data bytes 0 to 3.....	147
12.5	Module-specific diagnostics data bytes 4 to 7.....	148
12.6	Sensor and process-specific diagnostics data, bytes 8 to 11.....	149
12.7	Error messages of SIFLOW FC070.....	151
12.7.1	Error type overview.....	151
12.7.2	Sensor errors (SE) and process errors (PE).....	152
12.7.3	Data and operating errors.....	156
12.7.4	Error information in the output parameter ERR_MSG_C or CMD_ERR_C.....	161
12.8	System status information.....	162
12.9	Slave diagnostics.....	164
<b>13</b>	<b>Service and maintenance.....</b>	<b>167</b>
13.1	Maintenance.....	167
13.2	Unit repair.....	167
13.3	Technical support.....	167
13.4	Return procedures.....	168
<b>14</b>	<b>Diagnosing and troubleshooting.....</b>	<b>171</b>
14.1	LED status display.....	171
14.2	Diagnostics with LED.....	172
14.3	Diagnosing with PDM.....	174
14.4	Troubleshooting sensor and unstable measurement values.....	175
14.4.1	General information.....	175
14.4.2	Step 1: Inspecting the application.....	176
14.4.3	Step 2: Performing a zero point adjustment.....	176
14.4.4	Step 3: Calculating the measurement error.....	177
14.4.5	Step 4: Improving the application.....	178
<b>15</b>	<b>Technical data.....</b>	<b>181</b>
15.1	MODBUS communication.....	183
15.2	Block diagram of SIFLOW FC070.....	184
15.3	Block diagram of SIFLOW FC070 Ex CT.....	184

15.4	Triggering of commands via digital input.....	185
15.5	Output characteristics.....	186
<b>16</b>	<b>Spare parts/Accessories.....</b>	<b>191</b>
16.1	Ordering.....	191
16.2	Ordering data.....	191
<b>A</b>	<b>SIFLOW Commands.....</b>	<b>193</b>
A.1	SIFLOW Commands.....	193
<b>B</b>	<b>SIFLOW Units.....</b>	<b>195</b>
<b>C</b>	<b>Data records.....</b>	<b>201</b>
C.1	DR2 Units of the process values (R/W).....	202
C.2	DR3 Basic settings (R/W).....	204
C.3	DR4 Totalizer (R/W).....	208
C.4	DR5 Digital output (R/W).....	210
C.5	DR6 Digital input (R/W).....	214
C.6	DR7 Interface parameters (R/W).....	215
C.7	DR8 Day/time (R/W).....	217
C.8	DR9 Sensor properties (R/W).....	218
C.9	DR10 Simulation data (R/W).....	220
C.10	DR11 Process value default settings (R/W).....	222
C.11	DR12 Limit default settings (R/W).....	224
C.12	DR30 Process values (R).....	228
C.13	DR31 Service information (R).....	228
C.14	DR32-34 Transmitter, sensor and customer data (R).....	230
C.15	DR35-36 MODBUS slave identification data and service information (R).....	232
C.16	DR37 CT values (R).....	234
C.17	DR39 CT parameters (R/W).....	235
C.18	DR181 Diagnostics buffer (R).....	236
<b>D</b>	<b>CT parameters.....</b>	<b>239</b>
D.1	Redundancy pulse output.....	239
D.2	Redundancy frequency output.....	241
D.3	OCX.....	243
<b>E</b>	<b>ESD guidelines.....</b>	<b>245</b>
<b>F</b>	<b>Abbreviations.....</b>	<b>247</b>
	<b>Glossary.....</b>	<b>251</b>
	<b>Index.....</b>	<b>257</b>





# Introduction

These Operating Instructions are applicable for the SIFLOW FC070 and SIFLOW FC070 Ex CT function modules which can be used in stand/alone mode or for linking industrial flowmeters to an S7 automation system.

The Operating Instructions enable you to look up reference information on operation, functions and technical specifications of the SIFLOW FC070 / SIFLOW FC070 Ex CT function module.

The Operating Instructions are intended both for programming and testing/debugging personnel who commission and maintain the module and connect it with other units (automation systems, programming devices), and for service and maintenance personnel who perform system expansions or carry out fault/error analyses.

---

## Note

The Operating Instructions contain the description of the current function module. For new function modules, or function modules of a more recent version, we reserve the right to publish the latest information on the Internet.

---

## 1.1 How to read the Operating Instructions

### Basic knowledge required

To be able to understand and work with the operating instructions, you will need to have a general knowledge of automation technology. Furthermore, experience in using sensors for flow measuring is helpful.

You should have knowledge of the system into which you wish to integrate the SIFLOW FC070 function module. Depending on the individual application, the following may be required:

- Knowledge of the S7 basic software
- Knowledge of the SIMATIC PDM configuration tool.

The integration of function modules in an S7-300 or ET 200M system (i.e. assembly and wiring) is described in the respective operating instructions for these systems.

---

## Note

### Observance of installation guidelines

The installation guidelines and safety instructions given in this documentation must be followed during commissioning and operation.

---

## Content of the single chapters

- "Safety notes" (Page 15) includes a safety application instruction.  
The user should read this instruction carefully if installing SIFLOW FC070 in hazardous or explosive areas.
- "Description" (Page 21) includes the basic description of SIFLOW FC070 and of the Coriolis measurement principle. This chapter also describes how SIFLOW FC070 can be integrated into automation applications.  
All users should read this chapter to have a basic knowledge of the module.
- "Features" (Page 115) describes all features offered by SIFLOW FC070 in detail.  
Here the user can gain an overview of the features of the module and also find more detailed information.
- "Hardware installation and removal" (Page 29) describes step by step how to install SIFLOW FC070, i.e. SENSORPROM installation, dip-switch setting, and assembly on the rail.  
All users should read this chapter before installing the hardware.
- "Connecting" (Page 35) describes how to connect the SIFLOW FC070 to sensor, I/Os and communication.  
All users should read this chapter before wiring the module.
- "Software installation" (Page 49) describes how to install the software provided with SIFLOW FC070, i.e. S7 software library, S7 HW support package and PDM driver.  
All users should read this chapter.
- "Programming in SIMATIC S7" (Page 57) describes how to communicate with SIFLOW FC070 by using the S7 function blocks and data blocks provided with the module.  
All users using S7 should read this chapter.
- "Commissioning with SIMATIC PDM" (Page 77) describes how to commission SIFLOW FC070 by use of SIMATIC PDM.  
It is recommended to use SIMATIC PDM for commissioning and diagnostics. All users who plan to commission the module with PDM and who are not familiar with PDM should read this chapter.
- "Commissioning with SIMATIC S7" (Page 81) describes in examples how to commission SIFLOW FC070 by use of S7 SIFLOW function blocks.  
The chapter refers to a PLC example code from the SIFLOW getting started package found on the CD provided with the product.  
All users planning to commission the module with SIMATIC S7 should read this chapter.
- "Custody transfer" (Page 95) describes how to set up a CT application by use of the Digital Output or by use of the SIFLOW CT OCX ActiveX component.  
All users planning to use the device in a custody transfer application should read this chapter.
- "Alarm, error and system messages" (Page 141) describes the structure of alarms, errors and system messages by use with SIMATIC S7.  
The user should read this chapter for programming the diagnostic functionality in PLC.
- "Diagnosing and troubleshooting" (Page 171) describes how the user can diagnose and troubleshoot SIFLOW FC070 by using SIMATIC PDM and the LED display on the module.
- "Technical data" (Page 181) includes detailed technical information on the SIFLOW FC070 and coriolis sensors.

- "Appendix A" (Page 193) describes commands supported in SIFLOW FC070.
- "Appendix B" (Page 195) lists all engineering units supported in SIFLOW FC070.
- "Appendix C" (Page 201) lists all data records supported in SIFLOW FC070.
- "Appendix D" (Page 239) lists all parameters for custody transfer applications.

### The following rules are applied in the document

The parameters of SIFLOW FC070 are written:

- [datarecord number (upper case)]: [parameter name].  
Example:  
DR3: Zero\_adjust\_time means "Zero adjust time" parameter in data-record number 3.

Upper case names indicate bits (e.g command, status or error bits) as described below:

- PE\_ZEROADJ\_OFFSET\_LIMIT: Process Error(PE) bit.
- ST\_ZERO\_ADJUST\_OFFSET\_LIMIT\_EXCEEDED: Status(ST) bit.
- CMD\_PARA\_CHANGE\_ACK: Command (CMD) bit.

## 1.2 Items supplied

### Scope of delivery

Included in delivery are:

- SIFLOW FC070 / SIFLOW FC070 Ex CT function module
- CD with hardware support package (HSP), function blocks and data blocks, GSD and EDD files, online help, user documentation, Getting Started demo software and CE approval.
- P-bus connector for SIMATIC bus
- Supplementary material (end sleeves and shrink tubing for connection work)

## 1.3 Device identification

### Inspection

1. Check for mechanical damage due to possible improper handling during shipment. All claims for damage are to be made promptly to the carrier.
2. Make sure the scope of delivery and the information on the nameplate correspond to the ordering information.

Identification

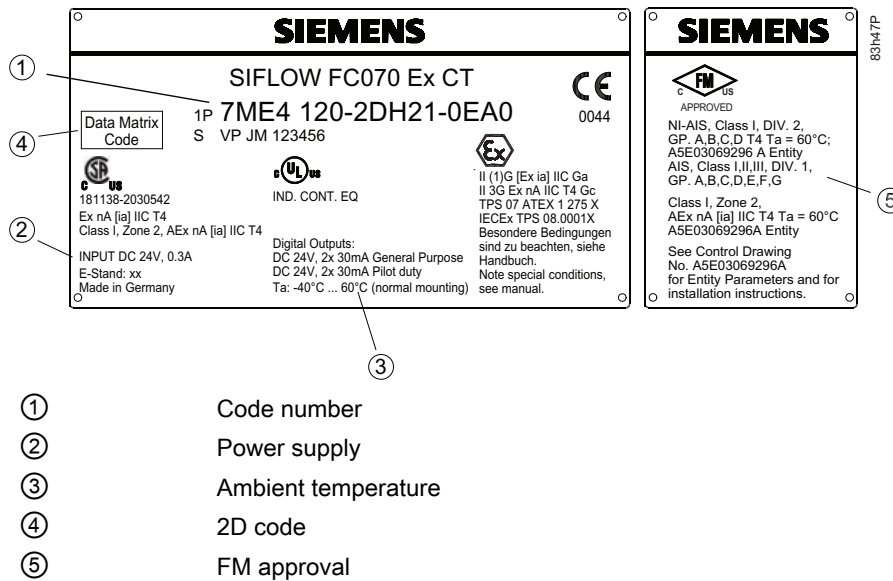

Figure 1-1 SIFLOW FC070 nameplate

1.4 History

The following table shows the most important changes in the documentation compared to each previous edition.

Edition	Remarks
09/2006	First edition of SIFLOW FC070 system manual See A5E00924779 ( <a href="http://support.automation.siemens.com/WW/view/en/24478991">http://support.automation.siemens.com/WW/view/en/24478991</a> )
06/2008	First edition of SIFLOW FC070 with SIMATIC S7 <ul style="list-style-type: none"> <li>All parts concerning configuration in PCS7, MODBUS, and PROFIBUS have been removed</li> <li>A step-by-step guide to commissioning has been added</li> <li>Troubleshooting information has been added</li> </ul>
04/2011	Second edition of SIFLOW FC070 with SIMATIC S7 <ul style="list-style-type: none"> <li>Description of an encrypted communication between SIFLOW FC070 and operating panel (OCX) has been added</li> <li>The CT part has been added</li> </ul>
03/2012	Third edition of SIFLOW FC070 with SIMATIC S7 <ul style="list-style-type: none"> <li>Update of Ex zone 2 certification standards</li> </ul>

## 1.5 Further Information

### Product information on the Internet

The Operating Instructions are available on the CD-ROM shipped with the device, and on the Internet on the Siemens homepage, where further information on the range of SITRANS F flowmeters may also be found:

Flowdocumentation (<http://www.siemens.com/flowdocumentation>)

### Worldwide contact person

If you need more information or have particular problems not covered sufficiently by these Operating Instructions, get in touch with your contact person. You can find contact information for your local contact person on the Internet:

Contact persons (<http://www.automation.siemens.com/partner/>)



## Safety notes

### 2.1 General safety instructions

 <b>CAUTION</b>
Correct, reliable operation of the product requires proper transport, storage, positioning and assembly as well as careful operation and maintenance. Only qualified personnel should install or operate this instrument.

---

**Note**

Alterations to the product, including opening or improper modifications of the product, are not permitted.

If this requirement is not observed, the CE mark and the manufacturer's warranty will expire.

---

### 2.2 System expansions

Only install system expansion devices designed for this device. The installation of other expansions can damage the system and violate the safety regulations and other directives.

Contact your technical support team or your sales outlet to find out which system expansions are suitable for installation.

<b>CAUTION</b>
If you cause system defects by installing or exchanging system expansion devices, the warranty becomes void.

### 2.3 Installation in hazardous area

 <b>WARNING</b>
Equipment used in hazardous areas must be Ex-approved and marked accordingly. It is required that the special conditions for safe use provided in the manual and in the Ex certificate are followed!

2.3 Installation in hazardous area

**Hazardous area approvals**

The device is approved for use in hazardous area and has the following approvals:

- SIFLOW FC070 Ex CT:
  - ATEX IECEX
  - II 3G Ex nA IIC T4 Gc
  - II (1)G [Ex ia] IIC Ga
- SIFLOW FC070:
  - II 3G Ex nA IIC T4 Gc

 <b>WARNING</b> Make sure the hazardous area approval is suitable for the environment in which the device will be installed.
--

**Intrinsically safe data**

Maximum values for SIFLOW FC070 Ex CT.

Table 2-1 Sensor driver output

<b>Connections X1 (Terminals 3 and 4)</b>	
$U_o$	16 V
$I_o$	66 mA
$P_o$	0.5 W
$C_o$	200 nF
$L_o$	5 mH

Table 2-2 Sensor pick-up input output

<b>Connections X1 (Terminals 12, 13, 15, and 16)</b>	
$U_o$	15 V
$I_o$	7.5 mA
$P_o$	0.028 W
$C_o$	200 nF
$L_o$	20 mH

Table 2-3 Sensor temperature output

<b>Connections X1 (Terminals 5, 6, 18, and 19)</b>	
$U_o$	15 V
$I_o$	5.8 mA
$P_o$	0.022 W
$C_o$	200 nF
$L_o$	10 mH



### Ambient temperature

T<sub>a</sub>: -40°C to 60°C with horizontal installation of the mounting rack,

T<sub>a</sub>: -40°C to 50°C with vertical installation of the mounting rack

 **WARNING**

With intrinsically safe circuits, use only certified meters appropriate for the transmitter.

If a non-conforming supply unit is used, the "fail-safe" type of protection will no longer be effective and the approval certification will be invalid.

### Special conditions for safe use

It is required that:

- Installation of the equipment must comply with national regulations. For example EN 60079-14 for the European Community.
- IEC/EN 61241-14 is considered for installation in areas with combustible dust.
- When protective earth (PE) is connected, no potential difference between the protective earth (PE) and the potential equalization (PA) can exist, even during a fault condition.

 **WARNING**

**Laying of cables**

Cable for use in zone 1 and 2 or 21 and 22 must satisfy the requirements for having a proof voltage > AC 500 V applied between the conductor/ground, conductor/shield and shield/ground.

Connect the devices that are operated in hazardous areas as per the stipulations applicable in the country of operation, e.g. for Ex "d" and "nA", permanent cables must be laid.

### Reference

You can find more information on separating intrinsically-safe and non-intrinsically-safe cables, and on the use of the DM 370 placeholder module, in the reference manual "Automation systems S7-300, M7-300, ET 200M, Ex I/O modules (<http://support.automation.siemens.com/WW/view/en/4068901>)" (part of the documentation package 6ES7 398-8RA00-8AA0).

## 2.4 Explosion protection information

SIFLOW FC070 complies with the salient safety specifications to IEC, EN, UL and CSA. If you have questions about the validity of the installation in the planned environment, please contact your service representative.

 <b>WARNING</b>
The device is designed for operation with Safety Extra-Low Voltage (SELV) from a Limited Power Source (LPS).
This means that only SELV / LPS complying with IEC60950-1 must be connected to the power supply terminals.
Provisions shall be made to prevent the rated voltage from being exceeded by transient system disturbances by more than 40 %.
This criteria is fulfilled, if supplies are derived from SELV, only.

 <b>WARNING</b>
EXPLOSION HAZARD: DO NOT DISCONNECT EQUIPMENT WHEN THE ATMOSPHERE IS FLAMMABLE OR EXPLOSIVE.

### Certifications and approvals

SIFLOW FC070	SIFLOW FC070 Ex CT
II 3G Ex nA IIC T4 Gc	II (1)G [Ex ia] IIC Ga
	II 3G Ex nA IIC T4 Gc

The testing station and test number can be found on the nameplate on the function module.

 <b>WARNING</b>
<ul style="list-style-type: none"> <li>• Modules with the approval Ex II 3G Ex nA IIC T4 Gc (SIFLOW FC070) are permissible for use in Zone 2 (ATEX Category 3G, IECEx EPL Gc).</li> <li>• Modules with the approvals Ex II 3G Ex nA IIC T4 Gc and Ex II (1)G [Ex ia] IIC Ga (SIFLOW FC070 Ex CT) are permissible for use in Zone 2 (ATEX Category 3G, IECEx EPL Gc). Intrinsically-safe sensors for Zone 0, 1 and 2 may be connected and used in areas subject to explosion hazard Zone 0, 1 or 2.</li> </ul>

### Specific ex requirements

- For operation *within* the area subject to explosion hazard (Zone 2), the function module must be installed in a suitable enclosure that guarantees at least degree of protection IP 54 in accordance with IEC/EN 60529. A manufacturer's declaration for Zone 2 must be submitted for the enclosure (in accordance with IEC/EN 60079-15).
- In situations where the temperature on the cable or at the cable inlet of this enclosure exceeds 70 °C (158 °F) or where the temperature on the wire branching point exceeds 80 °C (176 °F) under operating conditions, the temperature specifications of the cables must match the actually measured temperatures.
- Special conditions ("X conditions") must be met for SIFLOW FC070 Ex CT; See the table "Safety-related data (maximum values)" with the permissible ambient temperatures and mounting positions.
- Also note the standards EN 60079-0, EN 60079-14 and IEC/EN 60079-11 (Outside EU: IEC 60079-0, IEC 60079-11 and IEC 60079-14).

## 2.5 Certificates

Certificates are posted on the Internet and on the documentation CD-ROM shipped with the device.

### See also

Certificates (<http://www.siemens.com/processinstrumentation/certificates>)



## Description

### Measurement of liquids and gases

SITRANS F C Coriolis mass flowmeters are designed for measurement of a variety of liquids and gases. The meters are multi-parameter devices offering accurate measurement of mass flow, volume flow, density, fraction, °Brix/°Plato, and temperature.

### Main applications

The main applications of the Coriolis flowmeter can be found in all industries, such as:

- Chemical & Pharma: Detergents, bulk chemicals, pharmaceuticals, acids, alkalis
- Food & Beverage: Dairy products, beer, wine, softdrinks, °Brix/°Plato, fruit juices and pulps, bottling, CO<sub>2</sub> dosing, CIP/SIP-liquids
- Automotive: Fuel injection, nozzle & pump testing, filling of AC units, engine consumption, paint robots
- Oil & Gas: Filling of gas bottles, furnace control, CNG distribution, test separators
- Water & Waste Water: Dosing of chemicals for water treatment

## 3.1 Use in the automation environment

### Possible applications

The SIFLOW FC070 function module is used for linking sensors for flow measurements to an automation system.

SIFLOW FC070 can be used in the following automation environments:

- Centrally in S7-300
- Distributed in ET 200M
  - On S7-300
  - On S7-400
  - On standardized PROFIBUS DP/Profinet masters
- As MODBUS slave in stand-alone or parallel operation on MODBUS and SIMATIC, or operation on a third-party automation system (over RS232 or RS485 communications interface).  
A possible MODBUS master is the SIMATIC PDM (MODBUS RTU).

SIFLOW FC070 can also be used as a stand-alone device using the frequency and pulse outputs.

## Description

### 3.1 Use in the automation environment

Table 3-1 Possible configurations of SIFLOW FC070 (Ex) function module

Configuration	CPU	IM 153...	User interface	FB/DB	Requirements	Linking
Centralized S7-300, C7	All available	-	FB/DB in S7	FB SIFL_FC (FB95), DB_FLOW_PARA, DB_FLOW_VEC	HSP installation (OM)	Backplane bus
Distributed S7-300, distributed S7-400 (ET 200M)	All available	-1AA03 (ES 9 and higher) -2BA00 (Rel. 3.0.1 and higher) -2BB00 (Rel. 3.0.1 and higher)	FB/DB in S7	FB SIFL_FC (FB95), DB_FLOW_PARA, DB_FLOW_VEC	HSP installation (OM)	PROFIBUS DP
PCS 7 (ET 200M)	All available for PCS 7	-2BA00 (Rel. 3.0.1 and higher) -2BB00 (Rel. 3.0.1 and higher)	FB in S7, PCS 7 faceplate in WinCC	FB SFL_FC (FB695)	HSP installation (OM)	PROFIBUS DP
Distributed third-party systems (ET 200M)	DP-V1	-2BA00 (Rel. 3.0.1 and higher) -2BB00 (Rel. 3.0.1 and higher)	16-byte I/O, data records	-	GSD installation	PROFIBUS DP
Distributed third-party systems (ET 200M)	DP-V0	-2BA00 (Rel. 3.0.1 and higher) -2BB00 (Rel. 3.0.1 and higher)	16-byte I/O	-	GSD installation	PROFIBUS DP
Distributed S7-300, distributed S7-400 (ET 200M)	All available	- 4AA01 (Firmware 2.0.1 and higher)	FB/DB in S7	FB SIFL_FC (FB95), DB_FLOW_PARA, DB_FLOW_VEC	HSP installation (OM)	PROFINET
PCS 7 (ET 200M)	All available for PCS 7	- 4AA01 (Firmware 2.0.1 and higher)	FB in S7, PCS 7 faceplate in WinCC	FB SIFL_FC (FB95), DB_FLOW_PARA, DB_FLOW_VEC	HSP installation (OM)	PROFINET
Distributed third-party systems (ET 200M)	DP-V1	- 4AA01 (Firmware 2.0.1 and higher)	16-byte I/O, data records	-	GSD installation	PROFINET
Distributed third-party systems (ET 200M)	DP-V0	- 4AA01 (Firmware 2.0.1 and higher)	16-byte I/O, data records	-	GSD installation	PROFINET
MODBUS	PG/PC	-	MODBUS master (SIMATIC PDM)	-	EDD installation	RS232/485 MODBUS RTU
MODBUS	Third-party CPU	-	MODBUS master (e.g. Allen Bradley)	-		RS232/485 MODBUS RTU

3.1 Use in the automation environment

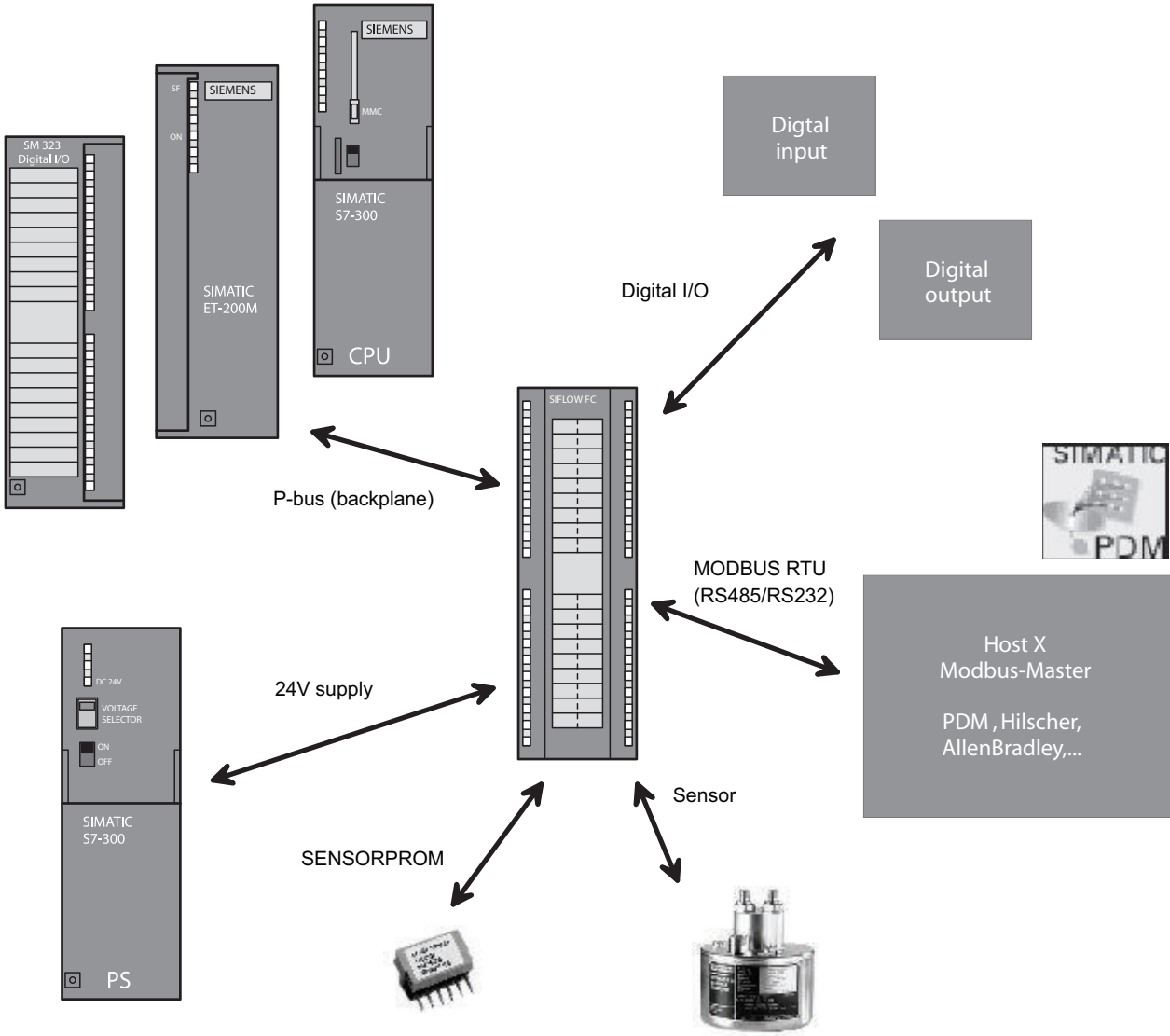

Figure 3-1 System overview of SIFLOW FC070 in automation environment

## Description

### 3.1 Use in the automation environment

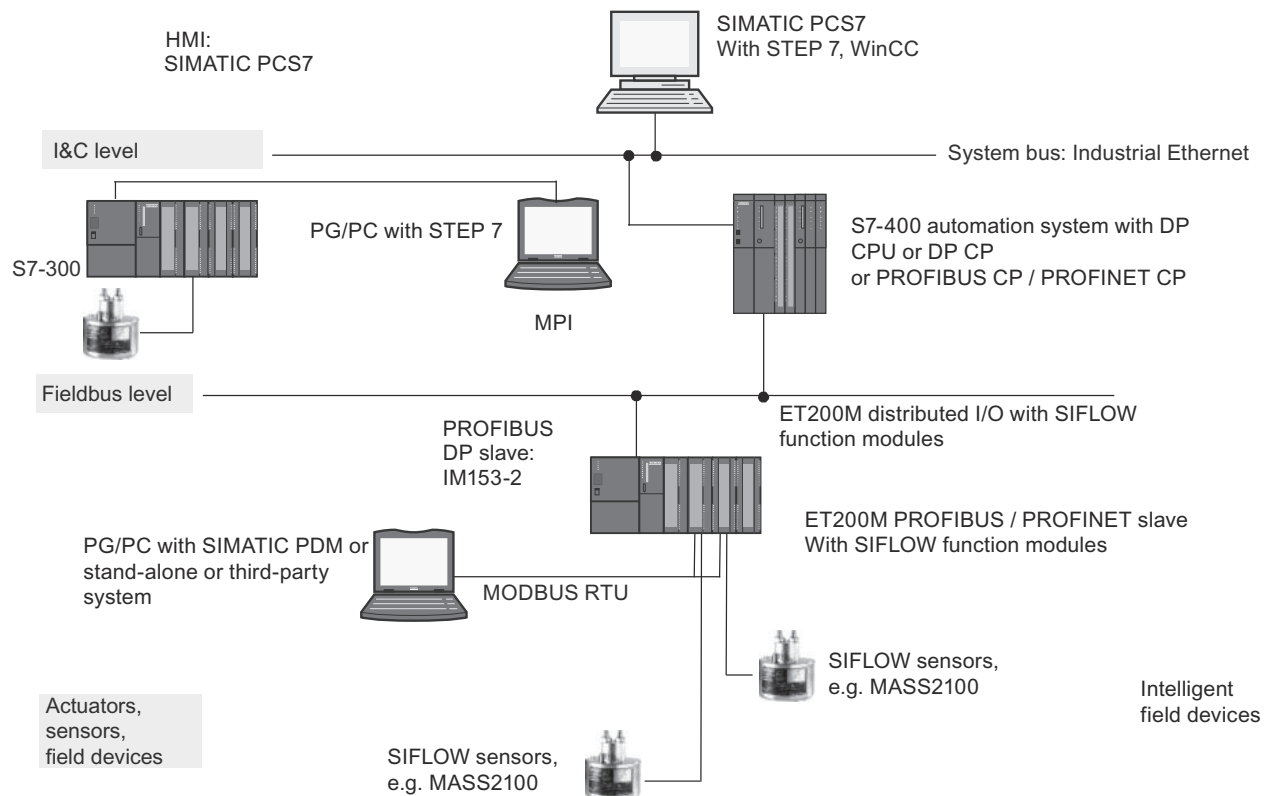

Figure 3-2 SIFLOW FC070 in automation environment

## Free downloads

The hardware support package (HSP file "s7h2008x.hsp"), function blocks and data blocks, GSD and EDD files, online help and user documentation are available for free downloading from the Intranet/Internet at:

Hardware support package (<http://support.automation.siemens.com/WW/view/en/24479364>)

## Address area

The address area of the SIFLOW FC070 function module is 16 bytes I/O.



## Configuration

The SIFLOW FC070 function module can be basically configured in different manners.

- In a SIMATIC S7-300 / S7-400 automation system with
  - S7 V5.3 or higher or
  - PCS 7 Engineering V6.0 or higher.

This is done by integrating the SIFLOW FC070 function module into the SIMATIC Manager using a hardware update (HSP, Hardware Support Package).

- In conjunction with an ET 200M distributed I/O system on a standardized PROFIBUS DP master system (third-party system).
- In conjunction with an ET 200M distributed I/O system on a standardized PROFINET master system (third-party system).  
In this case the corresponding GSD files for the respective IM 153-x are required.
- Over the MODBUS RTU interface:
  - With SIMATIC PDM, V5.2 and higher.  
In this case you integrate the SIFLOW FC070 function module by importing its EDD file in SIMATIC PDM.
  - Via the generic MODBUS protocol.

---

### Note

These operating instructions only feature configuration in SIMATIC S7. For use in PCS7, MODBUS or PROFIBUS please refer to FC070 System Manual (Order No. A5E00924779 (<http://support.automation.siemens.com/WW/view/en/24478991>)).

---

## 3.2 Design

SIFLOW FC070 (FC = Flowmeter Coriolis) is a transmitter function module with which industrial flow measurements and batching operations can be carried out according to the Coriolis principle.

SIFLOW FC070 has been designed for the SIMATIC S7-300 automation system, and uses the integrated communication, diagnostics system and configuration tools of this system.

SIFLOW FC070 can also be used for operation with MODBUS communication. This can be stand-alone or parallel operation on MODBUS and SIMATIC, or operation on a third-party automation system. Operator control (parameterization and control) and monitoring (HMI) can be carried out using SIMATIC PDM or a MODBUS tool, or a third-party automation system.

## Variants

The function module is available in two models:

- SIFLOW FC070
- SIFLOW FC070 Ex CT for operation of sensors in hazardous areas and custody transfer applications

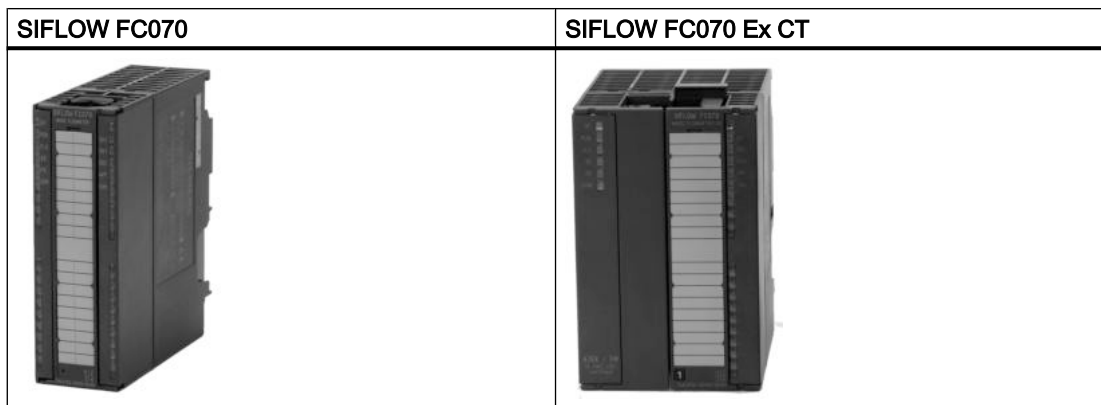

### System components

A SIFLOW system for industrial flow measurements consists of the following components:

- SIFLOW FC070 / SIFLOW FC070 Ex CT transmitter
- Sensor
- SENSORPROM
- Hardware support package (HSP), function blocks and data blocks, GSD and EDD files, online help and user documentation

### 3.3 Features

- Uniform design of SIMATIC S7-300 system
- Configuration with S7, PCS 7 Engineering or SIMATIC PDM
- Centralized use in the SIMATIC S7-300 automation system
- Distributed use in ET 200M over PROFIBUS DP or Profinet
- Use as MODBUS slave in stand-alone or parallel operation on MODBUS and SIMATIC, or operation on a third-party automation system
- High noise immunity
- Fast flow response and batching
- Fast step-forced response and high updating rate
- Measurement of:
  - Mass flow
  - Volume flow
  - Fraction flow
  - % fraction (e.g. °Brix)
  - Density
  - Sensor temperature

- Two totalizers for summation of mass and volume, depending on setting, of:
  - Mass flow measurement
  - Fraction flow measurement (A and B)
  - Volume flow measurement
- Low-flow cut-off function
- Empty pipe monitoring
- Limit value monitoring
- Scaling and unit conversion
- Digital output 1 can be parameterized for:
  - Pulse output
  - Frequency output
  - Batching (dosing)
- Digital output 2 together with digital output 1 for:
  - Two-stage batch or
  - Phase shift 90° or
  - Phase shift 180°
- Digital input, can be parameterized for:
  - Batch (dosing) control
  - Totalizer control (resetting of totalizers)
  - Zero adjustment
  - Setting or freezing a frequency at the digital outputs if these are set to "Frequency"
- Simulation of:
  - Process values
  - Digital outputs
  - Digital input
  - Faults
- Automatic configuration of function module with data from the SENSORPROM® memory unit during startup
- Comprehensive diagnostics functions for troubleshooting and sensor checking
- Use in hazardous area zone 2 (SIFLOW FC070 with enclosure)
- Use of sensors in hazardous area, zones 0, 1 and 2 (SIFLOW FC070 Ex CT)

### 3.4 Theory of operation

- Independent calibration of SIFLOW FC070 and the sensor guaranteeing the same measuring accuracy if e.g. the function module is replaced. The calibration data of the sensor as well as the user settings are saved in a SENSORPROM which can be used further if the module is replaced. The data are thus retained. The calibration data for the function module are stored in the FLASH of the SIFLOW FC070 itself.
- Encrypted backplane communication between SIFLOW FC070 and Siemens operating panel using OCX ActiveX component

## 3.4 Theory of operation

The flow measuring principle is based on the Coriolis law of motion.

Particles moving in a rotating/oscillating system will resist the imposed oscillations in a manner consistent with the mass and velocity (momentum). Oscillations produced by a Coriolis flowmeter as the process media is accelerated around bends result in phase distortions of the measuring tubes.

The SITRANS F C sensors are energized by an electromechanical driver circuit which oscillates the pipe at its resonant frequency. Two pickups, S1 and S2, are placed symmetrically on either side of the driver.

When the media flows through the sensor, Coriolis force will act on the measuring tube and cause a tube deflection which can be measured as a phase shift between pickup S1 and pickup S2.

The phase shift is proportional to the mass flowrate. The frequency and amplitude of the driver are automatically regulated to ensure a stable output from the 2 pickups in the region of 80 to 120 mV. The temperature of the sensor tubes is measured by a Pt1000, in order to enable accurate compensation for changes in the material stiffness. As a result the process media temperature is also accurately measured.

The flow proportional phase signal from the pickups, the temperature measurement and the driver frequency enable calculation and reporting of mass, density, volume, and temperature.

## SENSORPROM

All SITRANS F C Coriolis flowmeters feature a SENSORPROM memory unit which stores sensor-specific calibration data and transmitter settings for the lifetime of the product. The factory settings matching the sensor are stored in the SENSORPROM. At commissioning the flowmeter commences a typical flow measurement without any initial programming. Also customer-specified settings are downloaded to the SENSORPROM.



Figure 3-3 SENSORPROM memory unit

# Hardware installation and removal

## Worth knowing before installing

The SIFLOW FC070 can be used:

- In the automation system
- In stand-alone mode

Installation is in three steps for both types of use:

1. Installation of the SENSORPROM
2. Setting of DIP switches
3. Assembly

 <b>WARNING</b>
--

When used under hazardous conditions (Zone 2), the device must be installed in an enclosure of minimum IP54 protection degree according to IEC/EN 60529.
--

The enclosure must meet the requirements of IEC/EN 60079-15.
--

## Module replacement

Hot swapping of SIFLOW FC070 is not permissible. Switch off the 24 V DC supply voltage to the SIFLOW FC070 before replacing it.

---

### Note

You must wait at least 3 seconds after the last change to parameters before switching off the function module; otherwise loss of data might occur in the SENSORPROM.

---

 <b>WARNING</b>
--

Improper handling of front connectors could result in injury or damage to property.
---

Replug the SENSORPROM from the old function module into the new one. The last parameters used are saved in the SENSORPROM and are automatically uploaded when starting up.

## 4.1 Installation and removal of the SENSORPROM

### SENSORPROM for data and settings

The sensor is delivered with an associated SENSORPROM which has been preconfigured for the sensor used (with calibration data etc.). This SENSORPROM contains sensor data and transmitter settings for the SIFLOW FC070 function module.

### Installation



The housing of the SIFLOW FC070 / SIFLOW FC070 Ex CT has a cutout at the rear for installation of the SENSORPROM.

<b>CAUTION</b>
----------------

Switch off the 24 V DC supply voltage to the SIFLOW FC070 / FC070 Ex CT before installing/removing the SENSORPROM.
--



## Installation steps

Table 4-1 How to install the SENSORPROM

Step	Activity	
1.	<p>Insert the SENSORPROM into its slot on the rear of the module.</p> <p><b>Note:</b> The SENSORPROM cannot be inserted wrongly into the slot.</p>	
2.	<p>Push the SENSORPROM into the slot until it is flush with the rear of the module.</p> <p>When the SIFLOW FC070 is installed on the DIN rail, the SENSORPROM is secured against becoming loose.</p>	

Removal steps

Table 4-2 How to remove the SENSORPROM

Step	Activity	
1.	Carefully insert a standard screwdriver into the top cutout.	
2.	Slide the SENSORPROM sufficiently far out of the slot until you can grasp it from behind.	

**Note**

Installation/removal of the SENSORPROM for SIFLOW FC070 Ex CT in the 80 mm wide enclosure is carried out in the same way as shown in the tables above and with the SENSORPROM oriented in the same direction as in the case of the SIFLOW FC070 in the 40 mm wide enclosure.



## 4.2 DIP switches

### 4.2.1 MODBUS address switch

The SIFLOW FC070 module has two DIP switches located on the side of the SIFLOW function module enclosure: the MODBUS slave address switch and the write protection switch.

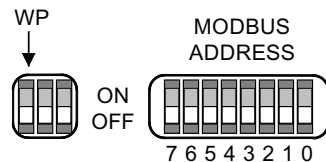

Figure 4-1 Write protection (WP) and Modbus address switches

### 4.2.2 MODBUS slave address

For communication over MODBUS, the associated MODBUS slave address must be set. Using this address, the SIFLOW FC070 function module can be individually addressed by the MODBUS master.

Two options are available for setting the MODBUS slave address:

- Set "0" on the DIP switch if you wish to set the MODBUS slave address with PDM or SIMATIC. The function module starts up with default slave address = 1. The connection must first be established point-to-point with slave address "1". Then the slave address can be changed via SIMATIC PDM or via SIMATIC S7 in HW-Config (basic parameter "Device Address").

Set "1...247" on the DIP switch if you wish to set a fixed (hardware-defined) MODBUS slave address (slave address from SIMATIC PDM or SIMATIC S7 will be ignored).

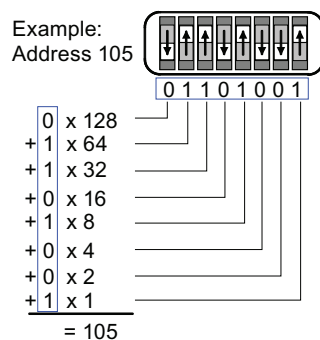

Figure 4-2 Example of MODBUS slave address

### 4.3 Assembly on the rail

#### 4.2.3 Write protection

Next to the MODBUS slave address switch, the write protection switch is present in a further cutout. The write protection switch is the furthest switch on the left. The other two switches are not used and should be left "OFF".

By activating this write protection the parameters can only be read from the device. Using the switch, you can prevent firmware updates from being transferred unintentionally to the function module.

With "ON", the write protection is active.

### 4.3 Assembly on the rail

SIFLOW FC070 is a function module of the SIMATIC S7-300 system, and can be directly connected to the automation system via the backplane bus.

The assembly/cabling overhead of the 40 or 80 mm wide function module is greatly reduced by the snap-on DIN rail mounting.

#### Requirements

- Configuration of the automation system has been completed
- The mounting rail is installed

---

#### Note

The DIN rail is mounted horizontally as standard. With vertical mounting of the DIN rail, the SIFLOW FC070 may only be operated at lower ambient temperatures, see "Technical data" (Page 181).

---

#### Note

When combining SIMATIC components with the SIFLOW FC070, the installation guidelines of SIMATIC PCS 7 must be observed. Detailed descriptions can be found in the respective SIMATIC manuals covering the installation of the ET200M automation system.

---

#### Installation steps

SIFLOW FC070 is installed in the following steps:

1. Check that the bus connector is plugged into the module on the left of the SIFLOW FC070.
2. Insert the bus connector to the next module on the right side of the SIFLOW FC070 (if present).
3. Hook the SIFLOW FC070 onto the top of the rail, push it against the left-hand module, and swing it down into place.
4. Tighten the SIFLOW FC070 to the bottom part of the rail using one screw (two screws for the SIFLOW FC070 Ex CT).
5. Label the SIFLOW FC070 according to your identification system.

## Connecting

### 5.1 General instructions

 <b>WARNING</b>
If the temperature at the cable or conduit entry point exceeds 70 °C (158 °F) or the temperature at the branching point of conductors exceeds 80 °C (176 °F), special precautions must be taken.
When the device is operated at ambient temperatures (air) of 50 to 60 °C (122 °F to 140 °F), it is essential that the cables used are approved for a maximum operating temperature of at least 85 °C (185 °F).

#### See also

Automation systems S7-300, M7-300, ET 200M, Ex I/O modules (<http://support.automation.siemens.com/WW/view/en/4068901>)

### 5.2 General safety requirements

 <b>WARNING</b>
<b>The pertinent regulations must be observed for electrical installation.</b>
<ul style="list-style-type: none"><li>• Never install the device with the mains voltage switched on!</li><li>• Danger of electric shock!</li></ul>

### 5.3 Assembling SIFLOW FC070 Ex CT

#### Prerequisites

 <b>WARNING</b>
For FC070 Ex CT intrinsically safe installation all relevant partitions, connecting cables and connections must meet the conditions of IEC/EN 60079-11.

### Assembling the module

 <b>WARNING</b>
<b>Use of partition</b>
While power on, the supplied partition must always be installed in the function module between intrinsically and non-intrinsically safe circuits.
<ul style="list-style-type: none"><li>• Ensure that the partition is installed as shown in the figures below so that a minimum gap of 50 mm (1.97") (minimum thread length) is maintained between the non-intrinsically safe connections (X2, X3 and X4, left) and the sensor connection (X1, right).</li></ul>

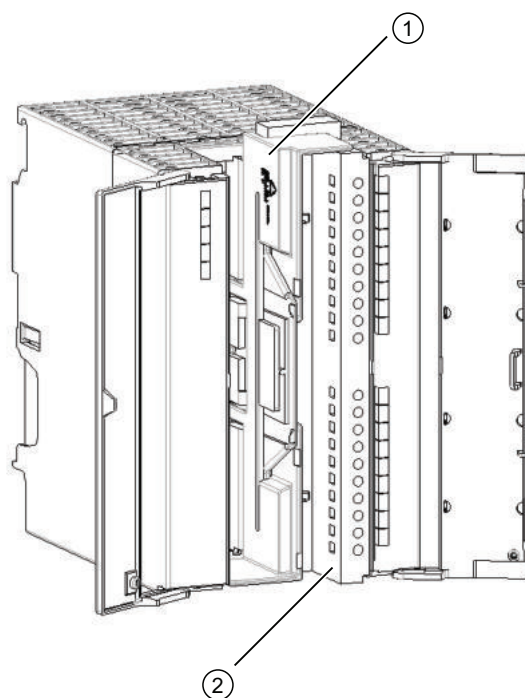

- (1) Partition
- (2) Sensor connector

SIFLOW FC070 Ex CT partition in place

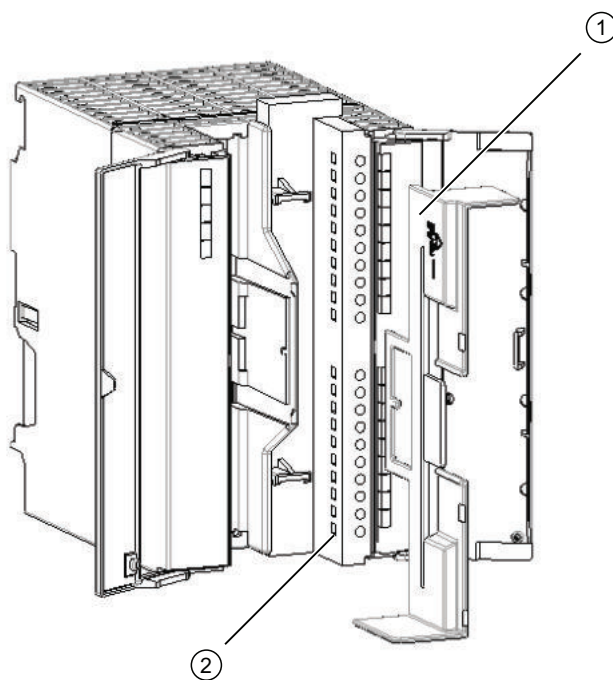



- (1) Partition
- (2) Sensor connector

Using the SIFLOW FC070 Ex CT partition

1. Remove the partition before connecting the cables.
2. Wire the sensor connector X1 and plug it in on the right of the plug connector, see "Wiring Ex modules".
3. Insert the partition as shown in the figures above.

4. Insert X2, X3 and X4 in the corresponding plug connectors on the left side.
5. Connect the shield to terminals 1, 2, 14, 17 and 20 of the 20-pole front connector X1 provided for this purpose.

 <b>CAUTION</b>
Cables of plug connectors X2, X3 and X4 must be run upwards out of the function module and the cable shieldings must be connected, if required, to grounded shielding terminals.

 <b>CAUTION</b>
Avoid connecting the shielding of the sensor connecting cable direct to ground on the side of the SIFLOW FC070 Ex CT function module.

 <b>CAUTION</b>
Route intrinsically safe and non-intrinsically safe conductors in separate cable ducts in order to ensure strict separation in the wiring system.

**Note**

If the minimum thread length between conducting parts of Ex modules and standard modules is < 50 mm (1.97"), the thread length between the modules can be maintained in two ways:

- Insert the placeholder module DM 370 (6ES7 370-0AA01-0AA0) between the affected Ex and standard modules.
- When using the bus modules of the active backplane bus, you can also use the Ex partition (6ES7 195-1KA00-0XA0).

**See also**

Wiring Ex modules (Page 41)

Automation systems S7-300, M7-300, ET 200M, Ex I/O modules (<http://support.automation.siemens.com/WW/view/en/4068901>)

## 5.4 Wiring non-Ex modules

### Connection element locations

All signals for the SIFLOW FC070 function module are connected to a 40-pole front connector.



Figure 5-1 Front connector (non-ex version)

### Connecting the front connector

1. Wire the front connector as described in the SIMATIC S7-300, CPU 31xC and CPU 31x operating instructions: *Installation*.  
For pin assignments of the front connector, see below.
2. Connect the wire shields using a terminal element as described in the SIMATIC S7-300, CPU 31xC and CPU 31x operating instructions: *Installation*.  
Connection of the shield only to the front connector is not suitable as an EMC earthing measure.
3. Connect the sensor to the front connector using the 10-core cable that is supplied with the sensor.  
For the color coding of the sensor signals, see below.

Pin assignments of front connector

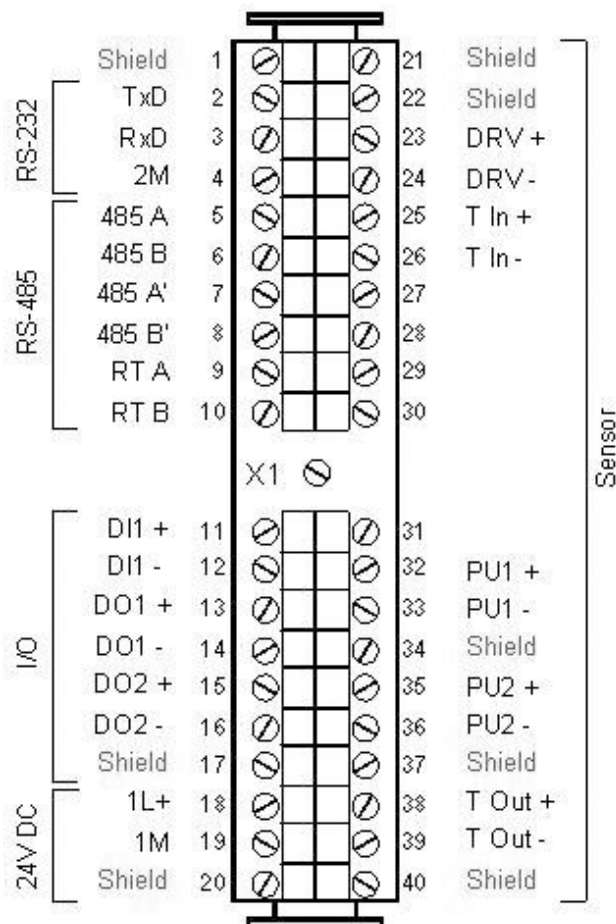

Figure 5-2 Pin assignments of SIFLOW FC070 front connector

The 8 pins "Shield" (earth) are connected within the module to the DIN rail.

Color coding of sensor cable

Pin	Signal	Color	Meaning
23	DRV +	brown	Driver +
24	DRV -	red	Driver -
25	T In +	orange	Temperature input +
26	T In -	yellow	Temperature input -
32	PU 1+	green	Sensor pickup 1 +
33	PU 1-	blue	Sensor pickup 1 -
35	PU 2+	violet	Sensor pickup 2 +
36	PU 2-	gray	Sensor pickup 2 -
38	T Out +	white	Temperature output +



Pin	Signal	Color	Meaning
39	T Out -	black	Temperature output -
21, 22, 34, 37, 40	Shield	--	Shield (earth)

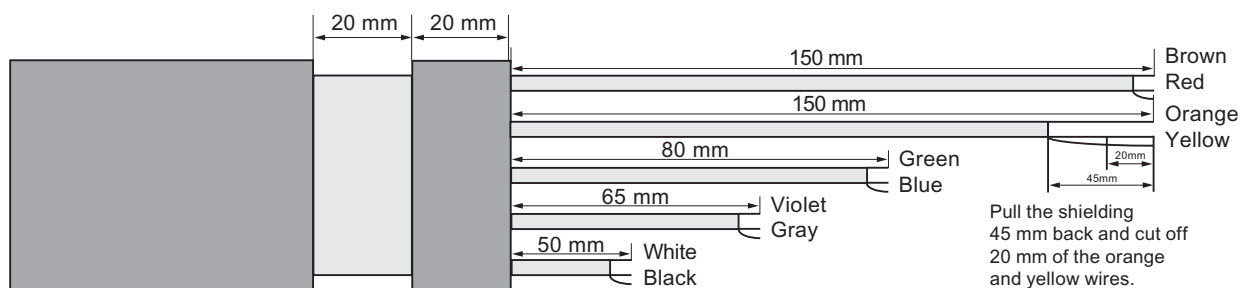

Figure 5-3 Wiring

## 5.5 Wiring Ex modules

### Connection element locations

All signals for the SIFLOW FC070 Ex CT function module are connected to a 10/7/3-pole front connector and to a 20-pole front connector.

- Sensor to the 20-pole front connector (X1)
- Communications interfaces to the 10-pole front connector (X2)
- Digital inputs/outputs to the 7-pole front connector (X3)
- Power supply to the 3-pole front connector (X4)



Figure 5-4 Front connector (ex version)

**Connecting the front connector**

1. Wire the 20-pole front connector (X1) as described in the SIMATIC S7-300, CPU 31xC and CPU 31x operating instructions: *Installation*.  
For pin assignments of the front connector, see below.
2. Wire-up the 10-, 7- and 3-pole front connectors (X2; X3; X4).
3. Connect the sensor to the front connector using the 10-core cable that is supplied with the sensor.  
For the color coding of the sensor signals, see below.

**Pin assignments of SIFLOW FC070 Ex CT front connector**

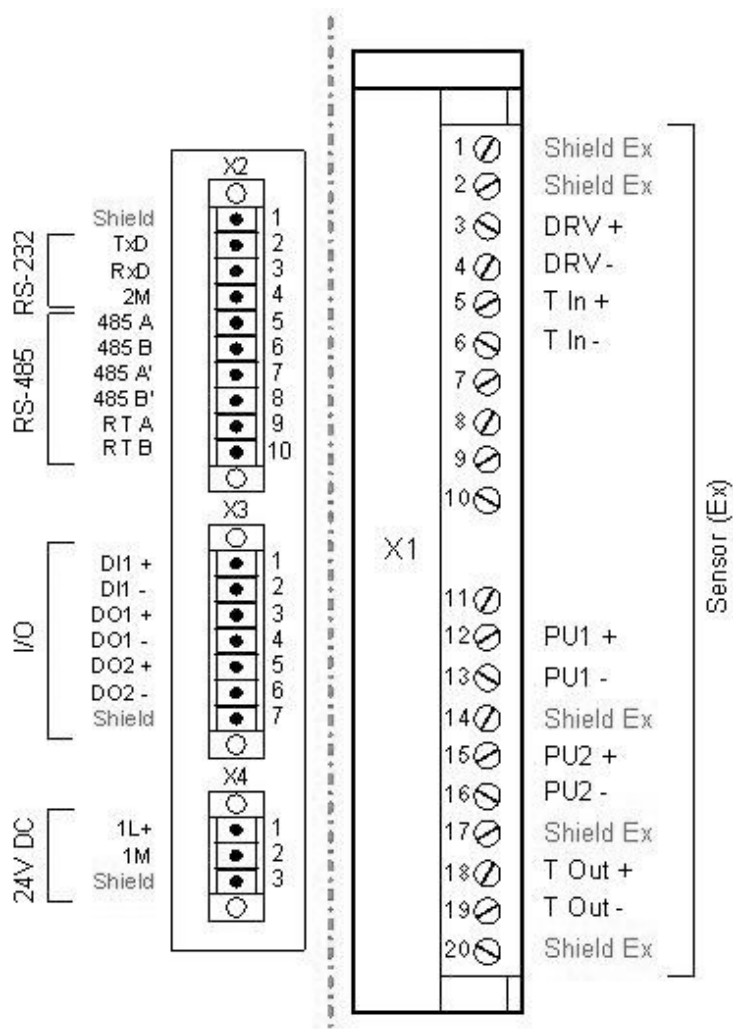

Figure 5-5 Pin assignments of the Siflow FC070 Ex CT front connector

- The 3 pins "SHIELD (earth)" are connected within the module to the DIN rail.
- The 5 pins "SHIELD (Ex)" are connected within the module, but insulated from the "SHIELD (earth)".

### Color coding of sensor cable

Pin	Signal	Color	Meaning
3	DRV +	brown	Driver +
4	DRV -	red	Driver -
5	T In +	orange	Temp. input +
6	T In -	yellow	Temp. input -
12	PU 1+	green	Sensor pick-up 1 +
13	PU 1-	blue	Sensor pick-up 1 -
15	PU 2+	violet	Sensor pick-up 2 +
16	PU 2-	gray	Sensor pick-up 2 -
18	T Out +	white	Temp. output +
19	T Out -	black	Temp. output -
1, 2, 14, 17, 20	Shield Ex	--	Shield (Ex)

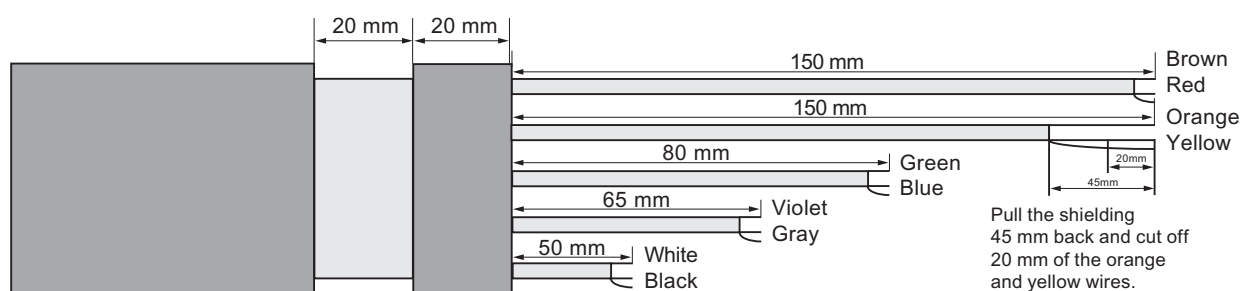

Figure 5-6 Wiring

#### **⚠ WARNING**

Do NOT connect the shielding of the sensor connecting cable directly to ground on the side of the SIFLOW FC070 Ex CT function module. Connect the shield to terminals 1, 2, 14, 17 and 20 of the 20-pole front connector X1 provided for this purpose.

#### **⚠ WARNING**

The connections X2, X3 and X4 (left side) are NOT intrinsically-safe and cables attached to these connections must NOT be run into the area subject to explosion hazard.

## 5.6 Sensor cable shielding

**⚠ WARNING**

Ensure that there is no unprotected sensor cable shield outside the transmitter.



Figure 5-7 Correct sensor cable shielding

## 5.7 Connection examples

### 5.7.1 Connection to a MODBUS master over RS485

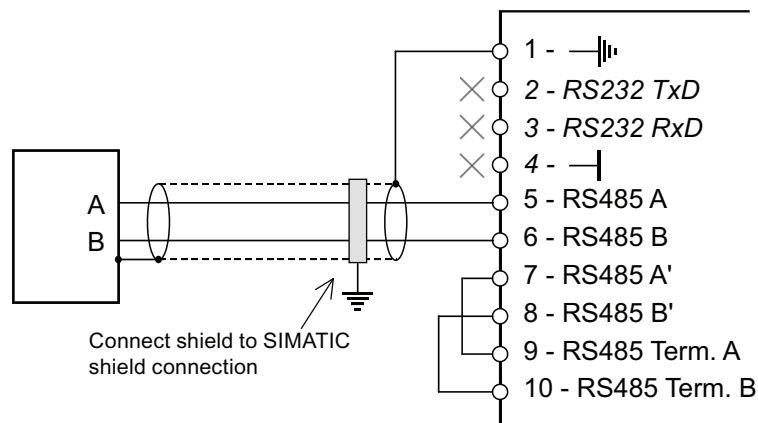

#### Directions

- Do not use pins 2 and 3 of the SIFLOW FC070.
- Pin 4 (ground) can be optionally connected.
- Connect a jumper between pins 7 and 9 as termination.
- Connect a jumper between pins 8 and 10 as termination.
- Connect the cable shield to the SIMATIC shield connecting element.

### 5.7.2 Connection to a MODBUS master over RS232

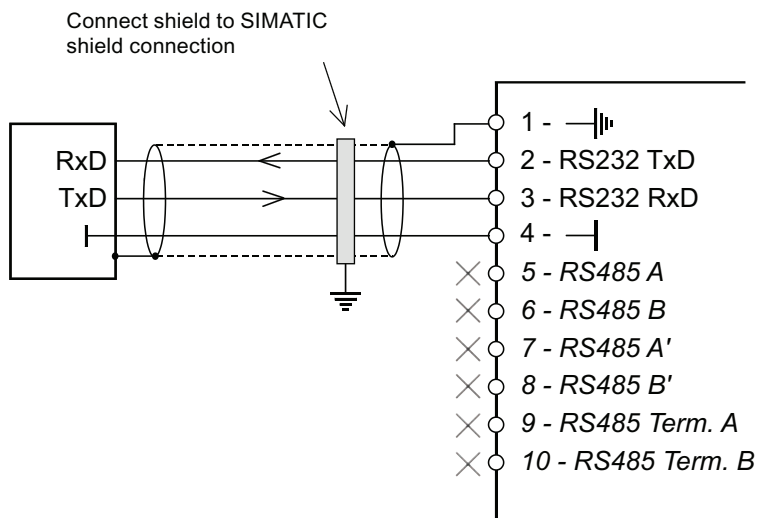

**Note**

Pins 1-10 in the above figure belong to front connector X1 on the SIFLOW FC070, and to front connector X2 (behind the left-hand door) on the SIFLOW FC070 Ex CT.

**Directions**

1. Connect the receive line RxD of the MODBUS master to the send line TxD (pin 2) of the SIFLOW FC070.
2. Connect the send line TxD of the MODBUS master to the receive line RxD (pin 3) of the SIFLOW FC070.
3. Connect the cable shield to the SIMATIC shield connecting element.

**CAUTION**

Do not use pins 5 to 10 of the SIFLOW FC070.

### 5.7.3 Connection of digital input, digital outputs and power supply

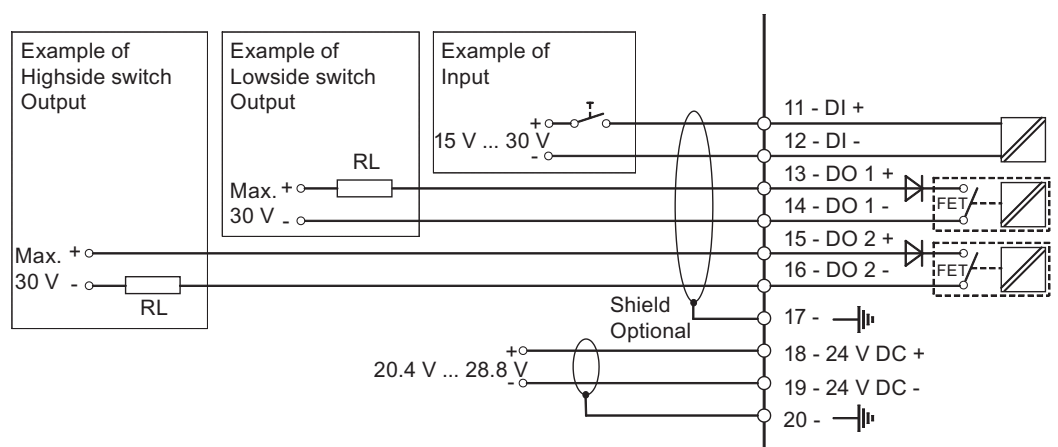

Figure 5-8 Connection of digital input, outputs and power supply

#### Note

Please note that the above figure shows the pins of the SIFLOW FC070. The following applies to the SIFLOW FC070 Ex CT:

- Pins 11-17 on front connector X1 correspond to pins 1-7 on front connector X3 on the SIFLOW FC070 Ex CT.
- Pins 18-20 on front connector X1 correspond to pins 1-3 on front connector X4 on the SIFLOW FC070 Ex CT.

See also the figure "Pin assignments of SIFLOW FC070 Ex CT front connector".

## 5.8 Partial functionality test

At this point, after assembling the module group and making all connections, you should perform a partial functionality test for the SIFLOW FC070 and the connected components.

In the following a step-by-step description of how to perform the partial functionality test is provided:

### Step 1: Visual check

Check all previously performed steps for proper execution, i.e.:

- Is there any external damage to the module group?
- Are the modules situated in the proper positions?
- Are all fastening screws properly tightened?
- Are all connecting cables properly connected and fastened tightly?
- Is the frontal connection made properly?

- Is the shielding properly attached to the shielding conductor for all corresponding cables?
- Is the profile rail connected to the ground conductor?
- Are all tools, materials and components that do not belong to the SIFLOW FC070 removed from the profile rail and the module group?

### Step 2: Connecting

- Connect SIFLOW FC070 with 24 V supply
- Switch power supply on

---

#### Note

**Proper initialization of the SIFLOW FC070 in the SIMATIC can only be guaranteed if:**

- the SIMATIC CPU (with decentralized connection with ET 200 M) and the SIFLOW FC070 are switched on at the same time  
or
  - the SIFLOW FC070 is switched on first
- 

### Step 3: LED check

After attaching the 24 V supply voltage and a short initialization phase (internal testing is indicated by LED running pattern), the SIFLOW FC070 goes into operational status.

The following LEDs must have the status that is indicated below if the unit is running correctly:

- LED (RUN) → ON status
- LED (FLO) → Flash status if measuring flow - otherwise OFF status.
- LED (SF) → OFF status

In case of error refer to the chapter "Troubleshooting/FAQs" (Page 171).

If an error still occurs after verifying the installation and connection, then proceed with the commissioning and use either SIMATIC PDM or SIMATIC PCS 7 to identify the error.



## Software installation

The following SW installation package is provided with SIFLOW FC070:

- SIFLOW S7 SW library
- SIFLOW S7 HW support package
- SIFLOW PDM device driver (EDDL driver)
- SIFLOW CT OCX package

The SW installation package can be found on the CD provided with the module and the latest version is available for a free download at:

<http://support.automation.siemens.com> (<http://support.automation.siemens.com/WW/view/en/23781606/133100>)

### 6.1 S7 Software library installation

In order for the SIFLOW FC070 to be accepted into the module assembly catalogue of the SIMATIC manager, the SETUP (start.exe) program (supplied with the CD) must be executed.

The S7 SW library update/installation basically consists of the following steps:

1. Download "SiFlow FC Library for S7 Vxx.zip" of the update from the Internet, or copy it from the supplied CD into the envisaged folder and unzip the file.
2. Open "Setup" folder from your hard disk, execute "setup.exe", follow the wizard steps and the library blocks will be copied to the S7 environment.
3. Open the SIMATIC manager and copy SIFLOW library blocks (SIFL\_FC, DB\_FLOW\_VEC, DB\_FLOW\_PARA and UDT\_SIFL\_FC) to the SIMATIC S7 project.

---

#### Note

The SIFLOW library (SIFL\_FC) can be accessed from SIMATIC Manager -> File -> Open -> Libraries.

---

### 6.2 Installation of S7 Hardware support package

The SIFLOW FC070 function module is not located in the S7 module catalog, but is subsequently installed using a hardware update (Hardware Support Package "s7h2008x.hsp"). This hardware update contains the user GUI for HW-Config and online help.

### Step-by-step installation guide

The procedure for installing the HW support package consists of following steps:

1. Download "hsp2008.zip" of the update from the Internet, or copy it from the supplied CD into the envisaged folder and unzip the file.
2. Open the project in SIMATIC Manager and start up the HW Configuration.
3. In HW-Config, select the menu command Options > Install HW updates.
4. In the next dialog you define whether to download a hardware update from the Internet or copy it from CD, or to install updates which have already been downloaded (selection possible).
5. Select the components to be installed (e.g. "Copy from disk" -> execute and browse to the copied files on hard disk), and click the "Install" button.

### HW configuration in ET200M (Example for PROFIBUS DP)

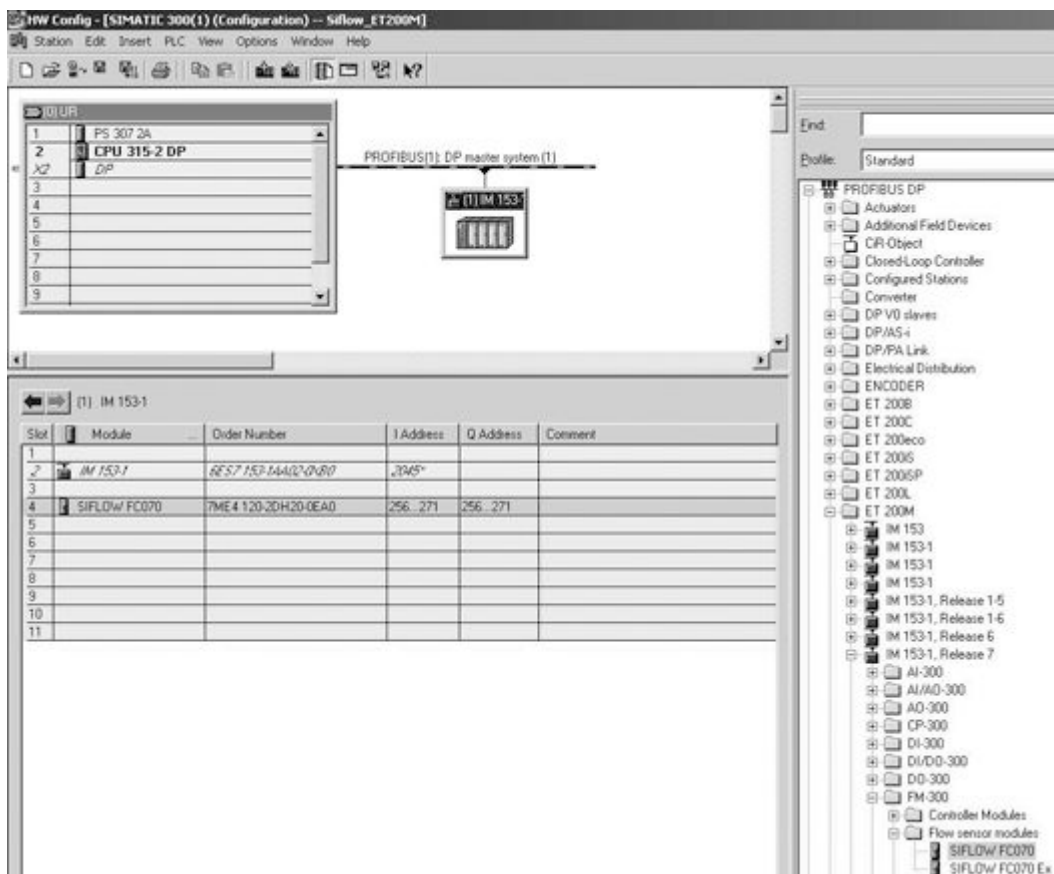

Figure 6-1 ET200M HW configuration (Profibus DP)

HW configuration in ET200M (Example for Profinet)

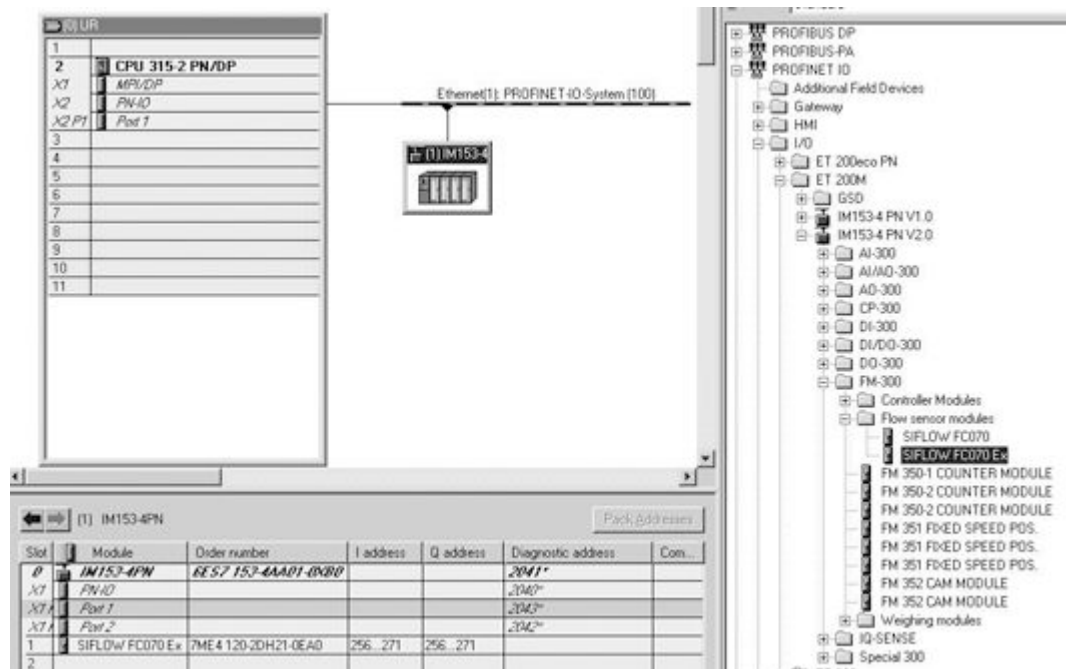

Figure 6-2 ET200M HW configuration (Profinet)

### HW configuration in S7-300 (CPU315-2-DP)

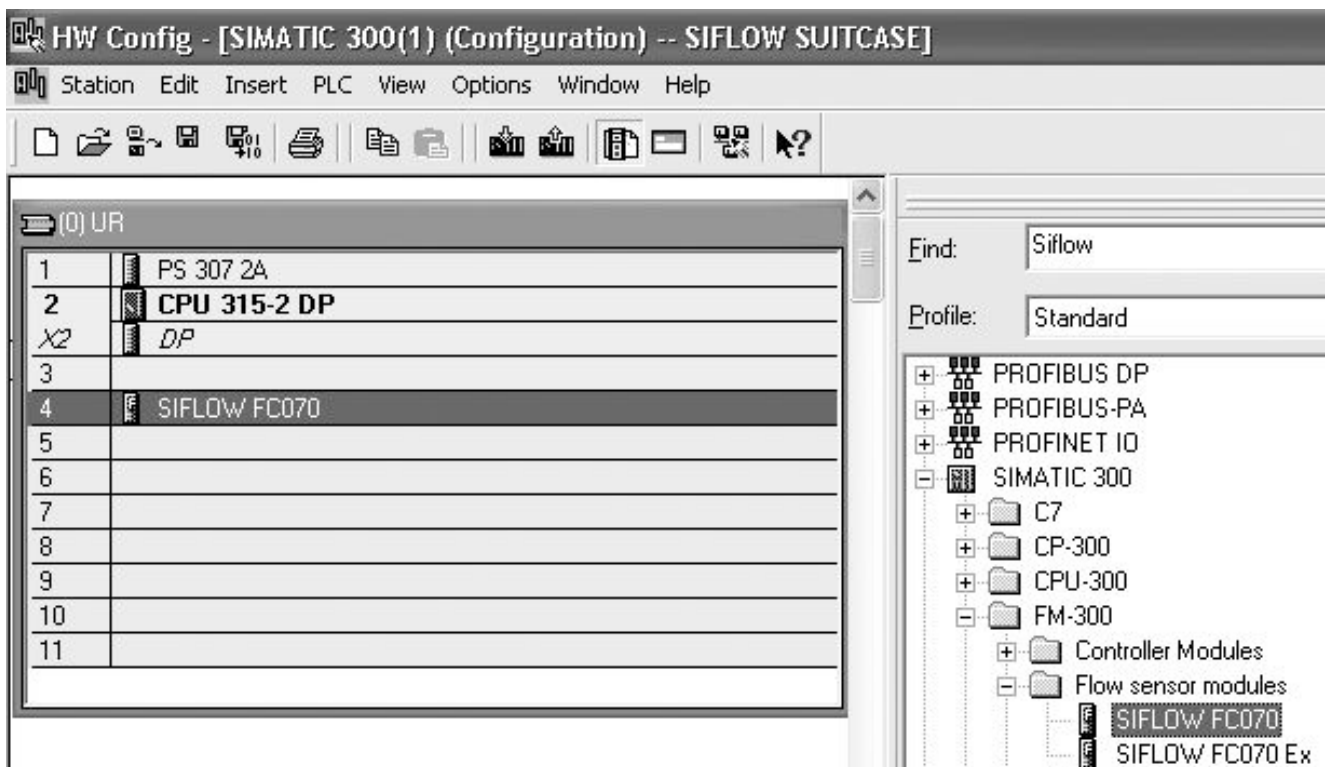

Figure 6-3 S7-300 HW Configuration

After the installation of the hardware update, the user GUI is available for setting the static basic parameters of the SIFLOW FC070 in the catalog profile "Standard".

## 6.3 PDM driver installation

### Note

For installation of PDM refer to the PDM manual.

The procedure for installing the PDM device driver consists of following steps:

- Download the update from the Internet, or copy it from the supplied CD into the envisaged folder and unzip the file
- Open "Manage Device Catalog" from Start → SIMATIC → SIMATIC PDM
- Navigate to the PDM device driver, select "SIFLOW FC070", click "OK", and the driver is installed on the PC

## Communication via the Serial Port

For communication via the serial port, set the transmission and receive buffer lengths to 1 byte ("low").

To make these settings, proceed as follows:

- Right-click on "My Computer" and select "Properties". Then select the following path: Hardware → Device Manager → Ports → COM 1 ... 8.
- Double-click on the appropriate port. Then select the following path: Port Settings → Advanced ....
- Set the receive buffer and transmission buffer to 1 byte ("low").

To accept the settings you have to restart the computer.

### Step-by-step guide for configuring PDM in SIMATIC Manager

The following configuration in SIMATIC Manager must be performed before the connection with SIFLOW FC070 is established.

1. Add the module to SIMATIC Modbus network:
  - Select "View" → "Process Device Network view".
  - Right click on "Net" and select "Insert New Object" → "Modbus Net".
  - Right click on "Modbus Net" and select "Insert New Object" → "Modbus Device".
  - Click on "Assign" and assign the Modbus device to SIFLOW FC070 (Sensor → Flow → Coriolis → SIEMENS → SIFLOW FC070 → "appropriate sensor type and size").
2. Set the COM-Port address:
  - Select the following path: Net → "Name of PC" → "COM Interface" and double-click on "COM Interface".
  - Select "Connection" and set the appropriate COM-Port.

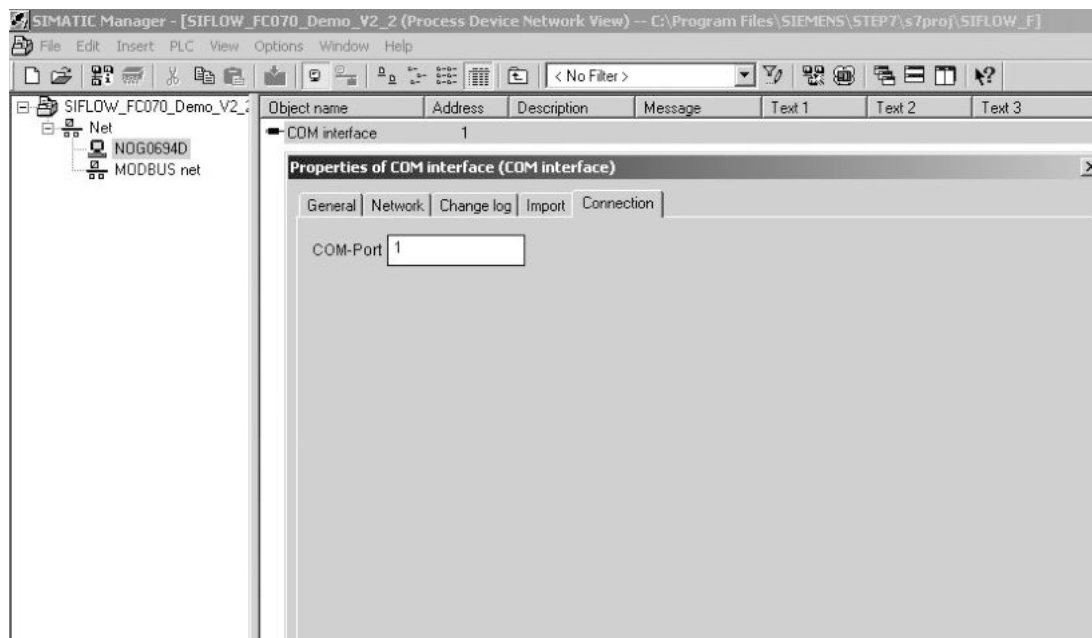

Figure 6-4 PDM Communication port setting

3. Set up the communication parameters for SIMATIC Modbus network.
  - Select "Net" → "Modbus net", right-click on "Modbus net" and select "Object Properties".
  - Select "Connection" and set the appropriate communication parameters (factory settings are indicated below).

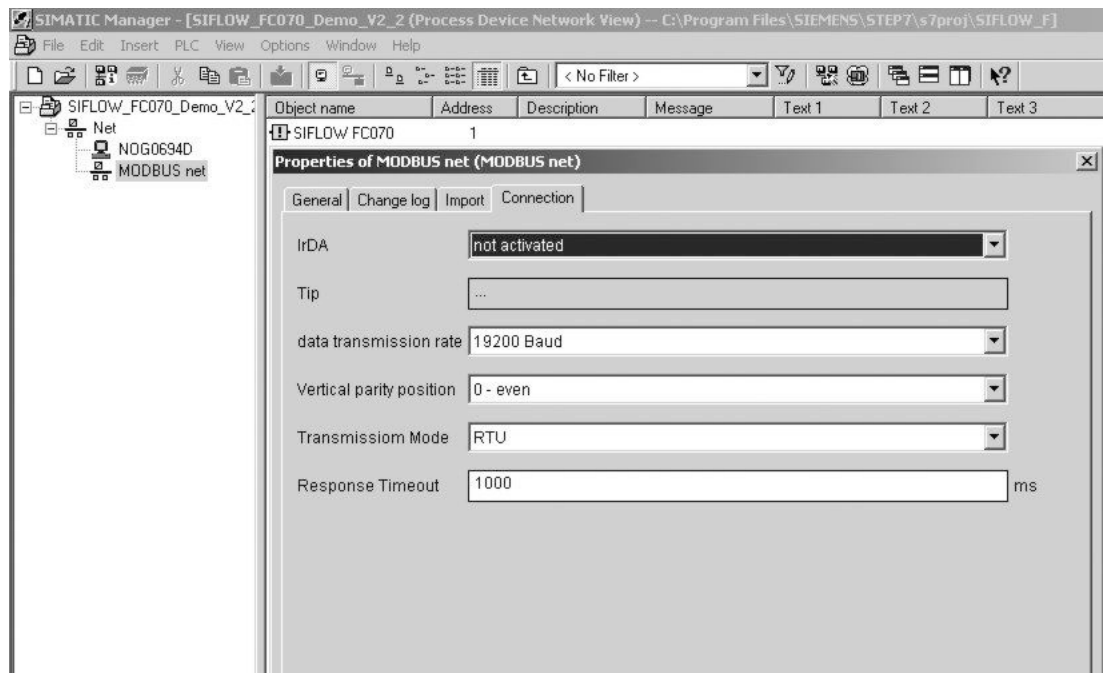

Figure 6-5 PDM communication setting

### Factory settings for Modbus communication

The following default settings have been made in the factory.

Parameter	Default setting
Slave device address	1
Data transmission rate	19 200
Vertical parity position	E-8-1 (0 - even)
Response timeout	10 000 ms
Response delay	1 ms
Interframe space	35

The settings can be changed via SIMATIC PDM or over the Modbus.

#### Note

The default slave device address (= 1) can only be changed by SIMATIC PCS 7 or SIMATIC PDM if the slave device address 0 is set on the DIP-switch on the function module. If an address between 1 and 247 is set on the DIP-switch, this address remains applicable and cannot be changed by SIMATIC S7 or SIMATIC PDM.

### See also

DIP switches (Page 33)





# Programming in SIMATIC S7

This chapter describes how to communicate with the function module by use of the S7 function blocks and data blocks provided with the module.

## 7.1 SIFLOW FC070 in the cyclic S7 program

Within the S7-300/400 automation system the data exchange takes place through FB95 SIFL\_FC function block supplied with the module.

The function block SIFL\_FC (FB95) is not present in the S7 block library, but is subsequently installed using a setup procedure described in chapter "Installation" (Page 49). In addition to the function block FB95, the setup contains:

- Online help for the function block
- Two associated data blocks DB\_FLOW\_PARA (DB17) and DB\_FLOW\_VEC (DB16)
- The user-defined data type UDT\_SIFL\_FC (UDT18)
- User documentation

### Function block and data block

The function block and the two data blocks in S7 provide you with a user interface to the sensors.

You insert the function block SIFL\_FC in the user program and write data to the inputs and outputs of the function block (call parameters). While programming the call, an instance data block is created for the FB SIFL\_FC. Besides the instance data block, a parameter DB (DB\_FLOW\_PARA) is required for every SIFLOW FC070, in which the parameters are stored. The UDT that comes with it can also be used for creating the parameter DB.

The vector DB (DB\_FLOW\_VEC) must also be loaded in the SIMATIC CPU. A vector DB can be used by more than one SIFLOW FC070.

### Reading parameters

Before any parameterization it is necessary to read all parameters from SIFLOW FC070 into the data block DB\_FLOW\_PARA, as the data block only contains default data and not sensor-specific data. Sensor-specific data are comprised in the SENSORPROM unit.

### SIFLOW FC070 in the HW Configuration

During project planning for the hardware configuration in the SIMATIC manager, the basic properties of the module are defined:

- The peripheral address of the module
- Diagnostic alarm enable
- Process alarm enable
- Behavior for CPU stop

The basic parameters are transferred to the function module during each restart and STOP/RUN transition of the CPU. Changes to parameters on the programming device must be compiled and written to the CPU.

## 7.2 Functions of the S7 function block SIFL\_FC (FB95)

The FB SIFL\_FC supports you during operation of the SIFLOW FC070 function module for industrial flow measurements according to the Coriolis principle. The following functions are offered:

- Read data record
- Write data record including handshake
- Select two readable process values
- Error queue with acknowledgment processing
- Synchronized indication of data and operating errors (after sending the command or data record to the function module)
- Write parameters using the block
- Send process commands including handshake
- Control both digital outputs
- Consistent reading back of the two selected process values and the status of the function module
- Start up synchronization
- Lifebit monitoring and controlling
- Protection against modifications (closed FB)
- Multi-instance capability

---

#### Note

The FB does not evaluate any diagnostics messages

---

## See also

- Error messages of SIFLOW FC070 (Page 151)
- Examples (Page 68)
- Data and operating errors (Page 156)
- Sensor errors (SE) and process errors (PE) (Page 152)

## 7.3 The data block DB\_FLOW\_PARA

### Requirement

When programming the call in the SIFL\_FC, an instance data block is created for the SIFL\_FC. In addition to the instance data block, a parameter data block DB\_FLOW\_PARA (DB17) is required for each SIFLOW FC070 function module, and the parameters for the flow measurement are stored in it. The provided UDT\_SIFL\_FC (UDT18) can be used to create the parameter DB.

In addition, the vector data block DB\_FLOW\_VEC (DB16) which contains the general structure of the DB\_FLOW\_PARA must be loaded in the S7 CPU. Only one DB\_FLOW\_VEC is required per S7 CPU.

### Basic functionality of data block DB\_FLOW\_PARA

The data block DB\_FLOW\_PARA contains the parameters and data provided for the flow measurements and combined in data records (DR).

All data records in the function block SIFL\_FC (FB95) which are read from the function module by means of command codes **200...399** and **600...649** are saved in the data block DB\_FLOW\_PARA.

All data records in the function block SIFL\_FC (FB95) which are written to the function module by means of command codes **400...599** and **650...699** are obtained from the data block DB\_FLOW\_PARA.

Data records 2 to 12 and 39 (parameters) can be read as well as written. Data records 30 to 37 (process data) can only be read from the function module.

In addition to the data records, the data block DB\_FLOW\_PARA also contains the call parameters of the function block SIFL\_FC (FB95). By linking the corresponding inputs and outputs of the FB and DB, it is possible for users to write the inputs of the FB with the current data from the DB when calling the FB, or to write the data from the FB into the DB.

NOTICE
You can change the contents (the parameter values) of the parameter DB, but not its length and structure.

**Calling parameters of the function block**

Using the call parameter CMD\_IN you can control all commands, whether for transmission of a data record or execution of a batch command. You provide the command code using this variable, and trigger the command by means of the variable CMD\_EN = 1. The FB SIFL\_FC does not delete the command code, but resets the trigger variable CMD\_EN after execution of the command.

**Set-up of SIFL\_FC (FB95) function block**

Data exchange with the SIFLOW FC070			
<p>SIFL_FC must be called once for every SIFLOW module in the hardware configuration. The ADDR is unique for every module. For every SIFL_FC there must also be a DB_FLOW_PARA</p> <p>DB_VECTOR exists only once in a system regardless of how many modules. The call shown is a typical configuration of SIFL_FC for most applications. It covers:</p> <ul style="list-style-type: none"> <li>Read and write of commands.</li> <li>Change of VAR1_VAL and VAR2_VAL</li> <li>Status information SC_STATUS (See also Error messages (Page 151) )</li> </ul>		<pre>                 "SIFL_                 DATA(Insta                 nceDB) "                 "SIFL_FC"                 EN          ENO                 256-ADDR    CMD_INPR "CMD_INPR"                 17-DB_PARA  CMD_FOK  "CMD_FOK"                 16-DB_VECTOR CMD_ERR  "CMD_ERR"                 "CMD_IN"   CMD_IN    "CMD_ERR_                 ... VAR_ADR    CMD_ERR_C "C"                 ... VAR_VAL    L_VAR_ADR ...                 ... VAR_VAL    L_VAR_VAL ...                 ... DIG_OUT    L_DIG_OUT ...                 "VAR1_ADR" VAR1_ADR  L_VAR1  "L_VAR_1_                 "VAR2_ADR" VAR2_ADR  ADR     ADR"                 "CMD_EN"   CMD_EN    L_VAR2  "L_VAR_2_                 "ERR_MSG_  ERR_MSG_Q VAR1_VAL "VAR1_VAL"                 Q          VAR2_VAL "VAR2_VAL"                 SC_STATUS "SC_                 VAR1_OK   ...                 VAR2_OK   ...                 ERR_MSG  "ERR_MSG"                 ERR_MSG_ "ERR_MSG_                 TYPE     TYPE"                 ERR_MSG_ "ERR_MSG_                 C       C"                 FE_ERR    ...                 FE_ERR_C  ...                 START_UP "START_UP"                 REF_COUNT ...             </pre>	

**Note**

You can find a detailed description of the individual call parameters of the function block as well as an example of a block call in the online help of the function block in S7.

Table 7-1 Call parameters of function block SIFL\_FC

Call parameter	Declaration	Data type	Description
ADDR	INPUT	INTEGER	Start address of SIFLOW FC070 function module, e.g. 280
DB_PARA	INPUT	INTEGER	Data block with FB call parameters up to DB offset 78, then SIFLOW FC data records. One DB_FLOW_PARA required per SIFLOW FC070 used. You can freely select the DB number.
DB_VECTOR	INPUT	INTEGER	Data block with vector information describing the structure of the DB_FLOW_PARA and special commands (600-699) which can only be evaluated by the FB. Only one DB_FLOW_VEC is required per SIMATIC CPU. You can freely select the DB number.

7.3 The data block DB\_FLOW\_PARA

Call parameter	Declaration	Data type	Description	
CMD_IN	INPUT	INTEGER	Command code to be executed	To prevent the command from being triggered more than once, the bit should be created as an edge
			<b>1..25</b>	SIFLOW commands are passed on directly to the module. See also SIFLOW commands (Page 193)
			<b>200..399</b>	Reading one of the data records 2..12, 30..37, 39 from the function module into the parameter data block DB_FLOW_PARA (CMD_IN = data record number + 200)
			<b>400..599</b>	Writing one of the data records 2..12, 39 from the parameter data block DB_FLOW_PARA into the function module (CMD_IN = data record number + 400)
			<b>600..649</b>	Reading of groups of data records from the function module into the parameter data block DB_FLOW_PARA
			600	Reading of sensor settings DR 3, 11, 31
			601	Reading of totalizer settings DR 4, 11
			602	Reading of batch settings DR 5, 11, 30, 31
			603	Reading of parameter DR 2, 3, 4, 5, 6, 7, 8, 9, 10, 11, 12, 30, 31, 32, 33, 34, 35, 36, 37, 39 and sending command CMD_PARA_CHANGE_ACK
			604	Reading of sensor settings DR 2, 3
			647	Reading of parameter DR 2, 3, 4, 5, 6, 7, 8, 9, 10, 11, 12, 39
			648	Reading of process data DR 30, 31, 32, 33, 34, 35, 36, 37
			649	Reading of all data records
			<b>650..699</b>	Reading of groups of data records from the parameter data block DB_FLOW_PARA into the function module.
			650	Write sensor settings DR 3, 11
			651	Write totalizer settings DR 4, 11
			652	Write batch settings DR 5, 11
			653	Write sensor settings DR 2, 3
			699	Writing of all parameter DR (DR 2, 3, 4, 5, 6, 7, 8, 9, 10, 11, 12, 39) from the parameter data block DB_FLOW_PARA into the function module.
			<b>700..704</b>	Importing of new values sent over the I/O interface.
			700	Importing of all new values sent over the I/O interface (VAR_ADR, VAR_VAL, DIG_OUT, VAR1_ADR, VAR2_ADR)
			701	Importing of new values for call parameters VAR_ADR and VAR_VAL
			702	Importing of new value for call parameter DIG_OUT
			703	Importing of new value for call parameter VAR1_ADR
			704	Importing of new value for call parameter VAR2_ADR

Call parameter	Declaration	Data type	Description
VAR_ADR	INPUT	INTEGER	Address of input variable *
VAR_VAL	INPUT	DWORD	Value of input variable
DIG_OUT	INPUT	DWORD	Digital output control
		Bit 0 / 1	ASIC control for output 1/2 disable: <ul style="list-style-type: none"> <li>0 = output is controlled by Coriolis ASIC (output and DO1 LED follow pulse, frequency or batch)</li> <li>1 = output control by Coriolis ASIC is disabled (control is switched to bits 2 and 3)</li> </ul>
		Bit 2 / 3	Status of output 1/2 with ASIC control disabled: <ul style="list-style-type: none"> <li>0 = off (switch open, no current, DO1 LED off)</li> <li>1 = on (switch closed, current, DO1 LED on)</li> </ul>
VAR1_ADR	INPUT	INTEGER	Address of output variable 1 *
VAR2_ADR	INPUT	INTEGER	Address of output variable 2 *
CMD_EN	IN/OUT	BOOL	Execution of command (CMD_IN): <ul style="list-style-type: none"> <li>1: start of command execution, FB automatically resets to 0 after execution of command</li> <li>0: procedure completed</li> </ul>
ERR_MSG_Q	IN/OUT	BOOL	User acknowledgment of error message to ERR_MSG_C: <ul style="list-style-type: none"> <li>1: error message acknowledgment</li> <li>0: no error message acknowledgment</li> </ul>
CMD_INPR	OUTPUT	BOOL	Command in progress: <ul style="list-style-type: none"> <li>1: procedure not yet completed</li> <li>0: procedure completed</li> </ul>
CMD_FOK	OUTPUT	BOOL	Command correctly executed (the bit is set for one cycle (edge) only): <ul style="list-style-type: none"> <li>1: command executed with error</li> <li>0: command executed without error</li> </ul>
CMD_ERR	OUTPUT	BOOL	Error during execution of command, indicates a synchronous error for exactly one cycle: <ul style="list-style-type: none"> <li>1: synchronous error present</li> <li>0: no synchronous error</li> </ul>
CMD_ERR_C	OUTPUT	BYTE	Static indication of last error code of a synchronous error (error during command execution). See table "Error information of function block SIFL_FC (Page 161)"
L_VAR_ADR	OUTPUT	INTEGER	Current address of input variable
L_VAR_VAL	OUTPUT	DWORD	Current value of input variable
L_DIG_OUT	OUTPUT	DWORD	Current digital output
L_VAR1_ADR	OUTPUT	INTEGER	Current address of output variable 1 *
L_VAR2_ADR	OUTPUT	INTEGER	Current address of output variable 2 *
VAR1_VAL	OUTPUT	DWORD	Value of output variable 1 (VAR1_ADR)
VAR2_VAL	OUTPUT	DWORD	Value of output variable 2 (VAR2_ADR)
SC_STATUS	OUTPUT	DWORD	Status of function module. See table "System status information (Page 162)"
VAR1_OK	OUTPUT	BOOL	VAR1_VAL is the current value of VAR1_ADR: <ul style="list-style-type: none"> <li>1: value of VAR1_VAL = VAR1_ADR</li> <li>0: value of VAR1_VAL ≠ VAR1_ADR</li> </ul>

7.3 The data block DB\_FLOW\_PARA

Call parameter	Declaration	Data type	Description
VAR2_OK	OUTPUT	BOOL	VAR2_VAL is the current value of VAR2_ADR: <ul style="list-style-type: none"> <li>• 1: value of VAR2_VAL = VAR2_ADR</li> <li>• 0: value of VAR2_VAL ≠ VAR2_ADR</li> </ul>
ERR_MSG	OUTPUT	BOOL	New error message present in the error queue: <ul style="list-style-type: none"> <li>• 1: error message present</li> <li>• 0: no error message</li> </ul>
ERR_MSG_TYPE	OUTPUT	BYTE	Type of error message in ERR_MSG_C; bit 0: no error <ul style="list-style-type: none"> <li>• bit 1: sensor error</li> <li>• bit 2: process error</li> <li>• bit 4: operator error</li> </ul>
ERR_MSG_C	OUTPUT	BYTE	Number of error message, must be acknowledged by user to ERR_MSG_Q. Following acknowledgment, the error message is deleted from the error queue. See table "Error information of function block SIFL_FC" (Page 161), table "Data and operator errors" (Page 156) and table "Sensor errors and process errors" (Page 152).
FB_ERR	OUTPUT	BOOL	Error not signaled by SIFLOW FC070 but detected by the FB itself. Is set for one cycle if a static error arrives or returns to normal. If a processing error occurs for FB SIFL_FC, we have to assume that the variables that have been output do not correspond with the actual status in the module. For number of FB error, see FB_ERR_C: <ul style="list-style-type: none"> <li>• 1: static error present</li> <li>• 0: no static error</li> </ul>
FB_ERR_C	OUTPUT	BYTE	Number of FB error: <ul style="list-style-type: none"> <li>• bit 0: DB_FLOW_PARA or DB_FLOW_VEC missing or with incorrect length</li> <li>• bit 1: error during internal call of SFB 52 or SFB 53, the value RET_VAL is written into DB_FLOW_PARA for one cycle</li> <li>• bit 2: error during interpretation of a data record/command, specified data record or command number is incorrect</li> <li>• bit 3: lifebit error, SIFLOW FC070 does not reply</li> <li>• bit 4: I/O input data could not be read out even following three attempts</li> <li>• bit 5: activated command was aborted during restart</li> <li>• bit 6: reserved</li> <li>• bit 7: reserved</li> </ul>
START_UP	OUTPUT	BOOL	Startup of function module: <ul style="list-style-type: none"> <li>• 1: procedure not yet completed</li> <li>• 0: procedure completed</li> </ul>
REF_COUNT	OUTPUT	BYTE	Refresh counter: REF_COUNT is incremented by SIFLOW FC070 each time the data of the function module are updated. The FB uses the REF_COUNT for a consistency check over the complete 16-byte area of the function module data.

\* The addresses of the call parameters (L\_)VAR\_ADR, (L\_)VAR1\_ADR, (L\_)VAR2\_ADR are MODBUS addresses.



**See also**

Functions of the S7 function block SIFL\_FC (FB95) (Page 58)

Additional parameters in data block DB\_FLOW\_PARA (Page 66)

**7.4 Functions of data block DB\_FLOW\_VEC**

The vector data block DB\_FLOW\_VEC (DB16) contains the pointers to the data records in the DB\_FLOW\_PARA and the commands entered there which are to be executed.

You need only download the vector DB into the S7 CPU so that the FB SIFL\_FC can use the information entered there. The vector DB is irrelevant for the further creation of your user program because the program accesses the CPU memory area using a symbolic access function.

**NOTICE**

Do not change the content, length and structure of the vector DB.

It need only be loaded once for each S7 CPU, independent of the number of SIFLOW FC070 function modules deployed.

You can freely select the number of the DB\_FLOW\_VEC.

**7.5 Data records in data block DB\_FLOW\_PARA**

DR No.	Contents	Read/write	Description
<b>Commands</b>			
	DB_Length		Length of the DB
	Max. lifebit cycle		Lifebit monitoring
	SFB error code		Communication error code of SFB52 / SFB53
	All call parameters of FB95		See Step 1: Reading parameters into DB17 (DB_FLOW_PARA) (Page 85)
<b>Parameters</b>			
2	Units	R / W	Settings for units
3	Basic parameter	R / W	Settings for basic settings
4	Totalizer parameter	R / W	Settings for totalizer 1 and 2
5	Digital output parameter	R / W	Settings for digital output
6	Digital input parameter	R / W	Settings for digital input
7	COM interface parameter	R / W	Settings for P-bus and RS 485 interface
8	Date & time parameter	R / W	Settings for date and time

7.6 Additional parameters in data block DB\_FLOW\_PARA

DR No.	Contents	Read/write	Description
9	Sensor characteristic parameter	R / W	Settings for sensor properties
10	Simulation parameter	R / W	Settings for simulation values
11	Process preset parameter	R / W	Setting for process default settings
12	Limit parameter	R / W	Settings for limit default settings
39	CT parameter	R / W	Settings for CT parameter
<b>Process, service, product data</b>			
30	Flowmeter process information	R	Current process data
31	Service information	R	Service information data
32	Transmitter information	R	Transmitter data
33	Sensor information	R	Sensor data
34	Customer information	R	Customer data
35	MODBUS ID information	R	MODBUS data
36	MODBUS service information	R	MODBUS data
37	CT values	R	CT data

**Note**

The data records listed above are described in detail in the following sections. Please note that the min./max. values integrated in the tables for better clarity are present in separate data records. The relationship between a data record and its associated min./max. values is as follows:

- min. values: DR No. + 40 corresponds to the associated "Min." data record;
- max. values: DR No. + 80 corresponds to the associated "Max." data record.

Example: for data record 4, the min. values are in DR 44, and the max. values in DR 84.

The min./max. values are only module-internal values, i.e. the user program has no access to the min./max. data records.

## 7.6 Additional parameters in data block DB\_FLOW\_PARA

Table 7-2 Parameters in data block DB\_FLOW\_PARA

Offset in the DB	Offset in the DR	Symbolic name	Data type	Description
0.0	0.0	i_DB_Length	INT	Length of the DB
2.0	2.0	i_MaxLifeBitCyc	INT	Lifebit monitoring
4.0	4.0	w_SFC_ERR_C	WORD	Communication error code of SFB52/53
6.0	6.0	i_CMD_INPUT	INT	Command code to be executed
8.0	8.0	i_VAR_ADRESS	INT	Address of input variable
10.0	10.0	d_VAR_VALUE	DWORD	Value of input variable
14.0	14.0	w_DIG_OUTPUT	WORD	Digital output control
16.0	16.0	i_VAR1_ADR	INT	Address of output variable 1

## 7.6 Additional parameters in data block DB\_FLOW\_PARA

Offset in the DB	Offset in the DR	Symbolic name	Data type	Description
18.0	18.0	i_VAR2_ADR	INT	Address of output variable 2
20.0	20.0	b_CMD_ERR_CODE	BYTE	Error executing the command
21.0	21.0	b_REFRESH_COUNTER	BYTE	Refresh counter
22.0	22.0	d_VAR1_VALUE	DWORD	Value of output variable 1
26.0	26.0	d_VAR2_VALUE	DWORD	Value of output variable 2
30.0	30.0	i_LAST_VAR_ADR	INT	Current address of input variable
32.0	32.0	d_LAST_VAR_VALUE	DWORD	Current value of input variable
36.0	36.0	w_LAST_DIGITAL_OUT	WORD	Current digital output
38.0	38.0	i_LAST_VAR1_ADR	INT	Current address of output variable 1
40.0	40.0	i_LAST_VAR2_ADR	INT	Current address of output variable 2
42.0	42.0	d_SC_STATUS	DWORD	Status of function module
46.0	46.0	b_ERR_MSG_TYPE	BYTE	Type of error message from function module
47.0	47.0	b_ERR_MSG_CODE	BYTE	Number of error message from function module
48.0	48.0	b_FB_ERR_CODE	BYTE	Number of FB error
49.0	49.0	bo_CMD_IN_PROGRESS	BOOL	Command is being executed
49.1	49.1	bo_CMD_FINISHED_OK	BOOL	Command correctly executed
49.2	49.2	bo_CMD_ERR	BOOL	Error executing the command
49.3	49.3	bo_VAR1_OK	BOOL	VAR1_VAL is the current value of VAR1_ADR
49.4	49.4	bo_VAR2_OK	BOOL	VAR2_VAL is the current value of VAR2_ADR
49.5	49.5	bo_FB_ERR	BOOL	Error detected by the FB itself.
49.6	49.6	bo_ERR_MSG	BOOL	New error message present
49.7	49.7	bo_START_UP_IN_PROGRESS	BOOL	Startup of function module
50.0	50.0	bo_CMD_ENABLE	BOOL	Execution of the command
50.1	50.1	bo_ERR_MSG_QUIT	BOOL	User acknowledgment of error message
52.0	52.0	s_CMD1	STRUCT	Command input 1
52.0	0.0	i_CMD1_Code	INT	Command code
54.0	2.0	bo_CMD1_Trigger	BOOL	Command enable
54.1	2.1	bo_CMD1_InProgress	BOOL	Command is being executed
54.2	2.2	bo_CMD1_FinishedOk	BOOL	Command correctly executed
54.3	2.3	bo_CMD1_FinishedError	BOOL	Error executing the command
56.0	56.0	s_CMD2	STRUCT	Command input 2
56.0	0.0	i_CMD2_Code	INT	Command code
58.0	2.0	bo_CMD2_Trigger	BOOL	Command enable
58.1	2.1	bo_CMD2_InProgress	BOOL	Command is being executed
58.2	2.2	bo_CMD2_FinishedOk	BOOL	Command correctly executed
58.3	2.3	bo_CMD2_FinishedError	BOOL	Error executing the command
60.0	60.0	s_CMD3	STRUCT	Command input 3
60.0	0.0	i_CMD3_Code	INT	Command code
62.0	2.0	bo_CMD3_Trigger	BOOL	Command enable
62.1	2.1	bo_CMD3_InProgress	BOOL	Command is being executed
62.2	2.2	bo_CMD3_FinishedOk	BOOL	Command correctly executed

7.7 Examples

Offset in the DB	Offset in the DR	Symbolic name	Data type	Description
62.3	2.3	bo_CMD3_FinishedError	BOOL	Error executing the command
64.0	64.0	w_DB_RES89	WORD	
66.0	66.0	w_DB_RES90	WORD	
68.0	68.0	w_DB_RES91	WORD	
70.0	70.0	w_DB_RES92	WORD	
72.0	72.0	w_DB_RES93	WORD	
74.0	74.0	w_DB_RES94	WORD	
76.0	76.0	w_DB_RES95	WORD	
78.0	78.0	w_OCX_WRITE_DATA	WORD	OCX write data (Random / control number)

## 7.7 Examples

### 7.7.1 Read out process values for massflow and totalizer 2

Table 7-3 Set massflow on output VAR1\_VAL

STL	
CALL FB95,DB195	Call the FB "SIFL_FC" with instance DB 195 (e.g. )
ADDR := 280	Start address of SIFLOW FC070 (e.g.)
DB_FLOW_PARA :=17	Parameter data block number
DB_FLOW_VEC :=16	Vector data block number
CMD_IN :=703	Command to be executed, here: Load address 3000 on output L_VAR1_ADR
VAR_ADR :=	not relevant
VAR_VAL :=	not relevant
DIG_OUT :=	not relevant
VAR1_ADR := 3000	MODBUS address for massflow
VAR2_ADR :=	not relevant
CMD_INPR :=	1=Command in progress
CMD_FOK :=	1=Command executed correctly
CMD_ERR :=	1=Command was not executed
CMD_ERR_C :=	Error code for command not executed
REF_COUNT :=	not relevant
VAR1_VAL :=	Value that was read from L_VAR1_ADR
VAR2_VAL :=	not relevant
L_VAR_ADR :=	not relevant
L_VAR_VAL :=	not relevant
L_DIG_OUT :=	not relevant
L_VAR1_ADR :=	Value that was read from VAR1_VAL

STL	
L_VAR2_ADR :=	not relevant
SC_STATUS :=	not relevant
ERR_MSG :=	1=New error message present
ERR_MSG_TYPE :=	0: No error; 1, 2, 4=Type of error message
ERR_MSG_C :=	Number of error message
FB_ERR :=	FB error
FB_ERR_C :=	Number of FB error
START_UP :=	not relevant
VAR1_OK :=	1=If VAR1_ADR = L_VAR1_ADR
VAR2_OK :=	1=If VAR2_ADR = L_VAR2_ADR
CMD_EN :=1	1=Execution of command CMD_IN
ERR_MSG_Q :=	1=User acknowledgment of error message to ERR_MSG_C

On successful completion of command 703, the massflow is now available on output VAR1\_VAL and address 3000 is on output L\_VAR1\_ADR. Also VAR1\_OK = 1 because VAR1\_ADR and L\_VAR1\_ADR are now equal.

Table 7-4 Set Totalizer 2 on output VAR2\_VAL

STL	
CALL FB95,DB195	Call the FB "SIFL_FC" with instance DB 195 (e.g. )
ADDR := 280	Start address of SIFLOW FC070 (e.g.)
DB_FLOW_PARA :=17	Parameter data block number
DB_FLOW_VEC :=16	Vector data block number
CMD_IN :=704	Command to be executed, here: Load address 3024 on output L_VAR2_ADR
VAR_ADR :=	not relevant
VAR_VAL :=	not relevant
DIG_OUT :=	not relevant
VAR1_ADR := 3000	MODBUS address for massflow
VAR2_ADR := 3024	MODBUS address for Totalizer 2
CMD_INPR :=	1=Command in progress
CMD_FOK :=	1=Command executed correctly
CMD_ERR :=	1=Command was not executed
CMD_ERR_C :=	Error code for command not executed
REF_COUNT :=	not relevant
VAR1_VAL :=	Massflow
VAR2_VAL :=	Value that was read from L_VAR2_ADR
L_VAR_ADR :=	not relevant
L_VAR_VAL :=	not relevant
L_DIG_OUT :=	not relevant
L_VAR1_ADR := 3000	MODBUS address for massflow

7.7 Examples

STL	
L_VAR2_ADR :=	Value that was read from VAR1_VAL
SC_STATUS :=	not relevant
ERR_MSG :=	1=New error message present
ERR_MSG_TYPE :=	0: No error; 1, 2, 4=Type of error message
ERR_MSG_C :=	Number of error message
FB_ERR :=	FB error
FB_ERR_C :=	Number of FB error
START_UP :=	not relevant
VAR1_OK := 1	1=If VAR1_ADR = L_VAR1_ADR
VAR2_OK :=	1=If VAR2_ADR = L_VAR2_ADR
CMD_EN :=1	1=Execution of command CMD_IN
ERR_MSG_Q :=	1=User acknowledgment of error message to ERR_MSG_C

On successful completion of command 704, the value of Totalizer 2 is now available on output VAR2\_VAL and address 3024 is on output L\_VAR2\_ADR. Also VAR2\_OK = 1 because VAR2\_ADR and L\_VAR2\_ADR are now equal.

### 7.7.2 Reset totalizer 2

After massflow and Totalizer 2 have been read out, Totalizer 2 should now be reset.

Table 7-5 Reset totalizer 2

STL	
CALL FB95,DB195	Call the FB "SIFL_FC" with instance DB 195 (e.g. )
ADDR := 280	Start address of SIFLOW FC070 (e.g.)
DB_FLOW_PARA :=	17 parameter data block number
DB_FLOW_VEC :=	16 Vector data block number
CMD_IN :=	10 Command to be executed, here: Resetting Totalizer 2
VAR_ADR :=	not relevant
VAR_VAL :=	not relevant
DIG_OUT :=	not relevant
VAR1_ADR :=	3000 MODBUS address of massflow
VAR2_ADR :=	3024 MODBUS address for Totalizer 2
CMD_INPR :=	1=Command in progress
CMD_FOK :=	1=Command executed correctly
CMD_ERR :=	1=Command was not executed
CMD_ERR_C :=	Error code for command not executed
REF_COUNT :=	not relevant
VAR1_VAL :=	Massflow
VAR2_VAL :=	Totalizer 2
L_VAR_ADR :=	not relevant

STL	
L_VAR_VAL :=	not relevant
L_DIG_OUT :=	not relevant
L_VAR1_ADR :=	3000 MODBUS address of massflow
L_VAR2_ADR :=	3024 MODBUS address for Totalizer 2
SC_STATUS :=	not relevant
ERR_MSG :=	1=New error message present
ERR_MSG_TYPE :=	0: No error; 1, 2, 4=Type of error message
ERR_MSG_C :=	Number of error message
FB_ERR :=	FB error
FB_ERR_C :=	Number of FB error
START_UP :=	not relevant
VAR1_OK := 1	1=If VAR1_ADR = L_VAR1_ADR
VAR2_OK := 1	1=If VAR2_ADR = L_VAR2_ADR
CMD_EN :=1	1=Execution of command CMD_IN
ERR_MSG_Q :=	1=User acknowledgment of error message to ERR_MSG_C

Following successful execution of command 10, Totalizer 2, which was previously set to output VAR2\_VAL, is reset to 0.

### 7.7.3 Initialize batch mode

First all data records are read (DR2-12 and DR30-36, DR37 and DR39).

Table 7-6 Read all data records

STL	
CALL FB95,DB195	Call the FB "SIFL_FC" with instance DB 195 (e.g. )
ADDR := 280	Start address of SIFLOW FC070 (e.g.)
DB_FLOW_PARA :=	17 parameter data block number
DB_FLOW_VEC :=	16 Vector data block number
CMD_IN :=649	Command to be executed, here: Read all data records
VAR_ADR :=	not relevant
VAR_VAL :=	not relevant
DIG_OUT :=	not relevant
VAR1_ADR :=	3000 MODBUS address for massflow
VAR2_ADR :=	3024 MODBUS address for Totalizer 2
CMD_INPR :=	1=Command in progress
CMD_FOK :=	1=Command executed correctly
CMD_ERR :=	1=Command was not executed
CMD_ERR_C :=	Error code for command not executed
REF_COUNT :=	not relevant
VAR1_VAL :=	Massflow

7.7 Examples

STL	
VAR2_VAL :=	Totalizer 2
L_VAR_ADR :=	not relevant
L_VAR_VAL :=	not relevant
L_DIG_OUT :=	not relevant
L_VAR1_ADR :=	3000 MODBUS address for massflow
L_VAR2_ADR :=	3024 MODBUS address for Totalizer 2
SC_STATUS :=	not relevant
ERR_MSG :=	1=New error message present
ERR_MSG_TYPE :=	0: No error; 1, 2, 4=Type of error message
ERR_MSG_C :=	Number of error message
FB_ERR :=	FB error
FB_ERR_C :=	Number of FB error
START_UP :=	not relevant
VAR1_OK := 1	1=If VAR1_ADR = L_VAR1_ADR
VAR2_OK := 1	1=If VAR2_ADR = L_VAR2_ADR
CMD_EN :=1	1=Execution of command CMD_IN
ERR_MSG_Q :=	1=User acknowledgment of error message to ERR_MSG_C

Then settings are made in the data records for batch operation.

```

//Set output to Batch
L      6
T      "DB_FLOW_PARA".s_DigitalOutputParam.b_Dig_out_func
//Set Batch to massflow
//Increment batch counter
//LED DO1 should be lit while batch is running
L      1
T      "DB_FLOW_PARA".s_DigitalOutputParam.b_Batch_val_sel
T      "DB_FLOW_PARA".s_DigitalOutputParam.b_Batch_count_up_down
T      "DB_FLOW_PARA".s_DigitalOutputParam.b_Batch_output_polarity
//Deactivate time error monitoring
//Deactivate batch overflow monitoring
L      0
T      "DB_FLOW_PARA".s_DigitalOutputParam.b_Batch_time_err_on_off
T      "DB_FLOW_PARA".s_DigitalOutputParam.b_Batch_ouerrun_on_off
//Set batch quantity
L      1.000000e+000
T      "DB_FLOW_PARA".s_ProcessPresetParam.r_Batch_quantity
//Batch compensation, set lead constant and Stage 2 level to 0
// (default)
L      0.000000e+000
T      "DB_FLOW_PARA".s_ProcessPresetParam.r_Batch_compens

```



```
T      "DB_FLOW_PARA".s_ProcessPresetParam.r_Batch_lead_const
T      "DB_FLOW_PARA".s_ProcessPresetParam.r_Batch_two_stage_lev
```

The changed data must now be loaded from the function module, so that all data records will be written (DR2-12, and DR39).

Table 7-7 Write all data records

STL	
CALL FB95,DB195	Call the FB "SIFL_FC" with instance DB 195 (e.g. )
ADDR := 280	Start address of SIFLOW FC070 (e.g.)
DB_FLOW_PARA :=17	Parameter data block number
DB_FLOW_VEC :=16	Vector data block number
CMD_IN :=699	Command to be executed, here: Write all data records
VAR_ADR :=	not relevant
VAR_VAL :=	not relevant
DIG_OUT :=	not relevant
VAR1_ADR := 3000	MODBUS address for massflow
VAR2_ADR := 3024	MODBUS address for Totalizer 2
CMD_INPR :=	1=Command in progress
CMD_FOK :=	1=Command executed correctly
CMD_ERR :=	1=Command was not executed
CMD_ERR_C :=	Error code for command not executed
REF_COUNT :=	not relevant
VAR1_VAL :=	Massflow
VAR2_VAL :=	Totalizer 2
L_VAR_ADR :=	not relevant
L_VAR_VAL :=	not relevant
L_DIG_OUT :=	not relevant
L_VAR1_ADR := 3000	MODBUS address for massflow
L_VAR2_ADR := 3024	MODBUS address for Totalizer 2
SC_STATUS :=	not relevant
ERR_MSG :=	1=New error message present
ERR_MSG_TYPE :=	0: No error; 1, 2, 4=Type of error message
ERR_MSG_C :=	Number of error message
FB_ERR :=	FB error
FB_ERR_C :=	Number of FB error
START_UP :=	not relevant
VAR1_OK := 1	1=If VAR1_ADR = L_VAR1_ADR
VAR2_OK := 1	1=If VAR2_ADR = L_VAR2_ADR
CMD_EN :=1	1=Execution of command CMD_IN
ERR_MSG_Q :=	1=User acknowledgment of error message to ERR_MSG_C

The batch can now be started with Command 1.

Table 7-8 Start batch

STL	
CALL FB95,DB195	Call the FB "SIFL_FC" with instance DB 195 (e.g. )
ADDR := 280	Start address of SIFLOW FC070 (e.g.)
DB_FLOW_PARA :=	17 parameter data block number
DB_FLOW_VEC :=	16 Vector data block number
CMD_IN :=1	Command to be executed, here: Start batch
VAR_ADR :=	not relevant
VAR_VAL :=	not relevant
DIG_OUT :=	not relevant
VAR1_ADR :=	3000 MODBUS address for massflow
VAR2_ADR :=	3024 MODBUS address for Totalizer 2
CMD_INPR :=	1=Command in progress
CMD_FOK :=	1=Command executed correctly
CMD_ERR :=	1=Command was not executed
CMD_ERR_C :=	Error code for command not executed
REF_COUNT :=	not relevant
VAR1_VAL :=	Massflow
VAR2_VAL :=	Totalizer 2
L_VAR_ADR :=	not relevant
L_VAR_VAL :=	not relevant
L_DIG_OUT :=	not relevant
L_VAR1_ADR :=	3000 MODBUS address for massflow
L_VAR2_ADR :=	3024 MODBUS address for Totalizer 2
SC_STATUS := MD100	Status of module
ERR_MSG :=	1=New error message present
ERR_MSG_TYPE :=	0: No error; 1, 2, 4=Type of error message
ERR_MSG_C :=	Number of error message
FB_ERR :=	FB error
FB_ERR_C :=	Number of FB error
START_UP :=	not relevant
VAR1_OK := 1	1=If VAR1_ADR = L_VAR1_ADR
VAR2_OK := 1	1=If VAR2_ADR = L_VAR2_ADR
CMD_EN :=1	1=Execution of command CMD_IN
ERR_MSG_Q :=	1=User acknowledgment of error message to ERR_MSG_C

LED DO1 is lit while the batch is running.

The progress of the batch procedure is indicated on output VAR2\_VAL. When Totalizer 2 on output VAR2\_VAL reaches the batch quantity, LED DO1 is switched off. The current massflow remains on output VAR1\_VAL.

This means that the total time for the batch procedure can be calculated from the following formula:  $T = \text{Batch quantity} / \text{massflow}$

The status bit ST\_BATCHING also remains set for the duration of the batch procedure.

This can be determined as follows:

```
L      MD      100
L      1
AD
L      1
==D
S      A      0.0
TAK
L      0
==D
R      A      0.0
```

When the ST\_BATCHING status bit is active, Output 0.0 of a digital output module is set.



# Commissioning with SIMATIC PDM

## 8.1 General instructions

SIMATIC PDM is a software package for configuring, parameterizing, commissioning and maintaining devices (e.g. transducers) and for configuring networks and PCs.

Among other features, SIMATIC PDM contains a simple process monitoring of the process values, interrupts and status/diagnosis signals of the device.

### Requirements

The following procedures must be completed before commissioning:

- Installation of SIMATIC PDM and SIFLOW FC070 PDM driver. (See also "Installation" (Page 52)).
- Connection of Modbus interface. (See also "Connecting" (Page 45)).

### Step-by-step guide to commissioning with PDM

The following steps show an example of how commissioning the SIFLOW FC070 can be performed.

#### NOTICE

The example only covers measurement of massflow, but equal parameters exist for all other measurements.

The steps are divided into the following sections:

1. Configuration describes the setup of the basic parameters of the flowmeter. Step 1 in this section (read all parameters from SIFLOW) must be carried out before changing any parameters.
2. System optimization describes how to optimize the system to gain better performance and precision. This section must be performed if an optimization of the system is needed.
3. Operation describes how to view all available process values.

Step	Description	Section
STEP 1	Reading all parameters from the SIFLOW into the DB_FLOW_PARA	CONFIGURATION
STEP 2	Setting basic parameters in SIFLOW	
STEP 3	Zero point adjustment	SYSTEM OPTIMIZATION
STEP 4	View process variable	OPERATION

## 8.2 Step 1: Reading parameters from SIFLOW FC070

Before any parameterization is done it is necessary to read all parameters from the SIFLOW module into the offline table of SIMATIC PDM. This is necessary because the offline table merely contains default data.

1. Open the PDM device driver.
2. Select "Device->Upload to PC/PG .." Select "Execute even if the device TAG does not match the project data TAG." and click "OK" to read all parameters to the offline table. After closing the dialog all loaded parameters should show "Loaded" in the status of the PDM table.

## 8.3 Step 2: Setting basic parameters

In any application, the following must be defined before the parameters are configured:

- Measurement range of the application (min - max)
- Unit for the measurement range

Depending on the application, measurement range and measurement units, the following parameters may need to be changed:

- Massflow unit
- Massflow upper value
- Massflow lower value

### Example

- Measurement units must be kg/h
- Mass flow upper value must be 250 kg/h.
- Mass flow min must be 0 kg/h.

The following screen print shows the changes in the PDM table:

Parameter	Value	Unit
» » » Mass Flow		
Unit	kg/h	
Lower Range Value	0,000000	kg/h
Upper Range Value	20,000000	kg/h
Sensor: Lower Limit	0	kg/h
Sensor: Upper Limit	125	kg/h

### Setting the basic parameters

1. Change the settings of the measurement parameters in the Output → Mass Flow folder (see above) to appropriate values.
2. Select: "Device → Download to device...".
3. Select "Execute even if the device TAG does not match the project data TAG" and click "OK" to download all parameters from the table to the device.

---

#### Note

If the SF LED on the SIFLOW module is red, a system failure has occurred.

Refer to the chapter "Troubleshooting/FAQs" (Page 171) and make sure the problem is resolved before continuing the commissioning.

---

## 8.4 Step 3: System optimization

The flowmeter system is optimized through a zero point adjustment.

### Performing a zero point adjustment

1. Install shut-off devices in the pipeline. If possible, both upstream and downstream of the sensor. Otherwise:
  - in horizontal installations at the outlet
  - in vertical installations at the inlet.
2. Pump liquid at max. flow through the sensor (at least 2 min) in order to avoid air in the liquid.
3. Stop the flow while pumping by shutting off the outlet valve and then the inlet valve. Wait at least 1 min. In this way there will be zero flow but the liquid remains pressurized within the sensor, hindering de-gassing of the liquid, i.e. the release of air or other gas from the liquid.

---

#### Note

The flow must be completely stopped and the sensor completely filled with liquid.

---

4. Select "Device → Zero adjust" from the main menu of SIMATIC PDM to perform an automatic zero point adjustment.  
An online menu will appear where appropriate parameters can be configured and automatic zero point adjustment performed.
5. Start the zero point adjustment by clicking "Auto zero adjust". When the zero point adjustment has finished, a message box will show the result of the zero point adjustment.

---

#### Note

If you get an error message after the zero point adjustment, refer to the chapter "Troubleshooting/FAQs" (Page 171).

---

### 8.5 Step 4: View process variables

The system is now ready for normal operation.

1. Select "View->Display" to see all process values.
2. Verify that the process values show the expected values.

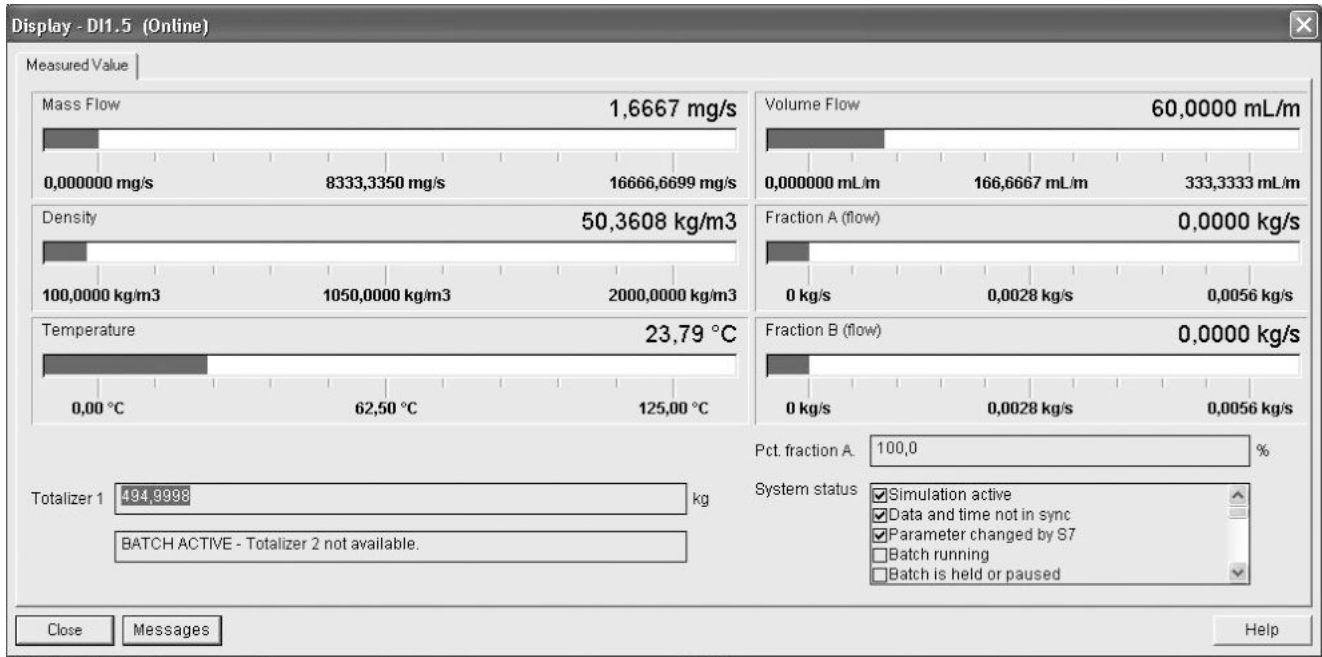

Figure 8-1 PDM Process values



## Commissioning with SIMATIC S7

This chapter provides a step-by-step guide on how to make the initial set-up of SIFLOW FC070 non-Ex and Ex in a S7-300/400 environment.

The chapter refers to a PLC example code from SIFLOW getting started package found on the CD provided with the product.

After finishing the steps, the system is ready to go into normal operation.

---

### Note

The steps described within this chapter must always be carried out regardless of the application intended.

---

### Requirements

It is assumed that the user is familiar with the SIMATIC Manager environment and has carried out the steps mentioned below:

- Installed the measurement system consisting of a SIFLOW FC070 and a sensor. (See "Hardware installation and removal (Page 29)")
- Installed the S7 library. (See "Software installation (Page 49)")
- Installed the HSP package. (See Software installation (Page 49))

## 9.1 Setting the basic parameters in the HW-Config

Set the static basic parameters as follows:

Add SIFLOW FC070 module to the HW config by dragging and dropping the module into the rail with S7-300 CPU or ET-200M (see Installation of S7 Hardware support package (Page 49)).

1. Select SIFLOW function module in HW-Config, and then the menu command Edit > Object properties.
2. In the Basic parameters tab, enter the following static basic parameters.

9.1 Setting the basic parameters in the HW-Config

Table 9-1 Static basic parameters of SIFLOW FC070

Basic parameters	Value range	Default	Range of action
Interrupt generation	<ul style="list-style-type: none"> <li>• Yes</li> <li>• No</li> </ul>	No	Function module
Select Interrupt	<ul style="list-style-type: none"> <li>• None</li> <li>• Diagnostics</li> <li>• Process</li> <li>• Diagnostics + process</li> </ul>	Diagnostics + process	
Reaction to CPU STOP	<ul style="list-style-type: none"> <li>• Both outputs deactivated</li> <li>• Only output 1 activated</li> <li>• Only output 2 activated</li> <li>• Both outputs activated</li> <li>• No reaction</li> </ul>	No reaction	
Device address*	1 ... 247	1	

\* Only used if the DIP switch setting of the function module address is = 0

**Note**

Make sure that you assign identical values to the start addresses of the output and input data areas for each SIFLOW FC070.

**Note**

Make sure that you assign a different device address to each function module if several modules are used in the rack or on the MODBUS.

**Diagnostics interrupt**

If you enable the diagnostics interrupt, any diagnostics information present is entered into the diagnostics data record and triggers a diagnostics interrupt (OB82).

**Process interrupts**

If you enable the process interrupts, you can parameterize 8 process interrupts in data record 7. Certain events in the process trigger a process alarm, e.g. upward or downward violation of a limit, and the OB40 is called.

**Note**

If the parameter "Interrupt generation" is set to "No", the parameter "Interrupt selection" has no effect.

## 9.2 Step-by-step guide to commissioning with S7

The following step-by-step example refers to the demo software provided with the getting started package.

In the example it is assumed that:

- The sensor is an FC300 DN 4
- The SIFL\_FC S7 library is used "as is" (no renaming of FB's and DB's)
  - FB95 = SIFL\_FC
  - DB17 = DB\_FLOW\_PARA
  - DB16 = DB\_FLOW\_VECTOR

**Note**

The example only covers measurement of mass flow, but equal parameters exist for all other measurements.

### Contents

The steps are divided into the following sections

- The section "Configuration" describes how to set up the basic parameters of the flowmeter. Step 1 in this section (read all parameter from SIFLOW) should always be carried out before changing any parameter in the module. This section can be carried out in PDM or in S7.
- The section "System optimization" describes how to optimize the system to gain better performance and precision. This section must be performed if an optimization of the system is needed. The section can be carried out in PDM or in S7.
- The section "Operation" describes how to prepare the system for operation. This section considers the parameters used in cyclic communication of the PLC program (i.e. process variable and service information).

Step	Description	Section
STEP 1	Reading all parameters from the SIFLOW into the DB_FLOW_PARA	CONFIGURATION
STEP 2	Setting basic parameters in SIFLOW	

9.2 Step-by-step guide to commissioning with S7

STEP 3	Zero point adjustment	SYSTEM OPTIMIZATION
STEP 4	System ready for operation	OPERATION

**S7 demo software**

The following software is used in the step-by-step guide:

- S7 library with S7 demo software written in ladder and STL.

The demo software shows in examples which parameters and commands are necessary to set and carry out to put the system into operation.

The demo program includes 4 steps. Each step has one or more S7 program folder(s) (see the following print screen). In order to execute the individual steps, copy the block index from S7 program of the appropriate step (e.g. "S7 Prog\_Step1->Blocks") to "S7 Prog\_Actual->Blocks".

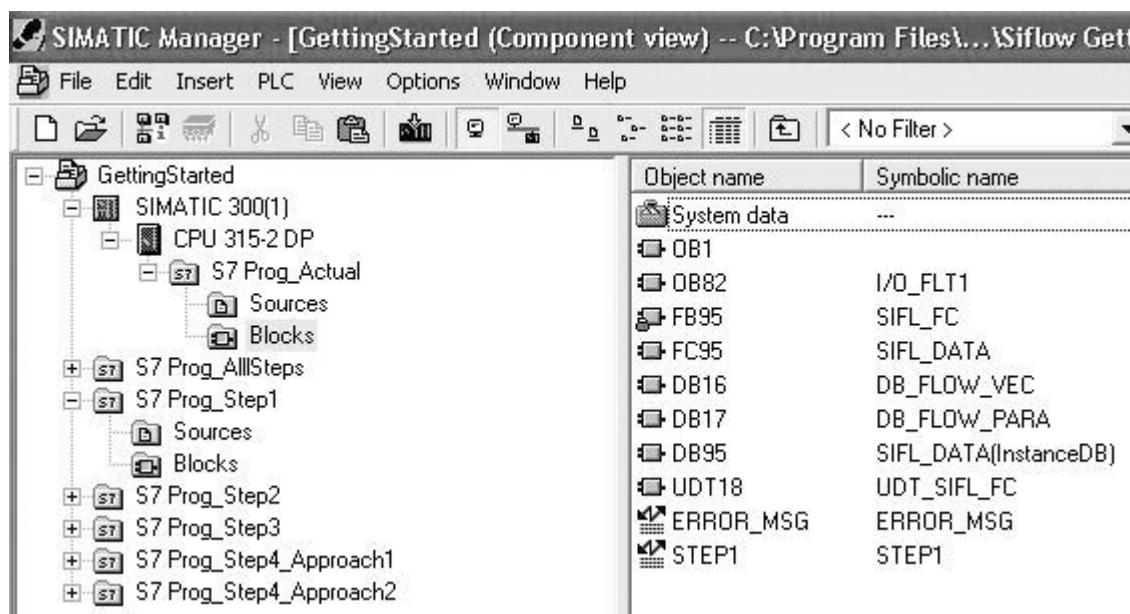

Figure 9-1 S7 program folders

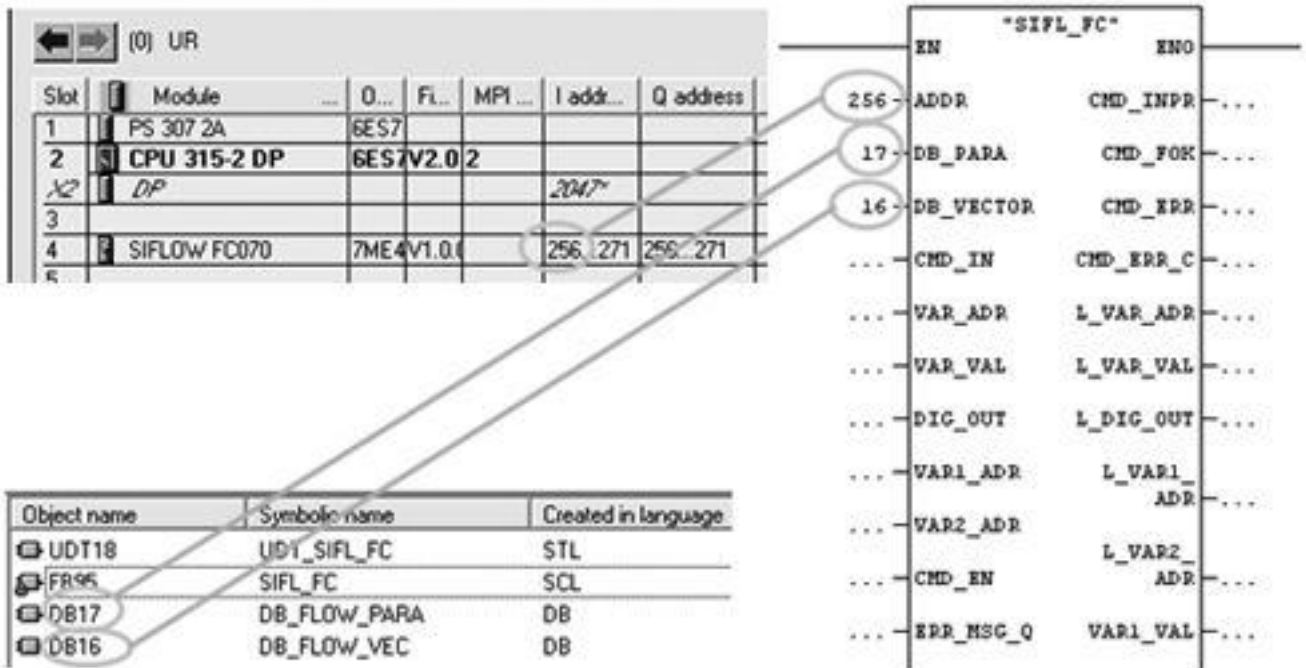

Figure 9-2 SIFL\_FC (FB 95) basic parameter setup

**Note**

The demo software can freely be changed, expanded (excl FB "SIFL\_FC", DB\_FLOW\_VECTOR and DB\_FLOW\_PARA) or copied.

Any claims resulting from the use of the demo-software are excluded.

**9.2.1 Step 1: Reading parameters into DB17 (DB\_FLOW\_PARA)**

Prior to any parameterization it is necessary to read all parameters from the SIFLOW module into DB\_FLOW\_PARA as DB\_FLOW\_PARA only contains default data and not sensor-specific data. Sensor-specific data are stored in the SENSORPROM situated in the back of the SIFLOW module.

**Read all parameters from SIFLOW**

1. Copy index of "S7 Prog\_Step1->Blocks" folder into "S7 Prog\_Actual->Blocks" folder and download to the PLC.
2. Prepare a program as shown below.

**Step 1: Read all parameters from SIFLOW (CMD\_IN = 649)**

When the bit "RD\_ALL" is set, SIFL\_FC initiates reading of all data from the SIFLOW FC070 module and stores them in the DB number addressed at DB\_PARA. In this case DB17, also named DB\_FLOW\_PARA.

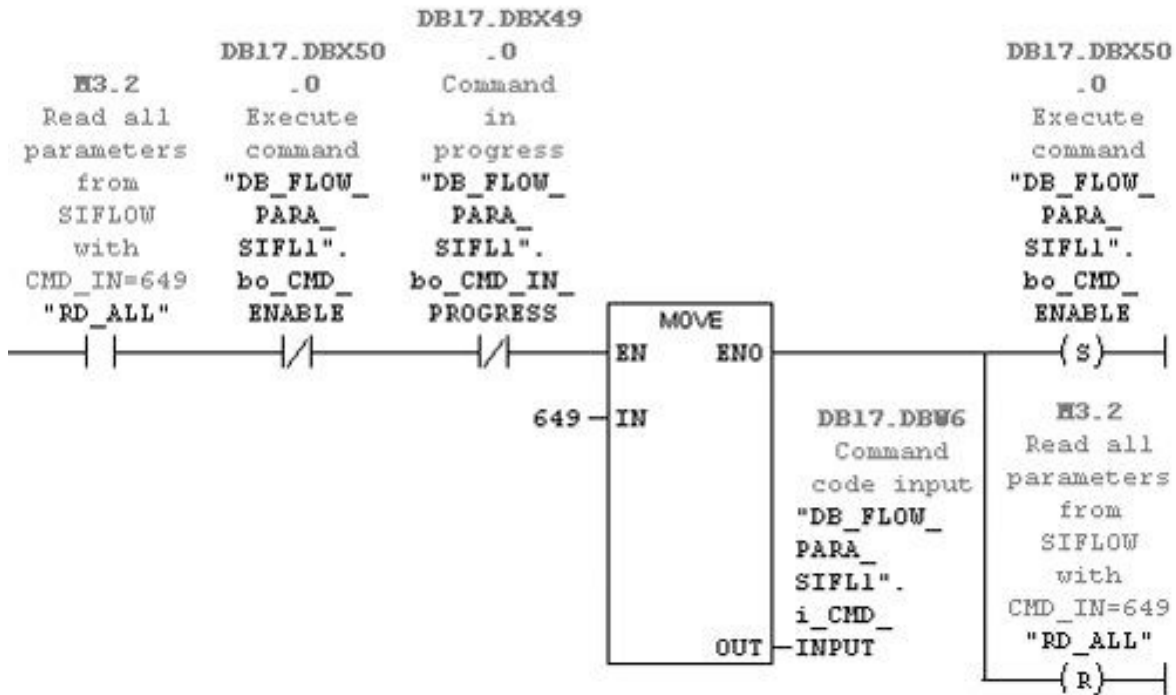

Figure 9-3 Step 1: Read all parameters from SIFLOW (CMD\_IN = 649)

1. Open the variable table "STEP1" and set bit "RD\_ALL" to true to read all parameters from SIFLOW to DB17 (DB\_FLOW\_PARA).  
Now all parameters are updated from the SIFLOW FC070 to DB\_FLOW\_PARA.
2. Make sure the sensor serial number parameter in the variable table matches the second part of the serial number written on the sensor label (e.g. 7ME410 125803N386)

Address	Symbol	Display form	Status value	Modify value
M 3.2	"RD_ALL"	BOOL	True	True
DB17.DBB 776	"DB_FLOW_PARA" s_SensorInfo s_Sens_ser_no[1]	CHARACTER	1'	
DB17.DBB 777	"DB_FLOW_PARA" s_SensorInfo s_Sens_ser_no[2]	CHARACTER	2'	
DB17.DBB 778	"DB_FLOW_PARA" s_SensorInfo s_Sens_ser_no[3]	CHARACTER	3'	
DB17.DBB 779	"DB_FLOW_PARA" s_SensorInfo s_Sens_ser_no[4]	CHARACTER	4'	
DB17.DBB 780	"DB_FLOW_PARA" s_SensorInfo s_Sens_ser_no[5]	CHARACTER	5'	
DB17.DBB 781	"DB_FLOW_PARA" s_SensorInfo s_Sens_ser_no[6]	CHARACTER	6'	
DB17.DBB 782	"DB_FLOW_PARA" s_SensorInfo s_Sens_ser_no[7]	CHARACTER	7'	
DB17.DBB 783	"DB_FLOW_PARA" s_SensorInfo s_Sens_ser_no[8]	CHARACTER	8'	
DB17.DBB 784	"DB_FLOW_PARA" s_SensorInfo s_Sens_ser_no[9]	CHARACTER	9'	
DB17.DBB 785	"DB_FLOW_PARA" s_SensorInfo s_Sens_ser_no[10]	CHARACTER	0'	

Figure 9-4 Step 1

## 9.2.2 Step 2: Setting basic parameters

In any application the basic parameters to be defined are:

- Measurement range of the application (min - max)
- Measurement unit.

### Note

#### Units and ranges in the Getting Started example

Measurement units are kg/h (values can be found in Appendix B (Page 195).

Upper value for MASSFLOW\_MAX is 250 kg/h. FC300 DN4 is default 150 kg/h.

Lower value for MASSFLOW\_MIN is 0 kg/h. FC300 DN4 is default 0 kg/h.

### Changing settings

1. Copy index of "S7 Prog\_Step2->Blocks" folder to "S7 Prog\_Actual->Blocks" folder (override the existing blocks) and download to the PLC.
2. Prepare a program as shown below.

#### Step 2: Write basic settings to SIFLOW (CMD\_IN = 699)

This network prepares the settings to be sent to SIFLOW.

Units and upper and lower values for MASSFLOW are changed.

Units are located in DR 2 and upper/lower values in DR 3.

9.2 Step-by-step guide to commissioning with S7

Thus, command i\_CMD\_INPUT=699, which writes all data records from DR 2 to DR 12, is used. Alternatively, data records can be written separately:

DR 2 => i\_CMD\_INPUT=402

DR 3 => i\_CMD\_INPUT=403

A programming sequence must be programmed to handle this, however.

The user must configure the parameters "MASSFLOW\_UNIT", "MASSFLOW\_MAX" and "MASSFLOW\_MIN".

When bit "WR\_BASIC" is set, SIFL\_FC initiates writing of all data from "DB\_FLOW\_PARA" to the SIFLOW FC070 module.



Figure 9-5 Step 2: Write basic settings to SIFLOW (CMD\_IN = 699)

1. Open the variable table "STEP2" and set the parameters "MASSFLOW\_UNIT", "MASSFLOW\_MAX" and "MASSFLOW\_MIN" and modify variables (i.e. update DB17 with these values).
2. Set bit "WR\_BASIC" to true to write all parameters from DB17 (DB\_FLOW\_PARA) to the SIFLOW module. DB\_FLOW\_PARA.s\_Units.b\_Massflow\_unit, DB\_FLOW\_PARA.s\_BasicSettings.r\_Massflow\_max and DB\_FLOW\_PARA.s\_BasicSettings.r\_Massflow\_min are now updated in the variable table.

Address	Symbol	Display format	Status value	Modify value
1	M 3.4 "WR_BASIC"	BOOL	false	true
4	MB 60 "MASSFLOW_UNIT"	DEC	0	
5	MD 61 "MASSFLOW_MAX"	FLOATING_POINT	250.0	250.0
6	MD 65 "MASSFLOW_MIN"	FLOATING_POINT	0.0	
8	DB17.DBB 80 "DB_FLOW_PARA_SIFL1".s_Units.b_Massflow_unit	DEC	0	
9	DB17.DBD 108 "DB_FLOW_PARA_SIFL1".s_BasicSettings.r_Massflow_max	FLOATING_POINT	250.0	
10	DB17.DBD 136 "DB_FLOW_PARA_SIFL1".s_BasicSettings.r_Massflow_min	FLOATING_POINT	0.0	

Figure 9-6 Step 2

**CAUTION**

In case of system failure (SF LED = red on the SIFLOW module), go to section "Diagnosing and troubleshooting" (Page 171).

Make sure that there is no failure or unacknowledged error before continuing with the next steps.



### 9.2.3 Step 3: System optimization

The flowmeter system is optimized through a zero point adjustment.

#### Performing a zero point adjustment

1. Install shut-off devices in the pipeline. If possible, both upstream and downstream of the sensor. Otherwise:
  - in horizontal installations at the outlet
  - in vertical installations at the inlet
2. Pump liquid at max. flow through the sensor (min. 2 min) in order to avoid air in the liquid.
3. Stop the flow while pumping by shutting off the outlet valve and then the inlet valve. Wait min. 1 min. In this way there will be zero flow but the liquid remains pressurized within the sensor, hindering de-gassing of the liquid, i.e. the release of air or other gas from the liquid.

#### Note

The flow must be completely stopped and the sensor completely filled with liquid.

4. Copy index of "S7 Prog\_Step3->Blocks" folder into "S7 Prog\_Actual->Blocks" folder and download to the PLC.
5. Prepare a program as shown below.

#### Step 3.1: Perform zero point adjustment (CMD\_IN = 18)

When "CMD\_ZERO\_POINT" is set, the zero point adjustment starts.

The zero point adjustment will run for 30 seconds if this setting has not been changed.

As long as the zero point adjustment is running, bit 9 in d\_SC\_STATUS on SIFL\_FC is TRUE (d\_SC\_STATUS counts bits 0 ... 31)

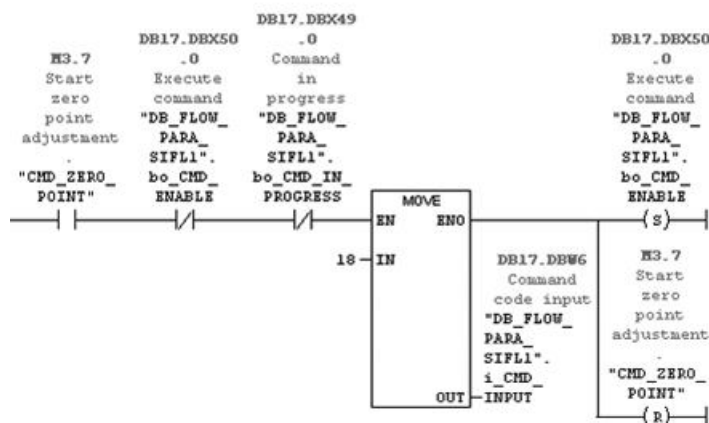

Figure 9-7 Step 3,1; Perform a zero point adjustment (CMD\_IN = 18)

9.2 Step-by-step guide to commissioning with S7

1. Open the variable table "STEP3" and set bit "CMD\_ZERO\_POINT" to true to start the zero point adjustment.
2. View "ZERO\_ADJUST\_IN\_PROGRESS" bit in the variable table and wait until it gets low. This bit goes high when starting the zero point adjustment and low again when zero point adjustment is completed.
3. Set bit "RD\_ALL" to true to read all parameters from SIFLOW module to DB17 (DB\_FLOW\_PARA).
4. Verify the zero sigma value (DB\_FLOW\_PARA.s\_ServiceInformation.r\_Zero\_sigma) and zero offset value (DB\_FLOW\_PARA.s\_ServiceInformation.r\_Zero\_offset\_value). These values should not exceed their limits (DB\_FLOW\_PARA.s\_BasicSettings.r\_Zero\_sigma\_limit and DB\_FLOW\_PARA.s\_BasicSettings.r\_Zero\_offset\_limit).

Address	Symbol	Display format	Status value	Modify value
M 3.7	"CMD_ZERO_POINT"	BOOL	false	true
DB17.DBD 42	"DB_FLOW_PARA_SF11.s_SC_STATUS"	BIN	20000_0100_0000_0000_0010_0000_0000	
DB17.DBD 44.1	"ZERO_ADJUST_IN_PROGRESS"	BOOL	200	
M 3.2	"RD_ALL"	BOOL	false	
DB17.DBD 168	"DB_FLOW_PARA_SF11.s_BasicSettings.r_Zero_sigma_limit"	FLOATING_POINT	100.0	
DB17.DBD 172	"DB_FLOW_PARA_SF11.s_BasicSettings.r_Zero_offset_limit"	FLOATING_POINT	100.0	
DB17.DBD 568	"DB_FLOW_PARA_SF11.s_ServiceInformation.r_Zero_sigma"	FLOATING_POINT	0.0	
DB17.DBD 560	"DB_FLOW_PARA_SF11.s_ServiceInformation.r_Zero_offset_value"	FLOATING_POINT	-70.0	

Figure 9-8 Step 3

**CAUTION**

In case of system failures (SF led = red on the SIFLOW module), refer to section "Diagnosing and troubleshooting" (Page 171).

Make sure that there is no failure or unacknowledged error before continuing with the next steps.

See also

A detailed description of problems with zero point adjustment can be found in chapter "Diagnosing and troubleshooting" (Page 171).

9.2.4 Step 4: System ready for operation

The system is now ready for normal operation. Process values can be fetched by:

1. Cyclic reading of process values from VAR\_1\_VAL or VAR\_2\_VAL (free of choice).
2. Reading all process values by means of CMD\_IN, reading DR30 which comprises all available process values.

### Approach 1 – cyclic reading of process values

VAR\_1\_VAL and VAR\_2\_VAL will show MASSFLOW and VOLUMEFLOW in default configuration. For every call of FB95 (SIFL\_FC) these values will be updated, thus performing a cyclic reading of the two most important values for a particular application.

In order to change the process values shown on VAR1\_VAL and VAR2\_VAL, new process value addresses must be used on the parameters VAR1\_ADR and VAR2\_ADR.

Parameter	Comment	Address
System status	32 bit system status. The same as SC_STATUS on SIFL_FC	4000
Mass flow	Unit according to DR2	3000
Volume flow	Unit according to DR2	3002
Density	Unit according to DR2	3004
Sensor temperature	Unit according to DR2	3006
Fraction A flow	Unit according to DR2	3008
Fraction B flow	Unit according to DR2	3010
Percent fraction A	Unit according to DR2	3012
Totalizer 1	Unit according to DR2	3022
Totalizer 2 batch	Unit according to DR2	3024

1. Copy index of "S7 Prog\_Step4\_Approach1->Blocks" folder into "S7 Prog\_Actual->Blocks" folder and download to the PLC.
2. Prepare a program as shown below.

#### Step 4 - approach 1: New address for VAR1\_VAL and VAR2\_VAL (CMD\_IN = 703 and 704)

This network sets a new process value (two values) to be updated in every cycle. "NEW\_VAR1\_ADDR" and "NEW\_VAR2\_ADDR" are the new addresses of the process values set by the user. When "SET\_VAR\_ADR" bit is set, it requires two write commands to change both values as they have different i\_CMD\_INPUT values.

Example: If the process values are changed to show density and sensor temperature, the user must set "NEW\_VAR1\_ADDR" = 3004 and "NEW\_VAR2\_ADDR" = 3006.

9.2 Step-by-step guide to commissioning with S7

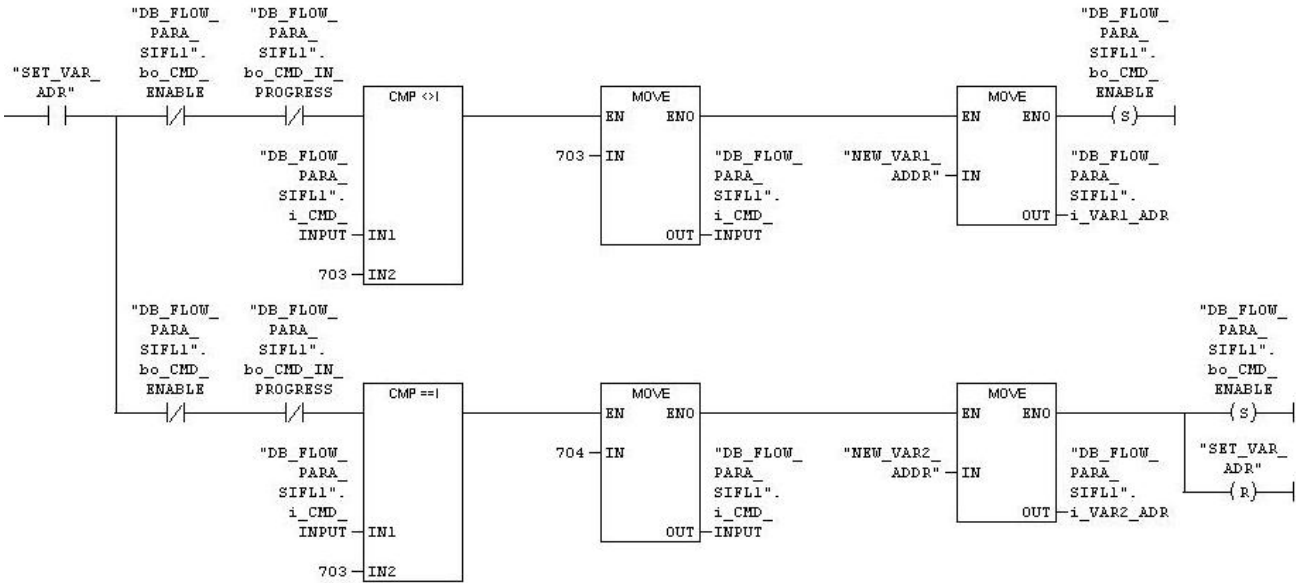

Figure 9-9 Step 4: Approach 1 – cyclic reading of process values

1. Open the variable table "STEP4\_appr1" and select process values from the table and write the appropriate values to NEW\_VAR1\_ADDR and NEW\_VAR2\_ADDR in the variable table (e.g. to set VAR1\_VAL to density and VAR2\_VAL to temperature, set NEW\_VAR1\_ADDR = 3004 and NEW\_VAR2\_ADDR = 3006).
2. Set bit "SET\_VAR\_ADR" to active to change VAR1\_VAL and VAR2\_VAL.

	Address	Symbol	Display format	Status value	Modify value
1	M 3.6	"SET_VAR_ADR"	BOOL	false	true
2					
3	MM 26	"NEW_VAR1_ADDR"	DEC	3004	3004
4	MM 28	"NEW_VAR2_ADDR"	DEC	3006	3006
5	DB17.DBW 16	"DB_FLOW_PARA".i_VAR1_ADR	DEC	3004	
6	DB17.DBW 18	"DB_FLOW_PARA".i_VAR2_ADR	DEC	3006	
7					
8	DB17.DBW 38	"DB_FLOW_PARA".i_LAST_VAR1_ADR	DEC	3004	
9	DB17.DBW 40	"DB_FLOW_PARA".i_LAST_VAR2_ADR	DEC	3006	
10	DB17.DBD 22	"DB_FLOW_PARA".d_VAR1_VALUE	FLOATING_POINT	15.13854	
11	DB17.DBD 26	"DB_FLOW_PARA".d_VAR2_VALUE	FLOATING_POINT	23.81979	
12	DB17.DBX 49.3	"DB_FLOW_PARA".bo_VAR1_OK	BOOL	true	
13	DB17.DBX 49.4	"DB_FLOW_PARA".bo_VAR2_OK	BOOL	true	
14					
15					

Figure 9-10 Step 4 - Approach 1

### Approach 2 – Reading of all process values with DR30

If more than two process values are needed, all process values can be read by means of CMD\_IN, reading DR30 which comprises all available process values.

1. Copy index of "S7 Prog\_Step4\_Approach2->Blocks" folder into "S7 Prog\_Actual->Blocks" folder and download to the PLC.
2. Prepare a program as shown below.

#### Step 4 - approach 2: Read all process values in DR 30 (CMD\_IN = 230)

Prepare reading of all process values from SIFLOW.

This network issues the i\_CMD\_INPUT = 230 which reads all process values from SIFLOW and stores them in DB17 "DB\_FLOW\_PARA".

9.2 Step-by-step guide to commissioning with S7

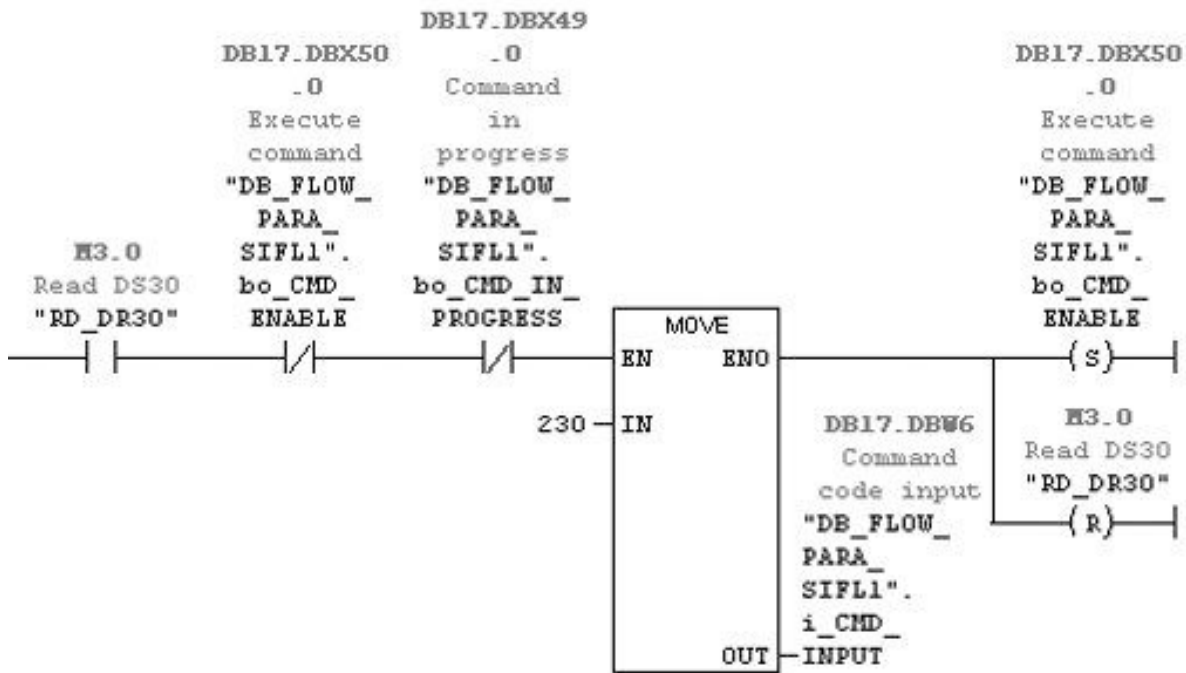

Figure 9-11 Approach 1 – cyclic reading of process values 2

1. Open the variable table "STEP4\_appr2" and set bit "RD\_DR30" to active to read data record 30 from the SIFLOW module to DB17 (DB\_FLOW\_PARA).

Address	Symbol	Display format	Status value	Modify value
M 3.0	"RD_DR30"	BOOL	false	true
DB17.DBD 484	"DB_FLOW_PARA".s_ProcessValues.r_Massflow	FLOATING_POINT	0.0009509333	
DB17.DBD 488	"DB_FLOW_PARA".s_ProcessValues.r_Volumeflow	FLOATING_POINT	1.745053e-008	
DB17.DBD 492	"DB_FLOW_PARA".s_ProcessValues.r_Density	FLOATING_POINT	15.13697	
DB17.DBD 496	"DB_FLOW_PARA".s_ProcessValues.r_Sensor_temperature	FLOATING_POINT	23.85925	
DB17.DBD 512	"DB_FLOW_PARA".s_ProcessValues.r_Totalizer_1	FLOATING_POINT	518003.8	
DB17.DBD 516	"DB_FLOW_PARA".s_ProcessValues.r_Totalizer_2_batch	FLOATING_POINT	517955.0	

Figure 9-12 Step 4 - Approach 2

## Custody transfer

This chapter describes how to set up a custody transfer (CT) application with SIFLOW FC070 Ex CT.

There are two possible ways of performing a custody transfer application. Using Digital output with phase shift or using the SIFLOW CT OCX ActiveX component in a Simatic HMI panel.

---

### Note

Only SIFLOW FC070 Ex CT version supports custody transfer

Before reading this chapter, you have to read the following chapters:

- Hardware installation and removal
  - Connecting
  - Software installation
  - Programming in SIMATIC S7
- 

## 10.1 Identify actual SIFLOW version

Before any parameterization is made, it is necessary to read all parameters from the SIFLOW to identify the actual version of the device.

## 10.2 Step-by-step guide for configuration of SIFLOW CT functions

### Configuring CT using Digital output with Simatic PDM

Step 1: Change the write protection switch to "OFF".

Step 2: Read parameters from SIFLOW FC070.

Step 3: Select the digital output – "Redundancy pulse/frequency 90°" or "Redundancy pulse/frequency 180°" .

Parameter	Value	Unit	Status
» » » Digital Output			
Digital Output	Redundancy Pulse 180°		
Measurement Function	Mass Flow		
Unit	kg		
Mass/Pulse	0,039999999	kg	
Pulse Output Direction	Unidirectional		
Pulse Width	8.2 ms		
Pulse Polarity	Normally closed if no Pulse		
SF Reaction	No Reaction		

Step 4: Change OCX values to "No Process Value Select".

10.4 Enable write access

---

*** OCX	
SW Version Type	V
Process Value 1 ID	No Process Value Select
Process Value 2 ID	No Process Value Select
OCX Main Number	1
OCX Sub Number	0

Step 5: Download settings to device.

Step 6: Change the write protection switch to "ON".

---

**Note**

See also DR5 Digital output and DR39 CT parameters when configuring is made from S7.

---

## 10.3 Configuring the CT version

### Using Siflow CT OCX for Simatic HMI

Using the Siflow OCX component means encrypted backplane communication between the SIFLOW FC070 and the HMI panel (OCX).

## 10.4 Enable write access

To be able to write to the SIFLOW FC070 Ex CT module the write protection switch (Page 33) has to set to "OFF".



## 10.5 Hardware and software requirements

### Hardware and software requirements

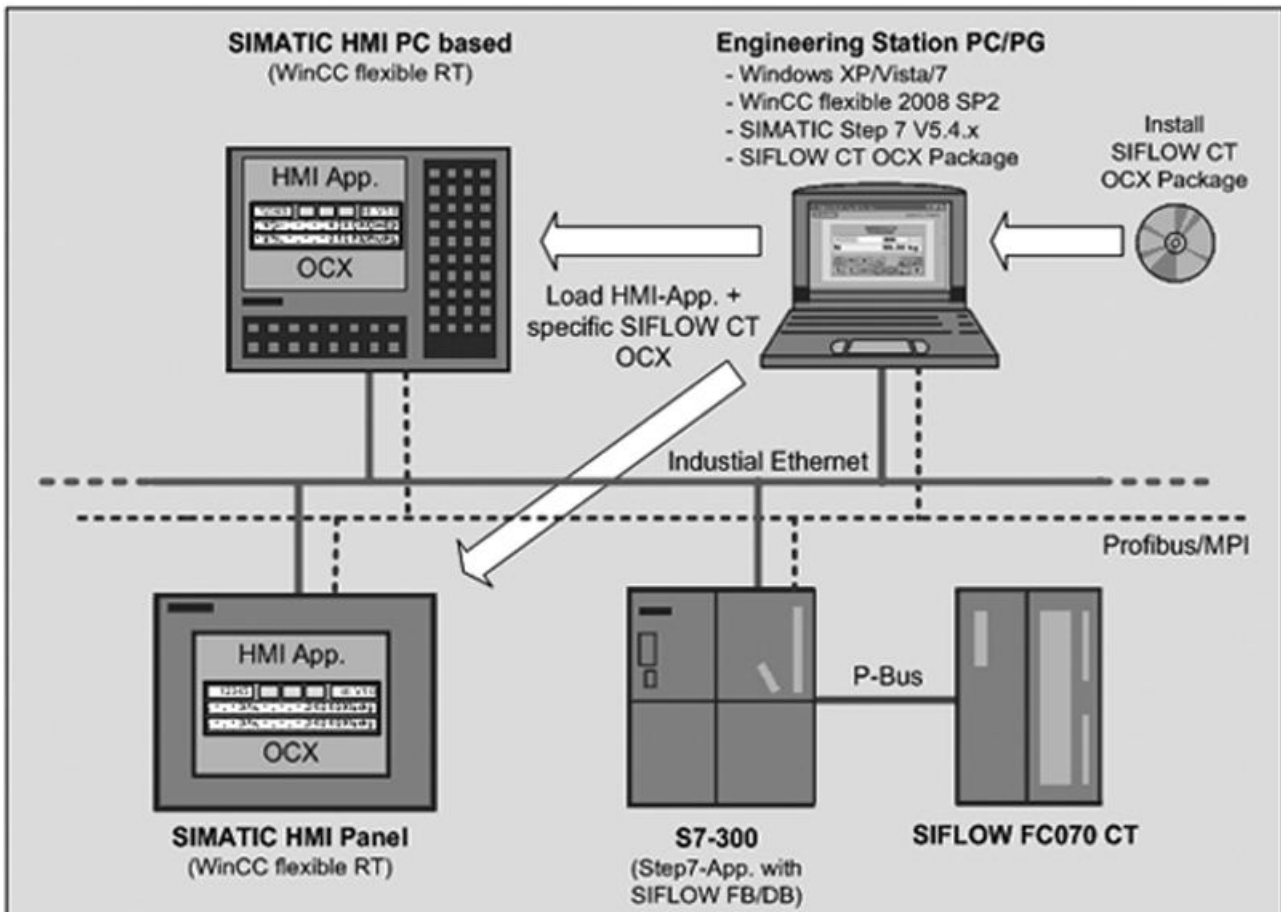

Figure 10-1 Hardware and software requirements

The figure above shows the hardware and software requirements for building SIMATIC HMI applications using the SIFLOW CT OCX for displaying calibrated values from the SIFLOW FC070 CT module.

The basic hardware and software requirements are defined by WinCC flexible 2008 SP2 and SIMATIC S7 V5.4.x. Please refer to the descriptions of the hardware and software requirements of WinCC flexible 2008 SP2 and SIMATIC S7 V5.4.x.

The SIFLOW CT OCX can be used with WinCC flexible 2008 SP2 and newer versions. Older versions of WinCC flexible are not supported.

## 10.6 Installing the SIFLOW CT OCX

Before installing the SIFLOW CT OCX package, ensure that WinCC flexible 2008 SP2 is installed on the engineering station. The installation will fail if WinCC flexible 2008 SP2 is not installed on the engineering station.

Before starting the Setup program, close all applications (such as Microsoft Word, etc.), as Windows must be restarted after the installation of SIFLOW CT OCX so that the OCX can be completely integrated into the WinCC environment.

The SIFLOW CT OCX package setup consists of two files:

setup.exe	The setup frame application
SCOVxxx.msi	The windows installer file of the setup (e.g. SCOV01.00.00.00_01.02.msi)

Start the setup program by double-clicking the setup.exe program and follow the installation steps.

If the setup program detects the installation of an old version of the SIFLOW CT OCX, the old version will be uninstalled before installation of the new version.

You cannot install an old SIFLOW CT OCX version over a newer version. If you want to do so, you must manually uninstall the new version prior to installation of the old version.

After finishing the installation of the SIFLOW CT OCX, the target system must be restarted otherwise the OCX will not be visible in WinCC flexible.

---

### Note

SIFLOW CT OCX registers itself in the system files of the MS Windows operating system. You cannot delete, move or rename SIFLOW CT OCX files or folders using Microsoft Windows utilities such as the Explorer or modify SIFLOW CT OCX data in the Microsoft Windows registry. The control may no longer run properly after such modifications.

---

## 10.7 Removing the SIFLOW CT OCX

Use the Microsoft Windows application "Add/Remove Programs" (for example, under MS Windows XP in the taskbar in ...> Settings > Control Panel > Add/Remove Programs) to remove your software package (for example, "SIFLOW CT OCX V1.0 for WinCC flexible 2008 SP2").

As an alternative, you can use the SIFLOW CT OCX setup program to uninstall a program.

## 10.8 Compatibility requirements

The following compatibility requirements must be fulfilled for correct function of the provided SIFLOW CT OCX version:

SIFLOW CT OCX version V1.0 requires

SIFLOW FC070 CT FW version:	V2.0.0 or newer
SIMATIC FB95 or 695:	V2.0

## 10.9 Supported devices

The SIFLOW CT OCX will be provided for several devices/platforms like OP/TP/MP Panels, the WinCC flexible PC-Runtime and for integration in the WinCC flexible 2008 Engineering System (ES). For each device a specific OCX must be provided, to support the different device platforms.

In version V1.0 or newer only PC-based panels and panels with Windows CE 5.0 platforms will be supported by the OCX.

The table below lists the devices and platforms supported by the current OCX version in detail.

Table 10-1 Devices supported by the SIFLOW ActiveX control

Device	OC platform	WinCC flexible Version 2008 SP2	Supported by Opp V4.4	Supported by SIFLOW CT OCX
<b>PC/WinCC flexible ES</b>	Windows XP/Vista / 7	yes	yes	V1.0 or newer
TP170B color	Windows CE 3.0	yes	no	no
TP170B mono	Windows CE 3.0	yes	no	no
TP170A	-	no	no	no
OP170B mono	Windows CE 3.0	yes	no	no
TP177A 6"	-	no	no	no
TP177A 6" (Portrait)	-	no	no	no
TP177B mono DP	Windows CE 3.0	yes	yes	no
TP177B color PN/DP	Windows CE 3.0	yes	yes	no
TP177B 4" color PN/DP	Windows CE 5.0	yes	yes	V1.0 or newer
OP177B mono DP	Windows CE 3.0	yes	yes	no
OP177B color PN/DP	Windows CE 3.0	yes	yes	no
TP270 6"	Windows CE 3.0	yes	no	no
TP270 10"	Windows CE 3.0	yes	no	no
TP277 6"	Windows CE 3.0	yes	yes	no
OP270 6"	Windows CE 3.0	yes	no	no
OP270 10"	Windows CE 3.0	yes	no	no
OP277 6"	Windows CE 3.0	yes	yes	no
MP370 12" Key	Windows CE 3.0	yes	no	no
MP370 12" Touch	Windows CE 3.0	yes	no	no
MP370 15" Touch	Windows CE 3.0	yes	no	no
MP270 6" Touch	Windows CE 3.0	yes	no	no
MP270 10" Touch	Windows CE 3.0	yes	no	no
MP270 10" Key	Windows CE 3.0	yes	no	no
MP277 8" Touch	Windows CE 5.0	yes	yes	V1.0 or newer
MP277 10" Key	Windows CE 5.0	yes	yes	V1.0 or newer

10.10 Layout of the SIFLOW CT OCX

Device	OC platform	WinCC flexible Version 2008 SP2	Supported by Opp V4.4	Supported by SIFLOW CT OCX
MP277 10" Touch	Windows CE 5.0	yes	yes	V1.0 or newer
MP377 12" Key	Windows CE 5.0	yes	yes	V1.0 or newer
MP377 12" Touch	Windows CE 5.0	yes	yes	V1.0 or newer
MP377 15" Touch	Windows CE 5.0	yes	yes	V1.0 or newer
MP377 19" Touch	Windows CE 5.0	yes	yes	V1.0 or newer

10.10 Layout of the SIFLOW CT OCX

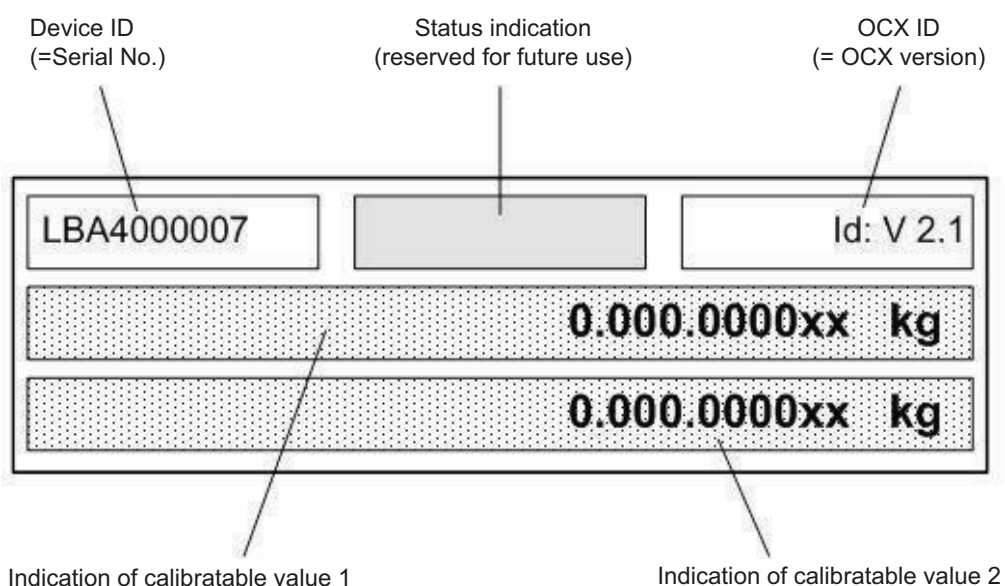

Figure 10-2 Layout of the SIFLOW CT Secure OCX

The figure above shows the currently provided layout of the OCX.

The OCX displays the following items:

Table 10-2 Items of the SIFLOW CT OCX layout

Item	Description
Device ID	The device ID displayed in this section is the serial number of the SIFLOW FC070 Ex CT module as provided through data record 37
Status indication	Currently unused. Reserved for future use

Item	Description
OCX ID	Version of the SIFLOW CT OCX providing the current display. This version must be set in parameter section of the SIFLOW FC070 Ex CT module, otherwise the data exchange will not work and no values will be displayed
Indication of calibratable values 1 and 2	In this section the calibratable value and unit will be displayed according to its parameterization (e.g. with PDM). If value is not parameterized, "----" will be displayed in this section. The value will be displayed as a float value currently limited to two fractional digits (e.g. 1234.56 kg). The value will be rounded to nearest. If errors occur, the text "ERROR <Error code> will be displayed in the value section (e.g. "ERROR 3"). For a list of errors, please refer to error codes below.

In addition the color of the text and the background of the control can be adjusted within the WinCC flexible Engineering System.

## 10.11 Error codes

In case of error the Text "ERROR <Error code>" will be displayed in the value section of the SIFLOW CT OCX.

The following table provides a description of the error codes:

Table 10-3 Error codes displayed in the SIFLOW CT OCX

Error code	Description
1	Data timeout. No valid data received within timeout (currently 3 seconds) from the SIFLOW FC070 Ex CT module
2	Authentication timeout. AUTH indication in DR37.status did not change
3	Error COM_ERR in DR37.status signaled by the SIFLOW FC070 Ex CT module
4	Error ST_SF in DR37.status signaled by the SIFLOW FC070 Ex CT module
5	The CRC of the received data is not valid. Decryption of dataset failed or data are corrupted
6	Invalid unit ID received
7	Error during conversion of float value to string
8	The value that should be displayed does not fit to display area

## 10.12 Supported languages

The SIFLOW CT OCX, including the property views of the OCX in WinCC flexible ES, and the setup of the package only supports English.

## 10.13 Limitations

The current version of the SIFLOW CT OCX has the following limitation:

- Panels based on the Windows CE 3.0 platform are currently not supported.

## 10.14 Configuring and operating the SIFLOW CT OCX

The SIFLOW CT OCX package must be installed on the engineering station for use within WinCC flexible ES. On the engineering station the device-specific HMI application, including the SIFLOW CT OCX for displaying calibratable values, must be built for S7-300 automation systems with integrated SIFLOW FC070 Ex CT module. After that the HMI application including the device-specific SIFLOW CT OCX must be downloaded to the panel through the WinCC flexible ES. The calibratable values from the SIFLOW FC070 Ex CT module can then be displayed on the panel. The supported panels are listed in "Supported devices" (Page 99). The calibratable values are provided to the OCX within the HMI application through exchanging data with the S7 application running the SIFLOW FB/DBs in order to handle the communication with the SIFLOW FC070 Ex CT module, see "Description" (Page 21).

### 10.14.1 Creating the HMI project

After the SIFLOW CT OCX has been installed on the engineering station, a WinCC flexible project must be established for the desired HMI panel. This can be accomplished by using the project wizard within WinCC flexible. To simplify the setup of connections and tags, it is recommended to integrate the WinCC flexible project with the associated S7 project. Please refer to documentation of S7 and WinCC flexible for further descriptions.

The following figure shows a WinCC flexible project for a MP277 8" Touch panel and the appearance of the SIFLOW CT OCX within an HMI screen.

10.14 Configuring and operating the SIFLOW CT OCX

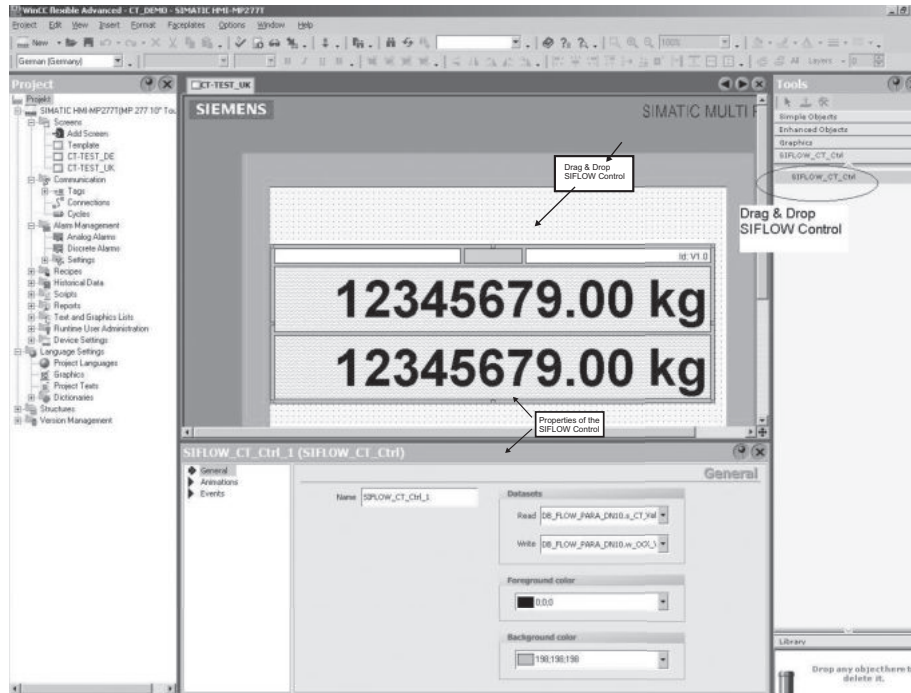

Figure 10-3 SIFLOW CT OCX within a WinCC flexible project

The SIFLOW CT OCX will be displayed in the Tools pane of WinCC flexible labelled as "SIFLOW\_CT\_Ctrl". The control can be integrated in an HMI screen by simply dragging and dropping onto the desired screen. The size of the control can be adjusted by dragging the small blue boxes enclosing the control.

If the SIFLOW CT OCX control is selected, the properties pane appears showing the properties of the SIFLOW CT OCX that can be set.

The following properties can be set:

Table 10-4 Properties of the SIFLOW CT OCX

Property	Description
Name	Name of the control for identification within the WinCC flexible HMI project
Data records - Read	The tag that represents the data of data record 37 on the associated SIMATIC PLC. The WinCC flexible Runtime on the target panel provides data represented through this tag to the SIFLOW CT OCX during operation time Before the tag can be associated, it must be setup in the "Communication" section of WinCC flexible. See "Setting up tag representing input data for OCX read" (Page 105) for a detailed description.

Property	Description
Data records -Write	The tag that represents the I/O data of SIFLOW FC070 Ex CT on the associated SIMATIC PLC. The WinCC flexible Runtime on the target panel collects the output data from SIFLOW CT OCX and writes them to the output section (Byte 10-11) of the associated SIMATIC PLC that is represented through this tag. Before the tag can be associated, it must be setup in the "Communication" section of WinCC flexible. "Setting up tag representing output data for OCX write" (Page 106) for a detailed description.
Foreground color	The text color of the SIFLOW CT OCX
Background color	The background color of the SIFLOW CT OCX

### 10.14.2 Setting up the PLC connection

Before tags representing data on an associated PLC can be adjusted, and before downloading of the HMI project to a specific panel is possible, the connection between the panel and the PLC must be configured in WinCC flexible.

Insert a new connection and enter the appropriate data of the desired connection as shown in the figure below.



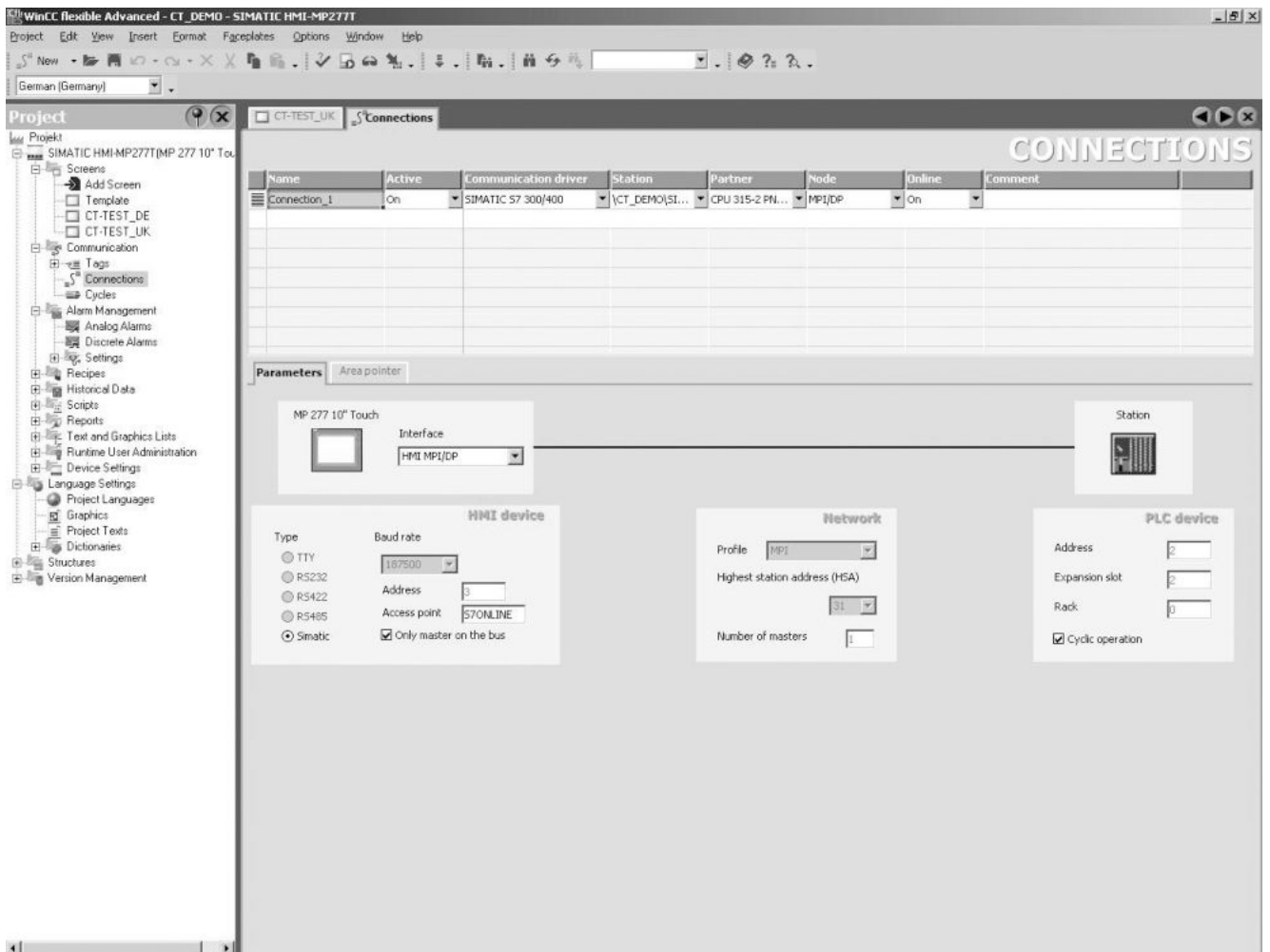

Figure 10-4 Setting up the connection between panel and PLC

### 10.14.3 Setting up tag representing input data for OCX read

The data displayed by SIFLOW CT OCX will be provided through the section "s\_CT\_Values" of the data record "DB\_FLOW\_PARA" on the SIMATIC PLC. The section "s\_CT\_Values" represents data according DR37. For a brief description of the appropriate data record, appendix "Data records" (Page 201).

In the "Tags" section within the "Communication" item of WinCC flexible tags used within the HMI project can be defined. If the WinCC flexible project is integrated with an associated S7 project, the tag can be set up by simply selecting the appropriate PLC variable from the drop-down box while inserting a new tag.

The figure below shows the necessary settings for the tag representing data record 37. It is important to set the "Data type" of the tag to "Byte" and the "Array elements" to "32" as shown in the figure below. Otherwise the data exchange will not work.

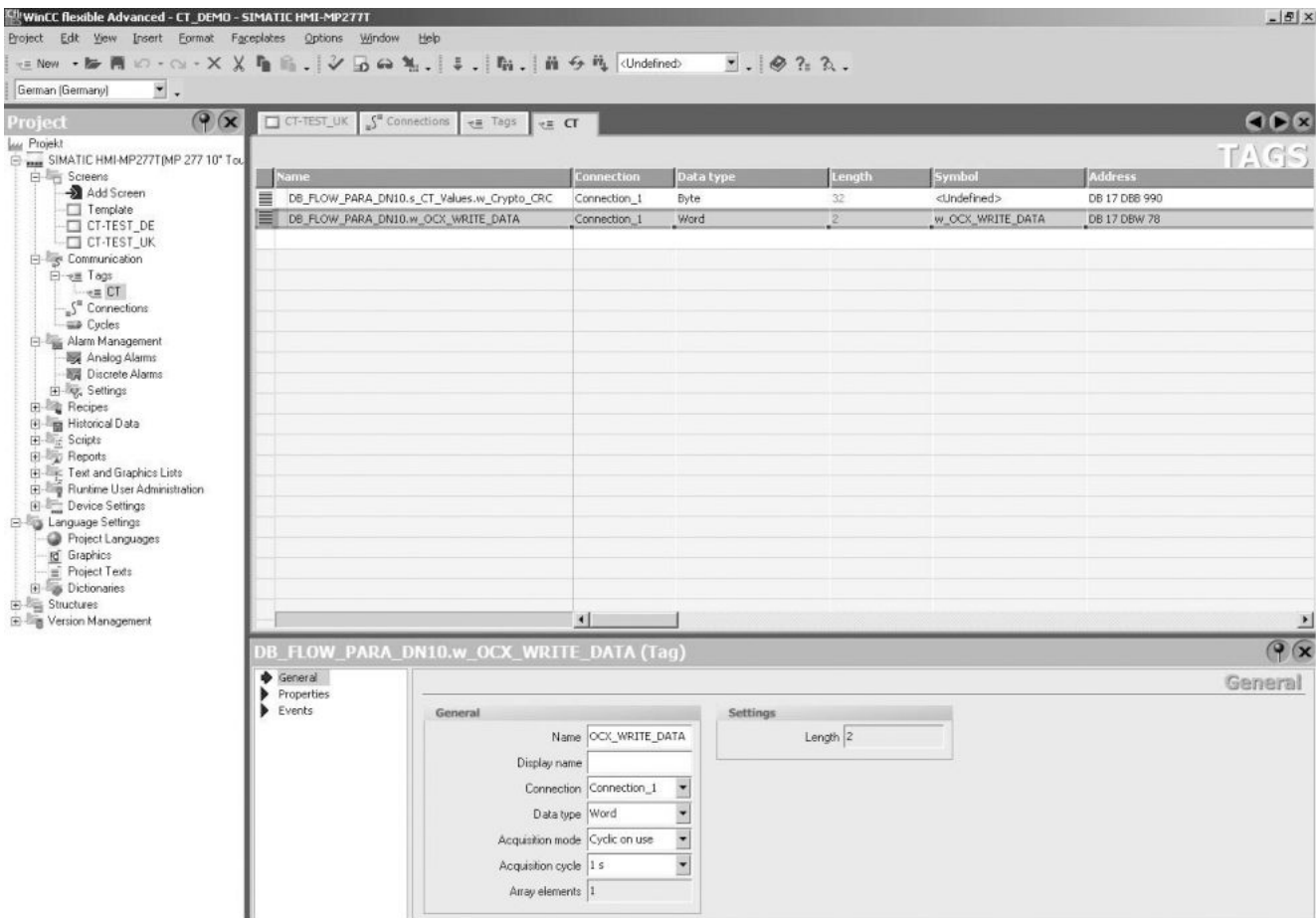

Figure 10-5 Setting up tag representing data record 37

The "Acquisition cycle" should be in the range below 3 seconds, because the communication timeout controlled by the OCX and the FW on the SIFLOW module is set to a maximum of 3 seconds and will report an error, see "ERROR 1" (Page 101) if it is exceeded.

#### 10.14.4 Setting up tag representing output data for OCX write

The SIFLOW CT OCX communicates to the SIFLOW FC070 CT module by writing to output data section w\_OCX\_WRITE\_DATA of the DB\_FLOW\_PARA data record on the PLC. The SIFLOW FB running on the PLC transfers this output data to the SIFLOW FC070 Ex CT module by writing the data to Bytes 10 and 11 (OCX write data) of the s7\_control\_signals in the peripheral interface.

In the "Tags" section within the "Communication" item of WinCC flexible tags used within the HMI project can be defined. If the WinCC flexible project is integrated with an associated S7 project, the tag can be setup by simply selecting the appropriate PLC variable "DB\_FLOW\_PARA.w\_OCX\_WRITE\_DATA" from the drop-down box while inserting a new tag.

The figure below shows the necessary settings for the tag representing output data for OCX write. It is important to set the "Data type" of the tag to "Word" and the "Array elements" to "1" as shown in the figure below. Otherwise the data exchange will not work.

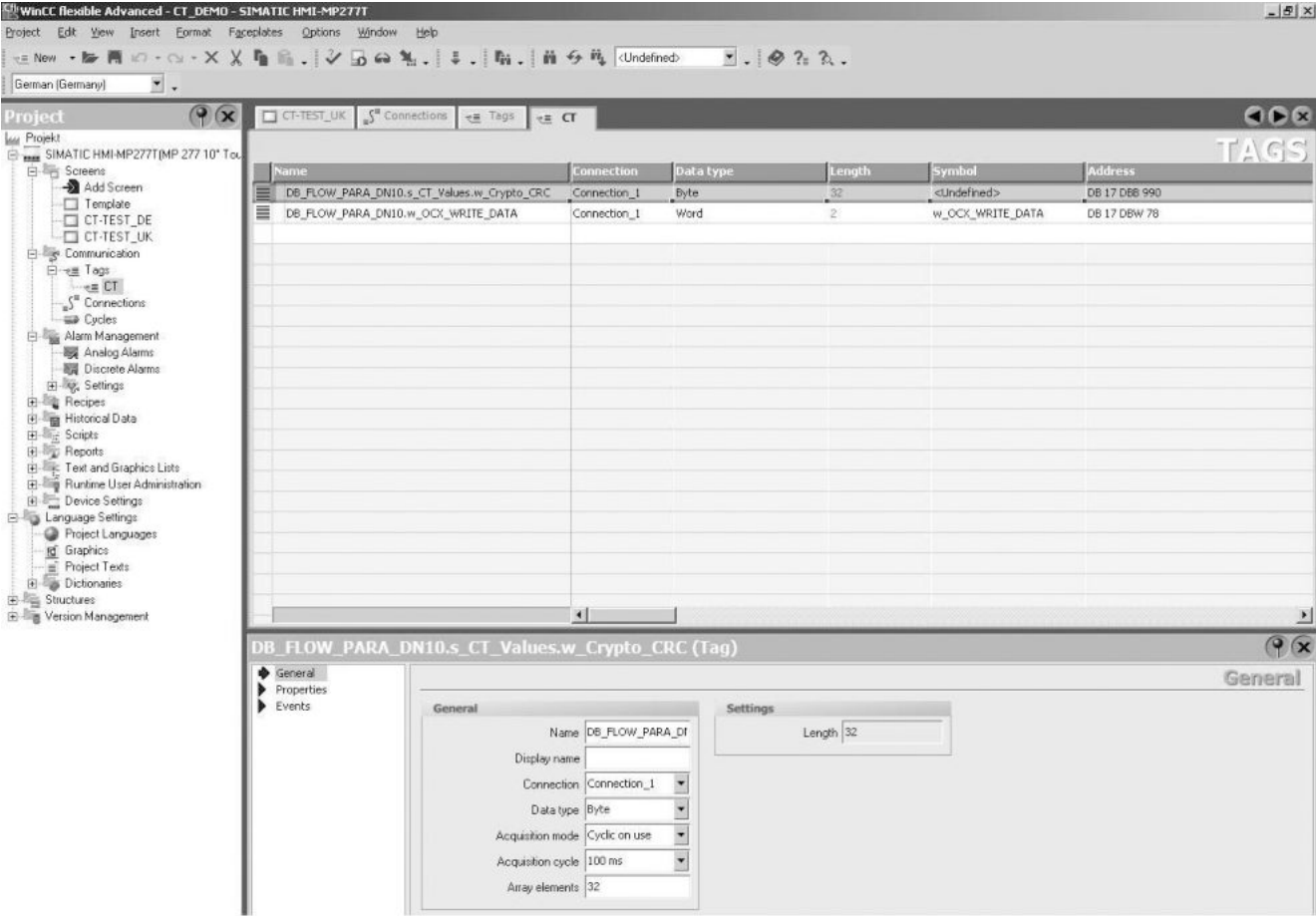

Figure 10-6 Setting up tag representing output data, bytes 10 and 11

The "Acquisition cycle" should be in the range below 3 seconds, because the communication timeout controlled by the OCX and the FW on the SIFLOW module is set to a maximum of 3 seconds and will report an error, see "ERROR 1" (Page 101) if it is exceeded.

### 10.14.5 Building the HMI project and transferring it to the panel

After setting up the HMI project it must be generated. From the WinCC flexible menu select Project>Compiler>Generate to build the project.

After successful generation you can download the HMI project to the desired panel by selecting Project>Transfer>Transfer...

For detailed descriptions of generation and transfer of HMI projects, see to the WinCC flexible documentation.

### 10.14.6 Parameterizing SIFLOW FC070 Ex CT with Simatic PDM

In order to be able to exchange data with the SIFLOW FC070 Ex CT module the correct CT parameters defined by DR 39 must be set correctly. In particular the version data (version type (case sensitive), OCX main and sub numbers) must be set according to the version of the used OCX. The current version of the OCX will be shown in WinCC flexible ES in the HMI project.

---

#### Note

##### Process Value 1/2 ID

If the value is "CT mode disabled", the OCX functions are disabled. The SIFLOW will **not** go into CT mode, even if redundant Digital output is used.

If the value is "No Process Value select" the OCX is disabled and the SIFLOW will go into CT mode if Redundant Digital output is used.

---

Parameter	Value	Unit	Status
» » » OCX			
SW Version Type	V		
Process Value 1 ID	Mass Flow		
Process Value 2 ID	Volume Flow		
OCX Main Number	1		
OCX Sub Number	0		

Figure 10-7 Parameterisation of the SIFLOW FC070 Ex CT

Changing from S7: See DR39 CT parameters.

---

#### Note

SW version must be "V" (upper case)

---

### 10.14.7 Reading data between SIFLOW CT OCX and SIFLOW Ex module

To be able to read Process value 1 and Process value 2, prepare a PLC program as shown below.

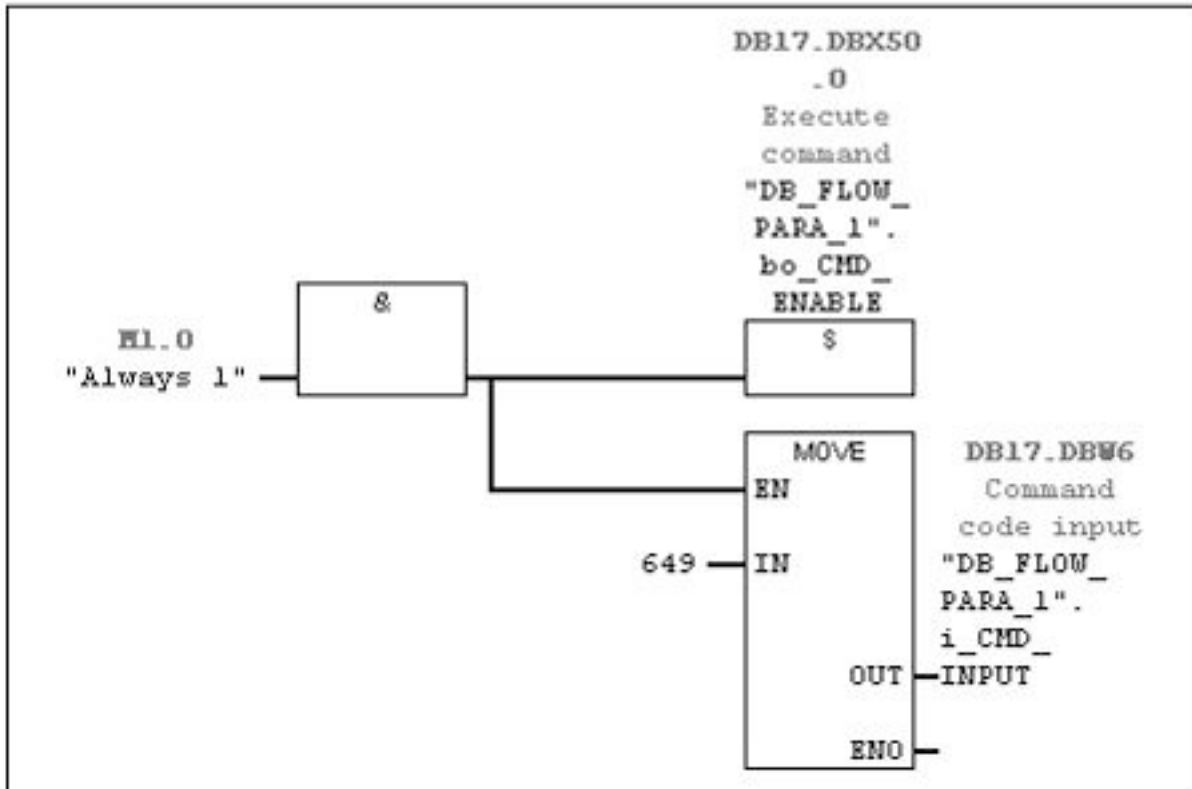

Figure 10-8 OCX example

### 10.15 Disable write access

To enable communication between SIFLOW FC070 CT OCX and the SIFLOW FC070 Ex CT module the write protection switch (Page 33) has to set to "ON".

## 10.16 Changing parameters in write protection mode with SIMATIC PDM

The following parameters can be changed in write protection mode:

» » Limit Monitoring			
» » » Limit 1			
Selection	Mass Flow		
Direction	Low Limit		
Setpoint	10,000	%	
Hysteresis	5,0	%	
» » » Limit 2			
Selection	Mass Flow		
Direction	Low Limit		
Setpoint	10,000	%	
Hysteresis	5,0	%	
» » » Limit 3			
Selection	Off		
Direction	Low Limit		
Setpoint	10,000	%	
Hysteresis	5,0	%	
» » » Limit 4			
Selection	Off		
Direction	Low Limit		
Setpoint	10,000	%	
Hysteresis	5,0	%	

Figure 10-9 Limit monitoring

Changing from S7 - DB\_FLOW\_PARA: See DR12 Limit default settings

» » S7 Interface			
Standalone	No		
S7 Output Value 1	Totalizer 1		
S7 Output Value 2	Totalizer2/batch		
S7 Lifebit Timeout	0		ms

Figure 10-10 S7 interface

Changing from S7 - DB\_FLOW\_PARA: See DR7 Interface parameters

10.16 Changing parameters in write protection mode with SIMATIC PDM

» » » S7 Alarms		
S7 Process Alarm 0 Assignment	ST BATCHING (G)	
S7 Process Alarm 1 Assignment	Alarm disabled	
S7 Process Alarm 2 Assignment	Alarm disabled	
S7 Process Alarm 3 Assignment	Alarm disabled	
S7 Process Alarm 4 Assignment	Alarm disabled	
S7 Process Alarm 5 Assignment	Alarm disabled	
S7 Process Alarm 6 Assignment	Alarm disabled	
S7 Process Alarm 7 Assignment	Alarm disabled	

Figure 10-11 S7 alarms

Changing from S7 - DB\_FLOW\_PARA: See DR7 Interface parameters

10.16.1 Changing parameters in write protection mode from S7 when mass flow is 0

Table 10-5 SIFLOW commands

Code	Name	Description
10	CMD_TOTALIZER_2_RESET	Reset totalizer 2 to zero and restart counting
13	CMD_TOTALIZER_2_PRESET	Preset totalizer 2 to the value totalizer2_preset_value and restart counting

10.16.2 Reading actual hardware and firmware versions from SIFLOW

From PDM

Step 1: Go to Device\Upload to PG/PC to upload all parameters from SIFLOW.

Now the hardware and firmware versions can be read.

» » Device	
Manufacturer	Siemens
Product Name	SIFLOW FC070
Order Number	7ME4 120-2DH21-0EA0
Serial Number	LBA4000004
→ Firmware Revision	V2.0.0
→ Hardware Revision	2
EDD Version	1.01.01
Firmware Checksum	0xC6290E16
Firmware Size	0x64410600
Firmware Name	SIFLOW_Appl_V2-0-0
Firmware Compilation Date	10/15/2010

Figure 10-12 Reading hardware and firmware versions from PDM

## From S7

Step 1: Read all parameters using command 649.

Now the hardware and firmware versions can be read. The information can be found in the following data records:

DR32-34: Transmitter, sensor and customer data

Actual hardware version can be read from tag: *transmitter\_hw\_ver*.

Actual firmware version can be read from tag: *fw\_version*.

## 10.17 CT parameters

A custody transfer application can be set up in two different ways.

1. Using Digital output with phase shift
2. Using the SIFLOW CT OCX ActiveX component in a SIMATIC HMI panel.

For additional information, see the S7 data record descriptions (Page 201).

The CT parameters are listed in the following tables:

CT parameters when using SIFLOW with Redundancy pulse 90° / 180° output (Page 239).

CT parameters when using SIFLOW with Redundancy frequency 90° / 180° output (Page 241).

DR39 CT parameters when using SIFLOW with OCX (Page 243).

## 10.18 Checking that SIFLOW is in CT mode

There are two possible ways of checking that SIFLOW Ex is in CT mode.



## 1. Using PDM

In "Process variables" (System status).

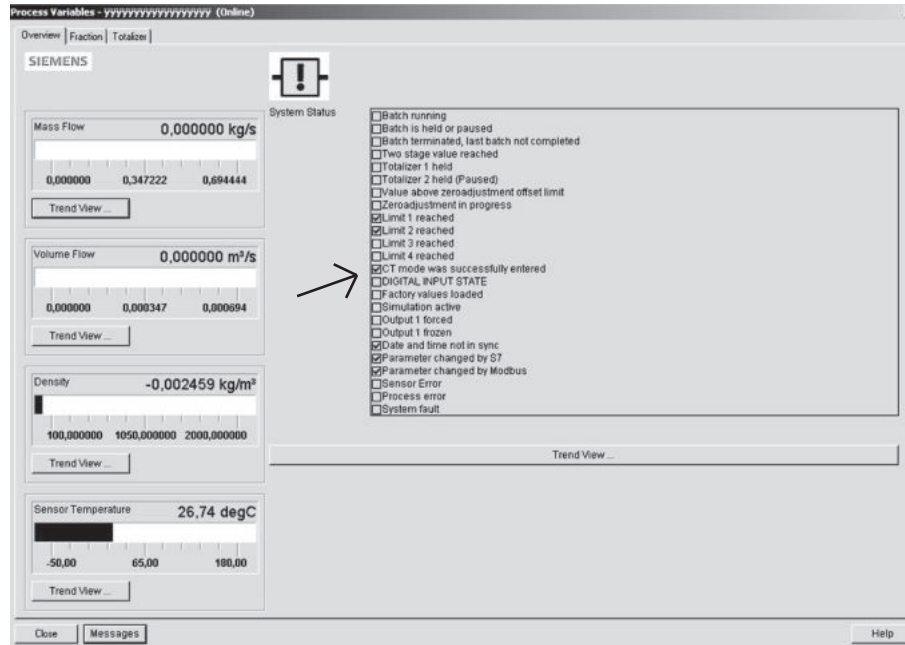

Figure 10-13 CT mode check

## 2. Using S7

Read the tag ST\_CT\_MODE in the system status word (SC\_STATUS). If the tag value is 1, CT mode is enabled.

See also System status information.



## Functions

### 11.1 Zero point adjustment

#### Zero point adjustment function

The zero point adjustment settings of the flowmeter is done by using the parameters in the following table:

Parameter	Label	Description
DR3: zero_adjust_time	Zero adjust time	Duration of zero adjust setting in [s] (for progress, see DR30 → zero_adjust_progress) 0 ... 65 535 s
DR3: zero_sigma_limit	Zero sigma limit	Max. zero sigma permitted by automatic zero adjust setting
DR3: zero_offset_limit	Zero offset limit	Max. zero offset of automatic zero adjust
DR11: zero_offset_preset_value	Zero offset preset value	Default settings for the zero adjust function: Value in mass flow units

#### Automatic zero point adjustment

The SIFLOW FC070 function module measures and calculates the correct zero value automatically.

Before zero point adjustment is instigated, the pipe must be full and at an absolute flow rate of zero. When zero adjust is instigated using the command `CMD_START_AUTO_ZERO_ADJUST`, the mass flow values are acquired and totaled for the configured period (DR3: zero\_adjust\_time), and an average value is calculated using the following formula:

#### Sensor zero value

Average of N flow values

$$\bar{x} \equiv \frac{\sum_{i=1}^N x_i}{N}$$

$x_i$  is an instantaneous flow value

$N = \text{Duration} * \text{SampleFreq}$

$\text{SampleFreq} = 10^6/2^{15}$

11.1 Zero point adjustment

The **zero point adjustment time** DR3: zero\_adjust\_time determines the duration of the automatic zero adjustment. The standard value, 30 s, is normally sufficient for a stable zero measurement.

**Note**

**Extremely small flow quantity**

If the flow quantity is extremely small, extremely precise measurement is necessary. In this case, a long integration time can be selected for improved zero point measurement.

During the zero point adjustment procedure, the status bit ST\_ZERO\_ADJUST\_IN\_PROGRESS is set and the progress of the procedure can be scanned as a percentage in DR31: zero\_adjust\_progress.

After completion of the DR3: zero\_adjust\_time, the standard deviation DR31: zero\_sigma is calculated in accordance with the following formula:

**Zero point sigma**

Standard deviation of N values

$$s \equiv \sqrt{\frac{\sum_{i=1}^N (x_i - \bar{x})^2}{N - 1}} = \sqrt{\frac{-N\bar{x}^2 + \sum_{i=1}^N x_i^2}{N - 1}}$$

The zero point sigma contains important feedback on the homogeneity of the fluid, e.g. on the presence of bubbles or particles.

The standard deviation must be within a window related to the determined zero point x.

- When DR31: zero\_sigma is greater than the configured limit (DR3: zero\_sigma\_limit), the error PE\_ZEROADJ\_SIGMA\_LIMIT is set.  
In this case, the user should check that the pipe is full and that the flow rate is absolute zero. The zero point adjustment should then be repeated.
- When the zero point exceeds the value DR3: zero\_offset\_limit, the error PE\_ZEROADJ\_OFFSET\_LIMIT and the system status bit ST\_ZERO\_ADJUST\_OFFSET\_LIMIT\_EXCEEDED are set. The status bit ST\_ZERO\_ADJUST\_OFFSET\_LIMIT\_EXCEEDED is reset by the next CMD\_START\_AUTO\_ZERO\_ADJUST command.
- When DR31: zero\_sigma is less than DR3: zero\_sigma\_limit, the zero point is valid and is automatically stored in the DR31: zero\_offset\_value and in the SENSORPROM as the new zero point for the sensor. It remains stored in the case of a power failure.

On completion of the zero point adjustment procedure, the status bit ST\_ZERO\_ADJUST\_IN\_PROGRESS is reset and DR30: zero\_adjust\_progress is set to 0.

During the zero point adjustment procedure, no parameter changes are accepted.

**Manual zero point adjustment**

After a CMD\_ZERO\_OFFSET\_VALUE\_PRESET, the DR11: zero\_offset\_preset\_value is stored in the DR31: zero\_offset\_value and in the SENSORPROM as the new zero point for

the sensor. It is not checked whether DR11: zero\_offset\_preset\_value is greater than DR3: zero\_offset\_limit.

### See also

DR3 Basic settings (R/W) (Page 204)

DR11 Process value default settings (R/W) (Page 222)

DR31 Service information (R) (Page 228)

## 11.2 Low flow cut-off

In certain applications, no flow signals under a certain flow level are desired (low-flow cut-off). A lower limit between 0 and 10 % can be set for using the process value by the output and the totalizer by means of the parameter DR3: low\_flow\_cut\_off.

This percentage is related to the maximum setting of the mass flow DR3: massflow\_max.

The low-flow cut-off function influences the following process values:

- Mass flow
- Volume flow
- Fraction A flow
- Fraction B flow
- Totalizer 1
- Totalizer 2 / batch

### See also

DR3 Basic settings (R/W) (Page 204)

## 11.3 Empty pipe monitoring

"Empty pipe detection" can be set using parameter DR3: empty\_pipe\_detection\_on\_off. This function is used for detecting an empty pipe.

A lower limit for the density of the fluid can be set using parameter DR3: empty\_pipe\_limit. When the value falls below this, the process error PE\_EMPTY\_PIPE is reported.

No hysteresis is processed for this limit.

PARAMETER	LABEL	DESCRIPTION
DR3: empty_pipe_detection_on_off	Empty pipe detection on / off	Function for empty pipe detection On/Off <ul style="list-style-type: none"> <li>• 0=Off</li> <li>• 1=On</li> </ul>
DR3: empty_pipe_limit	Empty pipe limit	Error when density is lower than the empty pipe limit -20000.0 ... +20000.0 in steps of 0.1

**See also**

DR3 Basic settings (R/W) (Page 204)

## 11.4 Noise filter

### Noise filter function

The SIFLOW FC070 module carries out the signal processing in the Coriolis ASIC using a patented FFT algorithm (FFT = Fast Fourier Transformation). Sensor signals that are prone to interference can be filtered using this technology. If, for example, a strongly pulsating flow, changing pump frequencies or large pressure variations occur at the sensor, this can in certain cases result in noise voltages in the sensor signals and therefore measurement errors.

### Noise filter settings

These measurement errors can be reduced by increasing the filtering parameter DR3: noise\_filter. Setting 5 represents the maximum possible filtering level and setting 1 is the minimum possible filtering level.

- 1 = min.
- 2
- 3
- 4
- 5 = max.

**See also**

DR3 Basic settings (R/W) (Page 204)

## 11.5 Scaling and unit conversion

### Min. / max. values (scaling)

The min. / max. values are set by the parameters in DR3:

Max. process values	Default setting	Default unit
massflow_max	31.25 if no SENSORPROM is connected, otherwise read from SENSORPROM	kg/s
volumeflow_max	0.001556 if no SENSORPROM is connected, otherwise read from SENSORPROM	m <sup>3</sup> /s
density_max	2000	kg/m <sup>3</sup>
sensor_temperature_max	180 °C if no SENSORPROM is connected, otherwise read from SENSORPROM	°C. SI unit: K -205 ... +250 °C
fraction_A_flow_max	31.25 kg/s or 0.001556 m <sup>3</sup> /s if no SENSORPROM is connected, otherwise read from SENSORPROM	kg/s
fraction_B_flow_max	31.25 kg/s or 0.001556 m <sup>3</sup> /s if no SENSORPROM is connected, otherwise read from SENSORPROM	kg/s
percent_fraction_a_max	1,0	1/100 %, e.g. value 0.8 = 80 % 0% ... +2900%

Process value min.	Default setting	Default unit
massflow_min	0 s if no SENSORPROM is connected, otherwise read from SENSORPROM	kg/s
volumeflow_min	0 s if no SENSORPROM is connected, otherwise read from SENSORPROM	m <sup>3</sup> /s
density_min	100	kg/m <sup>3</sup>
sensor_temperature_min	-50 if no SENSORPROM is connected, otherwise read from SENSORPROM	°C. SI unit: K -250 ... +250 °C
fraction_A_flow_min	0 if no SENSORPROM is connected, otherwise read from SENSORPROM	kg/s
fraction_B_flow_min	0 if no SENSORPROM is connected, otherwise read from SENSORPROM	kg/s
percent_fraction_a_min	0	e.g. value 0.05 = 5 % 0% ... +2900%

With the exception of the value for fraction A, the values are dependent on the pipe diameter of the sensor used.

11.5 Scaling and unit conversion

The min. / max. values in DR3 are primarily used for the scaling of the process values. The range between min. and max. is thereby related to the display range of the ASIC process value, whereby absolute values are generated.

**Note**

The parameter DR3: massflow\_max also serves as the upper monitoring limit for the value DR30: massflow. Monitoring is carried out in the ASIC. If the maximum value is exceeded, the ASIC sets the STATUS\_WL\_QMAX\_OVERLOAD bit in the ASIC status; this results in the error PE\_FLOW\_SATURATED.

**Note**

The parameters DR3: sensor\_temperature\_max and DR3: sensor\_temperature\_min are also used as monitoring limits for the value from DR30: sensor temperature. Monitoring is carried out in the ASIC. If a limit is exceeded, the ASIC sets the STATUS\_WL\_TEMP\_ERROR bit in the ASIC status; this then leads to the error PE\_TEMP\_MAX or PE\_TEMP\_MIN.

**Unit conversion**

The units at the external SIMATIC and MODBUS communications interfaces can be set for every process value using the following parameters:

Process value	Unit ID (default = SI)
massflow_unit	0...255 (SI = kg/s)
volumeflow_unit	0...255 (SI = m <sup>3</sup> /s)
density_unit	0...255 (SI = kg/s or m <sup>3</sup> /s)
temperature_unit	0...255 (SI = K)
totalizer_1_unit	0...255 (SI = kg or m <sup>3</sup> )
totalizer_2_unit	0...255 (SI = kg or m <sup>3</sup> )
density_unit	0...255 (SI = kg/m <sup>3</sup> )
batch_unit	0...255 (SI = kg or m <sup>3</sup> )
pulse_amount_unit	0...255 (SI = kg or m <sup>3</sup> )

The values affected by the unit are converted at both interfaces from the external unit to SI unit on receiving and are converted from the SI unit to the external unit on sending.

The conversion factors are stored in a table of constants in the firmware. The units tables are documented in the appendix.

If the SI unit is also configured at the external interfaces, a conversion is not carried out.

**Note**

The SI unit is always used within the function module (ASIC, SENSORPROM, etc.).



**See also**

DR3 Basic settings (R/W) (Page 204)

## 11.6 Limit value monitoring

### Limit monitoring function (4 limits)

A total of 4 limits can be assigned in any order for the selectable process values  
DR12: limit x\_selection.

1, 2, 3 or all 4 limits can be assigned to a process value to be monitored.

### Example

4 limits for mass flow (2 low, 2 high)

- 2 limits for mass flow (1 low, 1 high)  
2 limits for volume flow (1 low, 1 high)
- 1 limit for mass flow (1 high)  
1 limit for volume flow (1 high)  
1 limit for density (1 low)  
1 limit for sensor temperature (1 high)

The limit DR12: limit x\_setpoint and the hysteresis DR12: limit x\_hysteresis are configured as a percentage of the maximum value of the selected process value (e.g. for mass flow: DR3: massflow\_max).

The parameter DR12: limit x\_direction defines the type of the limit. There are low limits and high limits.

- In case of a low limit, the corresponding limit bit ST\_LIMIT\_x in the system status is set when the process value undershoots the setpoint. The status bit is reset if the process value exceeds the setpoint plus hysteresis.
- In case of a high limit, the corresponding limit bit ST\_LIMIT\_x in the system status is set when the process value overshoots the setpoint. The status bit is reset if the process value undershoots the setpoint minus hysteresis.

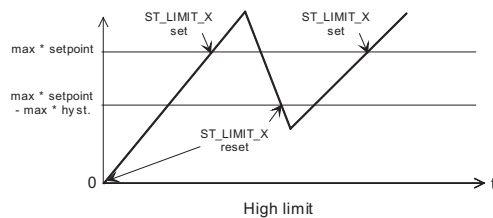
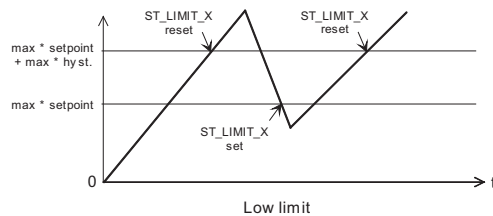

max e.g. massflow\_max or volumeflow\_max, according to the configured application

Figure 11-1 Limits

The only exception is when a totalizer is selected for **limit\_x\_selection**. In this case the hysteresis and setpoint are absolute values!

Tripping of an S7 process interrupt for a set or reset limit bit can be activated in the status using **DR7: s7\_pral\_x\_assignment**. This ensures that a fast response to a limit overshoot occurs in the PLC program.

**See also**

DR12 Limit default settings (R/W) (Page 224)

## 11.7 Simulation

### Simulation function

Various values in the system can be set to configured simulation values by **DR10: simulation\_enable**. Following options are available:

- Simulate mass flow value
- Simulate volume flow value
- Simulate density value
- Simulate sensor temperature

- Simulate fraction A percent
- Simulate output 1
- Simulate output 1 frequency
- Simulate output 2
- Simulate output 2 frequency
- Simulate input value
- Simulate error

As soon as at least one value is simulated (i.e. at least one bit in DR10: simulation\_enable) is set, the yellow SIM LED lights up and the system status bit ST\_SIMULATION\_ACTIVE is set.

The simulation can be activated at any time over SIMATIC or MODBUS.

The other interface in each case is informed about the activation by means of the status ST\_SIMULATION\_ACTIVE.

The currently simulated values can be read out in DR10: simulation\_enable.

### Possible values

Possible values for DR10: simulation\_enable:

SIMULATION_OFF	(WORD) 0x0000
SIMULATION_MASSFLOW_ENABLE	(WORD) 0x0001
SIMULATION_VOLUMEFLOW_ENABLE	(WORD) 0x0002
SIMULATION_DENSITY_ENABLE	(WORD) 0x0004
SIMULATION_SENSOR_TEMP_ENABLE	(WORD) 0x0008
SIMULATION_FRACTION_A_PERCENT_ENABLE	(WORD) 0x0040
SIMULATION_OUTPUT_1_ENABLE	(WORD) 0x0080
SIMULATION_OUTPUT_2_ENABLE	(WORD) 0x0100
SIMULATION_INPUT_ENABLE	(WORD) 0x0200
SIMULATION_ERROR_NO_ENABLE	(WORD) 0x0400

For mass flow, volume flow, density and sensor temperature, the simulated value has to be entered in the correct units.

### Example

Simulating mass flow = 1 kg/s:

- DR10: simulation\_enable = 0x0001
- DR10: simulation\_value\_massflow = 1.0
- DR2: massflow\_unit = 0 (SI, kg/s)

For simulating percent\_fraction\_a, the percentage value has to be entered, e.g. for simulating a fraction flow A of 35%:

11.7 Simulation

- DR10: simulation\_enable = 0x0040
- DR10: simulation\_value\_percent\_fraction\_a = 35

The result for fraction A is 35% of the measured mass flow (if mass flow is selected for the fraction).

The result for fraction B is automatically calculated as 65% (100% minus 35%) of the measured mass flow (if mass flow is selected for the fraction).

**Output simulation**

Both outputs can be simulated via the force function of the outputs in the ASIC.

Possible values for **DR10: simulation\_value\_output\_1** or **2**:

Output low	0
Output high	1
Output frequency	2

Possible values for **DR10: simulation\_value\_output\_1(2)\_frequency**:

- 0...12500

Activation of the simulation is rejected if a batch procedure is currently running on an output. This applies to both outputs if a two-stage batch or quadrature is running. The activation must then be repeated at a later time.

Only the operation of the outputs via the SIMATIC IO area s7\_control\_signals ->digital\_output is accepted as an emergency stop circuit.

**Input simulation**

The level of the input is not read from the HW input but is simulated in the firmware. Edge/level evaluation at hardware input **DR6: input\_inversion** and the following firmware filtering **DR6: input\_filter\_time** are omitted. The SF reaction **DR6: digital\_input\_sf\_reaction** is not taken into account either. The function set in the configuration **DR6: digital\_input\_function** is then executed.

**Error simulation**

If the simulation of an error is activated by **DR10: simulation\_enable**, the error entered under **DR10: simulation\_value\_error\_no** is simulated as a set error. If simulation is deactivated with **DR10: simulation\_enable**, the error is reported as reset.

Range: only SE and PE errors, no HE errors.

**See also**

DR10 Simulation data (R/W) (Page 220)

## 11.8 Output

### 11.8.1 Digital output

#### Two digital outputs

The Coriolis ASIC controls 2 digital outputs. Seven modes can be set for outputs in the Coriolis ASIC:

- Pulse (only output 1)
- Frequency (only output 1)
- Phase shift pulse (outputs 1 + 2) 90°
- Phase shift pulse (outputs 1 + 2) 180°
- Phase shift frequency (outputs 1 + 2) 90°
- Phase shift frequency (outputs 1 + 2) 180°
- Two-stage batch (outputs 1 + 2)
- Batch (only output 1)

#### Output 1

Output 1 can be used for the variable:

- Process value as frequency-proportional signal
- Process value as quantity-dependent pulse repetition
- Quantity-dependent valve control (batch)

#### Output 2

Output 2 is not an independent output with the same functions as output 1, but can be used as an additional output for the following functions.

- Two-stage batch
- Phase shift pulse (90° or 180°)
- Phase shift frequency (90° or 180°)

#### Control of the outputs

Both outputs are low at the ASIC during a reset. The digital outputs controlled by the ASIC can be overwritten by the firmware and directly controlled over the port pins of the controller. This is necessary in the following cases:

- during startup until the system (sensor) is stable (approx. 40 s)
- in the phase of power-down

- when the firmware has to control the outputs directly (e.g. OD signal)
- when the user wants to control the outputs directly from SIMATIC P-bus

Parameters are used to specify how the outputs should be set in the case of a set OD signal (S7 CPU STOP) or on failure of the P-bus 5 V power supply.

Additionally, the reaction with respect to the outputs in the case of a set system fault (SF) can be configured (**DR5: digital\_output\_sf\_reaction**).

The possibility of direct control is not used for the simulation of the output; the force function of the ASIC is used here.

In normal operation, the condition of both outputs is shown on LEDs DO1 and DO2.

## 11.8.2 Pulse output

### Pulse output function

The pulse output function supplies a pulse at output 1 with the configurable pulse width DR5: pulse\_width and a pulse spacing that is proportional to the selected process value DR5: pulse\_value\_selection.

The pulse is always output according to the flow of a configurable delta quantity DR5: pulse\_mass\_or\_volume\_amount.

$$\text{Pulse length} = \frac{\text{pulse\_mass\_or\_volume\_amount}}{\text{Measured value}}$$

### Example

Measured value according to pulse\_value\_selection

DR5: pulse\_value\_selection = mass flow

DR3: massflow\_max = 10 kg/s

DR5: pulse\_mass\_or\_volume\_amount = 1 kg

DR5: pulse\_width = 1 ms

DR30: massflow = 1 kg/s (constant)

#### Result:

- Pulse length = 100 ms
- Output frequency = 10 pulses per second with a pulse width of 1 ms

The pulse frequency generator for the output in the ASIC can supply a frequency between 0.1 Hz and 12 kHz with a resolution of 0.06 Hz.

**DR5: pulse\_direction** can be used to set whether the pulse output should only output positive (upward) or bidirectional (upward/downward) process values.

## See also

DR5 Digital output (R/W) (Page 210)

### 11.8.3 Frequency output

#### Frequency output function

The frequency output function supplies a frequency (50% pulse/pause ratio) at output 1 that is proportional to the selected process value **DR5: frequency\_value\_selection**.

The pulse frequency generator for the output in the ASIC can supply a frequency between 0.1 Hz and 12 kHz with a resolution of 0.06 Hz.

The following maximum frequencies are selectable by means of parameterization:

- 0 = 10 kHz
- 1 = 5 kHz
- 2 = 1 kHz
- 3 = 500 Hz

The configured frequency **DR5: frequency\_max** corresponds to 100%.

$$\text{Frequency} = \frac{\text{Measured value}}{\text{Max. value}} \times \text{frequency\_max}$$

#### Example

Measured value and max. value according to frequency\_value\_selection::

- DR5: frequency\_value\_selection = mass flow
- DR3: massflow\_max = 10 kg/s
- DR5: frequency\_max = 1 kHz
- DR30: massflow = 5 kg/s

Result:

- Output frequency = 500 Hz with 50% pulse/pause ratio

DR5: frequency\_direction can be used to set whether the frequency output should only output positive (upward) or bidirectional (upward/downward) process values.

DR5: frequency\_time\_constant is used to smooth the output frequency.

## See also

DR5 Digital output (R/W) (Page 210)

## 11.8.4 Phase shift output

### Phase shift function (pulse or frequency at outputs 1 and 2)

Via the phase shift function, the two outputs can also display whether there is a forward or backward flow.

The phase shift function can be activated in pulse and frequency modes.

- In phase shift pulse mode, output 1 behaves just as in normal pulse mode. Output 2 generates a pulse with the same frequency as output 1, but shifted by half a pulse length. For a positive process value, output 2 is delayed by half a pulse length with reference to output 1; for a negative process value, output 2 leads by half a pulse length.
- In phase shift frequency mode, output 1 behaves just as in normal frequency mode. Output 2 generates the same frequency as output 1, but shifted by a quarter of the period. For a positive process value, output 2 is delayed by a quarter period with reference to output 1; for a negative process value, output 2 leads by a quarter period.

## 11.8.5 Batch output

### Batch function (dosing)

The digital output can be set for the batch function by setting the parameter DR5: digital\_output\_function. The batch function is used for measuring the quantity of gas or fluid. Thereby e.g. a valve is opened and closed via the digital output.

Measuring of an outflowing quantity is started by the CMD\_BATCH\_START command which sets the output to High which opens the valve.

When a preset mass or volume DR11: batch\_quantity is reached, the valve is closed via the digital output (= 0). The batch procedure is complete. A new batch procedure can be started 150 ms after the start of the preceding batch procedure. There must be a wait time of at least 50 ms between the batch stop and the new batch start.

The process value that serves as input for the batch function is selected via DR5: batch\_value\_selection:

- 1 = mass flow
- 2 = fraction A
- 3 = fraction B
- 4 = volume flow

The batch output is reset to 0 if the frequency pulse generator is reset.

The batch compensation function (offset) allows a fixed amount DR11: batch\_compensation to be added/subtracted to compensate for valve delays.

An additional compensation value is the time constant DR11: batch\_lead\_constant which is loaded when the output function for batch is reconfigured. The lead constant (time constant) DR11: batch\_lead\_constant is handled in the unit [s].

This compensation takes into account flow variations.



### Example:

Setting the parameter `batch_lead_constant`

- Set all compensations to zero (DR11: `batch_compensation` and DR11: `batch_lead_constant`).
- Enter the desired amount **DR11: `batch_quantity`** (M-wanted e.g. 25 kg), and start the batch process.
- Observe the flow, reading the flow **DR30: `massflow`** just before the batch stop (Q-end, e.g. 5000 kg/h).
- Note the amount that the totalizer **DR30: `totalizer_2_batch`** indicates and read the amount after the totalizer stops (M-real e.g. 25.5 kg).
- Calculate the lead constant as:
  - **LeadConst** = (M-real - M-wanted) / Q-end.

---

#### Note

LeadConst is specified in seconds

---

**For the example, this will result in:**

$\text{LeadConst} = (25.5 \text{ kg} - 25 \text{ kg}) / (5000 \text{ kg/h}) = 0.0001 \text{ h} = 0.36 \text{ seconds.}$

- Enter this value as lead constant. This is a good starting point which only requires small adjustments to be made. SIFLOW FC070 is now to fill 25 kg, even if the flow changes. (If the valve closing time also changes, this is not the case! The lead constant can only compensate real changes in flow.)

### Batch timeout monitoring

The batch timeout monitoring checks whether the batch procedure has been terminated within the set time DR5: `batch_time_max`. If this is not the case, an error `PE_BATCH_TIMEOUT` is generated. The batch timeout monitoring can be switched on and off by means of the parameter DR5: `batch_time_error_on_off`.

### Batch overrun monitoring

The batch overrun monitoring checks that the flow quantity through the valves in the closed state does not exceed a preset quantity DR5: `batch_overrun_error_quantity`. This function can therefore detect a valve malfunction (non-closure) caused by a blockage, wear, etc. If the quantity is exceeded, the error `PE_BATCH_OVERRUN` is signaled. The batch overrun monitoring can be switched on and off by means of the parameter DR5: `batch_overrun_on_off`.

### Batch counter

The batch counter indicates how the batch quantity DR11: batch\_quantity changes in the course of a batch procedure. Totalizer 2 serves as a batch counter  
DR30: totalizer\_2\_batch.

- If DR5: batch\_counter\_up\_down = up is selected, the batch counter counts up from 0 up to the selected quantity DR11: batch\_quantity.
- If DR5: batch\_counter\_up\_down = down is selected, the batch counter counts down from DR11: batch\_quantity to 0.

### Batch commands

A batch procedure can be started, halted, continued or stopped completely using the appropriate commands

- CMD\_BATCH\_START
- CMD\_BATCH\_HOLD
- CMD\_BATCH\_CONTINUE
- CMD\_BATCH\_STOP

The current state of the batch procedure can be seen in the system status window.

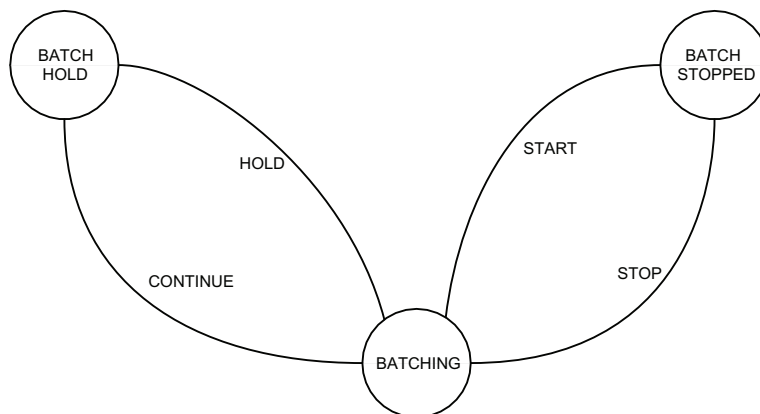

Figure 11-2 Batching state chart

### Batch status

The batch status is indicated by the following status bits in the system status:

- ST\_BATCHING
- ST\_BATCH\_HOLD
- ST\_BATCH\_STOPPED
- ST\_BATCH\_TWO\_STAGE\_REACHED

The number of batch procedures that have been started is counted in the DR31: batch\_cycle\_counter. The DR31: batch\_cycle\_counter can be set to 0 using the command CMD\_BATCH\_CYCLE\_COUNTER\_RESET.

The On level of the output for the batch function can be defined using parameter DR5: batch\_output\_polarity.

No parameters that influence the batch procedure are accepted while the batch is being processed.

### See also

DR5 Digital output (R/W) (Page 210)

DR11 Process value default settings (R/W) (Page 222)

## 11.8.6 Two-stage batch output

### Two-stage batch function (level at outputs 1 + 2)

The two-stage batch function is used for implementing coarse/fine metering of the quantity to be filled. Both digital outputs are required for this.

On starting the batch procedure, both outputs are first activated together (high). This ensures that the amount is filled quickly (2 valves). This is indicated in the system status by the bit ST\_BATCHING.

After DR11: batch\_two\_stage\_level in % of DR11: batch\_quantity has been reached, output 2 is switched off by the ASIC. This is indicated by the system status bit ST\_BATCH\_TWO\_STAGE\_REACHED.

The remaining amount to be filled is controlled by the ASIC using fine metering, and only via output 1. When 100% of the quantity to be filled DR11: batch\_quantity has been reached, output 1 is also switched off and both status bits ST\_BATCHING and ST\_BATCH\_TWO\_STAGE\_REACHED are reset to indicate that the batch procedure has been completed.

For the two-stage batch function, both output paths in the ASIC are set identically with the exception of the fill quantity. The different amounts result in the different switch-off times for the two outputs.

No parameters that influence the batch procedure are accepted while the batch is being processed.

### See also

DR11 Process value default settings (R/W) (Page 222)

### 11.8.7 Freezing and forcing outputs

#### Force function

Following the command `CMD_FORCE_OUTPUT_ON`, both outputs are switched to a frequency specified by `DR6: force_frequency_output_value` and `DR5: frequency_max`. The set output frequency is `force_frequency_output_value * frequency_max`. A `CMD_FORCE_OUTPUT_OFF` command switches back to the frequency calculated from the measured value.

#### Freeze function

Following a `CMD_FREEZE_OUTPUT_ON` command, the actual output frequencies on both outputs are frozen to ensure that they cannot be changed by the measured value. A `CMD_FREEZE_OUTPUT_OFF` command switches back to the frequency calculated from the measured value.

Both commands (force and freeze) will only be executed when the outputs are parameterized for frequency.

## 11.9 Input

### 11.9.1 Digital input

The digital input is an interrupt input for the controller. This ensures the shortest response time possible.

The configured firmware filter time **DR6: input\_filter\_time** is started after detecting the configured edge transition. The edge transition from Low to High is the active edge; when inversion is configured with **DR6: input\_inversion** = on, the edge transition from High to Low is significant. The event is only accepted if the input level remains unchanged during the filter time. This is also indicated by the DI1 LED. The level of the input signal is also indicated in the system status bit `ST_DIGITAL_INPUT_STATE`.

#### Digital input functions

The event triggers a corresponding command depending on the configured function `DR6: digital_input_function`.

The following functions can be configured:

Input function	Edge / level	Command
0 = off	---	---
1 = start batch	Edge ↑	<code>CMD_BATCH_START</code>
2 = stop batch	Edge ↑	<code>CMD_BATCH_STOP</code>
3 = start / stop batch	Level 1 Level 0	<code>CMD_BATCH_START</code> <code>CMD_BATCH_STOP</code>

Input function	Edge / level	Command
4 = hold / continue batch	Level 1 Level 0	CMD_BATCH_HOLD CMD_BATCH_CONTINUE
5 = reset totalizer 1	Edge ↑	CMD_TOTALIZER_1_RESET
6 = reset totalizer 2	Edge ↑	CMD_TOTALIZER_2_RESET
7 = reset totalizers (T1 and T2)	Edge ↑	CMD_TOTALIZER_1_2_RESET
8 = zero adjust	Edge ↑	CMD_START_AUTO_ZERO_ADJUST
9 = force output	Level 1 Level 0	CMD_FORCE_OUTPUT_ON CMD_FORCE_OUTPUT_OFF
10 = freeze output	Level 1 Level 0	CMD_FREEZE_OUTPUT_ON CMD_FREEZE_OUTPUT_OFF

The way in which the digital input is to be processed for a set system error (SF) can be set using the parameter DR6: digital\_input\_sf\_reaction.

The state of the digital input after firmware filtering is indicated by status bit ST\_DIGITAL\_INPUT\_STATE.

## 11.10 Process Information

### 11.10.1 Process values

Process information is information that can only be read. It can be read out of the function module via SIMATIC and MODBUS.

The separate items of process information are collected for SIMATIC in data record DR30 and are stored individually for MODBUS under the respective MODBUS address.

Process information is generated in the SIFLOW function module from the ASIC process values and the associated status and is updated in the acquisition cycle of the Coriolis ASIC (approx. 33 ms).

The process values are:

- System status
- Mass flow
- Volume flow
- Density
- Sensor temperature
- Fraction A flow
- Fraction B flow
- Percent fraction A
- Totalizer 1
- Totalizer 2 batch

### Process value update cycle

The data are made available as soon as possible. The update cycle is synchronous with the ASIC update cycle. Triggered by the new data, reading from the ASIC and processing of process values are performed every 33 ms.

The cyclic arrival of the new data (33 ms) is monitored by the firmware. When data are not received in two cycles, an ASIC error SE\_ASIC\_WATCHDOG is generated.

Before the transfer buffer is saved for the SIMATIC and MODBUS interface, the values are converted to the configured unit (national dimension unit that is used outside the SIFLOW function module).

### 11.10.2 Fraction

The fraction is determined as part of a mixture. This mixture, e.g. of a fluid, comprises two components A + B which can be determined individually.

If the flowmeter is ordered with a specific fraction, e.g. °Brix, it can determine the percentage concentration percent\_fraction\_A of sugar in a solution of water (B) + sugar (A).

#### Calculating the fraction

percent\_fraction\_A is a percentage calculated using the following formula:

percent\_fraction\_A [%] = fraction\_offset + fraction\_factor \* %fraction  
where:

$$\begin{aligned} \% \text{ fraction} &= \text{Intercept} \\ &+ x_1 * T + x_2 * T^2 \\ &+ (x_3 + x_4 * T + x_5 * T^2) * \rho \\ &+ (x_6 + x_7 * T + x_8 * T^2) * \rho^2 \\ &+ (x_9 + x_{10} * T + x_{11} * T^2) * \rho^3 \end{aligned}$$

- T = FractionTemp
- ρ = FractionDens
- x<sub>n</sub> = DR33: fraction\_calibration\_X0 ... X11
- Intercept = x<sub>0</sub>

The **DR9: fraction\_factor** is factory-set to 1.000 and the DR9: fraction\_offset is set to 0. If you want to increase the percentage concentration in the flowmeter by 0.5 %, you must increase the **DR9: fraction\_factor** to 1.005. Following this change, the flowmeter indicates an increase in concentration of 0.5%.

One of two input values can be used when calculating the fraction: mass flow or volume flow. The **DR33: fraction\_value\_selection** parameter is factory-set in the SENSORPROM and can only be scanned by the module firmware.

The fraction flow values are calculated according to the following formula:

**Mass flow:**
$$\text{fraction\_A\_flow} = \text{massflow} * \text{percent\_fraction\_A}$$
$$\text{fraction\_B\_flow} = \text{massflow} * (1 - \text{percent\_fraction\_A})$$
**Volume flow:**
$$\text{fraction\_A\_flow} = \text{volumeflow} * \text{percent\_fraction\_A}$$
$$\text{fraction\_B\_flow} = \text{volumeflow} * (1 - \text{percent\_fraction\_A})$$
**See also**

DR9 Sensor properties (R/W) (Page 218)

**11.10.3 Totalizer**

SIFLOW FC070 has 2 independent totalizers that can be used for the summation of mass flow, fraction A, fraction B or volume flow.

You can use parameters to set which value is to be totalized (`totalizer_x_selection`) as well as the flow direction for the count (`totalizer_x_direction`).

The totalizers have a 64-bit counter in the firmware.

---

**Note**

Changing Totalizer x selection while the totalizer is running may lead to an undefined totalizer value shown as "NaN" (Not a Number). Therefore, it is recommended to hold and reset (see below) totalizer x before changing this parameter.

---

**Totalizer values**

The totalizer values are available as DOUBLE values and as FLOAT/REAL values. Both types can be read using the Modbus address. Only the REAL value DR30: `totalizer_1` or DR30: `totalizer_2_batch` is saved in DR30.

If there is a group error (SF), a decision is made via the `totalizer_x_fail_mode` parameter as to which value the totalizer should process. The firmware totalizer (64-bit) always continues to execute during an SF error. The totalizer value (48-bit) from the ASIC, which is most probably invalid, is no longer used as delta; a fixed value is used instead. This value can be the last valid value read out from the ASIC before the error, or it can be zero.

PARAMETER	LABEL	DESCRIPTION / VALUE RANGE
DR4: totalizer_1_selection	Totalizer 1 selection	<ul style="list-style-type: none"> <li>• 1 = mass flow</li> <li>• 2 = fraction A</li> <li>• 3 = fraction B</li> <li>• 4 = volume flow</li> </ul>
DR4: totalizer_1_direction	Totalizer 1 direction	<ul style="list-style-type: none"> <li>• 0 = negative (reverse: only backwards)</li> <li>• 1 = positive (forward: only forwards)</li> <li>• 2 = equal (net: + if forward / - if backward)</li> </ul>
DR4: totalizer_1_fail_mode	Totalizer 1 fail mode	<ul style="list-style-type: none"> <li>• 0 = RUN: Totalize using actual flow value</li> <li>• 1 = HOLD: Summation is halted (using zero)</li> <li>• 2 = MEMORY: Totalize using the last good value</li> </ul>
DR4: totalizer_2_selection	Totalizer 2 selection	<ul style="list-style-type: none"> <li>• 1 = mass flow</li> <li>• 2 = fraction A</li> <li>• 3 = fraction B</li> <li>• 4 = volume flow</li> </ul>
DR4: totalizer_2_direction	Totalizer 2 direction	<ul style="list-style-type: none"> <li>• 0 = negative (reverse: only backwards)</li> <li>• 1 = positive (forward: only forwards)</li> <li>• 2 = equal (net: + if forward / - if backward)</li> </ul>
DR4: totalizer_2_fail_mode	Totalizer 2 fail mode	<ul style="list-style-type: none"> <li>• 0 = RUN: Totalize using actual flow value</li> <li>• 1 = HOLD: Summation is halted (using zero)</li> <li>• 2 = MEMORY: Totalize using the last good value</li> </ul>
DR11: totalizer_1_preset_value	Totalizer 1 preset value	Unit for volume flow or mass flow according to the source selected
DR11: totalizer_2_preset_value	Totalizer 2 preset value	Unit for volume flow or mass flow according to the source selected

PARAMETER	LABEL	DESCRIPTION
DR30: totalizer_1	Totalizer 1	Unit and range according to source (mass flow or volume flow)
DR30: totalizer_2_batch	Totalizer 2 / batch	Unit and range according to source (mass flow or volume flow)

### Reset and preset of totalizers

The totalizers can be halted using the command `CMD_TOTALIZER_x_HOLD`. They are restarted by `CMD_TOTALIZER_x_CONTINUE`.

With the totalizer commands, the two totalizers can be handled individually or together.

When the function module starts up, the totalizer is halted initially until the sensor has completed its transient phase (approx. 40 s). The function module then starts, and the 64-bit totalizer values are stored in the FRAM before the restart.



COMMAND	LABEL	DESCRIPTION
CMD_TOTALIZER_1_RESET	Totalizer 1 reset	Reset totalizer 1 to zero, and restart count
CMD_TOTALIZER_1_HOLD	Totalizer 1 hold	Halt totalizer 1 (used in some cases when the pipes are being cleaned and summation must not include the cleaning agent)
CMD_TOTALIZER_1_CONTINUE	Totalizer 1 continue	Continue totalizer 1 after a halt
CMD_TOTALIZER_1_PRESET	Totalizer 1 preset	Preset totalizer 1 to the value of DR11: totalizer_1_preset_value, and restart count
CMD_TOTALIZER_2_BATCH_RESET	Totalizer 2 / batch reset	Reset totalizer 2 to zero, and restart count
CMD_TOTALIZER_2_HOLD	Totalizer 2 hold	Halt totalizer 2 (used in some cases when the pipes are being cleaned and summation must not include the cleaning agent)
CMD_TOTALIZER_2_CONTINUE	Totalizer 2 continue	Continue totalizer 2 after a halt
CMD_TOTALIZER_2_PRESET	Totalizer 2 preset	Preset totalizer 2 to the value of DR11: totalizer_2_preset_value, and restart count
CMD_TOTALIZER_1_2_RESET	Totalizer 1 and 2 reset	Reset totalizers 1+2 to zero and restart count
CMD_TOTALIZER_1_2_HOLD	Totalizer 1 and 2 hold	Halt totalizers 1+2 (used in some cases when the pipes are being cleaned and summation must not include the cleaning agent)
CMD_TOTALIZER_1_2_CONTINUE	Totalizer 1 and 2 continue	Continue totalizers 1+2 after a halt
CMD_TOTALIZER_1_2_PRESET	Totalizer 1 and 2 preset	Preset totalizer 1 to the value of DR11: totalizer_1_preset_value and totalizer 2 to the value of DR11: totalizer_2_preset_value, and restart count

### Totalizer 2 during a batch

As long as the batch function is activated in DR5: digital\_output\_function (= 5 or 6), totalizer 2 can only be used for the batch function. The parameters in DR4 and all commands (reset, preset, hold, continue) from the digital input, SIMATIC and Modbus are not taken into account. Totalizer 2 serves as a batch counter DR30: totalizer\_2\_batch.

### See also

DR30 Process values (R) (Page 228)

DR4 Totalizer (R/W) (Page 208)

DR11 Process value default settings (R/W) (Page 222)

## 11.11 Date and time

### Date and time

An absolute time in 8-byte SIMATIC format is kept in the SIFLOW FC070 function module (date and time).

#### BCD format:

- [0] year
- [1] month
- [2] day
- [3] hour
- [4] minute
- [5] seconds
- [6] milliseconds (100's and 10's positions)
- [7] milliseconds (1's position) + day of week (in lower 4 bits)

During startup, the date and time are set to the last value before power down (this is saved in the FRAM). This results in a jump in time for incoming messages that occur before the first positions for date and time (with reference to the actual time). However, the correct order is ensured for sorting the time of date-stamped information.

Messages are written into the error history of the diagnostics and firmware which allows the user to determine the time of power failure and the time setting.

The date and time can be set by the SIMATIC via **DR8: date\_and\_time**. The time can also be set by passing on the variables in the SIMATIC IO control signal. The variables are passed on here in the same manner as for MODBUS with a MODBUS address and a 4-byte value.

If the SIFLOW FC070 function module does not have a valid value for **DR8: date\_and\_time**, the **ST\_DATE\_AND\_TIME\_NOT\_SYNC** bit is set in the system status. The user can start transfer of the current SIMATIC CPU time using this information. The **ST\_DATE\_AND\_TIME\_NOT\_SYNC** bit is reset when **DR8: date\_and\_time** has been newly received.

The date and time should be reset by the user program each time the SIFLOW FC070 function module is restarted and reset at regular intervals to synchronize it with the date and time of the SIMATIC CPU. In this manner, synchronization between the time stamps of the CPU and the SIFLOW function module can be accurate to within seconds.

### Operating time counter

The SIFLOW function module has two operating time counters:

- Total operating time (**DR31: operating\_time\_total**)
- Operating time since the last power up (**DR31: operating\_time\_powerup**)

Both are kept as service information in DR31 and are updated every hour. The total operation time is kept powerfail-safe in the FRAM.

**See also**

DR7 Interface parameters (R/W) (Page 215)

## 11.12 Service information

Service information is information that can only be read. It can be read out of the function module via SIMATIC and MODBUS.

The separate items of service information are collected for SIMATIC in data record DR31 and are stored individually for MODBUS under the respective MODBUS address.

Service information provides information on the condition of the sensor and the transmitter. It is updated in the SIFLOW function module every 330 ms (3 Hz).

The service data are:

- Date and time
- Operating time total
- Operating time since power-up
- Driver signal
- Pick-up 1 amplitude
- Pick-up 2 amplitude
- Sensor frequency
- Transmitter temperature
- SENSORPROM installed
- Zero offset value
- Zero adjust progress
- Zero sigma
- Batch cycle counter

### Detection of inside temperature of enclosure

The SIFLOW FC070 function module contains a circuit for measuring the internal enclosure temperature.

The circuit guarantees a temperature value with a tolerance of  $\pm 2^{\circ}\text{C}$ .

The value is detected and indicated in **DR31: transmitter\_temperature**.

If the temperature exceeds  $85^{\circ}\text{C}$ , the error SE\_TRANSMITTER\_TEMPERATURE is generated. If the temperature falls below  $80^{\circ}\text{C}$ , the error is reported as reset.

No further temperature compensation processes are derived from this.

### MODBUS service information

MODBUS service information is information that can only be read. It can be read out of the function module via SIMATIC and MODBUS.

The separate items of MODBUS service information are collected for SIMATIC in data record DR36 and are stored individually for MODBUS under the respective MODBUS address.

The MODBUS service information is information regarding the status of the MODBUS connection and the MODBUS slave.

The MODBUS service data are:

- Device address
- Inter frame space used
- Baudrate Hz
- Number of parity errors
- Number of framing errors
- Number of crc errors
- Number of ok messages received
- Last coil error (Coiladdr)
- Last coil error no
- Last holdreg error (Holdregaddr)
- Last holdReg error no
- Error pending 1
- Error pending 2
- Error pending 3
- Error pending 4
- Error pending 5
- Error pending 6
- Error pending 7
- Error pending 8
- Error pending 9
- Run indicator

### See also

DR31 Service information (R) (Page 228)

## Alarm, error, and system messages

### 12.1 Messages and diagnostics

#### Message types

The messages of the SIFLOW FC070 are divided into two types:

1. Asynchronous messages
2. Synchronous messages

#### Asynchronous messages

Asynchronous messages can be generated spontaneously at any time by an unexpected event. Such events include internal and external hardware faults (status messages) and technology messages which can occur spontaneously during a measurement.

Types of error belonging to the asynchronous messages:

- Sensor errors (SE) (Page 152) indicating faults on the function module, sensor, SENSORPROM or cabling (internal faults)
- Process errors (PE) (Page 152) for faults in the process (external faults)

#### Synchronous messages

The synchronous messages are always the result of a user activity. These include:

- Data errors if a plausibility error has been detected in a data package which was sent to the function module, and receipt of the package has been rejected by the function module.
- Operating errors if the function module in its current operating state cannot execute the sent command.

Types of errors belonging to the synchronous messages:

- Data and operating errors (HE) (Page 156).

---

**Note**

**System status information**

System status information is not a message. The status displays describe the status of the function module during normal operation, and can be monitored or evaluated at any time.

See also: System status information (Page 162).

---

## Message paths

The messages of the SIFLOW FC070 reach the user via different paths. It is necessary when configuring to select the correct message path for passing on and processing.

The messages are processed for two basic purposes:

- For display on an operator panel
- For linking in the control software in order to trigger a certain process response.

The following message paths can be selected:

- Output via the signal outputs of the function block
- Diagnostic interrupts in SIMATIC CPU with evaluation by the OB82
- Process alarms in the SIMATIC CPU with evaluation in the process alarm OBs
- Output of message buffer to SIMATIC PDM

## Detection and processing of messages

There are four different ways of detecting and processing messages:

- **Function block**

All messages of the SIFLOW FC070 can be detected completely using the S7 FB SIFL\_FC (FB95), and processed in the PLC. By means of the output variable FB\_ERR, errors during processing of the respective FB are signaled in addition.

- **Diagnostic interrupts**

The diagnostic interrupts can be used to detect status messages (hardware faults) in the SIMATIC CPU.

- You can display the cause of the error in the module diagnostics in S7 (see "Hardware diagnostics" in the S7 online help).
- You can also read out the diagnostics messages using SFCs in the user program.

- **Process alarms**  
Process alarms can be used to respond extremely flexibly to process messages or certain status information.
  - You can display the cause of the error in the module diagnostics in S7 (see "Hardware diagnostics" in the S7 online help).
  - You can also read out the diagnostics messages using SFCs in the user program.
- **Output to SIMATIC PDM**  
In SIMATIC PDM, you can display an error report and a list of currently present errors in the menu "Error Logbook".

## 12.2 Interrupt behaviour

### Introduction

This section describes the interrupt behavior of the SIFLOW FC070. There are basically two different types of interrupt:

- Diagnostics interrupt
- Process interrupt

For detailed information on the OBs and SFCs mentioned below, refer to the S7 online help.

### Enabling interrupts

The interrupts are preset, but are disabled until programmed accordingly. You program the enabling of interrupts by double clicking the corresponding function module in HW-Config or by marking it and selecting the Basic parameters tab in the Object properties.

### Diagnostics interrupt

When diagnostics interrupts are enabled, incoming error events (initial occurrence) and outgoing error events (error is cleared) are reported by means of an interrupt.

The CPU interrupts execution of the user program and runs the diagnostics interrupt block OB82.

In the user program, you can call SFC 51 or SFC 59 in OB82 to obtain more detailed diagnostics information from the module.

The diagnostics information is consistent until such time as OB82 is exited. When OB82 is exited, the diagnostics interrupt is acknowledged on the module.

#### Reading diagnostics messages

You can read out the first 4 bytes of the diagnostics data record 1 using the variable OB82\_MDL\_DEFECT in the user program. The remaining bytes (or also all of them) can be read using SFC51 "RDSYSST" (reading out an SZL parts list). Do not use the system function "Read data record", if at all possible, since inconsistencies may occur for the interrupt.

You can display the cause of the error in the module diagnostics in S7 (see S7 online help).

### Diagnostics message using the SF LED

The function module indicates faults via its SF LED (group fault LED). The SF LED lights up as soon as a diagnostics message has been triggered by the function module. It is extinguished when all faults have been eliminated.

The SF LED also lights up to indicate external errors (short-circuit at the encoder supply), regardless of the CPU operating state (at POWER ON.)

## Process interrupt

The SIFLOW FC070 can manage 8 process interrupt events. A certain signal can be assigned to each process interrupt event through appropriate parameterization. The signal can be assigned as an incoming HE (operating and data errors), an incoming/outgoing PE / SE (process/sensor errors) or an incoming/outgoing system status bit.

The parameter setting can be changed at any time (in the RUN state using the user program).

Pending process interrupts trigger process interrupt processing in the CPU (OB 40). The CPU interrupts the execution of the user program or the priority classes with low priority.

In the user program of the process interrupt OB (OB 40) you can specify how the programmable controller is to respond to a change in edge. The module acknowledges the process interrupt when the program exits the process interrupt OB.

The module can store 8 interrupts in intermediate memory. If no run levels of a higher priority class are pending processing, the CPU processes the buffered interrupts (of all modules) in the order of their occurrence.

### Process interrupt lost

A "Process interrupt lost" diagnostics interrupt is generated if a successive interrupt occurs before the CPU has processed the previously buffered interrupt.

The CPU does not register any further interrupts unless it has completed processing of the stacked interrupts.

### Interrupt-triggering channels

The channel that triggered the process interrupt is entered in the start information of OB 40 in the OB 40\_POINT\_ADDR variable.

You can find the diagnostics messages with their possible causes and remedies in the table "Sensor and process errors" (Page 152) and in the table "Data and operating errors" (Page 156).

## 12.3 Diagnostics data

### Introduction

Error messages are present in the diagnostics data.



This chapter describes the diagnostics data structure in system data. You must be familiar with this configuration if you want to evaluate the diagnostics data of the SIFLOW FC070 function module in the S7 user program.

---

**Note**

Evaluation of error OBs (I/O access errors, rack error interrupts, hot swapping interrupts, diagnostic interrupts, process alarms) is not carried out in the function block SIFL\_FC (for S7), but must be carried out in the standard interrupt OBs (diagnostic interrupt: OB82, process alarm: OB40).

---

## Requirements

The following prerequisites must be satisfied for generation of parameterizable diagnostics messages:

- The static basic parameter "Interrupt selection" must be set. See section on programming in SIMATIC S7 (Page 57).
- The parameter "Interrupt generation" must be enabled for the associated interrupt. See section on programming in SIMATIC S7 (Page 57).

No parameterizable diagnostic interrupts are triggered if these prerequisites are not fulfilled.

If these prerequisites are fulfilled, every change in the diagnostic state on the function module or sensor results in a diagnostic interrupt.

## Reactions to diagnostic interrupt in S7

Actions initiated by diagnostic interrupt:

- The diagnostics message is entered into the diagnostics of the function module.
- The red SF LED on the function module is lit.
- If you have parameterized "Enable diagnostics interrupt" with S7, the diagnostics data are passed on to the CPU, and a diagnostics interrupt triggered which activates the OB82. The red SF LED is lit. The diagnostics messages can be read in OB82.

Parallel to the OB82, the diagnostics message is automatically displayed in HW-Config without a user program being involved (**PLC > Module status, Diagnostics interrupt and Diagnostic buffer**).

Up to S7 V5.3, the diagnostic interrupt data are displayed as numbers, from V5.4 onwards in plain text.

SE and PE are displayed in plain text in the diagnostic buffer (also when using S7 V5.3), and the HE always as numbers.

You can find the diagnostics messages with their possible causes and remedies in the table "Sensor and process errors" (Page 152) and in the table "Data and operating errors" (Page 156).

### Diagnostics data stored in data records

The diagnostics data of the SIFLOW FC070 function module are 16 bytes long and located in data records 0 and 1:

- Data record 0 contains 4 bytes of diagnostics data describing the current status of the automation system.
- Data record 1 contains the 4 bytes of diagnostics data which are also stored in data record 0, plus further diagnostics data. The remaining 4 bytes (bytes 12 – 15) are not used.

Table 12-1 Overview of diagnostics data

Byte	DR	Diagnostics data
0...3	0 / 1	System diagnostics data
4...7	1	Module-specific diagnostics data
8...11	1	Sensor-specific and process-specific diagnostics data
12...15	1	Reserved

### Reference

An in-depth description of the principle of evaluating the diagnostics data of function modules in the user program and a description of the SFCs that can be used for that purpose can be found in the S7 manuals.

### Read diagnostics data record

You can display the cause of the error in the module diagnostics in S7.

You can read a specific data record from the addressed function module using e.g. the SFC 59 "RD\_REC" (read data record).

#### References

You can find further possibilities for reading out the diagnostics in

- ET 200M distributed I/O system operating instructions (<http://support.automation.siemens.com/WW/view/en/1142798>)
- Programming with S7 V5.x SIMATIC software manual (<http://support.automation.siemens.com/WW/view/en/18652056>)

## 12.4 System diagnostics data bytes 0 to 3

### Introduction

The section below describes the structure and content of the various bytes in the diagnostics data.

---

#### Note

An error is always indicated by a logic "1" at the relevant bit.

---

### Diagnostics data record DR0/DR1: Bytes 0 and 1

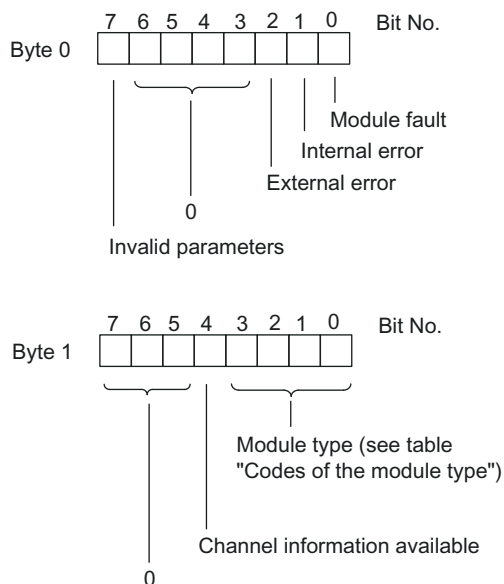

Figure 12-1 Bytes 0 and 1 of diagnostics data

### Module types

The following table lists the function module type IDs (bits 0 to 3 in byte 1).

Table 12-2 Module type IDs

ID	Module type
0101	Analog module
0110	CPU
1000	Function module, e.g. SIFLOW FC070
1100	CP
1111	Digital module

### Diagnostics data record DR0/DR1: Bytes 2 and 3

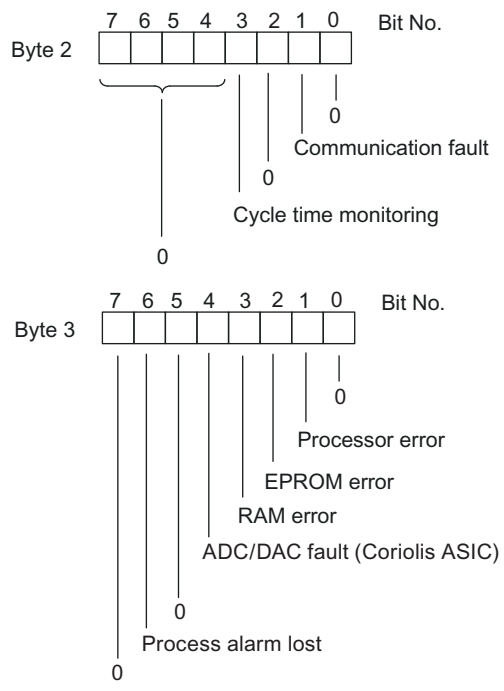

Figure 12-2 Bytes 2 and 3 of diagnostics data

## 12.5 Module-specific diagnostics data bytes 4 to 7

### Introduction

The following figure shows the module-specific diagnostics data for the SIFLOW FC070 function module.

**Diagnostics data record DR1: Bytes 4 to 7**

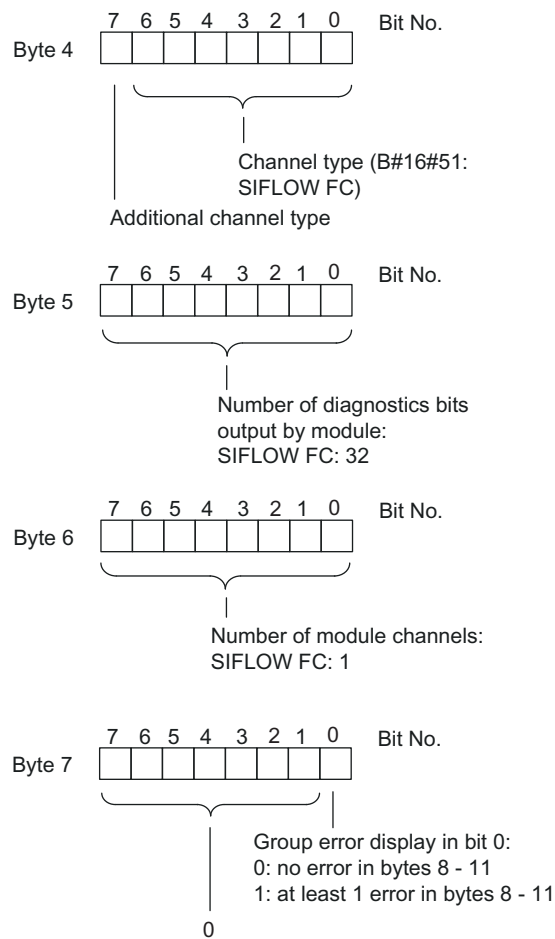

Figure 12-3 Bytes 4 to 7 of diagnostics data

## 12.6 Sensor and process-specific diagnostics data, bytes 8 to 11

### Introduction

Data record 1 contains the sensor-specific and process-specific diagnostics data at bytes 8 to 11. The following figure shows the assignment of the diagnostics bytes for the SIFLOW FC070 function module.

Diagnostics data record DR1: Bytes 8 to 11

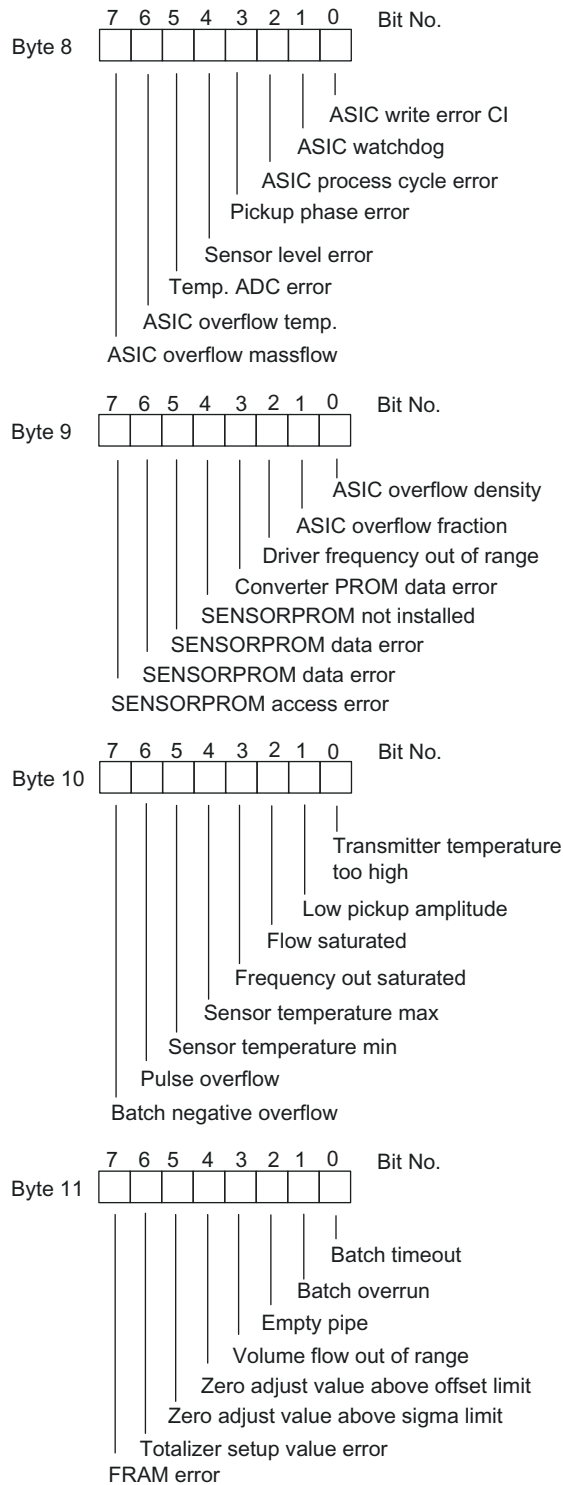

Figure 12-4 Diagnostics data, bytes 8 to 11

---

**Note**

As long as an error is present, the corresponding bit is always set to "1"

---

See also:

- Error messages of the SIFLOW FC070 (Page 151)
- Sensor errors (SE) and process errors (PE) (Page 152)
- Data and operating errors (HE) (Page 156)

## 12.7 Error messages of SIFLOW FC070

### 12.7.1 Error type overview

Table 12-3 SIFLOW FC070 error types

ID value	Type	Type (SIFLOW)
0	-	No error
1	SE	Sensor error (transmitter, sensor, SENSORPROM, cable)
2	PE	Process errors
4	HE	Handling error

- All SE / PE errors are set and reset errors, i.e. coming (C) and going (G) errors. When an SE/PE error occurs, it is coming (C), and the most significant bit is set. When an SE/PE error is no longer active, it is going (G), and the most significant bit is reset. See also "Sensor and process errors (Page 152)"
- HE errors are events (no reset state).

#### SIMATIC error classes

- All sensor errors (SE LED On) are handled as internal errors (and as SF).
- All process errors (PE LED On) are handled as external errors (and as SF).
- All data and operating errors are handled as external errors (no LED On).

**NAMUR VDI 2650 classes**

Table 12-4 NAMUR VDI 2650 classes

Class ID	Class	Meaning	Description
1	F	Error (failure)	Changed configuration, local operation, default value present
2	M	Maintenance request	Short-term maintenance required, medium-term maintenance required
3	C	Check	Device-internal cause of fault, process-dependent cause of fault
4	S	Outside specification	Operation outside the specification, uncertain because of process influences

**12.7.2 Sensor errors (SE) and process errors (PE)**

The following tables list:

- Sensor errors (SE) indicating faults on the function module, sensor, SENSORPROM or cabling (internal faults)
- Process errors (PE) for faults in the process (external faults)

**Note**

All sensor errors (including transmitter errors) switch the red SE LED on and set the corresponding bit ST\_SENSOR\_ERROR in the system status.

All process errors switch the red PE LED on and set the corresponding bit ST\_PROCESS\_ERROR in the system status.

Table 12-5 Sensor errors and process errors (1): Error classes

No.	Diagnostics interrupt	SE / PE	Namur	S7 int./ext.	S7 event ID (HEX)
1	ASIC write error CI	SE	F	i	F5601001
2	ASIC watchdog	SE	F	i	F5601002
3	ASIC process cycle error	SE	F	i	F5601003
4	Reception phase error	SE	F	i	F5601004
5	Sensor level error	SE	F	i	F5601005
6	Temp. ADC error	SE	F	i	F5601006
7	ASIC overflow temperature	SE	F	i	F5601007
8	ASIC mass flow value overflow	SE	F	i	F5601008
9	ASIC overflow density	SE	F	i	F5601009
10	ASIC overflow fraction	SE	F	i	F560100A
11	Driver frequency outside permissible range (driver phase)	SE	F	i	F560100B
12	Converter PROM data error	SE	F	i	F560100C
13	SENSORPROM not installed	SE	M	i/e	FD60100D



No.	Diagnostics interrupt	SE / PE	Namur	S7 int./ext.	S7 event ID (HEX)
14	SENSORPROM data error	SE	M	i/e	FD60100E
15	SENSORPROM ID error	SE	M	i/e	FD60100F
16	SENSORPROM access error	SE	M	i/e	FD601010
17	Transmitter temperature too high	SE	M	l	F5601011
18	Low reception amplitude	SE	F	i	F5601012
19	Flow saturated	PE	C	e	F9601013
20	Outgoing frequency saturated	PE	C	e	F9601014
21	Temp_max	PE	C	e	F9601015
22	Temp_min	PE	C	e	F9601016
23	Pulse overflow	PE	C	e	F9601017
24	Batch processing – negative flow	PE	C	e	F9601018
25	Batch processing - timeout	PE	M	e	F9601019
26	Batch processing - overflow	PE	M	e	F960101A
27	Empty pipe (density < DR3: empty_pipe_limit)	PE	S	e	F960101B
28	Volumetric flow outside permissible range	PE	S	e	F960101C
29	Zero adjustment above deviation limit (Zero_sigma > DR3: zero_sigma_limit)	PE	S	e	F960101D
30	Zero adjustment above sigma limit (Zero_offset_value > DR3: zero_offset_limit)	PE	S	e	F960101E
31	Totalizer setup value error	SE	S	e	F560101F
32	FRAM error	SE	F	i	F5601020
33	DRAM error	SE	F	i	F5601021
34	Startup caused by resetting watchdog	SE	F	i	F5601022
35	Startup caused by program code error	SE	F	i	F5601023
36	Process interrupt lost	SE	F	i	F5601024
37	Parameter error	SE	F	i	F5601025
38	Lifebit monitoring S7 timeout	SE	F	i	F5601026
39	Modbus communication error	SE	M	i/e	FD601027
40	Failure of internal module supply voltage	SE	M	i/e	FD601028

See also Error type overview (Page 151)

Table 12-6 Sensor errors and process errors (2): Error causes and corrective measures

No.	Diagnostics interrupt	Probable cause of error	To correct or avoid error
1	ASIC write error CI	Command interface area cannot be written to	Restart transmitter – replace if error continues to occur
2	ASIC watchdog	Watchdog timeout	Restart transmitter – replace if error continues to occur
3	ASIC process cycle error	Process cycle time longer than 32 768 ms	Restart transmitter – replace if error continues to occur
4	Pickup	Phase difference between channels 1 and 2 exceeds the set limit	Check wiring and sensor
5	Sensor level error	Input level too high – overflow during processing	Check wiring and sensor

12.7 Error messages of SIFLOW FC070

No.	Diagnostics interrupt	Probable cause of error	To correct or avoid error
6	Temperature ADC error	Primary temperature measurements not in the correct sequence or above the limit	Check wiring and sensor
7	ASIC overflow temperature	Overflow in the temperature calculations	Check wiring and sensor
8	ASIC mass flow value overflow	Overflow in the mass flow time calculation	Check wiring and sensor
9	ASIC overflow density	Overflow in the density calculation	Check wiring and sensor
10	ASIC overflow fraction	Overflow in the fraction calculation	Check wiring and sensor
11	Driver frequency outside permissible range (driver phase)	Driver frequency outside permissible range	Check wiring and sensor
12	Converter PROM data error	Data in the converter PROM are not reliable (incorrect checksum). Factory settings will be used instead. Converter PROM is automatically set to factory default values.	Replace transmitter
13	SENSORPROM not installed	No SENSORPROM® installed. Reference data from the internal converter PROM will be used.	Install SENSORPROM. Ignore required SPROM error option.
14	SENSORPROM data error	Data in the SENSORPROM® not reliable (incorrect checksum). Reference data from the internal converter PROM will be used.	Replace SENSORPROM
15	SENSORPROM ID error	SENSORPROM® ID does not match the product ID. Error in the SENSORPROM® data or incorrect SENSORPROM® installed. Reference data from the internal converter PROM will be used.	Replace SENSORPROM
16	SENSORPROM access error	Reading from or writing to the SENSORPROM® not possible. Reference data from the internal converter PROM will be used.	Replace SENSORPROM
17	Transmitter temperature too high	Temperature in the transmitter module too high.	Reduce ambient temperature
18	Low reception amplitude	Pickup amplitude too low.	Check wiring and sensor
19	Flow saturated	Flowrate above the maximum mass flow.	Adjust the setting of the maximum mass flow
20	Outgoing frequency saturated	Frequency above the maximum frequency.	Adjust the frequency setting
21	Temp_max	Temperature beyond the permissible limits.	Adjust the temperature settings
22	Temp_min	Temperature beyond the permissible limits.	Adjust the temperature settings
23	Pulse overflow	Flowrate too high in comparison to the pulse width and quantity per pulse	Adjust pulse settings
24	Batch processing – negative flow	The flow is negative.	Check the installation
25	Batch processing - timeout	Batch processing has exceeded a preset maximum duration.	Check the installation
26	Batch processing - overflow	Batch processing halted but the flow in the pipe not yet ended.	Check the installation
27	Empty pipe (density < DR3: empty_pipe_limit)	Density below the set limit.	Top up the sensor or adjust the limit

No.	Diagnostics interrupt	Probable cause of error	To correct or avoid error
28	Volumetric flow outside permissible range	Overflow in volume flow calculation – can occur if the density is close to zero.	Check the density
29	Zero adjustment above deviation limit (Zero_sigma > DR3: zero_sigma_limit)	Zero adjustment values above the limit.	Check the process for zero flow
30	Zero adjustment above sigma limit (Zero_offset_value > DR3: zero_offset_limit)	Zero sigma values above the limit.	Check the process for zero flow or a fault
31	Totalizer setup value	CRC totalizer value in the F-RAM incorrect	Last totalizer values have been lost. Reset totalizer or set presets
32	FRAM error	F-RAM read/write error	Replace transmitter
33	DRAM error	D-RAM read/write error	Replace transmitter
34	Startup caused by resetting watchdog	A watchdog was reset in the module. This error is set at 3 s in the startup that was caused by resetting the watchdog.	Update firmware. Inform the SIFLOW hotline
35	Startup caused by program code error	Program code checksum error, illegal program execution, or faulty hardware, firmware or incorrect parameters.	Update firmware. Inform the SIFLOW hotline
36	Process interrupt lost	Process interrupt at the S7 P-bus interface lost.	Check S7 CPU and S7 bus. Inform the SIFLOW hotline
37	Parameter error	Checksum of the module data (transmitter information) incorrect.	Inform the SIFLOW hotline
38	Lifebit monitoring S7 timeout	Timeout of SIMATIC CPU lifebit monitoring.	Check S7 CPU and S7 bus
39	Modbus communication error	Communication error with RS232/RS485	Check RS232/RS485 cables and connectors and parameters Check "frame", "parity" and "baud rate"
40	Failure of internal module supply voltage	The supply voltage has dropped below 14.5 V.	Check power supply

### Example: Acknowledging coming (C) and going (G) PE/SE errors

Error "PE Pulse overflow" (PE error number 23) occurs, i.e. the error is coming.

- "ERR\_MSG\_C" = 97 hex = 1001 0111 bin and "ERR\_MSG\_TYPE" = 2.
- This indicates that you have a process error (type = 2) with error number 23 (PE Pulse overflow) that is coming.
- To read the error number you use the number without coming error set bit i.e. "ERR\_MSG\_C" = 0001 0111 bin = 17 hex = 23 decimal.

Error "PE Pulse overflow" is not longer active, i.e. the error is going.

12.7 Error messages of SIFLOW FC070

- "ERR\_MSG\_C" will have 97 hex as long as it is unacknowledged.
- When coming "PE Pulse overflow" error has been acknowledged ("ERR\_MSG\_Q" has been set) the "ERR\_MSG\_C" the error status change from coming to going (from 1001 0111 bin to 0001 0111 bin).
- When going "PE Pulse overflow" error has been acknowledged, "ERR\_MSG\_C" changes from 17 hex (0001 0111 bin) to next unacknowledged error or to 0 if no unacknowledged error resists.

12.7.3 Data and operating errors

The SIMATIC error class of all operating errors is "external", with the error status always being "ON". The Namur class is always "S" (outside the specification).

**Note**

HE errors do not trigger any LEDs

Table 12-7 Data and operating errors

Code	Event	Short description, explanation	S7 event ID (HEX)
1	HE_UNKNOWN_COMMAND	Error code unknown	F9601101
2	HE_UNKNOWN_DATA_RECORD	Data record number unknown	F9601102
3	HE_ZERO_ADJUST_ACTIVE	Zero adjustment in progress; when zero adjustment is in progress no new commands or parameters are accepted.	F9601103
4	HE_BATCH_ACTIVE	Batch in progress; when batch processing is in progress no new start commands or parameters are accepted.	F9601104
5	HE_WRITE_PROTECTION_ACTIVE	Action not allowed if write protection is active	F9601105
6	HE_FACTORY_VALUES_LOADED	Factory settings will be loaded	F9601106
7	HE_CMD_BUSY	New command not permissible because last command is still active.	F9601107
8	HE_CMD_FREEZE_MODE	"Freeze" command only possible if pulse or frequency mode is parameterized at the digital output.	F9601108
9	HE_CMD_FORCE_MODE	"Set" command only possible if pulse or frequency mode is parameterized at the digital output.	F9601109
10	HE_OUTPUT_SIMULATION_ENABLED	No change to the output parameters (DR5 complete and DR11 batch processing parameter) when output simulation is active.	F960110A
11	HE_MODBUS_RESPONSE_TIMEOUT	No MODBUS response is possible within the response time.	F960110B
12	HE_NEW_CODE_LOADED	New application firmware is loaded.	F960110C

Code	Event	Short description, explanation	S7 event ID (HEX)
13	HE_13	Free, not a valid HE.	F960110D
14	HE_14	Free, not a valid HE.	F960110E
15	HE_15	Free, not a valid HE.	F960110F
16	HE_NOT_WRITEABLE_IF_SPROM_MOUNTED	Parameter cannot be written when a SENSORPROM is installed (sensor-specific data).	F9601110
17	HE_DBS_UNKNOWN_DATA_RECORD	Device has received a data record with an unknown number from the S7 CPU or MODBUS.	F9601111
18	HE_18	Free, not a valid HE.	F9601112
19	HE_19	Free, not a valid HE.	F9601113
20	HE_20	Free, not a valid HE.	F9601114
21	HE_FLASHING	Error programming or erasing the FLASH.	F9601115
22	HE_22	Free, not a valid HE.	F9601116
23	HE_FLOW_UNKNOWN_DATA	Not used	F9601117
24	HE_FLOW_UNKNOWN_DR_NUMBER	Device has received a data record with an unknown number.	F9601118
25	HE_25	Free, not a valid HE.	F9601119
26	HE_FLOW_TOTALIZER_HELD	Totalizer has already been held.	F960111A
27	HE_FLOW_TOTALIZER_RUNNING	Totalizer is already running.	F960111B
28	HE_FLOW_BATCH_NOT_PARAMETRIZED	No batch parameterized: batch processing command not permissible	F960111C
29	HE_FLOW_BATCH_IDLE	Batch processing idle: command not permissible (in this case only a command to start the batch is permissible)	F960111D
30	HE_30	Free, not a valid HE.	F960111E
31	HE_FLOW_BATCH_HELD	Batch processing held: command not permissible (in this case only a command to continue or end the batch is permissible)	F960111F
32	HE_FLOW_NOT_READY	Device startup: no command is accepted during the first 40 s after a restart	F9601120
33	HE_FLOW_ERROR	Not used	F9601121
34	HE_FLOW_DATA_CHECK_FAILED	Not used	F9601122
35	HE_FLOW_DATA_EMPTY_PIPE_DETECTION	DR3: empty_pipe_detection_on_off out of range	F9601123
36	HE_FLOW_DATA_EMPTY_PIPE_LIMIT	DR3: empty_pipe_limit out of range	F9601124
37	HE_FLOW_DATA_LOW_FLOW_CUT_OFF	DR3: low_flow_cut_off out of range	F9601125
38	HE_FLOW_DATA_FLOW_DIRECTION	DR3: flow_direction out of range	F9601126
39	HE_FLOW_DATA_NOISE_FILTER	DR3: noise_filter out of range	F9601127
40	HE_FLOW_DATA_ERROR_LEVEL	DR3: error_level out of range	F9601128
41	HE_FLOW_DATA_MASSFLOW_MAX	DR3: massflow_max out of range	F9601129
42	HE_FLOW_DATA_VOLUMEFLOW_MAX	DR3: volumeflow_max out of range	F960112A
43	HE_FLOW_DATA_DENSITY_MAX	DR3: density_max out of range	F960112B
44	HE_FLOW_DATA_SENSOR_TEMP_MAX	DR3: sensor_temperature_max out of range	F960112C
45	HE_FLOW_DATA_FRACTION_A_FLOW_MAX	DR3: fraction_A_flow_max out of range	F960112D

12.7 Error messages of SIFLOW FC070

Code	Event	Short description, explanation	S7 event ID (HEX)
46	HE_FLOW_DATA_FRACTION_B_FLOW_MAX	DR3: fraction_B_flow_max out of range	F960112E
47	HE_FLOW_DATA_PERCENT_FRACTION_A_MAX	DR3: percent_fraction_A_max out of range	F960112F
48	HE_FLOW_DATA_MASSFLOW_MIN	DR3: massflow_min out of range	F9601130
49	HE_FLOW_DATA_VOLUMEFLOW_MIN	DR3: volumeflow_min out of range	F9601131
50	HE_FLOW_DATA_DENSITY_MIN	DR3: density_min out of range	F9601132
51	HE_FLOW_DATA_SENSOR_TEMP_MIN	DR3: sensor_temperature_min out of range	F9601133
52	HE_FLOW_DATA_FRACTION_A_FLOW_MIN	DR3: fraction_A_flow_min out of range	F9601134
53	HE_FLOW_DATA_FRACTION_B_FLOW_MIN	DR3: fraction_B_flow_min out of range	F9601135
54	HE_FLOW_DATA_PERCENT_FRACTION_A_MIN	DR3: percent_fraction_A_min out of range	F9601136
55	HE_FLOW_DATA_ZERO_ADJUST_TIME	DR3: zero_adjust_time out of range	F9601137
56	HE_FLOW_DATA_ZERO_SIGMA_LIMIT	DR3: zero_sigma_limit out of range	F9601138
57	HE_FLOW_DATA_ZERO_OFFSET_LIMIT	DR3: zero_offset_limit out of range	F9601139
58	HE_FLOW_DATA_TOTALIZER_1_SELECTION	DR4: totalizer_1_selection out of range	F960113A
59	HE_FLOW_DATA_TOTALIZER_2_SELECTION	DR4: totalizer_2_selection out of range	F960113B
60	HE_FLOW_DATA_TOTALIZER_1_DIRECTION	DR4: totalizer_1_direction out of range	F960113C
61	HE_FLOW_DATA_TOTALIZER_2_DIRECTION	DR4: totalizer_2_direction out of range	F960113D
62	HE_FLOW_DATA_TOTALIZER_1_FAIL_MODE	DR4: totalizer_1_fail_mode out of range	F960113E
63	HE_FLOW_DATA_TOTALIZER_2_FAIL_MODE	DR4: totalizer_2_fail_mode out of range	F960113F
64	HE_FLOW_DATA_DIG_OUT_SF_REACTION	DR5: digital_output_sf_reaction out of range	F9601140
65	HE_FLOW_DATA_DIG_OUT_FUNCTION	DR5: digital_output_function out of range	F9601141
66	HE_FLOW_DATA_PULSE_VALUE_SELECTION	DR5: pulse_value_selection out of range	F9601142
67	HE_FLOW_DATA_PULSE_OUT_POLARITY	DR5: pulse_output_polarity out of range	F9601143
68	HE_FLOW_DATA_PULSE_DIRECTION	DR5: pulse_direction out of range	F9601144
69	HE_FLOW_DATA_PULSE_WIDTH	DR5: pulse_width out of range	F9601145
70	HE_FLOW_DATA_PULSE_AMOUNT	DR5: pulse_mass_or_volume_amount out of range	F9601146
71	HE_FLOW_DATA_FREQ_VALUE_SELECTION	DR5: frequency_value_selection out of range	F9601147
72	HE_FLOW_DATA_FREQ_DIRECTION	DR5: frequency_direction out of range	F9601148
73	HE_FLOW_DATA_FREQ_MAX	DR5: frequency_max out of range	F9601149
74	HE_FLOW_DATA_FREQ_TIME_CONSTANT	DR5: frequency_time_constant out of range	F960114A

Code	Event	Short description, explanation	S7 event ID (HEX)
75	HE_FLOW_DATA_BATCH_VALUE_SELECTION	DR5: batch_value_selection out of range	F960114B
76	HE_FLOW_DATA_BATCH_COUNTER_DIRECTION	DR5: batch_counter_up_down out of range	F960114C
77	HE_FLOW_DATA_BATCH_OUT_POLARITY	DR5: batch_output_polarity out of range	F960114D
78	HE_FLOW_DATA_BATCH_TIME_ERROR_ON_OFF	DR5: batch_time_error_on_off out of range	F960114E
79	HE_FLOW_DATA_BATCH_OVERRUN_ERROR_ON_OFF	DR5: batch_overrun_on_off out of range	F960114F
80	HE_FLOW_DATA_BATCH_TIME_MAX	DR5: batch_time_max out of range	F9601150
81	HE_FLOW_DATA_BATCH_OVERRUN_QUANTITY	DR5: batch_overrun_error_quantity out of range	F9601151
82	HE_FLOW_DATA_DIG_IN_SF_REACTION	DR6: digital_input_sf_reaction out of range	F9601152
83	HE_FLOW_DATA_INPUT_FILTER_TIME	DR6: digital_input_filter_time out of range	F9601153
84	HE_FLOW_DATA_DIG_IN_INVERSION	DR6: digital_input_inversion out of range	F9601154
85	HE_FLOW_DATA_FREQ_FORCE_OUT_VALUE	DR6: force_frequency_output_value out of range	F9601155
86	HE_FLOW_DATA_DIG_IN_FUNCTION	Setting of the digital input function outside the permissible range DR6: digital_input_function out of range	F9601156
87	HE_FLOW_DATA_SENSOR_SIZE	DR9: sensor_size out of range	F9601157
88	HE_FLOW_DATA_CALIBRATION_FACTOR	DR9: calibration_factor out of range	F9601158
89	HE_FLOW_DATA_CORRECTION_FACTOR	DR9: correction_factor out of range	F9601159
90	HE_FLOW_DATA_SENSOR_TC	DR9: sensor_TC out of range	F960115A
91	HE_FLOW_DATA_DENSITY_PARM_A	DR9: density_parm_A out of range	F960115B
92	HE_FLOW_DATA_DENSITY_PARM_B	DR9: density_parm_B out of range	F960115C
93	HE_FLOW_DATA_DENSITY_TC	DR9: density_TC out of range	F960115D
94	HE_FLOW_DATA_DENSITY_OFFSET	DR9: density_offset out of range	F960115E
95	HE_FLOW_DATA_DENSITY_FACTOR	DR9: density_factor out of range	F960115F
96	HE_FLOW_DATA_FRACTION_OFFSET	DR9: fraction_factor out of range	F9601160
97	HE_FLOW_DATA_FRACTION_FACTOR	DR9: fraction_offset out of range	F9601161
98	HE_FLOW_DATA_SIM_VAL_MASSFLOW	DR10: simulation_value_massflow out of range	F9601162
99	HE_FLOW_DATA_SIM_VAL_VOLUMEFLOW	DR10: simulation_value_volumeflow out of range	F9601163
100	HE_FLOW_DATA_SIM_VAL_DENSITY	DR10: simulation_value_density out of range	F9601164
101	HE_FLOW_DATA_SIM_VAL_SENSOR_TEMP	DR10: simulation_value_sensor_temperature out of range	F9601165
102	HE_FLOW_DATA_SIM_VAL_PERCENT_FRACTION_A	DR10: simulation_value_percent_fraction_a out of range	F9601166
103	HE_FLOW_DATA_SIM_VAL_OUTPUT_1	DR10: simulation_value_output_1 out of range	F9601167
104	HE_FLOW_DATA_SIM_VAL_OUTPUT_1_FREQ	DR10: simulation_value_output_1_frequency out of range	F9601168
105	HE_FLOW_DATA_SIM_VAL_OUTPUT_2	DR10: simulation_value_output_2 out of range	F9601169

12.7 Error messages of SIFLOW FC070

Code	Event	Short description, explanation	S7 event ID (HEX)
106	HE_FLOW_DATA_SIM_VAL_OUTPUT_2_FREQ_REQ	DR10: simulation_value_output_2_frequency out of range	F960116A
107	HE_FLOW_DATA_SIM_VAL_INPUT	DR10: simulation_value_input out of range	F960116B
108	HE_FLOW_DATA_SIM_VAL_ERROR_NO	DR10: simulation_value_error_no out of range	F960116C
109	HE_FLOW_DATA_BATCH_QUANTITY	DR11: batch_compensation out of range	F960116D
110	HE_FLOW_DATA_BATCH_COMPENSATION	DR11: batch_quantity out of range	F960116E
111	HE_FLOW_DATA_BATCH_LEAD_CONSTANT	DR11: batch_lead_constant out of range	F960116F
112	HE_FLOW_DATA_BATCH_TWO_STAGE_LEVEL	DR11: batch_two_stage_level out of range	F9601170
113	HE_FLOW_DATA_TOTALIZER_1_PRESET_VAL	DR11: totalizer_1_preset_value out of range	F9601171
114	HE_FLOW_DATA_TOTALIZER_2_PRESET_VAL	DR11: totalizer_2_preset_value out of range	F9601172
115	HE_FLOW_DATA_ZERO_OFFSET_PRESET_VAL	DR11: zero_offset_preset_value out of range	F9601173
116	HE_FLOW_DATA_LIMIT_1_SELECTION	DR12: limit1_selection out of range	F9601174
117	HE_FLOW_DATA_LIMIT_1_DIRECTION	DR12: limit1_direction out of range	F9601175
118	HE_FLOW_DATA_LIMIT_1_SETPOINT	DR12: limit1_setpoint out of range	F9601176
119	HE_FLOW_DATA_LIMIT_1_HYSTERESIS	DR12: limit1_hysteresis out of range	F9601177
120	HE_FLOW_DATA_LIMIT_2_SELECTION	DR12: limit2_selection out of range	F9601178
121	HE_FLOW_DATA_LIMIT_2_DIRECTION	DR12: limit2_direction out of range	F9601179
122	HE_FLOW_DATA_LIMIT_2_SETPOINT	DR12: limit2_setpoint out of range	F960117A
123	HE_FLOW_DATA_LIMIT_2_HYSTERESIS	DR12: limit2_hysteresis out of range	F960117B
124	HE_FLOW_DATA_LIMIT_3_SELECTION	DR12: limit3_selection out of range	F960117C
125	HE_FLOW_DATA_LIMIT_3_DIRECTION	DR12: limit3_direction out of range	F960117D
126	HE_FLOW_DATA_LIMIT_3_SETPOINT	DR12: limit3_setpoint out of range	F960117E
127	HE_FLOW_DATA_LIMIT_3_HYSTERESIS	DR12: limit3_hysteresis out of range	F960117F
128	HE_FLOW_DATA_LIMIT_4_SELECTION	DR12: limit4_selection out of range	F9601180
129	HE_FLOW_DATA_LIMIT_4_DIRECTION	DR12: limit4_direction out of range	F9601181
130	HE_FLOW_DATA_LIMIT_4_SETPOINT	DR12: limit4_setpoint out of range	F9601182
131	HE_FLOW_DATA_LIMIT_4_HYSTERESIS	DR12: limit4_hysteresis out of range	F9601183
132	HE_FLOW_DEVICE_ADDRESS	DR0: device_address	F9601184
133	HE_133	Free, not a valid HE.	F9601185
134	HE_134	Free, not a valid HE.	F9601186
135	HE_FLOW_DATA_STANDALONE	DR7: standalone out of range	F9601187
136	HE_FLOW_DATA_OUTPUT_VAR1_ASS	DR7: s7_peri_output_var_1_assignment out of range	F9601188
137	HE_FLOW_DATA_OUTPUT_VAR2_ASS	DR7: s7_peri_output_var_2_assignment out of range	F9601189
138	HE_FLOW_DATA_PRAL0_ASSIGNMENT	DR7: s7_pral0_assignment invalid	F960118A
139	HE_FLOW_DATA_PRAL1_ASSIGNMENT	DR7: s7_pral1_assignment invalid	F960118B
140	HE_FLOW_DATA_PRAL2_ASSIGNMENT	DR7: s7_pral2_assignment invalid	F960118C



Code	Event	Short description, explanation	S7 event ID (HEX)
141	HE_FLOW_DATA_PRAL3_ASSIGNMENT	DR7: s7_pral3_assignment invalid	F960118D
142	HE_FLOW_DATA_PRAL4_ASSIGNMENT	DR7: s7_pral4_assignment invalid	F960118E
143	HE_FLOW_DATA_PRAL5_ASSIGNMENT	DR7: s7_pral5_assignment invalid	F960118F
144	HE_FLOW_DATA_PRAL6_ASSIGNMENT	DR7: s7_pral6_assignment invalid	F9601190
145	HE_FLOW_DATA_PRAL7_ASSIGNMENT	DR7: s7_pral7_assignment invalid	F9601191
146	HE_FLOW_DATA_MODBUS_BAUDRATE	DR7: modbus_baudrate out of range	F9601192
147	HE_FLOW_DATA_MODBUS_PAR_FRAMING	DR7: modbus_parity_framing out of range	F9601193
148	HE_FLOW_DATA_MODBUS_RESP_TIMEOUT	DR7: modbus_response_timeout out of range	F9601194
149	HE_FLOW_DATA_MODBUS_RESP_DELAY	DR7: modbus_response_delay out of range	F9601195
150	HE_FLOW_DATA_MODBUS_INTER_FRAME_SPACE	DR7: modbus_inter_frame_space out of range	F9601196
151	HE_FLOW_DATA_TIME	Setting of date or time out of allowed range. Correct your date and time values §	Year:
152	HE_FLOW_DATA_CT_PV1_ID	DR39: process_value_1_ID out of range	F9601198
153	HE_FLOW_DATA_CT_PV2_ID	DR39: process_value_2_ID out of range	F9601199
...249	Reserved		
250	HE_PERI_700_VARS	Error with transfer S7 control signals bytes 2 to 15 when via command 700	F96011FA
251	HE_PERI_701_IN_VAR_ADDR	Error with transfer S7 control signals bytes 2, 3 when via command 701	F96011FB
252	HE_PERI_701_IN_VAR_VALUE	Error with transfer S7 control signals bytes 4, 5 when via command 701	F96011FC
253	HE_PERI_702_DIGITAL_OUTPUT	Error with transfer S7 control signals bytes 8, 9 when via command 702	F96011FD
254	HE_PERI_703_OUT_VAR1_ADDR	Error with transfer S7 control signals bytes 12, 13 when via command 703	F96011FE
255	HE_PERI_704_OUT_VAR2_ADDR	Error with transfer S7 control signals bytes 14, 15 when via command 704	F96011FF

#### 12.7.4 Error information in the output parameter ERR\_MSG\_C or CMD\_ERR\_C

The error code number (CMD\_ERR\_C) is the output for commands which do not execute (finished with error). The specified number is broken down in the "Data and operating errors" (Page 156) table. The value remains in the output until the next command is triggered.

Sensor error (SE) codes 1–40, process error (PE) codes 1-40 and data and operating error codes are described in tables above. Error codes 250-255 are common error codes for all error types and are described in following table:

12.8 System status information

Table 12-8 Error information of function block SIFL\_FC

Error code	Description
250	Group error: At least one error is present in the values sent over the I/O interface. None of the values have been imported by the function module (Error response to command 700)
251	Address error in VAR_ADR, address has not been imported by the function module (Error response to command 701)
252	Output value VAR_VAL is invalid, and has not been imported by the function module (Error response to command 701)
253	Output value of DIG_OUT is invalid, and has not been imported by the function module (Error response to command 702)
254	Address error in VAR1_ADR, address has not been imported by the function module (Error response to command 703)
255	Address error in VAR2_ADR, address has not been imported by the function module (Error response to command 704)

## 12.8 System status information

System status information is not a message. It describes the status of the function module during normal operation, and can be monitored or evaluated at any time.

The following table describes system status (SC\_STATUS) and how the status bytes are mapped to a double variable (MD52 in this example) in S7.

### Example

Status information is read to MD52 showing the following value: 01001020Hex or 00000001-00000000-00010000-00100000 binary. This indicates the following device status:

- ST\_BATCHING (M55.0)
- ST\_SIMULATION\_ACTIVE (M53.4)
- ST\_SENSOR\_ERROR (M52.5)

Table 12-9 System status information

Bit	MD52 Example	Name	Explanation and value range
0	M55.0	ST_BATCHING	1 = Batch running
1	M55.1	ST_BATCH_HELD	1 = Batch held (pause)
2	M55.2	ST_BATCH_STOPPED	1 = Batch stopped (last batch not completed)
3	M55.3	ST_BATCH_TWO_STAGE_REACHED	1 = Two-stage value reached
4	M55.4	Reserved	-
5	M55.5	Reserved	-
6	M55.6	ST_TOTALIZER1_HELD	1 = Totalizer 1 held
7	M55.7	ST_TOTALIZER2_HELD	1 = Totalizer 2 held

Bit	MD52 Example	Name	Explanation and value range	
8	M54.0	MB54	ST_ZERO_ADJUST_OFFSET_LIMIT_EXCEEDED	1 = Value above zero adjustment offset limit
9	M54.1		ST_ZERO_ADJUST_IN_PROGRESS	1 = Zero adjustment in progress
10	M54.2		ST_LIMIT_1	1 = Value above or below setpoint 1 according to DR12: limit1_direction
11	M54.3		ST_LIMIT_2	1 = Value above or below setpoint 2 according to DR12: limit2_direction
12	M54.4		ST_LIMIT_3	1 = Value above or below setpoint 3 according to DR12: limit3_direction
13	M54.5		ST_LIMIT_4	1 = Value above or below setpoint 4 according to DR12: limit4_direction
14	M54.6		Reserved	-
15	M54.7		Reserved	-
16	M53.0	MB53	ST_CT_MODE	1 = CT mode active
17	M53.1		ST_DIGITAL_INPUT_STATE	1 = high; 0 = low
18	M53.2		ST_FACTORY_VALUES_LOADED	1 = Factory values are loaded in full (bit is reset if the first value is changed)
19	M53.3		ST_WRITE_PROTECTION_ACTIVE	1 = Write protection active (downloading of firmware not possible)
20	M53.4		ST_SIMULATION_ACTIVE	1 = At least one process value is simulated (the simulated values are available in DR10)
21	M53.5		Reserved	-
22	M53.6		ST_OUTPUT_VALUE_FORCED	OUTPUT 1 is set
23	M53.7		ST_OUTPUT_VALUE_FROZEN	OUTPUT 1 is frozen
24	M52.0	MB52	Reserved	-
25	M52.1		Reserved	-
26	M52.2		ST_DATE_AND_TIME_NOT_SYNC	1 = Date and time not set on startup or not synchronized within 180 seconds via DR8
27	M52.3		ST_PARAMETER_CHANGED_BY_S7	Set if SIMATIC parameter has changed (reset after the command CMD_PARA_CHANGE_ACK from MODBUS)
28	M52.4		ST_PARAMETER_CHANGED_BY_MODBUS	Set if MODBUS parameter has changed (reset after the command CMD_PARA_CHANGE_ACK from S7)
29	M52.5		ST_SENSOR_ERROR	Sensor error (SE LED)
30	M52.6		ST_PROCESS_ERROR	Process error (PE LED)
31	M52.7		ST_SF	1 = Module faulty (SF = group fault/sum bit for sensor and process errors); SF LED

## 12.9 Slave diagnostics

The IM 153-x provides slave diagnostics in accordance with the standard IEC 61784-1:2002 Ed1 CP 3/1.

---

### Note

The structure of the diagnostics data in case of slave diagnostics is described in detail in the operating instructions for the ET 200M distributed I/O system. The following only provides general information.

---

### Information on "enhanced diagnostics" of the ET 200M

To be able to use the channel-specific diagnostics, you must enable the diagnostics interrupts for each I/O module of the configuration.

When configuring the IM 153-x you can enable or block the diagnostics, process and hot swapping interrupts, and you can do this independently of the enabling of "enhanced diagnostics".

Via the DP V1 parameter (as of GSD Revision 3), you can block or enable the individual blocks of the enhanced diagnostics. Blocked diagnostics will be removed from the diagnostics frame.

In order to delete channel errors from the diagnostics frame, you must switch off the "enhanced diagnostics" in the configuration.

<b>CAUTION</b>
----------------

If you have enabled "enhanced diagnostics" during the configuration and a diagnostics interrupt is triggered for a module only while the ET 200M is running, a channel error will not be immediately entered in the diagnostics frame. A channel error will only be entered into the diagnostics frame following triggering of the first diagnostics interrupt of the module generated following enabling.
--

---

### Note

Observe the differences in the diagnostics frame depending on the version of the IM 153-x and on the release version. With IM 153-2Bx00 and IM 153-2Bx1 the enhanced diagnostics is available as default in DP V0 / DP V1 mode. It can be deselected (switched off) in blocks during the configuration.

---

### Interrupts

The interrupt part of the slave diagnostics provides information on the interrupt type and cause that resulted in triggering of the slave diagnostics.

The ET 200M supports the following interrupts:

- Diagnostics interrupt
- Process interrupt
- Hot swapping interrupt

These interrupts can be evaluated using an S7 / M7 DP master or DP V1 master. In the event of an interrupt, interrupt OBs are executed automatically in the master CPU.

The interrupt part encompasses a maximum of 29 bytes. A maximum of 1 interrupt can be reported for each slave diagnostics.

### Position in the diagnostics frame

The position of the interrupt part in the slave diagnostics depends on the configuration of the diagnostics frame and on the number of channel-specific diagnostics. The interrupt part is always the last part in the diagnostics frame.

- The bytes x to x+3 inform you of the interrupt type.
- The bytes x+4 to x+7 inform you of the interrupt cause. They correspond to the diagnostics data record 0 in S7.
- Bytes x+4 to x+7 and x+8 to x+19 correspond to diagnostics data record 1 in S7.

### Interrupts with a different DP master

If the ET 200M is being operated with a different DP master, these interrupts will be mapped as device-related diagnostics of the ET 200M. You must continue to process the respective diagnostics events in the user program of the DP master.

### References

The structure of the diagnostics data for slave diagnostics is described in detail in ET 200M distributed I/O system operating instructions (<http://support.automation.siemens.com/WW/view/en/1142798>)



## Service and maintenance

Under ideal conditions the flowmeter will operate continuously with no manual adjustment or intervention required.

### 13.1 Maintenance

The device is maintenance-free, however, a periodic inspection according to pertinent directives and regulations must be carried out.

An inspection can include check of:

- Ambient conditions
- Seal integrity of the process connections, cable entries, and cover screws
- Reliability of power supply, lightning protection, and grounds

### 13.2 Unit repair

<b>CAUTION</b>
Repair and service must be carried out by Siemens authorized personnel only.

---

**Note**

Siemens defines flow sensors as non-repairable products.

---

### 13.3 Technical support

If you have any technical questions about the device described in these Operating Instructions and do not find the right answers, you can contact Customer Support:

- Via the Internet using the **Support Request**:  
Support request (<http://www.siemens.com/automation/support-request>)
- Via Phone:
  - Europe: +49 (0)911 895 7222
  - America: +1 423 262 5710
  - Asia-Pacific: +86 10 6475 7575

Further information about our technical support is available on the Internet at  
Technical support (<http://support.automation.siemens.com/WW/view/en/16604318>)

### Service & Support on the Internet

In addition to our documentation, we offer a comprehensive knowledge base online on the Internet at:

Service and support (<http://www.siemens.com/automation/service&support>)

There you will find:

- The latest product information, FAQs, downloads, tips and tricks.
- Our newsletter, providing you with the latest information about your products.
- Our bulletin board, where users and specialists share their knowledge worldwide.
- You can find your local contact partner for Industry Automation and Drives Technologies in our partner database.
- Information about field service, repairs, spare parts and lots more under "Services."

### Additional Support

Please contact your local Siemens representative and offices if you have additional questions about the device

Find your contact partner at:

Local contact person (<http://www.automation.siemens.com/partner>)

## 13.4 Return procedures

Enclose the delivery note, the cover note for return delivery and the declaration of decontamination form on the outside of the package in a well-fastened clear document pouch.



## Required forms

- **Delivery Note**
- **Cover Note for Return Delivery** with the following information  
Cover note (<http://support.automation.siemens.com/WW/view/en/16604370>)
  - product (ordering number)
  - number of devices or spare parts returned
  - reason for the return
- **Declaration of Decontamination**  
Declaration of Decontamination ([http://pia.khe.siemens.com/efiles/feldg/files/Service/declaration\\_of\\_decontamination\\_en.pdf](http://pia.khe.siemens.com/efiles/feldg/files/Service/declaration_of_decontamination_en.pdf))  
*With this declaration you certify that the returned products/spare parts have been carefully cleaned and are free from any residues.*  
If the device has been operated together with toxic, caustic, flammable or water-damaging products, clean the device before return by rinsing or neutralizing. Ensure that all cavities are free from dangerous substances. Then, double-check the device to ensure the cleaning is completed.  
We shall not service a device or spare part unless the declaration of decontamination confirms proper decontamination of the device or spare part. Shipments without a declaration of decontamination shall be cleaned professionally at your expense before further proceeding.

You can find the forms on the Internet and on the CD delivered with the device.



## Diagnosing and troubleshooting

### 14.1 LED status display

SIFLOW FC070 has 12 LEDs which display the status of the function module.

---

#### Note

When the module has been powered up and initialized only "RUN" should show constant light, and "FLO" should blink if the meter is measuring flow.

---

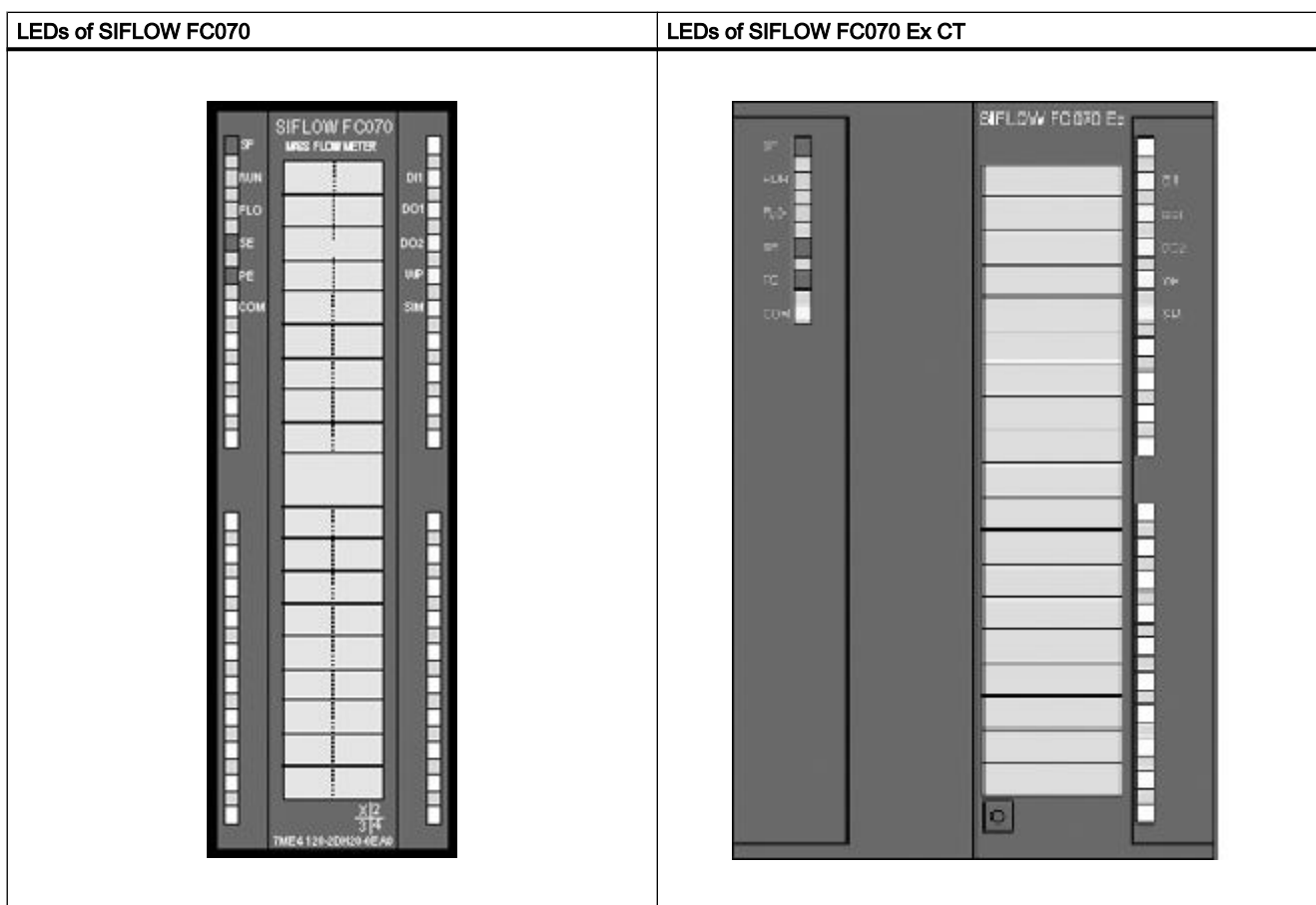

Table 14-1 Meaning of LEDs in normal mode

Item	Color	Designation	Meaning
LED 1	red	SF	Group errors
LED 2	green	RUN	Power / RUN (start-up: flashes, operation: on)
LED 3	green	FLO	Flow indicator, indicates the approximate mass flowrate: Slow flashing (2 Hz) = shutdown ... 33% Medium-speed flashing (5 Hz) = 33 ... 66% Rapid flashing (10 Hz) = 66 ... 100%
LED 4	red	SE	Sensor error
LED 5	red	PE	Process error
LED 6	yellow	COM	MODBUS communication active i.e. the addressed module sends/receives
LED 7	yellow	DI1	Digital input
LED 8	yellow	DO1	Digital output 1
LED 9	yellow	DO2	Digital output 2
LED 10	yellow	WP	WP (Write protection activated) or in CT mode (custody transfer)
LED 11	yellow	SIM	Simulation mode
LED 12	yellow		(only used for displaying start-up LED patterns and fatal error LED patterns)

## 14.2 Diagnostics with LED

The LEDs provide you with initial important diagnostics information.

Table 14-2 LEDs in the various operating phases

Operating phase	LEDs												Remarks
1	2	3	4	5	6	7	8	9	10	11	12		
SF (rd)	RUN (gn)	FLO (gn)	SE (rd)	PE (rd)	CO M (ye)	DI1 (ye)	DO1 (ye)	DO2 (ye)	WP (ye)	SIM (ye)	--		
HW reset	X	X	X	X	X	X	X	X	X	X	X	X	Approx. 200 ms
Startup of boot system	X	X	X	X	X	X	X	X	X	X	X	X	Approx. 500 ms
Startup of application	BS	O	O	O	O	O	BS	BS	BS	BS	BS	BS	Approx. 100 ms or 1.6 s (with power supply on)
Startup of sensor	O/X	BS	O	O/X	O/X	O/X	O/X	O/X	O/X	O/X	O/X	O	Approx. 40 s LEDs 1, 4 ... 11 depending on current state
Normal mode	O/X	X	O/X	O/X	O/X	O/X	O/X	O/X	O/X	O/X	O/X	O	LEDs 1,3...11 depending on current state

Operating phase	LEDs												Remarks
Serious fault	BF	O	O	BF	BF	O	O/BF	O/BF	O/BF	O/BF	O/BF	O/BF	LEDs 7...12 depending on serious fault (see table below)
Load boot system	O	BF	O/X	O	O	O/X	X	X	X	X	X	X	FLO LED = Flash programming

**Note**

LED 12 is only used for displaying start-up LED patterns and fatal error LED patterns

Legend:

O = OFF	BS = slow flashing (2 Hz)	(rd) = red LED
X = ON	BM = medium-fast flashing (5 Hz)	(gn) = green LED
O/X = OFF or ON	BF = fast flashing (10 Hz)	(ye) = yellow LED

Table 14-3 LED check in case of a fatal system error (flashes for approx. 4 s)

1	2	3	4	5	6	7	8	9	10	11	12	Remarks
SF (rd)	RUN (gn)	FLO (gn)	SE (rd)	PE (rd)	COM (ye)	DI1 (ye)	DO 1 (ye)	DO 2 (ye)	WP (ye)	SIM (ye)	---	
BF	O	O	BF	BF	O	O	O	O	O	BF	BF	New code is loaded
BF	O	O	BF	BF	O	BF	BF	BF	O	BF	BF	Errors in function module data (CRC)
BF	O	O	BF	BF	O	O	O	O	BF	BF	BF	Error in operating system
BF	O	O	BF	BF	O	BF	O	O	BF	BF	BF	Error in application code
BF	O	O	BF	BF	O	O	BF	O	BF	BF	BF	Error in boot system code
BF	O	O	BF	BF	O	BF	BF	O	BF	BF	BF	Error in Coriolis ASIC cycle
BF	O	O	BF	BF	O	O	O	BF	BF	BF	BF	Error in FLASH programming
BF	O	O	BF	BF	O	BF	O	BF	BF	BF	BF	FRAM error
BF	O	O	BF	BF	O	O	BF	BF	BF	BF	BF	DRAM error
BF	O	O	BF	BF	O	BF	BF	BF	BF	BF	BF	Powerfail active

Legend:

O = OFF	BS = slow flashing (2 Hz)	(rd) = red LED
X = ON	BM = medium-fast flashing (5 Hz)	(gn) = green LED
O/X = OFF or ON	BF = fast flashing (10 Hz)	(ye) = yellow LED

You can find the diagnostics messages with their possible causes and remedies in the table "Sensor and process errors" (Page 152) and in the table "Data and operating errors" (Page 156).

### 14.3 Diagnosing with PDM

SIMATIC PDM is a suitable tool for diagnosing the device. You can use SIMATIC PDM to read all parameters available in SIFLOW FC070 to a table for analyzing offline, view online/actual process values and online/actual diagnostic information.

#### Requirements

The following procedure must be completed before diagnosing:

- Installation of PDM and SIFLOW FC070 PDM driver (See also Software installation (Page 49))
- Connection of Modbus interface. (See also Connecting (Page 35))

#### Diagnosing with PDM

Online process values are available under menu "View->display".

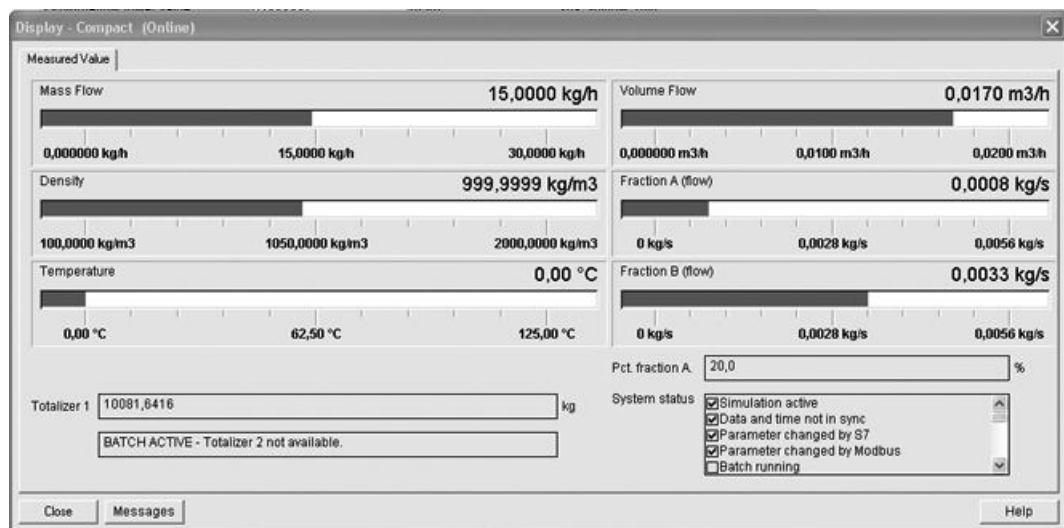

Figure 14-1 PDM online view

Online diagnostic information is available under menu "View->Device Status" and "View->Log book".

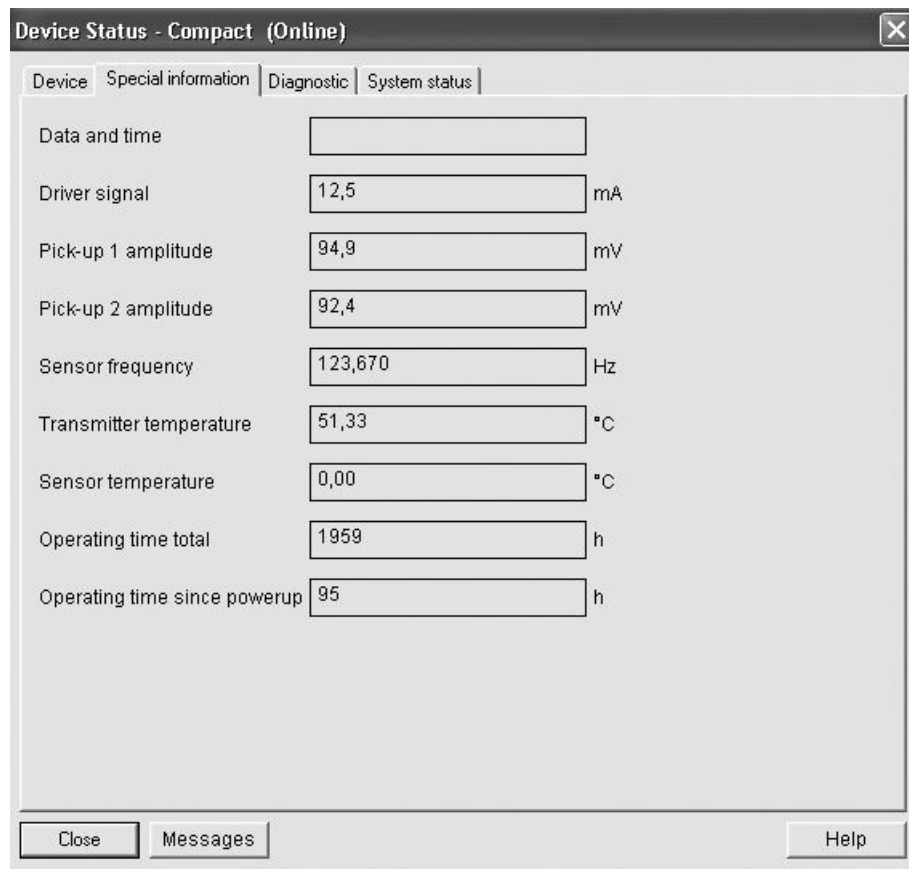

Figure 14-2 PDM online device status

## 14.4 Troubleshooting sensor and unstable measurement values

### 14.4.1 General information

Incorrect and unstable measurements, especially at low flows, are typically a result of an unstable zero point due to:

- Incorrect installation
- Air bubbles in the liquid
- Vibrations/Cross talk
- Solid particles in the liquid

In the following a 4-steps guide to troubleshooting is provided:

- |        |                                    |
|--------|------------------------------------|
| Step 1 | Preliminary application inspection |
| Step 2 | Zero point adjustment              |

Step 3 Measurement error calculation

Step 4 Application improvement

The guide will enable you to trace the reason for incorrect measurements and to improve the application.

### 14.4.2 Step 1: Inspecting the application

The first step in the troubleshooting procedure is to check for some easily resolved problems.

Check that:

- Sensor and SENSORPROM unit correspond (serial numbers)
- The sensor is properly installed.
- The sensor is located in a vibration-free position. Vibrations can disturb the sensor and therefore cause measurement error.
- The sensor is filled with liquid and liquid only. Air or gas bubbles in the liquid cause instability and can result in measurement errors.

---

#### Note

The liquid must be homogeneous in order to measure with high accuracy. If the liquid contains solid particles of greater density than the liquid, then these solids can precipitate, especially at low flow rates, which will cause instability in the sensor and lead to measurement errors.

---

### Resolving step 1 problems

1. Make sure that the serial numbers on the sensor and the SENSORPROM® unit are identical.
2. Make sure that the sensor is installed as described in the installation chapter of the sensor manual.
3. Flush the pipe systems and the sensor for several minutes at maximum flow rate to remove any air bubbles which may be present.

### 14.4.3 Step 2: Performing a zero point adjustment

The second step in the troubleshooting procedure is to zero point adjust the device. For further information on zero point adjustment, see the commissioning chapter.

### See also

Commissioning with SIMATIC PDM (Page 77)

Commissioning with SIMATIC S7 (Page 81)



### 14.4.4 Step 3: Calculating the measurement error

#### Calculating the measurement error

The result of the zero point adjustment will show you whether the zero point was set under good and stable conditions. The lower the value of ZERO SIGMA, the lower the measuring error.

For a well-installed flow meter, the ZERO SIGMA value is approximately the same order of magnitude as the specified zero point error for the sensor size. The specified zero point errors of MASS 2100 and MC2 are indicated below

Table 14-4 MASS 2100 / FC300 / FCS200 zero point error

Sensor size	Zero point error/ZERO SIGMA value.
Di 1.5	0.001 kg/h
Di3	0.010 kg/h
DN4	0.010 kg/h
Di6	0.050 kg/h
Di15	0.2 kg/h
Di25	1.5 kg/h
Di40	6 kg/h
DN10	0.25 kg/h
DN15	1.2 kg/h
DN25	3 kg/h

Table 14-5 MC2 zero point error

Sensor size	Zero point error/ZERO SIGMA value.
DN 20	0.6 kg/h
DN 25	0.96 kg/h
DN 40	2.85 kg/h
DN50	5.5 kg/h
DN65	11.4 kg/h
DN80	14.8 kg/h
DN100	25 kg/h
DN150	66 kg/h

Given the ZERO SIGMA value reading, it is possible to calculate the error which can be expected for different flow rates, without performing time-consuming measurements. So using this formula, one can assess if the application can be used as-is, or whether to use more time improving the installation.

$$E = Z \times 100\% / Q_m$$

E = measurement error in % of flow rate  
 Z = Zero Sigma value in kg/h  
 Q<sub>m</sub> = current flow rate in (kg/h)

### Example 1: Low flow rate application

- Di 15 sensor. The sensor is specified to max. 5600 kg/h
- Zero point error/ZERO SIGMA value is specified as 0.2 kg/h
- Flow: Min. 10 kg/h - Max. 100 kg/h

After the zero point adjustment, the ZERO SIGMA value 'Z' is read as 1 kg/h, i.e. 5 times greater than that specified for the sensor.

The error for a flow rate of 10 kg/h is estimated as:

- $E = 1 \text{ kg/h} \times 100\% / 10 \text{ kg/h} = 10\%$ .

For a flow rate of 100 kg/h the error is estimated as:

- $E = 1 \text{ kg/h} \times 100\% / 100 \text{ kg/h} = 1\%$

For this application it is necessary to investigate more closely what the cause of the relatively high ZERO SIGMA value is, in order to establish what needs to be done to improve the measurement accuracy.

### Example 2 : High flow rate application

- Di 15 sensor. The sensor flow rate is specified as max. 5600 kg/h
- The zero point error/ZERO SIGMA value is specified as 0.2 kg/h
- Flow rate: Min. 1000 kg/h - Max. 3000 kg/h

After the zero point adjustment, the ZERO SIGMA value 'Z' is read as 1 kg/h, i.e. 5 times greater value than that specified for the sensor!

The error at a flow rate of 1000 kg/h is estimated as:

- $E = 1 \text{ kg/h} \times 100\% / 1000 \text{ kg/h} = 0.1\%$

At a flow rate of 3000 kg/h the error is estimated to be:

- $E = 1 \text{ kg/h} \times 100\% / 3000 \text{ kg/h} = 0.03\%$   
Plus the linearity error of 0.1 %

As can be seen, in this case it is not so important that the zero point, i.e. ZERO SIGMA Value, is 1 kg/h. The error due to the zero point is only 0.1 % for a flow rate of 1000 kg/h, and even less for a higher flow rate.

So for this installation with the given flow rate and zero point error (ZERO SIGMA value), you should typically choose not to spend more time finding ways to improve the application.

## 14.4.5 Step 4: Improving the application

It is not always worth while investing time and money in improving the installation and thus the measurement accuracy. However, it should always be checked where the zero point error (ZERO SIGMA value) originates from.

In the following it is described how to find the causes of a high ZERO SIGMA value and how to improve the installation.

### Setting "low flow cut-off"

In order to see if the zero point becomes more stable when making changes / adjustments, the "low flow cut-off" must be set to 0.0%.

This is done from the transmitter:

MASS 6000	SIFLOW FC070
Choose menu entry "Basic settings" → Low flow cut-off	Choose PDM table Choose input

When "low flow cut-off" has been set, it is possible to see the instability directly from the mass flow in kg/h in the transmitter display or the online window "View → Display".

This information can be used to troubleshoot. For example, tightening the brackets which hold the sensor, or turning off the pump to check if vibrations from the pump are disturbing the sensor, etc.

### Incorrect installation of the sensor

- Has the sensor been correctly installed, i.e. fastened to the floor/wall or frame with good mounting brackets as shown in the instructions?

Especially for low flow rates, i.e. flow rates less than 10% of the maximum capacity of the flowmeter, it is important that the sensor is correctly and stably installed.

If the sensor is not correctly fixed in place, the zero point of the sensor will change, leading to measuring errors.

Try to tighten up the sensor brackets to see whether the flow instability is reduced.

### Vibrations and cross talk

Vibrations in the pipe system are normally generated by pumps.

Typically, cross talk is generated by two sensors positioned in close proximity in the same pipe, or installed upon the same rail or frame.

Vibrations/cross talk have a greater or lesser effect upon the zero point stability and therefore also the measurement accuracy.

1. Check whether there are vibrations.  
Turn off the pump and check whether the zero point stability improves, i.e. if the flow rate fluctuation in kg/h is reduced.  
If the sensor is disturbed by vibration from the pump, the installation should be improved or the pump should be exchanged, e.g. to another type.
2. Check for cross talk.  
Turn off the power to the other flowmeter(s) and wait approximately 2 minutes, so the vibrating tubes in the sensor have stopped vibrating. Then check if the zero point stability has improved, i.e. that the fluctuation in kg/h has been reduced. If this is the case, the sensors disturb one another and the installation should be improved.

### Air in the liquid

When air is present in the liquid, the zero point becomes unstable, which leads to a poor measurement accuracy.

Checking for air:

- Check the Driver Current

MASS 6000	SIFLOW FC070
Menu entry Service mode → Special information	Online menu: View → Device status

- Check if the "Driver current" varies more than  $\pm 1$  mA. If this is the case, it is usually due to the presence of air or gas bubbles in the liquid.
- Increase the pressure in the sensor, creating a large back pressure upon the sensor by reducing the opening of the outlet valve or by increasing the pump pressure. Thereby the size of air bubbles inside the sensor will be minimized. If the value or stability of "Driver current" falls, it is proof that the liquid contains air or gas bubbles.

### Typical causes of air in the liquid

- The entry pipe and sensor have not been properly filled with liquid. The pump cavitates, the rotary speed of the pump is too high in relation to the supply of liquid to the pump.
- The flow rate in the pipe is too high, so components sitting in front of the flowmeter can cause cavitation.
- If there is a filter installed before the flowmeter, it may be close to blocking, which also can cause cavitation.

### Solid particles in the liquid

If the solid particles in a liquid have a density higher than that of the liquid, they can precipitate inside the sensor and cause instability which leads to a measurement error.

If solid particles are present in the liquid, they must be homogeneously distributed and have the same density as the liquid. Otherwise they can cause relatively large measurement errors.

It is important that the sensor is installed such that solid particles can easily run out of the sensor.

- For MASS 2100 sensors this is achieved by a nearly horizontal installation with the entry highest and the outlet lowest.
- For MC2 sensors it is achieved by a vertical installation or by a nearly horizontal installation with the entry highest and the outlet lowest.

1. Check if solid particles are present in the liquid:  
Take a sample of the liquid, fill a glass and see if the solids precipitate.

## Technical data

<b>Measurement of</b>		Mass flow [kg/s], volume flow [l/s], fraction [%], Brix, density [kg/m <sup>3</sup> ], temperature [°C]	
<b>Digital outputs (2 x)</b>			
	Frequency	0-12 kHz, 50% mark-to-space ratio	
	Filter time constant	0-99.9 s	
	Connection	Passive, can be used as highside or lowside switch	
	Voltage	3-30 V DC	
	Current	0-30 mA, short-circuit-proof, protected against polarity reversal	
<b>Digital input</b>			
	Functionality	Batch control / totalizer control (resetting of totalizers) / zero setting / setting or freezing of a frequency at the digital outputs if these are set to "Frequency"	
	Voltage	15-30 V DC	
	Current	2 to 15 mA	
<b>Electrical isolation</b>		All inputs and outputs as well as the communication interfaces are electrically isolated, isolation voltage 500 V, according to IEC 61131-2:2003	
<b>Low-flow cut-off</b>			
	Low-flow quantity	0-9.9% of maximum flow	
<b>Limit function</b>		Mass flow, volume flow, fraction, density, sensor temperature	
<b>Totalizer</b>		Mass flow, volume flow, fraction, totalizer (SIMATIC: REAL 7-digits / MODBUS: DOUBLE 15-digits) for forward flow, net flow or reverse flow	
<b>Communication</b>			
	SIMATIC	SIMATIC backplane bus (P-bus)	
	MODBUS	RS232 or RS485, via front connector	
<b>Housing</b>			
	Material	Plastic (Noryl), dark gray	
	Dimensions (W x H x D)	<b>SIFLOW FC070</b>	<b>SIFLOW FC070 Ex CT</b>
		40 mm x 125 mm x 117 mm	80 mm x 125 mm x 117 mm
	Weight (without front connector)	<b>SIFLOW FC070</b>	<b>SIFLOW FC070 Ex CT</b>
		350 g	500 g
	Degree of protection	IP20	
	Load	Mechanical stress according to DIN EN 60068-2-x	
<b>Mechanical data</b>			

	Vibration during operation	According to IEC 60721-3-3, Part 3-3, IEC 61131-2, IEC 60068-2-6:1996, Class 3M3, Test Fc Test conditions: Frequency: 5..9 Hz, deflection: 3.5 mm, 10 cycles per axis, 1 octave/min. Frequency: 9..150 Hz, acceleration: 9.8 m/s <sup>2</sup> , 10 cycles per axis, 1 octave/min
	Shock during operation	According to IEC 61131-2, IEC 60068-2-27, Class 3M3, Test Ea Test conditions: Acceleration 150 m/s <sup>2</sup> , half sine, duration: 11 ms, 3 each in positive and negative directions per axis
<b>Electromagnetic compatibility (EMC)</b>		Emitted interference DIN EN 55011 Group 1, Class A (industrial environment) Noise immunity DIN EN 61000-6-2
<b>Protection element on power supply lines</b>		An external protection element should be fitted to meet the requirements, e. g.: DEHN BVT type AD24, No. 918402 (or equivalent)
<b>Namur</b>		According to recommendation NE21
<b>Climatic environmental conditions</b>		
	Ambient temperature for horizontally mounted rail	0 °C .. 60 °C For SIFLOW FC070 Ex CT: -40 °C ... 60 °C
	Ambient temperature for vertically mounted rail	0 °C .. 45 °C For SIFLOW FC070 Ex CT: -40 °C ... 45 °C
	Storage and transport temperature	-40 °C .. +70 °C
	Relative humidity	5 % .. 95 %
<b>Power supply</b>		Protected against polarity reversal
	Voltage	24 V DC, directly from the front, use also possible without power supply from SIMATIC bus board
	Tolerance	20.4 V DC – 28.8 V DC
	Power consumption	Max. 7.2 W
<b>Fuse</b>		Fuse T1 A, 125 V – cannot be replaced by user
<b>Certificates</b>		<b>SIFLOW FC070</b>
		<b>SIFLOW FC070 Ex CT</b>
		CE, cULus
		CE, cULus

Hazardous area approval	SIFLOW FC070	SIFLOW FC070 Ex CT
	ATEX Zone 2 EN 60079-15 II 3G Ex nA IIC T4 Gc KEMA 07 ATEX 0202 X  Use of function module in Zone 2 only with IP54 enclosure	For hazardous locations: ATEX, IECEx, cCSAus, cFMus Associated electrical apparatus with intrinsically safe inputs/ outputs (from/to Coriolis sensor) II 3G Ex nA IIC T4 Gc II (1)G [Ex ia] IIC Ga Special conditions ("X" conditions) must be observed. cFMus and cCSAus Class I, Zone 2, AEx nA [ia] IIC T4 Installation according to control drawing Use of function module in Zone 2 only with IP54 enclosure

## 15.1 MODBUS communication

Function	SIFLOW FC070 as MODBUS slave	
Physical layer	RS232 Point-to-point connection	RS485 Two-wire bus structure
Applied standard	ANSI / TIA / EIA-232-F-1997	ANSI / TIA / EIA-485-A-1998
Connection to SIFLOW FC070	<b>SIFLOW FC070</b> : front connector X1, pins 2...4 (1 = shield). <b>SIFLOW FC070 Ex CT</b> : front connector X2, pins 2...4 (1 = shield).	<b>SIFLOW FC070</b> : front connector X1, pins 5...10 (1 = shield). <b>SIFLOW FC070 Ex CT</b> : front connector X2, pins 5...10 (1 = shield).
Data transfer rates	0 = 1200 bit/s 1 = 2400 bit/s 2 = 4800 bit/s 3 = 9600 bit/s 4 = 19200 bit/s (default setting) 5 = 38400 bit/s 6 = 57600 bit/s 7 = 76800 bit/s 8 = 115200 bit/s	0 = 1200 bit/s 1 = 2400 bit/s 2 = 4800 bit/s 3 = 9600 bit/s 4 = 19200 bit/s (default setting) 5 = 38400 bit/s 6 = 57600 bit/s 7 = 76800 bit/s 8 = 115200 bit/s
Maximum transmission rate	115.2 kbit/s	115.2 kbit/s
Broadcast	-	No
Cable	Twisted conductor pair + ground, shielded	Twisted conductor pair, shielded
Maximum cable length	15 m	1200 m total length
Number of nodes	1	32
Slave device address	With DIP switch or with SIMATIC (HW Config) or with MODBUS itself	With DIP switch or with SIMATIC (HW Config) or with MODBUS itself
Bus termination	-	Selectable by inserting wire jumpers on last bus node

## 15.2 Block diagram of SIFLOW FC070

### Block diagram of SIFLOW FC070

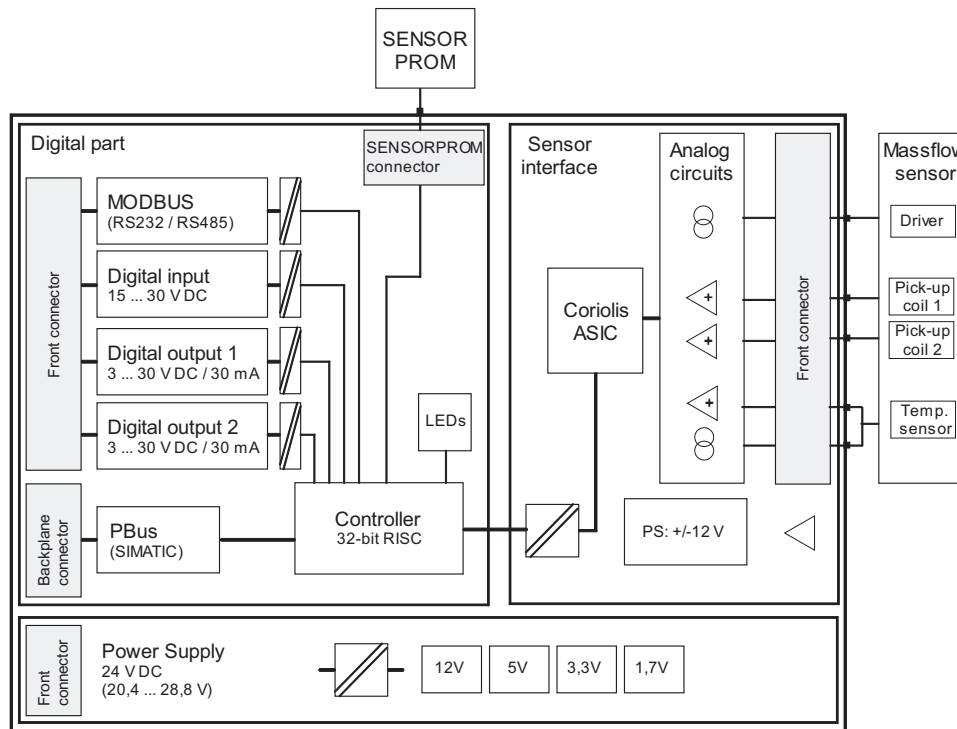

Figure 15-1 Block diagram of SIFLOW FC070

## 15.3 Block diagram of SIFLOW FC070 Ex CT

	<b>WARNING</b>
The installation guidelines and safety instructions given in this documentation and that listed below must be followed during commissioning and operation.	

It is essential to observe the "Fundamental rules and directives" as described for Ex function modules in the manual "S7-300 PLCs, ET 200M: Ex I/O modules".

### Please also note the following documentation

- SIMATIC system manual: Basics of explosion protection
- S7-300, ET 200M automation system manual: Ex I/O modules
- S7-300 automation system reference manual: Module Data



- SIMATIC S7-300, CPU 31xC and CPU 31x operating instructions: Installation
- SIMATIC S7-400 installation manual: Installation

All documentation is available at:

[http://www.automation.siemens.com/simatic/portal/html\\_76/techdoku.htm](http://www.automation.siemens.com/simatic/portal/html_76/techdoku.htm) ([http://www.automation.siemens.com/simatic/portal/html\\_76/techdoku.htm](http://www.automation.siemens.com/simatic/portal/html_76/techdoku.htm))

## 15.4 Triggering of commands via digital input

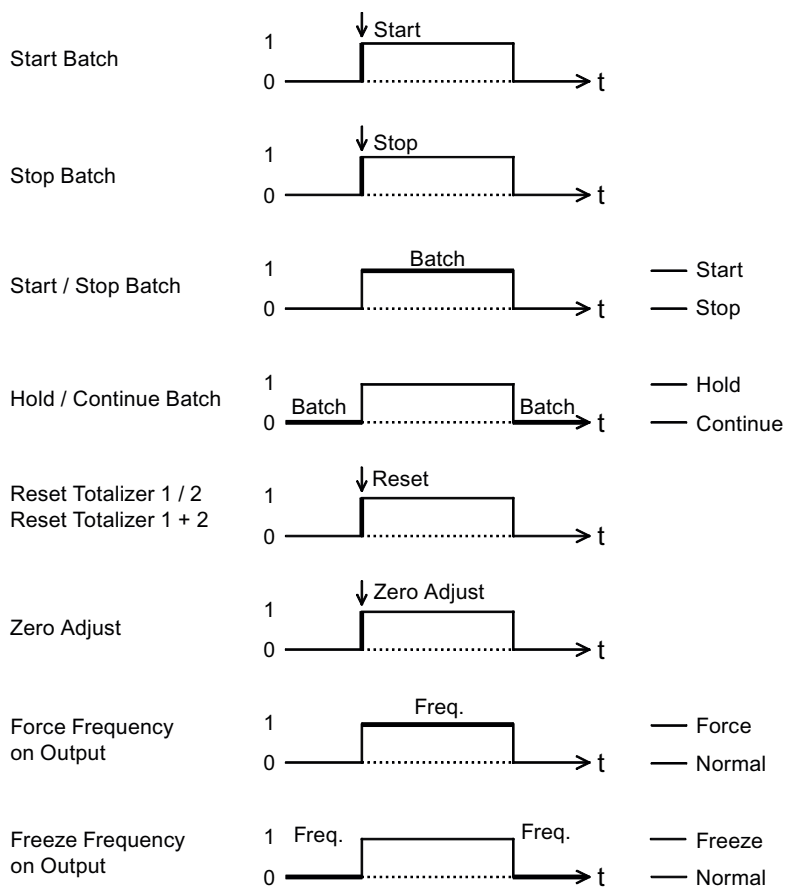
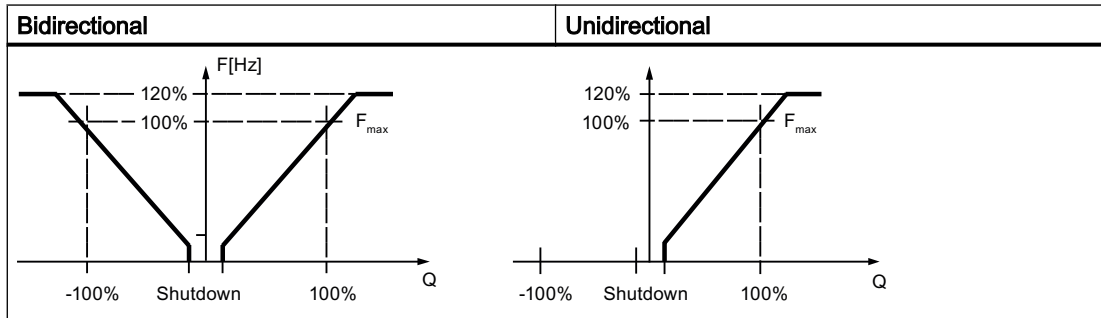

Figure 15-2 Characteristic input data (triggering of commands via digital input)

## 15.5 Output characteristics

### Frequency output



Frequency output with low-flow cut-off

### Pulse output

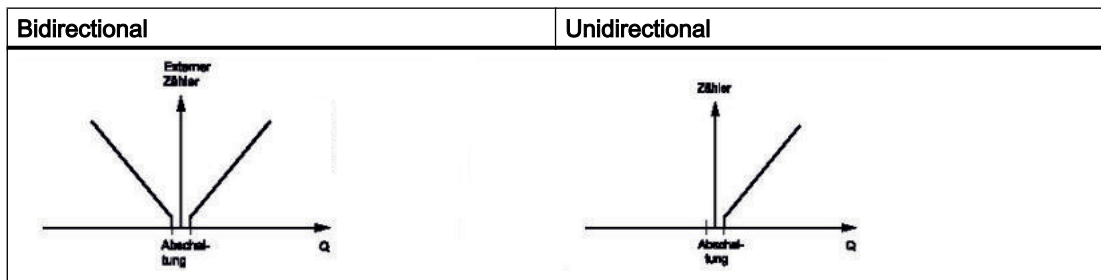

Pulse output with low-flow cut-off

### Batching (dosing) at digital output

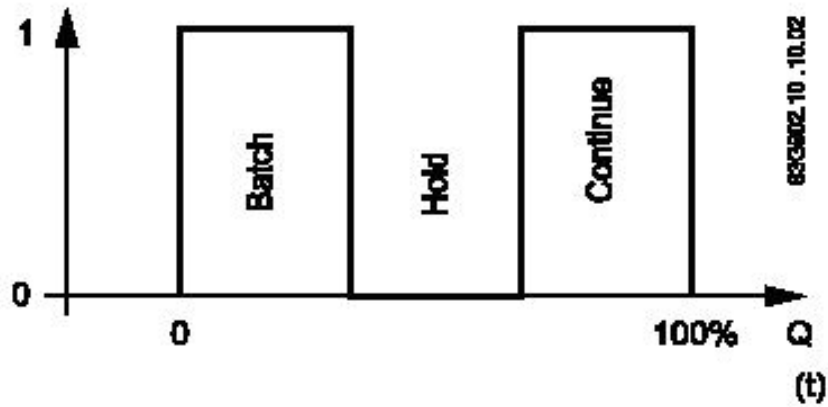

Figure 15-3 Batch mode

### Two stage batch

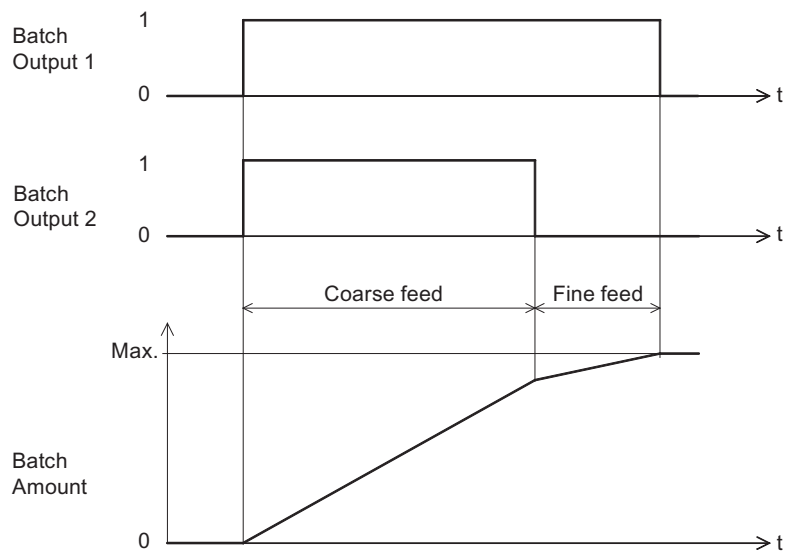

Figure 15-4 Two stage batch

Frequency output

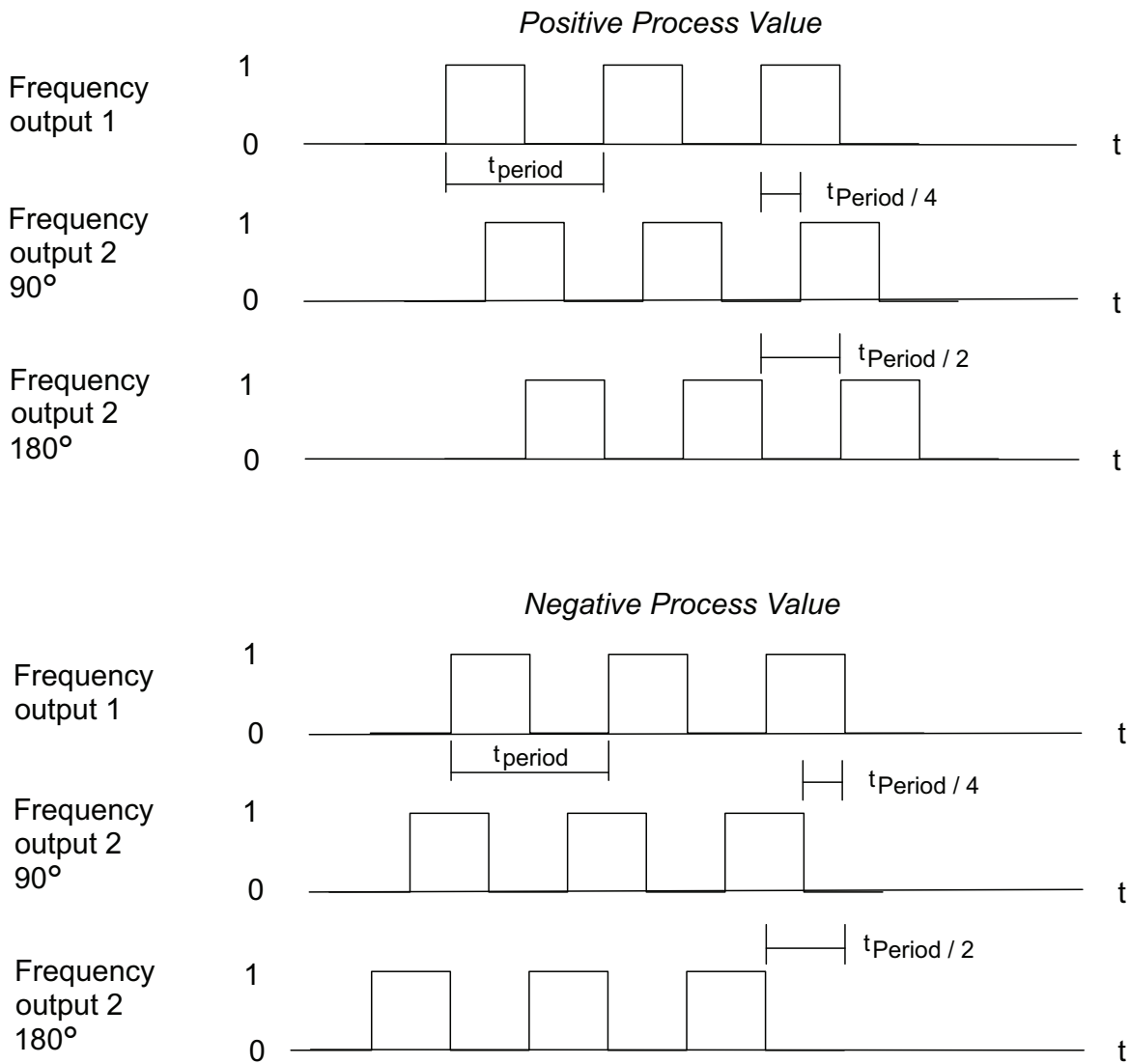

Figure 15-5 Phase shift at frequency output

Pulse output

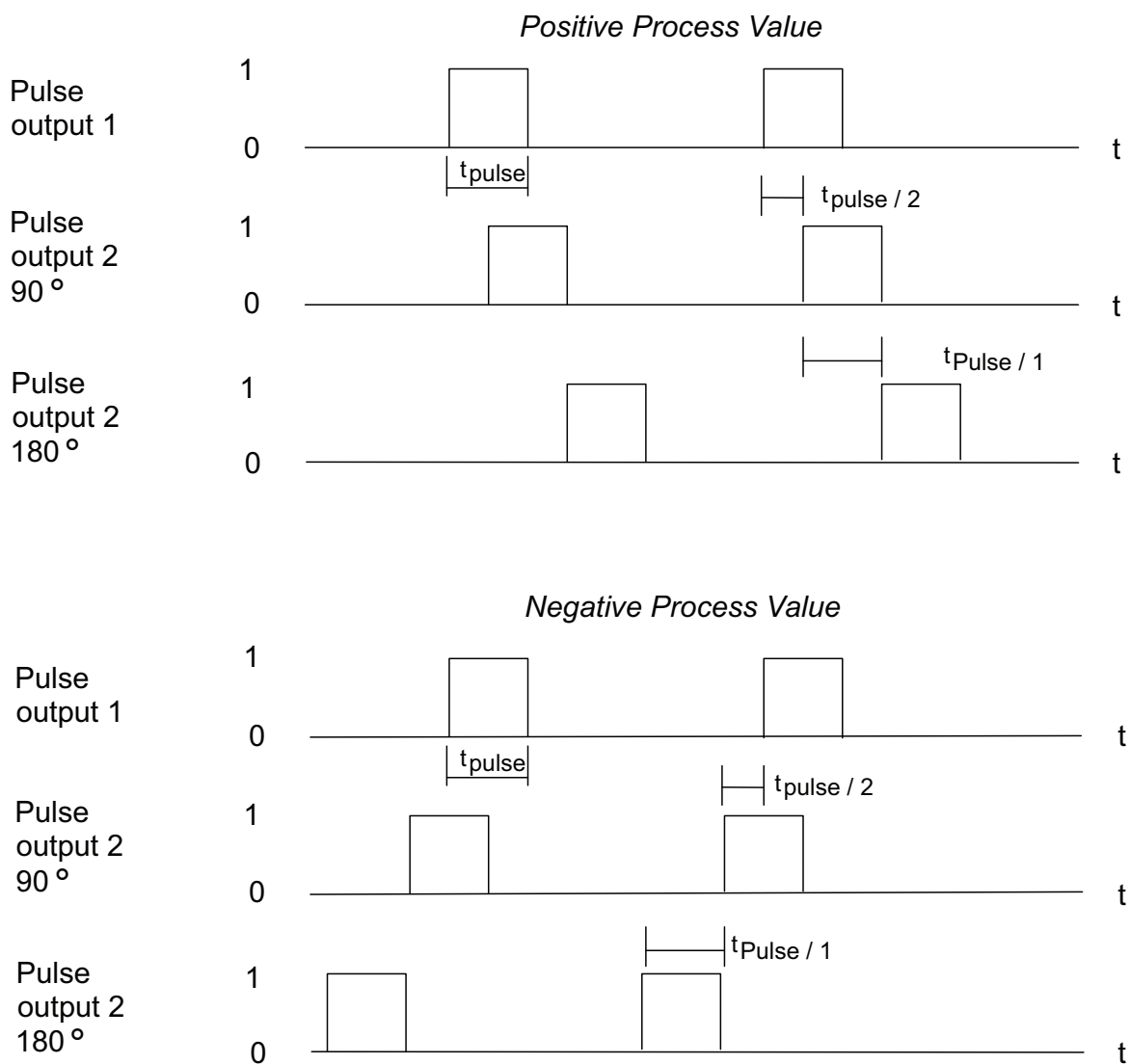

Figure 15-6 Phase shift at pulse output



## Spare parts/Accessories

### 16.1 Ordering

In order to ensure that the ordering data you are using is not outdated, the latest ordering data is always available on the Internet: Auto hotspot

### 16.2 Ordering data

Function modules	
	Order No.:
SIFLOW FC070	7ME4 120-2DH20-0EA0
SIFLOW FC070 Ex CT	7ME4 120-2DH21-0EA0

Accessories	
	Order No.:
40-pin front connector, for SIFLOW FC070	6ES7392-1AM00-0AA0
20-pin front connector, for SIFLOW FC070 Ex CT	6ES7392-1AJ00-0AA0
Cable with multiple plug for connection of MASS2100, FCS200 and FC300 sensors 5 m 10 m 25 m 50 m 75 m 150 m	FDK:083H3015 FDK:083H3016 FDK:083H3017 FDK:083H3018 FDK:083H3054 FDK:083H3055
Cable without multiple plug for connection of MC2 sensors 10 m 25 m 75 m 150 m	FDK:083H3001 FDK:083H3002 FDK:083H3003 FDK:083H3004
Shield connecting element (without terminals), 80 mm wide, for 2 x 4 terminal elements	6ES7390-5AA00-0AA0
Terminal element for one cable 3...8 mm diameter	6ES7390-5BA00-0AA0
Terminal element for one cable 4...13 mm diameter	6ES7390-5CA00-0AA0

SIMATIC S7-300 rails		
Mounting rail length	Usable length for modules	Order number:
160 mm	120 mm	6ES7 390
482.6 mm	450 mm	6ES7 390

16.2 Ordering data

SIMATIC S7-300 rails		
Mounting rail length	Usable length for modules	Order number:
530 mm	480 mm	6ES7 390
830 mm	780 mm	6ES7 390
2000 mm	cut to length as required	6ES7 390

In contrast to other rails, the 2 m mounting rail is not equipped with any fixing holes. These must be drilled, allowing optimal adaptation of the 2 m rail to your application.

For further accessories, see SIMATIC catalog or SIEMENS A&D Mall:

<https://mall.automation.siemens.com>



# SIFLOW Commands

## A.1 SIFLOW Commands

The SIFLOW commands are passed on directly to the module.

Table A-1 SIFLOW commands

Code	Name	Explanation
0	---	Invalid command code
1	CMD_BATCH_START	Start batch
2	CMD_BATCH_HOLD	Hold batch
3	CMD_BATCH_CONTINUE	Continue batch
4	CMD_BATCH_STOP	Stop batch
5	CMD_BATCH_CYCLE_COUNTER_RESET	Reset the counter batch_cycle_counter
6	CMD_TOTALIZER_1_RESET	Reset totalizer 1 to zero and restart counting
7	CMD_TOTALIZER_1_HOLD	Hold totalizer 1 (used in some cases when the pipes are being cleaned and you do not want to add cleaning fluid)
8	CMD_TOTALIZER_1_CONTINUE	Reactivate totalizer 1 after holding
9	CMD_TOTALIZER_1_PRESET	Preset totalizer 1 to the value totalizer1_preset_value and restart the counting operation
10	CMD_TOTALIZER_2_RESET	Reset totalizer 2 to zero and restart counting
11	CMD_TOTALIZER_2_HOLD	Hold totalizer 2 (used in some cases when the pipes are being cleaned and you do not want to add cleaning fluid)
12	CMD_TOTALIZER_2_CONTINUE	Reactivate totalizer 2 after holding
13	CMD_TOTALIZER_2_PRESET	Preset totalizer 2 to the value totalizer2_preset_value and restart the counting operation
14	CMD_TOTALIZER_1_2_RESET	Reset totalizer 1 + 2 to zero and restart counting
15	CMD_TOTALIZER_1_2_HOLD	Hold totalizer 1 + 2 (used in some cases when the pipes are being cleaned and you do not want to add cleaning fluid)
16	CMD_TOTALIZER_1_2_CONTINUE	Reactivate totalizer 1 + 2 after holding
17	CMD_TOTALIZER_1_2_PRESET	Set totalizer 1 to the value totalizer1_preset_value and totalizer 2 to the value totalizer2_preset_value and restart the counting operation
18	CMD_START_AUTO_ZERO_ADJUST	Start automatic zero adjustment
19	CMD_PARA_CHANGE_ACK	Confirm that changed parameters are detected Reset status bit ST_PARAMETER_CHANGED_BY_S7 if the origin of the command is Modbus. Reset status bit ST_PARAMETER_CHANGED_BY_MODBUS if the origin of the command is S7 P-Bus.
20	CMD_LOAD_FACTORY_VALUES	Reset all parameters to the factory settings Set status bit ST_FACTORY_VALUES_LOADED after all factory settings have been stored in the SENSORPROM
21	CMD_FREEZE_OUTPUT_ON	Freeze output value 1 + 2
22	CMD_FREEZE_OUTPUT_OFF	Switch from frozen output value 1 + 2 to normal output value

## SIFLOW Commands

### A.1 SIFLOW Commands

Code	Name	Explanation
23	CMD_FORCE_OUTPUT_ON	Set (force) output value 1 + 2
24	CMD_FORCE_OUTPUT_OFF	Switch from the set output value to normal output value
25	CMD_ZERO_OFFSET_VALUE_PRESET	Set DR31 → zero_offset_value to the value DR11 → zero_offset_preset_value
26 ... 250	Reserved	
251	CMD_PERI_700_VARS	S7 peri control area: New value in one of the following fields: input_var_addr, input_var_value, digital_output, output_var1_addr, output_var2_addr
252	CMD_PERI_701_IN_VAR	S7 peri control area: New value in the input_var_addr or input_var_value field
253	CMD_PERI_702_DIGITAL_OUTPUT	S7 peri control area: New value in the digital_output field
254	CMD_PERI_703_OUT_VAR1_ADDR	S7 peri control area: New value in the output_var1_addr field
255	CMD_PERI_704_OUT_VAR2_ADDR	S7 peri control area: New value in the output_var2_addr field

---

#### Note

It is not possible to use the SIFLOW commands via PDM when using Profibus access from ET200M.

---

# SIFLOW Units

# B

Table B-1 Units for mass flow

ID	Unit	Description
00	kg / s	kilograms per second
01	g / s	grams per second
02	g / min	grams per minute
03	g / h	grams per hour
04	g / d	grams per day
05	kg / min	kilograms per minute
06	kg / h	kilograms per hour
07	kg / d	kilograms per day
08	t / s	metric tons per second
09	t / min	metric tons per minute
10	t / h	metric tons per hour
11	t / d	metric tons per day
12	lb / s	pounds per second
13	lb / min	pounds per minute
14	lb / h	pounds per hour
15	lb / d	pounds per day
16	STONS / s	short tons per second (1 STons = 2000 pounds)
17	STONS / min	short tons per minute
18	STONS / h	short tons per hour
19	STONS / d	short tons per day
20	LTONS / s	long tons per second
21	LTONS / min	long tons per minute
22	LTONS / h	long tons per hour
23	LTONS / d	long tons per day
24	mg / s	milligrams per second
25	mg / min	milligrams per minute
26	mg / h	milligrams per hour
27	mg / d	milligrams per day

Table B-2 Units for volume flow

ID	Unit	Description
00	m <sup>3</sup> / s	cubic meters per second
01	m <sup>3</sup> / min	cubic meters per minute

ID	Unit	Description
02	m <sup>3</sup> / h	cubic meters per hour
03	m <sup>3</sup> / d	cubic meters per day
04	l / s	liters per second
05	l / min	liters per minute
06	l / h	liters per hour
07	l / d	liters per day
08	MI / d	megaliters per day
09	ft <sup>3</sup> / s	cubic feet per second
10	ft <sup>3</sup> / min	cubic feet per minute
11	ft <sup>3</sup> / h	cubic feet per hour
12	ft <sup>3</sup> / d	cubic feet per day
13	gal / s	US gallons per second
14	gal / min	US gallons per minute
15	gal / h	US gallons per hour
16	gal / d	US gallons per day
17	Mgal / d	Mega US gallons per day
18	ImpGal / s	Imperial gallons per second
19	ImpGal / min	Imperial gallons per minute
20	ImpGal / h	Imperial gallons per hour
21	ImpGal / d	Imperial gallons per day
22	bbl / s	barrels per second
23	bbl / min	barrels per minute
24	bbl / h	barrels per hour
25	bbl / d	barrels per day
26	μgal / s	micro US gallons per second
27	mgal / s	milli US gallons per second
28	kgal / s	kilo US gallons per second
29	Mgal / s	mega US gallons per second
30	μgal / min	micro US gallons per minute
31	mgal / min	milli US gallons per minute
32	kgal / min	kilo US gallons per minute
33	Mgal / min	mega US gallons per minute
34	μgal / h	micro US gallons per hour
35	mgal / h	milli US gallons per hour
36	kgal / h	kilo US gallons per hour
37	Mgal / h	mega US gallons per hour
38	μgal / d	micro US gallons per day
39	mgal / d	milli US gallons per day
40	kgal / d	kilo US gallons per day
41	μImpGal / s	micro imperial gallons per second
42	mImpGal / s	milli imperial gallons per second
43	kImpGal / s	kilo imperial gallons per second
44	MImpGal / s	mega imperial gallons per second

ID	Unit	Description
45	$\mu\text{ImpGal} / \text{min}$	micro imperial gallons per minute
46	$\text{mImpGal} / \text{min}$	milli imperial gallons per minute
47	$\text{kImpGal} / \text{min}$	kilo imperial gallons per minute
48	$\text{MImpGal} / \text{min}$	mega imperial gallons per minute
49	$\mu\text{ImpGal} / \text{h}$	micro imperial gallons per hour
50	$\text{mImpGal} / \text{h}$	milli imperial gallons per hour
51	$\text{kImpGal} / \text{h}$	kilo imperial gallons per hour
52	$\text{MImpGal} / \text{h}$	mega imperial gallons per hour
53	$\mu\text{ImpGal} / \text{d}$	micro imperial gallons per day
54	$\text{mImpGal} / \text{d}$	milli imperial gallons per day
55	$\text{kImpGal} / \text{d}$	kilo imperial gallons per day
56	$\text{MimpGal} / \text{d}$	mega imperial gallons per day
57	$\mu\text{bbl} / \text{s}$	micro barrels per second
58	$\text{mbbl} / \text{s}$	milli barrels per second
59	$\text{kbbl} / \text{s}$	kilo barrels per second
60	$\text{Mbbl} / \text{s}$	mega barrels per second
61	$\mu\text{bbl} / \text{min}$	micro barrels per minute
62	$\text{mbbl} / \text{min}$	milli barrels per minute
63	$\text{kbbl} / \text{min}$	kilo barrels per minute
64	$\text{Mbbl} / \text{min}$	mega barrels per minute
65	$\mu\text{bbl} / \text{h}$	micro barrels per hour
66	$\text{mbbl} / \text{h}$	milli barrels per hour
67	$\text{kbbl} / \text{h}$	kilo barrels per hour
68	$\text{Mbbl} / \text{h}$	mega barrels per hour
69	$\mu\text{bbl} / \text{d}$	micro barrels per day
70	$\text{mbbl} / \text{d}$	milli barrels per day
71	$\text{kbbl} / \text{d}$	kilo barrels per day
72	$\text{Mbbl} / \text{d}$	mega barrels per day
73	$\mu\text{m}^3 / \text{s}$	cubic micrometers per second
74	$\text{mm}^3 / \text{s}$	cubic millimeters per second
75	$\text{km}^3 / \text{s}$	cubic kilometers per second
76	$\text{Mm}^3 / \text{s}$	cubic megameters per second
77	$\mu\text{m}^3 / \text{min}$	cubic micrometers per minute
78	$\text{mm}^3 / \text{min}$	cubic millimeters per minute
79	$\text{km}^3 / \text{min}$	cubic kilometers per minute
80	$\text{Mm}^3 / \text{min}$	cubic megameters per minute
81	$\mu\text{m}^3 / \text{h}$	cubic micrometers per hour
82	$\text{mm}^3 / \text{h}$	cubic millimeters per hour
83	$\text{km}^3 / \text{h}$	cubic kilometers per hour
84	$\text{Mm}^3 / \text{h}$	cubic megameters per hour
85	$\mu\text{m}^3 / \text{d}$	cubic micrometers per day
86	$\text{mm}^3 / \text{d}$	cubic millimeters per day
87	$\text{km}^3 / \text{d}$	cubic kilometers per day

ID	Unit	Description
88	Mm <sup>3</sup> / d	cubic megameters per day
89	cm <sup>3</sup> / s	cubic centimeters per second
90	cm <sup>3</sup> / min	cubic centimeters per minute
91	cm <sup>3</sup> / h	cubic centimeters per hour
92	cm <sup>3</sup> / d	cubic centimeters per day
93	kl / min	kiloliters per minute
94	kl / h	kiloliters per hour
95	kl / d	kiloliters per day
96	ml/min	milliliters per minute
97	ft <sup>3</sup> / s	cubic feet per second
98	ft <sup>3</sup> / min	cubic feet per minute
99	ft <sup>3</sup> / h	cubic feet per hour
100	ft <sup>3</sup> / d	cubic feet per day
101	in <sup>3</sup> / s	cubic inches per second
102	in <sup>3</sup> / min	cubic inches per minute
103	in <sup>3</sup> / h	cubic inches per hour
104	in <sup>3</sup> / d	cubic inches per day
105	MI / s	megaliters per second
106	MI / min	megaliters per minute
107	MI / h	megaliters per hour
108	MI / d	megaliters per day

Table B-3 Units for density

ID	Unit	Description
00	Kg / m <sup>3</sup>	kilograms per cubic meter
01	Mg / m <sup>3</sup>	megagrams per cubic meter
02	kg / dm <sup>3</sup>	kilograms per cubic decimeter
03	g / cm <sup>3</sup>	grams per cubic centimeter
04	g / m <sup>3</sup>	grams per cubic meter
05	t / m <sup>3</sup>	metric tons per cubic meter
06	kg / l	kilograms per liter
07	g / ml	grams per milliliter
08	g / l	grams per liter
09	lb / in <sup>3</sup>	pounds per cubic inch
10	lb / ft <sup>3</sup>	pounds per cubic foot
11	lb / gal	pounds per US gallon
12	STONS / yd <sup>3</sup>	short tons per cubic yard (1 STons = 2000 pounds)
13	mg / l	milligrams per liter
14	µg / l	micrograms per liter
15	mg / dm <sup>3</sup>	milligrams per cubic decimeter
16	mg / l	milligrams per liter (do not use in new projects)

ID	Unit	Description
17	mg / m <sup>3</sup>	milligrams per cubic meter
18	lb / m <sup>3</sup>	pounds per cubic meter
19	kg / ft <sup>3</sup>	kilograms per cubic foot
20	t / ft <sup>3</sup>	metric tons per cubic foot
21	mg / ft <sup>3</sup>	milligrams per cubic foot
22	g / ft <sup>3</sup>	grams per cubic foot
23	kg / in <sup>3</sup>	kilograms per cubic inch
24	t / in <sup>3</sup>	tons per cubic inch
25	mg / in <sup>3</sup>	milligrams per cubic inch
26	lb / in <sup>3</sup>	pounds per cubic inch
27	kg / cm <sup>3</sup>	kilograms per cubic centimeter
28	t / cm <sup>3</sup>	metric tons per cubic centimeter
29	lb / cm <sup>3</sup>	pounds per cubic centimeter
30	mg / cm <sup>3</sup>	milligrams per cubic centimeter

Table B-4 Units for temperature

ID	Unit	Description
00	K	Kelvin
01	°C	Degree Celsius
02	°F	Degree Fahrenheit

Table B-5 Units for mass

ID	Unit	Description
00	kg	kilogram
01	g	gram
02	mg	milligram
03	Mg	megagram
04	t	metric ton
05	oz	ounce
06	lb	pound (mass)
07	STONS	short tons (2000 pounds)
08	LTONS	long tons (2240 pounds)

Table B-6 Units for volume

ID	Unit	Description
00	m <sup>3</sup>	cubic meter
01	dm <sup>3</sup>	cubic decimeter

ID	Unit	Description
02	cm <sup>3</sup>	cubic centimeter
03	mm <sup>3</sup>	cubic millimeter
04	l	liter
05	cl	centiliter
06	ml	milliliter
07	hl	hectoliter
08	in <sup>3</sup>	cubic inch
09	ft <sup>3</sup>	cubic foot
10	yd <sup>3</sup>	cubic yard
11	gal	US gallon
12	ImpGal	Imperial gallon
13	bushel	bushel
14	bbl	barrels (42 USG)
15	bbl (liq)	barrels liquid (31.5 USG)
16	Kl	kiloliter
17	Ml	Megaliter
18	Mgal	US mega gallon
19	MImpGal	Imperial mega gallon
20	Mkgal	US kilo gallon
21	MImpkGal	Imperial kilo gallon



# Data records



The data records listed below are described in detail in the following sections.

Table C-1 Data records in the data block DB\_FLOW\_PARA

DS No.	Contents	Read/write	Description
<b>Commands</b>			
	DB_Length		Length of the DB
	Max. lifebit cycle		Lifebit monitoring
	SFB error code		Communication error RET_VAL SFB 52 / 53
	All call parameters of FB95		See section on use in SIMATIC S7, communication with the function module
<b>Parameters</b>			
2	Units	R / W	Settings for units
3	Basic parameter	R / W	Settings for basic settings
4	Totalizer parameter	R / W	Settings for totalizer 1 + 2
5	Digital output parameter	R / W	Settings for digital output
6	Digital input parameter	R / W	Settings for digital input
7	COM interface parameter	R / W	Settings for P-Bus and RS 485 interface
8	Date & time parameter	R / W	Settings for date & time
9	Sensor characteristic parameter	R / W	Setting the sensor properties
10	Simulation parameter	R / W	Settings of the simulation values
11	Process preset parameter	R / W	Setting the process default settings
12	Limit parameter	R / W	Setting the limit default settings
39	CT parameters	R / W	Setting CT parameters
<b>Process, service, product data</b>			
30	Flowmeter process information	R	Current process data
31	Service information	R	Service information data
32	Transmitter information	R	Transmitter data
33	Sensor information	R	Sensor data
34	Customer information	R	Customer data
35	MODBUS ID information	R	MODBUS data
36	MODBUS service information	R	MODBUS data
37	CT values	R	CT data

C.1 DR2 Units of the process values (R/W)

**Note**

Min./max. values are integrated in the tables for better clarity. The relationship between a data record and its associated min./max. values is as follows:

- Min. values: DR No. + 40 corresponds to the associated "Min." data record
- Max. values: DR No. + 80 corresponds to the associated "Max." data record.

Example: for DR 4, the min. values are in DR 44, and the max. values in DR 84.

The min./max. values are only module-internal values, i.e. the user program has no access to the min./max. data records.

**Note**

Sensor dimension dependent parameters are read from the SENSORPROM®.

## C.1 DR2 Units of the process values (R/W)

All units are described in the "Table of units" (Page 195)

Table C-2 Units of the process values (all units have SI as default unit)

Offset in the DB_FLOW_PARA	MODBUS addr	Parameter	Label	Data type (Number of bytes)	Value range and description
80.0		Process value units		STRUCT	Unit ID (default unit)
80.0	2904	massflow_unit	Massflow unit	BYTE (1)	0 ... 27 kg/s Default setting = 0 kg/s
81.0	2906	volumeflow_unit	Volumeflow unit	BYTE (1)	0 ... 108 m³/s Default setting = 0 m³/s
82.0	2916	density_unit	Density unit	BYTE (1)	0 ... 29 kg/ m³ Default setting = 0 kg/ m³
83.0	4110	temparature_unit	Temperature unit	BYTE (1)	0 ... 2 °C Default setting = 1 °C
84.0	2908	fraction_unit	Fraction unit	BYTE (1)	Value range depends on DR33: fraction_value_selection <ul style="list-style-type: none"> <li>• DR33: fraction_value_selection = 0 -&gt; range = 0 ... 27 (massflow, kg/s)</li> <li>• DR33: fraction_value_selection = 1 -&gt; range = 0 ... 108 (volumeflow, m³/s)</li> </ul> Default setting = 0 kg/s

## C.1 DR2 Units of the process values (R/W)

Offset in the DB_FLOW_PARA	MODBUS addr	Parameter	Label	Data type (Number of bytes)	Value range and description
80.0		Process value units		STRUCT	Unit ID (default unit)
85.0	2912	totalizer_1_unit	Totalizer 1 unit	BYTE (1)	<p>Value range depends on DR4: totalizer_1_selection and DR33: fraction_value_selection</p> <ul style="list-style-type: none"> <li>DR4: totalizer_1_selection = 1 -&gt; range = 0 ... 8 (mass, kg)</li> <li>DR4:totalizer_1_selection = 2 or 3 and DR33:fraction_value_selection = 0 -&gt; range = 0 ... 8 (mass, kg)</li> <li>DR4:totalizer_1_selection = 2 or 3 and DR33:fraction_value_selection = 1 -&gt; range = 0 ... 21 (volume, m<sup>3</sup>)</li> <li>DR4:totalizer_1_selection = 4 -&gt; range = 0 ... 21 (volume, m<sup>3</sup>)</li> </ul> <p>Default setting = 0 kg</p>
86.0	2914	totalizer_2_unit	Totalizer 2 unit	BYTE (1)	<p>Value range depends on DR4: totalizer_2_selection and DR33: fraction_value_selection</p> <ul style="list-style-type: none"> <li>DR4: totalizer_2_selection = 1 -&gt; range = 0 ... 8 (mass, kg)</li> <li>DR4: totalizer_2_selection = 2 or 3 and DR33: fraction_value_selection = 0 -&gt; range = 0 ... 8 (mass, kg)</li> <li>DR4: totalizer_2_selection = 2 or 3 and DR33: fraction_value_selection = 1 -&gt; range = 0 ... 21 (volume, m<sup>3</sup>)</li> <li>DR4: totalizer_2_selection = 4 -&gt; range = 0 ... 21 (volume, m<sup>3</sup>)</li> </ul> <p>Default setting = 0 kg</p>
87.0	2918	batch_unit	Batch unit	BYTE (1)	<p>Value range depends on DR5: batch_value_selection and DR33: fraction_value_selection</p> <ul style="list-style-type: none"> <li>DR5: batch_value_selection = 1-&gt; range = 0 ... 8 (mass, kg)</li> <li>DR5: batch_value_selection = 2 or 3 and DR33: fraction_value_selection = 0 -&gt; range = 0 ... 8 (mass, kg)</li> <li>DR5: batch_value_selection = 2 or 3 and DR33: fraction_value_selection = 1 -&gt; range = 0 ... 21 (volume, m<sup>3</sup>)</li> <li>DR5: batch_value_selection = 4 -&gt; range = 0 ... 21 (volume, m<sup>3</sup>)</li> </ul> <p>Default setting = 0 kg</p>

## C.2 DR3 Basic settings (R/W)

Offset in the DB_FLOW_PARA	MODBUS addr	Parameter	Label	Data type (Number of bytes)	Value range and description
80.0		Process value units		STRUCT	Unit ID (default unit)
88.0	2920	pulse_amount_unit	Pulse amount unit	BYTE (1)	Value range depends on DR5: pulse_value_selection and DR33: fraction_value_selection <ul style="list-style-type: none"> <li>DR5: pulse_value_selection = 1 -&gt; range = 0 ... 8 (mass, kg)</li> <li>DR5: pulse_value_selection = 2 or 3 and DR33: fraction_value_selection = 0 -&gt; range = 0 ... 8 (mass, kg)</li> <li>DR5: pulse_value_selection = 2 or 3 and DR33: fraction_value_selection = 1 -&gt; range = 0 ... 21 (volume, m<sup>3</sup>)</li> <li>DR5: pulse_value_selection = 4 -&gt; range = 0 ... 21 (volume, m<sup>3</sup>)</li> </ul> Default setting = 0 kg
89.0	---	reserve_1	Reserved	BYTE (1)	---
90.0	---	reserve_2	Reserved	BYTE (1)	---
91.0	---	reserve_3	Reserved	BYTE (1)	---

## C.2 DR3 Basic settings (R/W)

Table C-3 Basic settings

Offset in DB_FLOW_PARA	MODBUS S addr.	Parameter	Label	Data type (Number of bytes)	Value range and description
92.0		General settings		STRUCT	
92.0		reserve_1	Reserved	BYTE (1)	
93.0		reserve_2	Reserved	BYTE (1)	
94.0		reserve_3	Reserved	BYTE (1)	
95.0	2029	empt_pipe_det_on_off	Empty pipe detection	BYTE (1)	Function for empty pipe check on/off <ul style="list-style-type: none"> <li>0= off</li> <li>1= on</li> </ul> Default setting = 0
96.0	2027	empty_pipe_limit	Empty pipe limit	REAL (4)	Error if density lower than empty pipe limit <ul style="list-style-type: none"> <li>Min: -20000.0</li> <li>Max: +20000.0</li> </ul> Default setting = 500 0.0 ... +20000.0 in steps of 0.1 [density unit]

Offset in DB_FLOW_PARA	MODBUS addr.	Parameter	Label	Data type (Number of bytes)	Value range and description
92.0		<b>General settings</b>		<b>STRUCT</b>	
100.0	2025	low_flow_cut_off	Low flow cut off	REAL (4)	If massflow lower than low_flow_cut_off * massflow_max, then massflow forced to zero <ul style="list-style-type: none"> <li>Min: 0</li> <li>Max: 0.1</li> </ul> Default setting = 0.015
104.0	2000	flow_direction	Flow direction	BYTE (1)	<ul style="list-style-type: none"> <li>0= Negative</li> <li>1= Positive</li> </ul> Default setting = 0
105.0	2030	noise_filter	Noise filter	BYTE (1)	1 = min. ... 5 = max. Default setting = 4
106.0	2031	error_level	Error level	BYTE (1)	SE and PE error filters for Error Pending List and Error Log List to MODBUS <ul style="list-style-type: none"> <li>1= Failure</li> <li>2= Maintenance request</li> <li>3= Check</li> <li>4= Outside specification</li> </ul> Default setting = 1 SE / PE error filter is activated after database update by SENSORPROM, all previous errors pass the filter.
107.0	---	reserve_4	Reserved	BYTE (1)	
108.0	2001	Massflow_max	Massflow max	REAL (4)	Sensor dimension dependent Unit: DR2: massflow unit Range: MassflowScaleUpperMin ... MassflowScaleUpperMax (kg/s) Default setting: 31.25 kg/s (installation without SENSORPROM)
112.0	2003	volumeflow_max	Volumeflow max	REAL (4)	Sensor dimension dependent Unit: DR2: volumeflow unit Range: VolumeflowScaleUpperMin ... VolumeflowScaleUpperMax (m <sup>3</sup> /s) Default setting = 0.001556 m <sup>3</sup> /s (installation without SENSORPROM)
116.0	2011	density_max	Density max	REAL (4)	Unit: DR2: density unit <ul style="list-style-type: none"> <li>Min: -20000 kg/m<sup>3</sup></li> <li>Max: +20000 kg/m<sup>3</sup></li> </ul> Default setting = 2000 kg/m <sup>3</sup>
120.0	2015	sensor_temperature_max	Sensor temperature max	REAL (4)	Sensor dimension dependent Unit: DR2: temperature unit <ul style="list-style-type: none"> <li>Min: -250°C</li> <li>Max: +250°C</li> </ul> Default setting = 180°C (installation without SENSORPROM)

Data records

C.2 DR3 Basic settings (R/W)

Offset in DB_FLOW_PARA	MODBUS addr.	Parameter	Label	Data type (Number of bytes)	Value range and description
92.0		<b>General settings</b>		<b>STRUCT</b>	
124.0	2017	fraction_A_flow_max	Fraction A flow max	REAL (4)	Value range depends on DR33: fraction_value_selection: <ul style="list-style-type: none"> <li>DR33: fraction_value_selection = 0 -&gt; range = MassflowScaleUpperMin ... MassflowScaleUpperMax (kg/s)</li> <li>DR33: fraction_value_selection = 1 -&gt; range = VolumeflowScaleUpperMin ... VolumeflowScaleUpperMax (m³/s)</li> </ul> Default setting = 31.25 kg/s or 0.001556 m³/s (installation without SENSORPROM)
128.0	2019	fraction_B_flow_max	Fraction B flow max	REAL (4)	Value range depends on DR33: fraction_value_selection: <ul style="list-style-type: none"> <li>DR33: fraction_value_selection = 0 -&gt; range = MassflowScaleUpperMin ... MassflowScaleUpperMax (kg/s)</li> <li>DR33: fraction_value_selection = 1 -&gt; range = VolumeflowScaleUpperMin ... VolumeflowScaleUpperMax (m³/s)</li> </ul> Default setting = 31.25 kg/s or 0.001556 m³/s (installation without SENSORPROM)
132.0	2023	percent_fraction_A_max	Percent fraction A max	REAL (4)	On display and in data record in %, e.g. value 80.1 = 80.1 % <ul style="list-style-type: none"> <li>Min: 0%</li> <li>Max: +2900%</li> </ul> Default setting = 100
136.0	4102	Massflow_min	Massflow min	REAL (4)	Sensor dimension dependent Unit: DR2: massflow unit Range: -MassflowScaleUpperMax ... MassflowScaleUpperMax (kg/s) Default setting = 0
140.0	4104	volumeflow_min	Volumeflow min	REAL (4)	Sensor dimension dependent Unit: DR2-> volumeflow unit Range: -VolumeflowScaleUpperMax ... VolumeflowScaleUpperMax (m³/s) Default setting = 0
144.0	2009	density_min	Density min	REAL (4)	Unit: DR2: density unit <ul style="list-style-type: none"> <li>Min: -20000</li> <li>Max: +20000</li> </ul> Default setting = 100

Offset in DB_FLOW_PARA	MODBUS addr.	Parameter	Label	Data type (Number of bytes)	Value range and description
92.0		<b>General settings</b>		<b>STRUCT</b>	
148.0	2013	sensor_temperature_min	Sensor temperature min	REAL (4)	Sensor dimension dependent Unit: DR2-> temperature unit <ul style="list-style-type: none"> <li>Min: -250°C</li> <li>Max: +250°C</li> </ul> Default setting = -50°C (installation without SENSORPROM)
152.0	4106	fraction_A_flow_min	Fraction A flow min	REAL (4)	Value range depends on DR33: fraction_value_selection: <ul style="list-style-type: none"> <li>DR33: fraction_value_selection = 0 -&gt; range = MassflowScaleUpperMin ... MassflowScaleUpperMax (kg/s)</li> <li>DR33: fraction_value_selection = 1 -&gt; range = VolumeflowScaleUpperMin ... VolumeflowScaleUpperMax (m³/s)</li> </ul> Default setting = 0 kg/s
156.0	4108	fraction_B_flow_min	Fraction B flow min	REAL (4)	Value range depends on DR33: fraction_value_selection: <ul style="list-style-type: none"> <li>DR33: fraction_value_selection = 0 -&gt; range = MassflowScaleUpperMin ... MassflowScaleUpperMax (kg/s)</li> <li>DR33: fraction_value_selection = 1 -&gt; range = VolumeflowScaleUpperMin ... VolumeflowScaleUpperMax (m³/s)</li> </ul> Default setting = 0
160.0	2021	percent_fraction_A_min	Percent fraction A min	REAL (4)	On display and in data record in %, e.g. value 80.1 = 80.1 % <ul style="list-style-type: none"> <li>Min: 0</li> <li>Max: Percent fraction A max</li> </ul> Default setting = 0
164.0	---	reserve_5	Reserved	ARRAY [0 .. 1] (2)	---
166.0	2035	zero_adjust_time	Zero adjust time	WORD (2)	Duration of zero adjust in seconds (for progress, see zero adjust progress in DR31 (Page 228)) <ul style="list-style-type: none"> <li>Min: 0</li> <li>Max: 65535 s</li> </ul> Default setting = 30
168.0	2038	zero_sigma_limit	Zero sigma limit	REAL (4)	Max. allowed zero sigma by automatic zero adjust Unit: DR2: massflow unit <ul style="list-style-type: none"> <li>Min: 0</li> <li>Max: FLT_MAX kg/s</li> </ul> Default setting = --- (read from SENSORPROM)

C.3 DR4 Totalizer (R/W)

Offset in DB_FLOW_PARA	MODBUS addr.	Parameter	Label	Data type (Number of bytes)	Value range and description
92.0		<b>General settings</b>		<b>STRUCT</b>	
172.0	4112	zero_offset_limit	Zero offset limit	REAL (4)	Sensor dimension dependent Max. zero offset of automatic and manual zero adjust values Unit: DR2: massflow unit <ul style="list-style-type: none"> <li>Min: 0</li> <li>Max: FLT_MAX kg/s</li> </ul> Default setting = 250.0 (installation without SENSORPROM)
176.0	---	reserve_6	Reserved	ARRAY [0 .. 1] (2)	---
178.0	640	tag	Tag	STRING (18)	Any 18 character long string
198.0	5300	descriptor	Descriptor	STRING (20)	Any 20 character long string

### C.3 DR4 Totalizer (R/W)

Table C-4 Totalizer (R/W)

Offset in DB_FLOW_PARA	MODBUS addr	Parameter	Label	Data type (Number of bytes)	Value range and description
220.0		<b>Totalizer 1</b>		<b>STRUCT</b>	
220.0	2100	totalizer_1_selection	Totalizer 1 selection	BYTE (1)	<ul style="list-style-type: none"> <li>1 = Mass (flow)</li> <li>2 = Fraction A</li> <li>3 = Fraction B</li> <li>4 = Volume (flow)</li> </ul> Default setting = 1
221.0	2101	totalizer_1_direction	Totalizer 1 direction	BYTE (1)	<ul style="list-style-type: none"> <li>0 = Negative (reverse: only backward)</li> <li>1 = Positive (forward: only forward)</li> <li>2 = Balanced (net: + if forward / - if backward)</li> </ul> Default setting = 1
222.0	4204	totalizer_1_fail_mode	Totalizer 1 fail mode	BYTE (1)	If Namur error class F (Page 151) is pending. <ul style="list-style-type: none"> <li>0 = RUN: totalize using actual flow value</li> <li>1 = HOLD: totalizer is held (like Hold totalizer)</li> <li>2 = MEMORY: totalize using the last incoming value with good status</li> </ul> Default setting = 1
223.0	---	reserve_1	Reserved	BYTE (1)	---



Offset in DB_FLOW_PAR A	MODBUS addr	Parameter	Label	Data type (Number of bytes)	Value range and description
220.0		<b>Totalizer 1</b>		<b>STRUCT</b>	
224.0	2102	totalizer_2_selection	Totalizer 1 selection	BYTE (1)	<ul style="list-style-type: none"> <li>• 1 = Mass (flow)</li> <li>• 2 = Fraction A</li> <li>• 3 = Fraction B</li> <li>• 4 = Volume (flow)</li> </ul> Default setting = 1
225.0	2103	totalizer_2_direction	Totalizer 1 direction	BYTE (1)	<ul style="list-style-type: none"> <li>• 0 = Negative (reverse: only backward)</li> <li>• 1 = Positive (forward: only forward)</li> <li>• 2 = Balanced (net: + if forward / - if backward)</li> </ul> Default setting = 1
226.0	4206	totalizer_2_fail_mode	Totalizer 1 fail mode	BYTE (1)	If Namur error class F (Page 151) is pending. <ul style="list-style-type: none"> <li>• 0 = RUN: totalize using actual flow value</li> <li>• 1 = HOLD: totalizer is held (like Hold totalizer)</li> <li>• 2 = MEMORY: totalize using the last incoming value with good status</li> </ul> Default setting = 1
227.0	---	reserve_2	Reserved	BYTE (1)	

## C.4 DR5 Digital output (R/W)

Table C-5 Digital output (R/W)

Offset in DB_FLOW_PAR A	MODBUS addr	Parameter	Label	Data type (Number of bytes)	Value range and description
228.0		<b>Digital output general</b>		<b>STRUCT</b>	
228.0	4300	dig_out_sf_reaction	Digital output SF reaction	BYTE (1)	Digital output reaction at system fault (SF): <ul style="list-style-type: none"> <li>0 = No special reaction at SF</li> <li>1 = Set outputs to OFF (switch of the output driver)</li> <li>2 = Set outputs to ON</li> <li>3 = Set output 1 to max. frequency, output 2 off</li> <li>4 = Set output 2 to max. frequency, output 1 off</li> </ul> Default setting = 0
229.0	2205	dig_out_func	Digital output function	BYTE (1)	<ul style="list-style-type: none"> <li>0 = Of</li> <li>1 = Pulse</li> <li>2 = Frequency</li> <li>3 = Redundancy pulse 90°</li> <li>4 = Redundancy frequency 90°</li> <li>5 = Two-stage batch</li> <li>6 = Batch</li> <li>7 = Redundancy pulse 180°</li> <li>8 = Redundancy frequency 180°</li> </ul> Default setting = 0
230.0	---	reserve_1	Reserved	ARRAY [0 .. 1] (2)	---
232.0	2206	pulse_value_selection	Pulse value selection	BYTE (1)	Only active if digital output function is pulse: <ul style="list-style-type: none"> <li>1 = Mass (flow)</li> <li>2 = Fraction A</li> <li>3 = Fraction B</li> <li>4 = Volume (flow)</li> </ul> Default setting = 1
233.0	4380	pulse_output_polarity	Pulse output polarity	BYTE (1)	<ul style="list-style-type: none"> <li>0 = open, i.e. no current when pulse (DO1 LED off)</li> <li>1 = closed, i.e. current when pulse (DO1 LED on)</li> </ul> Default setting = 0
234.0	2207	pulse_direction	Pulse direction	BYTE (1)	<ul style="list-style-type: none"> <li>1 = Unidirectional</li> <li>2 = Bidirectional</li> </ul> Default setting = 1

Offset in DB_FLOW_PARA	MODBUS addr	Parameter	Label	Data type (Number of bytes)	Value range and description
228.0		Digital output general		STRUCT	
235.0	2208	pulse_width	Pulse width	BYTE (1)	<ul style="list-style-type: none"> <li>• 0 = 64 µs</li> <li>• 1 = 130 µs</li> <li>• 2 = 260 µs</li> <li>• 3 = 510 µs</li> <li>• 4 = 1.0 ms</li> <li>• 5 = 2.0 ms</li> <li>• 6 = 4.1 ms</li> <li>• 7 = 8.2 ms</li> <li>• 8 = 16 ms</li> <li>• 9 = 33 ms</li> <li>• 10 = 66 ms</li> <li>• 11 = 130 ms</li> <li>• 12 = 260 ms</li> <li>• 13 = 520 ms</li> <li>• 14 = 1.0 s</li> <li>• 15 = 2.1 s</li> <li>• 16 = 4.2 s</li> </ul> Default setting = 4
236.0	2290	pulse_mass_or_vol_amnt	Pulse mass or volume amount	REAL (4)	Value range depends on DR5: pulse_value_selection and DR2: pulse_amount_unit: Range 10 <sup>-12</sup> ... 10 <sup>8</sup> kg resp. 10 <sup>-18</sup> ... 100.000 m <sup>3</sup> Default setting = 6 kg
240.0	2210	frequency_value_sel	Frequency value selection	BYTE (1)	Only active if digital output function is frequency: <ul style="list-style-type: none"> <li>• 1 = Mass flow</li> <li>• 2 = Fraction A flow</li> <li>• 3 = Fraction B flow</li> <li>• 4 = Volume flow</li> <li>• 5 = Sensor temperature</li> <li>• 6 = Density</li> <li>• 7 = % Fraction A</li> </ul> Default setting = 1
241.0	2211	frequency_direction	Frequency direction	BYTE (1)	Frequency 1 direction <ul style="list-style-type: none"> <li>• 1 = Unidirectional (only positive flow)</li> <li>• 2 = Bidirectional</li> </ul> Default setting = 1

Data records

C.4 DR5 Digital output (R/W)

Offset in DB_FLOW_PARAMETER_A	MODBUS addr	Parameter	Label	Data type (Number of bytes)	Value range and description
228.0		<b>Digital output general</b>		<b>STRUCT</b>	
242.0	2212	frequency_max	Frequency max	BYTE (1)	Frequency Fmax. (50% duty cycle): <ul style="list-style-type: none"> <li>• 0 = 10 kHz</li> <li>• 1 = 5 kHz</li> <li>• 2 = 1 kHz</li> <li>• 3 = 500 Hz</li> </ul> Default setting = 0
243.0	---	reserve_2	Reserved	BYTE (1)	---
244.0	2213	frequency_time_const	Frequency time constant	REAL (4)	Frequency 1 time constants (used to filter/smoothen the output): 0 ... 60.0 s in steps of 0.1 seconds Default setting = 5
248.0	2233	batch_val_sel	Batch value selection	BYTE (1)	Only active if digital output function is batch (must be set before DR11: batch_quantity): <ul style="list-style-type: none"> <li>• 1 = Mass (flow)</li> <li>• 2 = Fraction A</li> <li>• 3 = Fraction B</li> <li>• 4 = Volume (flow)</li> </ul> Default setting = 1
249.0	2246	batch_count_up_down	Batch counter up/down	BYTE (1)	<ul style="list-style-type: none"> <li>• 0 = Down (DR11: batch_quantity to 0)</li> <li>• 1 = Up (0 to DR11: batch_quantity)</li> </ul> Default setting = 0
250.0	4302	batch_output_polarity	Batch output polarity	BYTE (1)	<ul style="list-style-type: none"> <li>• 0 = Open, i.e. no current, if batch active (DO1 LED off)</li> <li>• 1 = Closed, i.e. current, if batch active (DO1 LED on)</li> </ul> Default setting = 0
251.0	2240	batch_time_error_on_off	Batch time error on/off	BYTE (1)	<ul style="list-style-type: none"> <li>• 0 = Off</li> <li>• 1 = On</li> </ul> Default setting = 0
252.0	2243	batch_overrun_on_off	Batch overrun on/off	BYTE (1)	<ul style="list-style-type: none"> <li>• 0 = Off</li> <li>• 1 = On</li> </ul> Default setting = 0
253.0	---	reserve_3	Reserved	BYTE (1)	---
254.0	---	reserve_4	Reserved	ARRAY [0 .. 1] (2)	---

Offset in DB_FLOW_PARA	MODBUS addr	Parameter	Label	Data type (Number of bytes)	Value range and description
228.0		Digital output general		STRUCT	
256.0	2241	batch_time_max	Maximum batch time	REAL (4)	<p>Only active if b_Batch_time_err_on_off = 1</p> <ul style="list-style-type: none"> <li>• Min: 0</li> <li>• Max: 360000 s</li> </ul> <p>Default setting = 1</p> <p>Error PE29 PE_BATCH_TIMEOUT is set if batch_time_max is reached before batch is ready</p>
260.0	2244	batch_overrun_err_quant	Batch overrun error quantity	REAL (4)	<p>Only active if b_Batch_overrun_err_on_off = 1</p> <p>Unit: kg or m<sup>3</sup> in dependence on batch_value_selection and batch_unit</p> <ul style="list-style-type: none"> <li>• Min: 0</li> <li>• Max: 999999</li> </ul> <p>Default setting = 0</p> <p>Error PE30 PE_BATCH_OVERRUN is set if quantity exceeds DR11 -&gt; batch_quantity with more than batch_overrun_error_quantity (delta)</p>

## C.5 DR6 Digital input (R/W)

Table C-6 Digital input (R/W)

Offset in DB_FLOW_PARA	MODBUS addr	Parameter	Label	Data type (Number of bytes)	Value range and description
264.0		Digital input general		STRUCT	
264.0	4404	digital_input_sf_reaction	Digital input SF reaction	BYTE (1)	Digital input reaction with system fault (SF): <ul style="list-style-type: none"> <li>0 = No special reaction with SF</li> <li>1 = Off</li> <li>2 = On</li> </ul> Default setting = 0
265.0	2300	digital_input_function	Digital input function	BYTE (1)	<ul style="list-style-type: none"> <li>0 = Off</li> <li>1 = Start batch (rising edge)</li> <li>2 = Stop batch (rising edge)</li> <li>3 = Start/stop batch (level: 1 = Start, 0 = Stop)</li> <li>4 = Hold/continue batch (level: 1 = Hold, 0 = Continue)</li> <li>5 = Reset totalizer 1 (rising edge)</li> <li>6 = Reset totalizer 2 (rising edge)</li> <li>7 = Reset totalizers T1+T2 (rising edge)</li> <li>8 = Zero adjust (rising edge)</li> <li>9 = Force frequency on output (level: 1 = Force, 0 = Normal)</li> <li>10 = Freeze frequency on output (level: 1 = Freeze, 0 = Normal)</li> </ul> Default setting = 0
266.0	4400	input_filter_time	Input filter time	BYTE (1)	<ul style="list-style-type: none"> <li>0 = Without firmware filter</li> <li>1 ... 255 ms in steps of 1 ms</li> </ul> Default setting = 0
267.0	4402	input_inversion	Input inversion	BYTE (1)	<ul style="list-style-type: none"> <li>0 = unchanged (3-30 V = High; &lt;3 V = Low)</li> <li>1 = inverted (3-30 V = Low; &lt;3 V = High)</li> </ul> Default setting = 0
268.0	2302	force_frequency_output_value	Force frequency output value	REAL (4)	0% .... +125% of DR5: frequency_max (on display in %, in data record as factor, e.g. 0,1 => 10%). Default setting = 0 The output is forced to this value if digital_input_function is set to Force output and digital input takes High level, if input_inversion = 0

## C.6 DR7 Interface parameters (R/W)

Table C-7 Interface parameters (R/W)

Offset in DB_FLOW_PARA	MODBUS addr	Parameter	Label	Data type (Number of bytes)	Value range and description
272.0		<b>SIMATIC P-bus interface</b>		<b>STRUCT</b>	
272.0	4100	Standalone	Standalone	BYTE (1)	Note: can be changed in write protection mode. <ul style="list-style-type: none"> <li>0= No (SIMATIC mode)</li> <li>1= Yes (standalone mode / all errors according to missing S7 CPU suppressed)</li> </ul> Default setting = 0
273.0	---	reserve_1	Reserved	BYTE (1)	---
274.0	5000	s7_peri_output_var1_assignment	S7 output value 1	WORD (2)	Note: can be changed in write protection mode. MODBUS address of the value to be displayed in s7_status_signals-> output_var_1_value <ul style="list-style-type: none"> <li>Min: 2</li> <li>Max: 2</li> </ul> Default setting = 3000 (massflow)
276.0	5002	s7_peri_output_var2_assignment	S7 output value 2	WORD (2)	Note: can be changed in write protection mode. MODBUS address of the value to be displayed in s7_status_signals-> output_var_2_value <ul style="list-style-type: none"> <li>Min: 2</li> <li>Max: 2</li> </ul> Default setting = 3002 (volumeflow)
278.0	5004	s7_pral0_assignment	S7 process alarm 0	WORD (2)	Process alarm 0 assignment (only valid values should be set) Value 0: No process alarm (default) <ul style="list-style-type: none"> <li>Range of values 1 – FFh: Error No. of coming Handling errors, see table "Data and operator errors (Page 156)"</li> <li>Range of values 100h – 17Fh: 100h+ 0 ... 1Fh: Bit No. of coming status flag, see table "System status information (Page 162)"</li> <li>Range of values 200h – 27Fh: 200h+ 0 ... 1Fh: Bit No. of going status flag, see table "System status information (Page 162)"</li> <li>Range of values 300h – 37Fh: 300h+ 0 ... 7Fh: Error No. of coming SE or PE errors, see table "Sensor and process errors (Page 149)"</li> <li>Range of values 400h – 47Fh: 400h+ 0 ... 7Fh: Error No. of going SE or PE errors, see table "Sensor and process errors (Page 149)"</li> </ul> Default setting = 0
280.0	5006	s7_pral1_assignment	S7 process alarm 1	WORD (2)	Note: can be changed in write protection mode. Process alarm 1 assignment ditto Default setting = 0

Data records

C.6 DR7 Interface parameters (R/W)

Offset in DB_FLOW_PARA	MODBUS addr	Parameter	Label	Data type (Number of bytes)	Value range and description
272.0		<b>SIMATIC P-bus interface</b>		<b>STRUCT</b>	
282.0	5008	s7_pral2_assignment	S7 process alarm 2	WORD (2)	Note: can be changed in write protection mode. Process alarm 2 assignment ditto Default setting = 0
284.0	5010	s7_pral3_assignment	S7 process alarm 3	WORD (2)	Note: can be changed in write protection mode. Process alarm 3 assignment ditto
286.0	5012	s7_pral4_assignment	S7 process alarm 4	WORD (2)	Note: can be changed in write protection mode. Process alarm 4 assignment ditto Default setting = 0
288.0	5014	s7_pral5_assignment	S7 process alarm 5	WORD (2)	Note: can be changed in write protection mode. Process alarm 5 assignment ditto
290.0	5016	s7_pral6_assignment	S7 process alarm 6	WORD (2)	Note: can be changed in write protection mode. Process alarm 6 assignment ditto Default setting = 0
292.0	5018	s7_pral7_assignment	S7 process alarm 7	WORD (2)	Note: can be changed in write protection mode. Process alarm 7 assignment ditto Default setting = 0
294.0	---	reserve_2	Reserved	ARRAY [0 .. 1] (2)	---
296.0	5020	s7_lifebit_timeout	S7 lifebit timeout	TIME	Note: can be changed in write protection mode. <ul style="list-style-type: none"> <li>• 0 = Lifebit timeout off</li> <li>• 1 to 100000 = Lifebit timeout on with timeout in (ms)</li> </ul> Default setting = 0
300.0	529	modbus_baudrate	MODBUS baudrate	BYTE (1)	RS232 / RS485-Baudrate: <ul style="list-style-type: none"> <li>• 0 = 1200 bit/s</li> <li>• 1 = 2400 bit/s</li> <li>• 2 = 4800 bit/s</li> <li>• 3 = 9600 bit/s</li> <li>• 4 = 19200 bit/s (default)</li> <li>• 5 = 38400 bit/s</li> <li>• 6 = 57600 bit/s</li> <li>• 7 = 76800 bit/s</li> <li>• 8 = 115200 bit/s</li> </ul> Default setting = 4
301.0	530	modbus_parity_fram	MODBUS parity framing	BYTE (1)	RS232 / RS485 parity and framing: <ul style="list-style-type: none"> <li>• 0 = 8, E, 1 (default)</li> <li>• 1 = 8, O, 1</li> <li>• 2 = 8, N, 2</li> <li>• 3 = 8, N, 1</li> </ul> Default setting = 0



Offset in DB_FLOW_PARA	MODBUS addr	Parameter	Label	Data type (Number of bytes)	Value range and description
272.0		<b>SIMATIC P-bus interface</b>		STRUCT	
302.0	511	modbus_response_timeou	MODBUS response timeout	WORD (2)	Max. response time. Used in time-critical applications where low cycle times are required. If the response is not ready within the "Response timeout" time, an exception code 6 is returned and the request must be sent again. Range: 100 ... 25500 ms in steps of 1 ms Default setting = 10000
304.0	512	w_modbus_response_delay	MODBUS response delay	WORD (2)	The minimum time from when a slave receives a request until it returns a response. This makes it possible to send data to slow masters without overloading its receiver. Range: 0 ... 255 ms in steps of 1 ms Default setting = 1
306.0	513	modbus_interframe_space	MODBUS interframe space	BYTE (1)	The minimum interframe space between two successive MODBUS RTU messages Range: 3.5 ... 25 characters in steps of 0.1 characters (35 = 3.5) Default setting = 35
307.0	---	reserve_3	Reserved	BYTE (1)	---

## C.7 DR8 Day/time (R/W)

Table C-8 Date and time (R/W)

Offset in DB_FLOW_PARA	MODBUS addr	Parameter	Label	Data type (Number of bytes)	Value range and description
308.0	4004	date_and_time	Date and time	DATE_AND_TIME (8)	SIMATIC date and time format: <ul style="list-style-type: none"> <li>• Day.month.year</li> <li>• Hour:minute:second millisecond</li> <li>• Week day</li> </ul> Default setting = 01.01.06 / 00:00:00 / 000 Mo

## C.8 DR9 Sensor properties (R/W)

Table C-9 Sensor properties (R/W)

Offset in DB_FLOW_PARA	MODBUS addr	Parameter	Label	Data type (Number of bytes)	Value range and description
316.0	2400	sensor_size	Sensor size	REAL (4)	Value from SENSORPROM giving the tube diameter (m) <ul style="list-style-type: none"> <li>Min: 0</li> <li>Max: 9.9</li> </ul> Default setting = 0.035682
320.0	2402	Calibration_factor	Calibration factor	REAL (4)	Used to calculate the flow rate (s <sup>2</sup> /kg). Sensor-specific, calculated during the factory wet calibration, stored in the SENSORPROM, and written on the sensor label. <ul style="list-style-type: none"> <li>Min: -10000</li> <li>Max: +10000</li> </ul> Default setting = 0.0001
324.0	2404	correction_factor	Correction factor	REAL (4)	Range: -FLT_MAX...FLT_MAX (SIFLOW FC070 treats this factor as a normal number and not as a percentage value, 1.0 in the device is 100 %) Default setting = 1
328.0	2406	sensor_TC	Sensor temperature coefficient	REAL (4)	Temperature coefficient (%/C) for the specific sensor is found under the flow calibration. <ul style="list-style-type: none"> <li>Min: -0.8</li> <li>Max: +0.8</li> </ul> Default setting = -0.0005 A PT1000 temperature sensor is mounted on the MASS2100 sensor, and a PT100 on the MC2. With this temperature, with which the sensors are mounted, the transmitter is able to compensate temperature changes in the sensors.
332.0	2408	density_parm_A	Density parameter A	REAL (4)	Density parameter A is a constant found under the density calibration. Standard sensors without density calibration have average values stored in the SENSORPROM. Range: -FLT_MAX ... + FLT_MAX (density unit) Default setting = - 1000
336.0	2410	density_parm_B	Density parameter B	REAL (4)	Density parameter B is a constant found under the density calibration. Standard sensors without density calibration have average values stored in the SENSORPROM. Range: -FLT_MAX ... + FLT_MAX (density unit) Default setting = - 1E8

Offset in DB_FLOW_PARA	MODBUS addr	Parameter	Label	Data type (Number of bytes)	Value range and description
340.0	2412	r_Density_TC	Density temperature coefficient	REAL (4)	Density temperature coefficient %/°C Density TC is found under the density calibration. Standard sensors without density calibration have average values stored in the SENSORPROM. <ul style="list-style-type: none"> <li>Min: -3.2</li> <li>Max: +3.2</li> </ul> Default setting = -0.0005
344.0	2414	density_offset	Density offset	REAL (4)	With this function you are able to make an offset in the measured density (kg/m <sup>3</sup> ). <ul style="list-style-type: none"> <li>Min: -9999.9999</li> <li>Max: +9999.9999</li> </ul> Default setting = 0 If you want the flowmeter to show + 2 kg/m <sup>3</sup> more, you can change the density offset to 02.000 Kg/ m <sup>3</sup> in the 'Sensor' menu
348.0	2416	density_factor	Density factor	REAL (4)	With this factor you are able to make a density correction in % on the flowmeter. <ul style="list-style-type: none"> <li>Min: -9.999999</li> <li>Max: +9.999999</li> </ul> Default setting = 1 The SIFLOW FC070 treats this factor as a normal number and not as a percentage value: 1.0 in the device is 100 %. If you want to change the density on the flowmeter by +0.5 %, you have to change the correction factor to 1.005. After the change the flowmeter will now show a density about 0.5 % higher than before.
352.0	2418	fraction_factor	Fraction factor	REAL (4)	Fraction factor (= b Table slope): <ul style="list-style-type: none"> <li>Min: -9999.9999</li> <li>Max: +9999.9999</li> </ul> Default setting = 1 The SIFLOW FC070 treats this factor as a normal number and not as a percentage value: 1.0 in the device is 100 %. Example: If you want to change the concentration in % on the flowmeter by +0.5 %, you have to change the fraction factor 'b' to 1.005. Afterwards the flowmeter will show a concentration 0.5 % higher than before.
356.0	2421	fraction_offset	Fraction offset	REAL (4)	Fraction offset (= a) <ul style="list-style-type: none"> <li>Min: -9999.9999</li> <li>Max: +9999.9999</li> </ul> Default setting = 0

## C.9 DR10 Simulation data (R/W)

Table C-10 Simulation data (R/W)

Offset in DB_FLOW_PARA	MODBUS addr	Parameter	Label	Data type (Number of bytes)	Value range and description
360.0		Enable		STRUCT	
360.0	4500	Simulation_enable	Enable simulation	WORD (2)	Simulation: <ul style="list-style-type: none"> <li>• 0= disable</li> <li>• 1= enable <ul style="list-style-type: none"> <li>– Bit 00: simulation_value_massflow</li> <li>– Bit 01: simulation_value_volume_flow</li> <li>– Bit 02: simulation_value_density</li> <li>– Bit 03: simulation_value_sensor_temperature</li> <li>– Bit 04: free</li> <li>– Bit 05: free</li> <li>– Bit 06: simulation_value_fraction_a_percent</li> <li>– Bit 07: simulation_value_output1</li> <li>– Bit 08: simulation_value_output2</li> <li>– Bit 09: simulation_value_input</li> <li>– Bit 10: simulation_value_error_no</li> <li>– Bit 11 ... 15 free</li> </ul> </li> </ul> Default setting = 0
362.0	---	reserve_1	Reserved	ARRAY [0 .. 1] (2)	---
364.0	4502	simulation_value_massflow	Simulate massflow value	REAL (4)	Active if simulation enable for massflow (bit 0) Unit: DR2: massflow_unit Range: DR3: massflow_min -20% of range (max-min) ... DR3: massflow_max + 20% of range (max-min) Default setting = 0
368.0	4504	simulation_value_volume_flow	Simulate volume_flow value	REAL (4)	Active if simulation enable for volume_flow (bit 1) Unit: DR2: volume_flow_unit Range: DR3: volume_flow_min -20% of range (max-min) ... DR3: volume_flow_max + 20% of range (max-min) Default setting = 0
372.0	4506	simulation_value_density	Simulate density value	REAL (4)	Active if simulation enable for density (bit 2) Unit: DR2: density_unit Range: DR3: density_min -20% of range (max-min) ... DR3 : density_max+ 20% of range (max-min) Default setting = 1000

Offset in DB_FLOW_PARA	MODBUS addr	Parameter	Label	Data type (Number of bytes)	Value range and description
360.0		Enable		STRUCT	
376.0	4508	simulation_value_sensor_temperature	Simulate sensor temperature value	REAL (4)	Active if simulation enable for temperature (bit 3) Unit: DR2: temperature_unit Range: DR3: sensor_temperature_min – 20% of range (max-min) ... DR3: sensor_temperature_max + 20% of range (max-min) Default setting = 0
380.0	4514	simulation_value_percent_fraction_a	Simulate fraction A percent	REAL (4)	Active if simulation enable for % fraction A (bit 6) Range: DR3: percent_fraction_a_min – 20% of range (max-min) ... DR3: percent_fraction_a_max + 20% of range (max-min) Default setting = 0 On display and in data record in %, e.g. value 80.1 = 80.1 %
384.0	---	reserve_2	Reserved	BYTE (1)	---
385.0	---	reserve_3	Reserved	BYTE (1)	---
386.0	---	reserve_4	Reserved	BYTE (1)	---
387.0	4516	simulation_value_output_1	Simulate output 1 signal	BYTE (1)	Active if simulation enable for output (Bit 7) Does not depend on selected output function in DR5 <ul style="list-style-type: none"> <li>• 0=off</li> <li>• 1=on</li> <li>• 2=frequency</li> </ul> Default setting = 0
388.0	4518	simulation_value_output_1_frequency	Simulate frequency output 1	DWORD (4)	Active if simulation_value_output = frequency (Hz) <ul style="list-style-type: none"> <li>• Min: 0</li> <li>• Max: 12500</li> </ul> Default setting = 10000
392.0	---	reserve_5	Reserved	BYTE (1)	---
393.0	---	reserve_6	Reserved	BYTE (1)	---
395.0	4520	simulation_value_output_2	Simulate output 2 signal	BYTE (1)	Active if simulation enable for output (Bit 8) Does not depend on selected output function in DR5 <ul style="list-style-type: none"> <li>• 0=off</li> <li>• 1=on</li> <li>• 2=frequency</li> </ul> Default setting = 0
396.0	4522	simulation_value_output_2_frequency	Simulate frequency output 2	DWORD (4)	Active if simulation_value_output = frequency (Hz) <ul style="list-style-type: none"> <li>• Min: 0</li> <li>• Max: 12500</li> </ul> Default setting = 10000

C.10 DR11 Process value default settings (R/W)

Offset in DB_FLOW_W_PARA	MODBUS addr	Parameter	Label	Data type (Number of bytes)	Value range and description
360.0		Enable		STRUCT	
400.0	4524	simulation_value_input	Simulate input signal	BYTE (1)	Active if simulation enable for input (Bit 9) <ul style="list-style-type: none"> <li>0=low (off)</li> <li>1=high (on)</li> </ul> Default setting = 0
401.0	4526	simulation_value_error_no	Simulate error number	BYTE (1)	Active if simulation enable for error_no (Bit 10) Range: 1 ... 255 (only SE and PE errors, no HE errors) Default setting = 1
402.0	---	reserve_8	Reserved	ARRAY [0 .. 1] (2)	---

See also

Simulation (Page 122)

C.10 DR11 Process value default settings (R/W)

Table C-11 Process value default settings (R/W)

Offset in DB_FLOW_PARA	MODBUS addr	Parameter	Label	Data type (Number of bytes)	Value range and description
404.0	2234	batch_quantity	Batch quantity	REAL (4)	Unit: mass (kg) or volume (m <sup>3</sup> ) depending on batch_value_selection (see table "Data record 2" (Page 202)) Setpoint: desired quantity to batch <ul style="list-style-type: none"> <li>Min: 0</li> <li>Max: 999999</li> </ul> Default setting = 5
408.0	2236	batch_compensation	Batch compensation	REAL (4)	Unit: mass (kg) or volume (m <sup>3</sup> ) depending on batch_value_selection (see table "Data record 2" (Page 202)) Fixed quantity to add or subtract in order to compensate for valve delay etc. <ul style="list-style-type: none"> <li>Min: -100</li> <li>Max: +100</li> </ul> Default setting = 0
412.0	2238	batch_lead_constant	Batch lead constant	REAL (4)	Dynamic compensation of batch quantity Range: 0 ... 16.77s in steps of 0.001seconds Default setting = 0

## C.10 DR11 Process value default settings (R/W)

Offset in DB_FLOW_PARA	MODBUS addr	Parameter	Label	Data type (Number of bytes)	Value range and description
416.0	4304	batch_two_stage_level	Batch two stage level	REAL (4)	Batch stage level for switching off output 2: Range: 0 ... +100% in steps of 0.01% Default setting: 0 First stage if two-stage batching on, e.g. value 80 = 80 % of selected value in batch quantity
420.0	4200	totalizer_1_preset_value	Totalizer 1 preset value	REAL (4)	According to selected source: Unit: DR2: massflow_unit or DR2: volumeflow_unit Range: -FLT_MAX ... +FLT_MAX Default setting = 0
424.0	4202	totalizer_2_preset_value	Totalizer 2 preset value	REAL (4)	According to selected source: Unit: DR2: massflow_unit or DR2: volumeflow_unit Range: -FLT_MAX ... +FLT_MAX Default setting = 0
428.0	2033	zero_offset_preset_value	Zero offset preset value	REAL (4)	Reported in DR1: zero_offset_value Unit: DR2: massflow_unit Range: -FLT_MAX ... +FLT_MAX Default setting = 0

## C.11 DR12 Limit default settings (R/W)

Table C-12 Limited default settings (R/W) (can be changed in write protection mode)

Offset in DB_FLOW_PARA	MODBUS addr	Parameter	Label	Data type (Number of bytes)	Value range and description
432.0		Limit		STRUCT	
432.0	4600	limit1_selection	Limit 1 selection	BYTE (1)	<ul style="list-style-type: none"> <li>• 0 = Off</li> <li>• 1 = Mass flow</li> <li>• 2 = Fraction A</li> <li>• 3 = Fraction B</li> <li>• 4 = Volume flow</li> <li>• 5 = Sensor temperature</li> <li>• 6 = Density</li> <li>• 7 = Totalizer 1</li> <li>• 8 = Totalizer 2</li> <li>• 9 = % Fraction A</li> </ul> Default setting = 0
433.0	4602	limit1_direction	Limit 1 direction	BYTE (1)	<ul style="list-style-type: none"> <li>• 0 = Low limit (limit status coming at setpoint, going at setpoint + hysteresis)</li> <li>• 1 = High limit (limit status coming at setpoint, going at setpoint - hysteresis)</li> </ul> Default setting = 0
434.0	---	reserve_1	Reserved	ARRAY [0 .. 1] (2)	---
436.0	4604	limit1_setpoint	Limit 1 setpoint	REAL (4)	Unit: If limit1_selection = Totalizer x: [DR2: totalizer_x_unit] All others: [%] of Max value of the selected value in limit1_selection (e. g. value 1 = 100 %) Range: -FLT_MAX ... +FLT_MAX Default setting = 0.1 (HMI: 10%)
440.0	4606	limit1_hysteresis	Limit 1 hysteresis	REAL (4)	Unit: If limit1_selection = Totalizer x: [DR2: totalizer_x_unit] All others: [%] of Max value of the selected value in limit1_selection (e.g. value 1 = 100 %) Range: -FLT_MAX ... +FLT_MAX Default setting = 0.05 (HMI: 5%)



## C.11 DR12 Limit default settings (R/W)

Offset in DB_FLOW_PARA	MODBUS addr	Parameter	Label	Data type (Number of bytes)	Value range and description
432.0		Limit		STRUCT	
444.0	4700	limit2_selection	Limit 2 selection	BYTE (1)	<ul style="list-style-type: none"> <li>• 0 = Off</li> <li>• 1 = Mass flow</li> <li>• 2 = Fraction A</li> <li>• 3 = Fraction B</li> <li>• 4 = Volume flow</li> <li>• 5 = Sensor temperature</li> <li>• 6 = Density</li> <li>• 7 = Totalizer 1</li> <li>• 8 = Totalizer 2</li> <li>• 9 = % Fraction A</li> </ul> Default setting = 0
445.0	4702	limit2_direction	Limit 2 direction	BYTE (1)	<ul style="list-style-type: none"> <li>• 0 = Low limit (limit status coming at setpoint, going at setpoint - hysteresis)</li> <li>• 1 = High limit (limit status coming at setpoint, going at setpoint + hysteresis)</li> </ul> Default setting = 0
446.0	---	reserve_2	Reserved	ARRAY [0 .. 1] (2)	---
448.0	4704	limit2_setpoint	Limit 2 setpoint	REAL (4)	Unit: If limit2_selection = Totalizer x: [DR2: totalizer_x_unit] All others: [%] of Max value of the selected value in limit2_selection (e. g value 1 = 100 %) Range: -FLT_MAX ... +FLT_MAX Default setting = 0.1 (HMI: 10%)
452.0	4706	limit2_hysteresis	Limit 2 hysteresis	REAL (4)	Unit: If limit2_selection = Totalizer x: [DR2: totalizer_x_unit] All others: [%] of Max value of the selected value in limit2_selection (e.g. value 1 = 100 %) Range: -FLT_MAX ... +FLT_MAX Default setting = 0.05 (HMI: 5%)

Data records

C.11 DR12 Limit default settings (R/W)

Offset in DB_FLOW_PARA	MODBUS addr	Parameter	Label	Data type (Number of bytes)	Value range and description
432.0		Limit		STRUCT	
456.0	4800	Limit3_selection	Limit 3 selection	BYTE (1)	<ul style="list-style-type: none"> <li>• 0 = Off</li> <li>• 1 = Mass flow</li> <li>• 2 = Fraction A</li> <li>• 3 = Fraction B</li> <li>• 4 = Volume flow</li> <li>• 5 = Sensor temperature</li> <li>• 6 = Density</li> <li>• 7 = Totalizer 1</li> <li>• 8 = Totalizer 2</li> <li>• 9 = % Fraction A</li> </ul> Default setting = 0
457.0	4802	limit3_direction	Limit 3 direction	BYTE (1)	<ul style="list-style-type: none"> <li>• 0 = Low limit (limit status coming at setpoint, going at setpoint - hysteresis)</li> <li>• 1 = High limit (limit status coming at setpoint, going at setpoint + hysteresis)</li> </ul> Default setting = 0
458.0	---	reserve_3	Reserved	ARRAY [0 .. 1] (2)	---
460.0	4804	limit3_setpoint	Limit 3 setpoint	REAL (4)	Unit: If limit3_selection = Totalizer x: [DR2: totalizer_x_unit] All others: [%] of Max value of the selected value in limit3_selection (e.g. value 1 = 100 %) Range: -FLT_MAX ... +FLT_MAX Default setting = 0.1 (HMI: 10%)
464.0	4806	limit3_hysteresis	Limit 3 hysteresis	REAL (4)	Unit: If limit1_selection = Totalizer x: [DR2: totalizer_x_unit] All others: [%] of Max value of the selected value in limit3_selection (e.g. value 1 = 100 %) Range: -FLT_MAX ... +FLT_MAX Default setting = 0.05 (HMI: 5%)

Offset in DB_FLOW_PARA	MODBUS addr	Parameter	Label	Data type (Number of bytes)	Value range and description
432.0		Limit		STRUCT	
468.0	4900	limit4_selection	Limit 4 selection	BYTE (1)	<ul style="list-style-type: none"> <li>• 0 = Off</li> <li>• 1 = Mass flow</li> <li>• 2 = Fraction A flow</li> <li>• 3 = Fraction B flow</li> <li>• 4 = Volume flow</li> <li>• 5 = Sensor temperature</li> <li>• 6 = Density</li> <li>• 7 = Totalizer 1</li> <li>• 8 = Totalizer 2</li> <li>• 9 = % Fraction A</li> </ul> Default setting = 0
469.0	4902	limit4_direction	Limit 4 direction	BYTE (1)	<ul style="list-style-type: none"> <li>• 0 = Low limit (limit status coming at setpoint, going at setpoint - hysteresis)</li> <li>• 1 = High limit (limit status coming at setpoint, going at setpoint + hysteresis)</li> </ul> Default setting = 0
470.0	---	reserve_4	Reserved	ARRAY [0 .. 1] (2)	---
472.0	4904	limit4_setpoint	Limit 4 setpoint	REAL (4)	Unit: If limit4_selection = Totalizer x: [DR2: totalizer_x_unit] All others: [%] of Max value of the selected value in limit4_selection (e.g. value 1 = 100 %) Range: -FLT_MAX ... +FLT_MAX Default setting = 0.1 (HMI: 10%)
476.0	4906	limit4_hysteresis	Limit 3 hysteresis	REAL (4)	Unit: If limit4_selection = Totalizer x: [DR2: totalizer_x_unit] All others: [%] of Max value of the selected value in limit4_selection (e.g. value 1 = 100 %) Range: -FLT_MAX ... +FLT_MAX Default setting = 0.05 (HMI: 5%)

**See also**

Limit value monitoring (Page 121)

## C.12 DR30 Process values (R)

Table C-13 Process values (R)

Offset in DB_FLOW_PARA	MODBUS addr	Parameter	Label	Data type (Number of bytes)	Value range and description
480.0	4000	system_status	System status	DWORD (4)	32 bit system status (see table "System status information" (Page 162))
484.0	3000	massflow	Massflow	REAL (4)	Unit: DR2: massflow_unit Range: 0 ... 27 kg/s
488.0	3002	Volumeflow	Volumeflow	REAL (4)	Unit: DR2: volumeflow_unit Range: 0 ... 109 m <sup>3</sup> /s
492.0	3004	density	Density	REAL (4)	Unit: DR2: density_unit Range: 0 ... 30 kg/m <sup>3</sup>
496.0	3006	sensor_temperature	Sensor temperature	REAL (4)	Unit: DR2: temperature_unit Range: 0 ... 2 °C
500.0	3008	fraction_A_flow	Fraction A flow	REAL (4)	Unit: DR2: fraction_A_unit Range: 0 ... 27 kg/s or 109 m <sup>3</sup> /s
504.0	3010	fraction_B_flow	Fraction B flow	REAL (4)	Unit: DR2: fraction_B_unit Range: 0 ... 27 kg/s or 109 m <sup>3</sup> /s
508.0	3012	percent_fraction_A	Fraction A percent	REAL (4)	Unit: %
512.0	3022	totalizer_1	Totalizer 1	REAL (4)	Unit: DR2: totalizer1_unit Range: 0 ... 8 kg or 21 m <sup>3</sup>
516.0	3024	totalizer_2_batch	Totalizer 2	REAL (4)	Unit: DR2: totalizer2_unit Range: 0 ... 8 kg or 21 m <sup>3</sup>

## C.13 DR31 Service information (R)

Table C-14 Service information (R)

Offset in DB_FLOW_PARA	MODBUS addr	Parameter	Label	Data type (Number of bytes)	Value range and description
520.0	4012	date_and_time	Date and time	DATE_AND_TIME (8)	Module date and time: day.month.year hour:minute:second millisecond day of the week Default setting = 01.01.01/ 00:00:00 / 000 Mo
528.0	2700	operating_time_total	Total operating time	DWORD (4)	Counter indicating the total time the module has been under power Operating time [h] in steps of 1 hour Range: 0 ... 136 years

Offset in DB_FLOW_PARAMETER_A	MODBUS addr	Parameter	Label	Data type (Number of bytes)	Value range and description
532.0	4002	operating_time_powerup	Operating time since power-up	DWORD (4)	Counter indicating the time since present power-up Operating time [h] in steps of 1 hour 0 ... 136 years
536.0	2756	driver_signal	Driver signal	REAL (4)	Current equivalent output to driver coil
540.0	2758	pickup_1_amplitude	Pickup 1 amplitude	REAL (4)	Pickup amplitude [V]
544.0	2760	pickup_2_amplitude	Pickup 2 amplitude	REAL (4)	Pickup amplitude [V]
548.0	2762	sensor_frequency	Sensor frequency	REAL (4)	
552.0	5500	transmitter_temperature	Transmitter temperature	REAL (4)	Transmitter temperature inside the housing <ul style="list-style-type: none"> <li>• Min: -40</li> <li>• Max: +80°C</li> </ul>
556.0	5200	sensorprom_installed	SENSORPROM installed	BYTE (1)	SENSORPROM installation status (mounted): <ul style="list-style-type: none"> <li>• 0 = No</li> <li>• 1 = Yes</li> </ul> Default setting = 1
557.0	---	reserve_1	Reserved	BYTE (1)	---
558.0	---	reserve_2	Reserved	ARRAY [0 .. 1] (2)	---
560.0	5502	zero_offset_value	Zero offset value	REAL (4)	Zero offset value after a valid zero adjust or after a CMD_ZERO_OFFSET_VALUE_PRESET Unit: DR: massflow_unit Range: DR3: massflow_min ... DR3: massflow_max
564.0	3211	zero_adjust_progress	Zero adjust progress	REAL (4)	0 ... 100% as factor (-> 1.0 = 100%)
568.0	2036	zero_sigma	Zero sigma	REAL (4)	Unit: DR2: massflow_unit Range: DR3: massflow_min ... DR3: massflow_max
572.0	2249	batch_cycle_counter	Batch_cycle_counter	DWORD (4)	Accumulated number of started batches

## C.14 DR32-34 Transmitter, sensor and customer data (R)

Table C-15 Transmitter data (R)

Offset in DB_FLOW_PARA	MODBUS addr	Parameter	Label	Data type (Number of bytes)	Value range and description
576.0		<b>Module firmware</b>		<b>STRUCT</b>	
576.0	5100	fw_code_crc32	Firmware checksum	DWORD (4)	CRC32 checksum of the code Default setting = 0
580.0	5102	fw_code_length	Firmware size	DWORD (4)	No of bytes of the code Default setting = 0
584.0	5104	fw_code_name	Firmware code name	STRING (20)	Name of the code: e.g.: "SIFLOW_FC_V1-0-0.bin"
606.0	5114	fw_compilation_date	Firmware compilation date	STRING (12)	Compilation date: e.g. 01.01.2003
620.0	5120	fw_compilation_time	Firmware compilation time	STRING (10)	Compilation time: e.g. 12:30.59
632.0	2530	fw_version	Firmware version	STRING (10)	Version of the application code: Vxx.yy.zz (ASCII) Byte 0 version letter: Before release for production A ... U = version in development After release for production V = Standard version for production W ... Z = Special customer versions Byte 1+2 xx 0 ... 99 Main function release Byte 4+5 yy 0 ... 99 Subfunction or data change release Byte 7+8 zz 0 ... 99 Error removal release
644.0	5125	fw_licence_control	Firmware licence control	BYTE (4)	
648.0	5128	bootsystem_version	Boot system version	STRING (10)	Version of the boot system: e.g. 0001 (info from boot sector) Default setting = 0
660.0	5127/605	transmitter_hw_ver	Hardware version	WORD (2)	Version of the hardware (ES with CADIM)
662.0	2500/613	transmitter_name	Transmitter name	STRING (20)	Module name
684.0	2510	transmitter_mlfb	Transmitter MLFB	STRING (20)	MLFB of the transmitter <ul style="list-style-type: none"> <li>• 7ME4 120-2DH20-0EA0 -&gt; non-Ex</li> <li>• 7ME4 120-2DH21-0EA0 -&gt; Ex</li> </ul>
706.0	2520	transmitter_serial_number	Transmitter serial number	STRING (20)	Serial number of the module
728.0	---	reserve_1	Reserved	ARRAY [0 .. 1] (2)	---

Table C-16 Sensor data (R)

Offset in DB_FLOW_PARA	MODBUS addr	Parameter	Label	Data type	Value range and description
<b>730.0</b>		<b>Sensor</b>		<b>STRUCT</b>	
730.0	2540	sensor_name	Sensor name	STRING (20)	Name of the sensor type (e.g. "MASS2100")
752.0	2550	sensor_mlfb	Sensor MLFB	STRING (20)	MLFB of the sensor
774.0	2560	sens_serial_number	Sensor serial number	STRING (20)	Serial number of the sensor
796.0	2570	sensor_pipe_diameter_text	Sensor pipe diameter	STRING (20)	Diameter of the sensor pipe
818.0	5202	fraction_calibration_X0	Fraction calibration X0	REAL (4)	Fraction calibration constant X0 (intercept) Range: -FLT_MAX ... +FLT_MAX Default setting = 1
822.0	5204	fraction_calibration_X1	Fraction calibration X1	REAL (4)	Fraction calibration constant X1 Range: -FLT_MAX ... +FLT_MAX Default setting = 0
826.0	5206	fraction_calibration_X2	Fraction calibration X2	REAL (4)	Fraction calibration constant X2 Range: -FLT_MAX ... +FLT_MAX Default setting = 0
830.0	5208	fraction_calibration_X3	Fraction calibration X3	REAL (4)	Fraction calibration constant X3
834.0	5210	fraction_calibration_X4	Fraction calibration X4	REAL (4)	Fraction calibration constant X4 Range: -FLT_MAX ... +FLT_MAX Default setting = 0
838.0	5212	fraction_calibration_X5	Fraction calibration X5	REAL (4)	Fraction calibration constant X5 Range: -FLT_MAX ... +FLT_MAX Default setting = 0
842.0	5214	fraction_calibration_X6	Fraction calibration X6	REAL (4)	Fraction calibration constant X6 Range: -FLT_MAX ... +FLT_MAX Default setting = 0
846.0	5216	fraction_calibration_X7	Fraction calibration X7	REAL (4)	Fraction calibration constant X7 Range: -FLT_MAX ... +FLT_MAX Default setting = 0
850.0	5218	fraction_calibration_X8	Fraction calibration X8	REAL (4)	Fraction calibration constant X8
854.0	5220	fraction_calibration_X9	Fraction calibration X9	REAL (4)	Fraction calibration constant X9 Range: -FLT_MAX ... +FLT_MAX Default setting = 0
858.0	5222	fraction_calibration_X10	Fraction calibration X10	REAL (4)	Fraction calibration constant X10 Range: -FLT_MAX ... +FLT_MAX Default setting = 0

C.15 DR35-36 MODBUS slave identification data and service information (R)

Offset in DB_FLOW_PARA	MODBUS addr	Parameter	Label	Data type	Value range and description
<b>730.0</b>		<b>Sensor</b>		<b>STRUCT</b>	
862.0	5224	fraction_calibration_X11	Fraction calibration X11	REAL (4)	Fraction calibration constant X11 Range: -FLT_MAX ... +FLT_MAX Default setting = 0
866.0	5226	fraction_a_text	Fraction A text	STRING (16)	
884.0	5232	fraction_b_text	Fraction B text	STRING (16)	
902.0	5240	fraction_value_selection	Fraction selection	BYTE (1)	<ul style="list-style-type: none"> <li>• 0= Massflow</li> <li>• 1= Volumeflow</li> </ul> Default setting = 0
903.0	---	reserve_1	Reserved	BYTE (1)	---
904.0	---	reserve_2	Reserved	ARRAY [0 .. 1] (2)	---

Table C-17 Customer data (R)

Offset in DB_FLOW_PARA	MODBUS addr	Parameter	Data type	Value range and description
<b>906.0</b>		<b>Customer</b>	<b>STRUCT</b>	
906.0	2580	customer_code_number	STRING (20)	Customer code number
928.0	---	reserve_1	ARRAY [0 .. 1] (2)	---

C.15 DR35-36 MODBUS slave identification data and service information (R)

Table C-18 Data record 35 (DR35) (R)

Offset in DB_FLOW_PARA	MODBUS addr.	Parameter	Label.	Data type (Number of BYTE (1)s)	Value range and description
930.0	600	manufacturer_id	Manufacturer ID	BYTE (1)	Default setting = 0x2A (= SIEMENS)
931.0	602	product_code	Product code	BYTE (1)	Default setting = 26 = SIFLOW FC070
932.0	603	capability_bits_1	Capability bits 1	BYTE (1)	Default setting = 0 (= 0x03)
933.0	604	capability_bits_2	Capability bits 2	BYTE (1)	Default setting = 1 (= 0xFF)



## C.15 DR35-36 MODBUS slave identification data and service information (R)

Offset in DB_F LOW_PAR A	MODBUS addr.	Parameter	Label.	Data type (Number of BYTE (1)s)	Value range and description
934.0	605	capability_bits_3	Capability bits 3	BYTE (1)	Default setting = 2 (= 0x01)
935.0	---	reserve_1	Reserved	BYTE (1)	---
936.0	607	manufacturer_name	Manufacturer name	STRING (12)	Default setting = SIEMENS AG

Table C-19 Data record 36 (DR36) (R)

Offset in DB_FL OW_PA RA	MODBUS addr.	Parameter	Label	Data type Number of bytes)	Value range and description
950.0	528	device_addresses	MODBUS device address	BYTE (1)	1 ... 247 (set by DIP switch or DR0-> device_address if DIP switch=0) Default setting = 1
951.0	---	reserve_1	Reserved	BYTE (3)	---
954.0	507	inter_frame_space_μs	Interframe space	DWORD (4)	Calculated from DR7->modbus_interframe_space
958.0	514	baudrate_hz	Baud rate	DWORD (4)	Calculated from DR7->modbus_baudrate
962.0	500	number_of_parity_errors	Number of parity errors	WORD (2)	
964.0	501	number_of_framing_errors	Number of framing errors	WORD (2)	
966.0	503	number_of_crc_errors	Number of CRC errors	WORD (2)	
968.0	504	number_of_ok_messages_received	Number of OK messages	WORD (2)	OK messages received
970.0	680	last_coil_error_addr	Last Coil Error	WORD (2)	CoilAddr
972.0	681	last_coil_error_no	Last coil error	WORD (2)	Error number
974.0	682	last_holdreg_error_addr	Last HoldReg Error	WORD (2)	HoldReg Addr
976.0	683	last_holdreg_error_no	Last hold register error	WORD (2)	Error number
978.0	3201	error_pending_1	Pending error 1	BYTE (1)	Number of oldest error
979.0	3202	error_pending_2	Pending error 2	BYTE (1)	

C.16 DR37 CT values (R)

Offset in DB_FLOW_PARAMETER	MODBUS addr.	Parameter	Label	Data type Number of bytes)	Value range and description
980.0	3203	error_pending_3	Pending error 3	BYTE (1)	
981.0	3204	error_pending_4	Pending error 4	BYTE (1)	
982.0	3205	error_pending_5	Pending error 5	BYTE (1)	
983.0	3206	error_pending_6	Pending error 6	BYTE (1)	
984.0	3207	error_pending_7	Pending error 7	BYTE (1)	
985.0	3208	error_pending_8	Pending error 8	BYTE (1)	
986.0	3209	error_pending_9	Pending error 9	BYTE (1)	Number of newest error
987.0	601	run_indicator	Run indicator	BYTE (1)	0 = OFF 0xFF = Running
988.0	---	reserve_2	Reserved	BYTE (2)	---

C.16 DR37 CT values (R)

The values of data record 37 are encrypted.

Table C-20 CT values (R)

Offset in DB_FLOW_PARAMETER	MODBUS addr	Parameter	Label	Data type (Number of bytes)	Value range and description
990	-	crypto_crc	Checksum CRC16 of byte 2 to 31	WORD (2)	
992	.	Status	Bit 0 ... 5: refresh counter (0 ... 63) Bit 6 ... 15: Status	WORD (2)	
994	-	Random	Random number for verification	WORD (2)	
996	-	Control	Control number for verification	WORD (2)	
998	-	process_value_1	First calibrated process value	REAL (4)	

Offset in DB_FLOW_PARA	MODBUS addr	Parameter	Label	Data type (Number of bytes)	Value range and description
1002	-	process_value_2	Second calibrated process value	REAL (4)	
1006	-	pv_1_unit_ID	Unit ID for first CT value	WORD (2)	
1008	-	pv_2_unit_ID	Unit ID for second Ct value	WORD (2)	
1010	-	Reserve	Reserve	BYTE (2)	
1012	-	serial_number	Module-specific serial number	BYTE (10)	

## C.17 DR39 CT parameters (R/W)

Table C-21 CT parameters (R/W)

Offset in DB_FLOW_PARA	MODBUS addr	Parameter	Label	Data type (Number of bytes)	Value range and description
1022	5504	ocx_version_type	Checksum CRC16 of byte 2 to 31	STRING (3)	
1025	-	reserve39_1	Bit 0 ... 5: refresh counter (0 ... 63) Bit 6 ... 15: Status	BYTE (1)	
1026	5505	Process_value_1_ID	Random number for verification	BYTE (1)	Selection for first process data 0 = volume flow 1 = mass flow 2 = fraction A flow 3 = fraction B flow 4 = density 5 = totalizer 1 6 = totalizer 2 7 = No Process Value Select 255 = CT mode disabled

C.18 DR181 Diagnostics buffer (R)

Offset in DB_FLOW_PARA	MODBUS S addr	Parameter	Label	Data type (Number of bytes)	Value range and description
1027	5506	Process_value_2_ID	Control number for verification	BYTE (1)	Selector for second process data 0 = volume flow 1 = mass flow 2 = fraction A flow 3 = fraction B flow 4 = density 5 = totalizer 1 6 = totalizer 2 7 = No Process Value Select 255 = CT mode disabled
1028	5507	ocx_main-nr	First calibrated process value	WORD (2)	
1030	5508	Ocx_sub-nr	Second calibrated process value	WORD (2)	

## C.18 DR181 Diagnostics buffer (R)

Table C-22 Diagnostics buffer (DR 181)

Offset in DB_FLOW_PARA	MODBUS addr.	Parameter	Label	Data type (Number of bytes)	Value range and description
	---	szl_id	SZL-ID	WORD (2)	(SZL-TL 00A0) Default setting = 0x00A0
	---	last_index	Last index entry	WORD (2)	References to the last entry in dia_elem_info[x], see table below. Range: 0 ... 8 Index = 0: 1. entry ( = dia_elem_info[0] ) Index = 1: 2. entry ( = dia_elem_info[1] ), etc.
	---	dia_elem_len	Diagnostics info length	WORD (2)	Length of one diagnostics info Default setting = 20
	---	dia_elem_count	Diagnostics info counter	WORD (2)	Number of entries in dia_elem_info[x]; Range: 0 ... 9 0 = no entry
	5400	dia_elem_info	Diagnostics info	BYTE [9] [20] (180)	Diagnostics info: The last 9 not filtered (DR3.error_level) diagnostics infos, see table below

Table C-23 dia\_elem\_info

MODBUS addr.	Parameter	Label	Data type (Number of bytes)	Value range and description
---	de_class	Error class	WORD (2)	Detailed error event status and class: 0xF(K)60 K: <ul style="list-style-type: none"> <li>• Bit 0: C / G (C = 1 / G = 0) error status: incoming or outgoing</li> <li>• Bit 1: 0</li> <li>• Bit 2: internal error (S7-class)</li> <li>• Bit 3: external error (S7 class)</li> </ul> Default setting = 0
---	de_number	Error number	WORD (2)	Detailed error event number (number = 0x1000 ... 0x12FF), see tables "Sensor errors and process errors (Page 152)" and "Handling errors" for individual error event No.: <ul style="list-style-type: none"> <li>• 0x10** PE / SE</li> <li>• 0x11** HE</li> </ul> Default setting = 0
---	info4	Error source	BYTE (1)	Source of the error <ul style="list-style-type: none"> <li>• 1 = internal (source is module itself or SENSORPROM or ConverterPROM)</li> <li>• 2 = SIMATIC (P-Bus / command or parameter)</li> <li>• 3 = MODBUS (RS232 or RS485 / command or parameter)</li> <li>• 4 = Digital input (command)</li> <li>• 5 = simulation</li> <li>• 6 ... 127 reserved</li> </ul> Default setting = 0
---	info5	Error type	BYTE (1)	SIFLOW error type; see table SIFLOW FC070 error types (Page 151) Default setting = 0
---	Info1	NAMUR error class	WORD (2)	See table NAMUR VDI 2650 classes (Page 151) Default setting = 0
---	Info2		WORD (2)	Additional error code Default setting = 0
---	Info3		WORD (2)	Free Default setting = 0
---	Date_and_time	Date and time	DATE_AND_TIME (8)	Time stamp Default setting = 0



## CT parameters

### D.1 Redundancy pulse output

90°/180°

Parameter name (PDM)	Parameter name (SIFLOW)	Comment
Operating Conditions \ Correction Factor	DR9 Sensor properties\ correction_factor	With this factor you are able to make a flow correction in % on the flowmeter. From factory the correction factor is set to 1,0000. Flow rate (kg/h) = Correction factor x flow rate (kg/h). If you want to change the flow on the flowmeter with +0.5 %, you have to change the correction factor to 1,005. After the change the flowmeter will show a flow rate 0.5 % higher than before on all flow-related values
Digital output \ Digital output	DR5 Digital output\ dig_out_func	Off: Output 1 and 2 are deactivated. Redundancy Pulse 90° / 180°
Digital output \ Measurement Function	DR5 Digital output\ pulse_value_selection	Mass (flow) Fraction A Fraction B Volume (flow)
Digital output \ Unit	DR2 Units of the process values\ pulse_amount_unit	Selects the unit of the mass/pulse or volume/pulse
Digital output \ Volume/pulse	DR5 Digital output \ pulse_mass_or_vol_amnt	Specifies the mass / volume amount for each pulse
Digital output \ Pulse Output Direction	DR5 Digital output \ pulse_direction	Unidirectional: The output will only give pulses if the measured flow is positive. Bidirectional: The output will always give pulses - whatever the direction of the measured flow is
Digital output \ Pulse Width	DR5 Digital output \ pulse_width	Pulse width of the digital output. Can be set according to the specification of the pulse counter
Digital output \ Pulse Polarity	DR5 Digital output \ pulse_output_polarity	State of the passive Output switch: Normally open if no pulse= no current, voltage low. Normally closed if no pulse= current, voltage high

*CT parameters*

*D.1 Redundancy pulse output*

<b>Parameter name (PDM)</b>	<b>Parameter name (SIFLOW)</b>	<b>Comment</b>
Digital output \ SF reaction	DR5 Digital output \ dig_out_sf_reaction	Digital Output reaction at System fault (SF): 0 = no special reaction at SF 1 = Set outputs to off 2 = Set outputs to on
OCX \ Process Value 1 ID	DR39 CT parameters \ Process_value_1_ID	This value must be set to: No Process Value select
OCX \ Process Value 2 ID	DR39 CT parameters \ Process_value_2_ID	This value must be set to: No Process Value select



## D.2 Redundancy frequency output

90°/180°

Parameter name (PDM)	Parameter name (SIFLOW)	Comment
Operating Conditions \ Correction Factor	DR9 Sensor properties\ correction_factor	With this factor you are able to make a flow correction in % on the flowmeter. From factory the correction factor is set to 1.0000. Flow rate (kg/h) = Correction factor x flow rate (kg/h). If you want to change the flow on the flowmeter with +0,5 %, you have to change the correction factor to 1.005. After the change the flowmeter will show a flow rate 0,5 % higher as before, on all flow-related values
Digital output \ Digital output	DR5 Digital output\ dig_out_func	Off: Output 1 and 2 are deactivated. Redundancy Frequency 90 ° / 180°
Digital output \ Measurement Function	DR5 Digital output\ frequency_val_sel	Mass (flow) Volume (flow) Temperature Density Fraction A (Flow) Fraction B (Flow) Fraction A (%)
Digital output \ Frequency Output Direction	DR5 Digital output \ frequency_direction	Unidirectional: The output will only give frequency if the measured flow is positive. Bidirectional: The output will give frequency whatever the direction of the measured flow is
Digital output \ Frequency Output Fmax	frequency_max	Frequency Fmax 10 kHz 5 kHz 1 kHz 500 Hz
Digital output \ Frequency output Timeconstant	DR5 Digital output \ frequency_time_const	For frequency outputs used in controlling systems it is sometimes necessary to increase the time constant to get a more stable system - or to decrease the time constant to get a faster and more precise measuring system on the output signals. The time constant Tau can be set to 0 ... 60 sec., please see the settings. The output signal is damped accordingly to following formula: $A = K(1 - e^{-t/\tau})$ ; where Tau = time constant 1 Tau = 0,63 K 5 Tau = 0,993 K

*CT parameters*

*D.2 Redundancy frequency output*

<b>Parameter name (PDM)</b>	<b>Parameter name (SIFLOW)</b>	<b>Comment</b>
Digital output \ SF reaction	DR5 Digital output \ dig_out_sf_reaction	Digital Output reaction at System fault (SF): 0 = no special reaction at SF 1 = Set outputs to off 2 = Set outputs to on
OCX \ Process Value 1 ID	DR39 CT parameters \ Process_value_1_ID	This value must be set to: No Process Value select
OCX \ Process Value 2 ID	DR39 CT parameters \ Process_value_2_ID	This value must be set to: No Process Value select

## D.3 OCX

DR39

Parameter name (PDM)	Parameter name (SIFLOW)	Comment
OXC \ SW Version Type	DR39 CT parameters \ ocx_version_type	This value must be set to: "V"
OXC \ Process value 1	DR39 CT parameters \ Process_value_1_ID	Selection for first process data: Volume flow Mass flow Fraction A flow Fraction B flow Density Totalizer 1 Totalizer 2 No Process Value Select CT mode disabled  Note: If not using process value 1, but using redundancy digital output, then select "No Process value Select"
OXC \ Process value 2	DR39 CT parameters \ Process_value_2_ID	Selection for first process data: Volume flow Mass flow Fraction A flow Fraction B flow Density Totalizer 1 Totalizer 2 No Process Value Select CT mode disabled  Note: If not using process value 2, but using redundancy digital output, then select "No Process value Select"
OCX \ Main Number	DR39 CT parameters \ ocx_main-nr	OCX version main number
OCX \ Sub Number	DR5 Digital output \ ocx_sub-nr	OCX version sub number



# ESD guidelines



Observe the ESD guidelines



<b>CAUTION</b>
<b>ESD protective measures</b>
When handling function modules and other components carrying this symbol, always observe the ESD protection directives ( <b>E</b> lectrostatically <b>S</b> ensitive <b>D</b> evelopments/).

- Never touch the function modules unless necessary work makes this unavoidable.
- When handling the function modules, use a conductive and grounded work surface.
- Wear a grounding bracelet.
- Never touch chip pins, component connections or circuit board conductors when handling the function modules.
- Never allow function modules or components to touch chargeable objects (plastics).
- Never place components or function modules in the vicinity of cathode ray tube units or television sets (minimum distance: 10 cm).
- Leave the function modules in their special packaging until you are ready to use them. Do not take the function modules out of their packaging or touch them when registering them and so on.
- Function modules may only be installed or removed when the power is off.
- This warning sign on Siemens products draws your attention to appropriate protective measures you need to take.



## Abbreviations

<b>CFC</b>	Continuous Function Chart for PCS7
<b>CiR</b>	Configuration in RUN
<b>DB</b>	Data block
<b>DR</b>	Data record
<b>EDD</b>	Electronic Device Description
<b>ES</b>	Engineering station, engineering system
<b>FB</b>	Function block
<b>FP</b>	Faceplates for PCS 7
<b>HE</b>	Handle error
<b>HMI</b>	Human-machine interface, operator control and monitoring

<b>OM</b>	Object manager
<b>OS</b>	Operator station
<b>PCS 7</b>	Process control software
<b>PDM</b>	Process Device Manager
<b>PE</b>	Process error
<b>PLC</b>	Programmable logic controller
<b>PS</b>	Power supply
<b>RTU</b>	Remote terminal unit
<b>SE</b>	Sensor error
<b>SF</b>	System failure
<b>SFC</b>	Sequential Function Chart for PCS7
<b>SIFLOW</b>	Siemens flowmeter



**SPH**

System development response specification

**UDT**

User-defined data type



# Glossary

## ASIC

Application-Specific Integrated Circuit is an integrated circuit (IC) customized for a particular use, rather than intended for general-purpose use.

## BRIX

Degrees Brix (symbol °Bx) is a measurement of the mass ratio of dissolved sugar to water in a liquid. A 25 °Bx solution is 25% (w/w), with 25 grams of sugar per 100 grams of solution.

## CAN

Controller Area Network. CAN is the leading serial bus system for embedded control. CAN is a mainstream network and was internationally standardized (ISO 11898–1) in 1993.

## CiR

As of firmware V3.1, the SIMATIC S7-400 has been equipped with the system property "Configuration in RUN". You can use "Configuration in RUN" to change the hardware configuration and to start it up rapidly and cost-effectively while a plant is running. CiR comprises the addition, removal and reparameterization of distributed slaves and modules on PROFIBUS DP and PROFIBUS PA without interrupting the current production process.

## Code block

A SIMATIC S7 code block contains elements of the STEP 7 user program. (In contrast to a data block: this only contains data.)

## Coriolis

The Coriolis effect is an apparent deflection of moving objects from a straight path when they are viewed from a rotating frame of reference. The effect is named after Gaspard-Gustave Coriolis, a French scientist who described it in 1835. The Coriolis effect is caused by the Coriolis force, which appears in the equation of motion of an object in a rotating frame of reference.

## Correction factor

With this factor you are able to make a flow correction in % on the flowmeter.

Flow rate (kg/h) = Correction factor x flow rate (kg/h).

If you want to change the flow on the flowmeter by +0.5 %, you have to change the correction factor to 1.005 in the device menu 'Sensor characteristics'. After the change, the flowmeter will show a flow rate 0.5 % higher than before for all flow-related values.

## Density parameter

The density parameter is a constant found under the density calibration. This constant is used to calculate the density of the fluid in the sensor.

- Density ( $\text{kg/m}^3$ ) =  $A + B (1 + \text{Density TC} \times \text{temp.}) * (1/(\text{fr})^2)$ .
- A = density parameter A ( $\text{kg/m}^3$ ).
- B = constant.
- Density TC = sensor's density temperature coefficient (%/DegC).
- fr. = the sensor's resonance freq. (Hz).

Standard sensors without density calibration have average values stored in the SENSORPROM

## DFT

The discrete Fourier transform (DFT) is one of the specific forms of Fourier analysis. As such, it transforms one function into another, which is called the frequency domain representation, or simply the DFT, of the original function (which is often a function in the time domain). The DFT evaluates enough frequency components to reconstruct the finite segment that was analyzed. The DFT is thus a transform for Fourier analysis of finite-domain discrete-time functions.

## Diagnostics buffer

The diagnostics buffer represents a buffered memory area in the CPU. It stores diagnostics events in the order of their occurrence. In STEP 7, you can select **Target system > Module status** to read the cause of an error from the diagnostics buffer.

## Diagnostics data

All diagnostics events are collected in the CPU and entered into the → Diagnostics buffer. An error OB is started if present.

## Diagnostics interrupt

Modules with diagnostics capability report system errors to the CPU by means of diagnostics interrupts. The CPU operating system calls the OB82 in the event of a diagnostics interrupt.

## EMC

Electromagnetic compatibility (EMC) is the branch of electrical sciences which studies the unintentional generation, propagation and reception of electromagnetic energy with reference to the unwanted effects (Electromagnetic Interference, or EMI) that such energy may induce. The goal of EMC is the correct operation, in the same electromagnetic environment, of different equipment which use electromagnetic phenomena, and the avoidance of any interference effects.

## Fraction

Fraction is defined as a part of a mixture. Mixtures consist of two components (A+B) which can be measured separately. If the flowmeter is ordered with fraction, e.g. °BRIX, the flowmeter is able to calculate the % concentration of sugar in a water (B) + sugar (A) mixture. In the factory, the fraction factor b is set to 1.0000.

Formula: % concentration = a + b x % concentration = the concentration of media e.g. in °BRIX

- a = fraction offset in %
- b = is a factor without dimension
- x = is the concentration in % or e.g. °BRIX

## Function block (FB)

According to IEC 1131-3, a function block (FB) is a → Code block with → Static data. An FB allows the user program to pass parameters. Function blocks are therefore suitable for programming frequently occurring complex functions, e.g. controls, mode selections.

## Function module (FM)

A function module (FM) is a module which offloads the CPU of S7 and M7 automation systems with respect to signal processing tasks which are time-critical or which require a large amount of memory. FMs normally use the internal communications bus for fast exchange of data with the CPU. Examples of FM applications: counting, positioning, control, weighing, measurement.

## HART

HART Communication is a bi-directional industrial field communication protocol used to communicate between intelligent field instruments and host systems. HART is the global standard for smart process instrumentation and the majority of smart field devices installed in plants worldwide are HART-enabled. HART technology is easy to use and very reliable

## IP

An IP (Ingress Protection) number is used to specify the environmental protection of enclosures around electronic equipment. These ratings are determined by specific tests. The IP number is composed of two numbers, the first referring to the protection against solid objects and the second against liquids. The higher the number, the better the protection. For example, in IP67 the first Number (6) means that the device is totally protected against dust, and the second (7) that it is protected against the effect of immersion between 15cm and 1m

## Modbus

Modbus is a serial communications protocol intended for use with programmable logic controllers (PLCs). Modbus allows for communication between many devices connected to the same network, for example a system that measures temperature and humidity and communicates the results to a computer. Modbus is often used to connect a supervisory computer with a remote terminal unit (RTU) in supervisory control and data acquisition systems.

### **Modbus master**

A Modbus device that can access data in one or more connected Modbus slave devices.

### **Modbus slave**

A Modbus device that can respond to requests from a single Modbus master.

### **NAMUR**

Normenarbeitsgemeinschaft für Meß- und Regeltechnik in der Chemischen Industrie (NAMUR). NAMUR is a group representing the interests of the chemical industry which creates standards for instrumentation and electrical devices used in industrial plants.

### **Organization block**

Organization blocks (OBs) form the interface between the CPU operating system and the user program. The sequence for executing the user program is specified in the organization blocks.

### **PED**

The Pressure Equipment Directive (97/23/EC) is the legislative framework on European level for equipment subject to a pressure hazard. It was adopted by the European Parliament and the European Council in May 1997 and has been obligatory throughout the European Union since May 2002.

### **Plato**

Plato is a measure of the weight of the solids dissolved in water. It is expressed in %.

### **Process interrupt**

A process interrupt (hardware) is triggered by a module because of a certain event in the process (upward or downward violation of a limit; module has completed the cyclic conversion of its channels).

The process interrupt is reported to the CPU. The assigned → Organization block is then processed according to the interrupt priority.

### **PROFIBUS**

PROFIBUS (Process Field Bus) is a vendor-independent, open bus system standardized in the German DIN 19 245. It is a standard for field bus communication in automation technology and should not be confused with the PROFINET standard for industrial Ethernet. PROFIBUS-PA (Process Automation) is one of three PROFIBUS variants that are compatible with each other. PROFIBUS-DP (Decentralized Periphery).

**RTU**

Remote terminal unit = standard Modbus transmission mode

**Safety Extra-Low Voltage (SELV)**

IEC 61140 defines a SELV system as "an electrical system in which the voltage cannot exceed ELV under normal conditions, and under single-fault conditions, including earth faults in other circuits".

**SENSORPROM**

All sensor related settings/data saved on an EPROM. SENSORPROM technology automatically configures the transmitter at start up providing calibration data, pipe size, sensor type, and output settings. The SENSORPROM automatically stores values or settings changed by users, and automatically re-programs any new transmitter without loss of accuracy.

**Turndown ratio**

'Turndown ratio' is a flow measurement term indicating the range a specific flowmeter, or meter type, is able to measure with acceptable accuracy. It is also known as rangeability. If a gas flow to be measured is expected to vary between 100,000 m<sup>3</sup> per day and 1,000,000 m<sup>3</sup> per day, the specific application has a turndown ratio of 10:1. Therefore the meter requires a turndown ratio of at least 10:1.

**USM**

USM II is a Communication Platform. The Siemens USM II concept enables fitting of add-on bus modules without loss of functionality:

1. All modules can be fitted as true "plug & play"
2. Module and transmitter are automatically configured through the SENSORPROM

**Zero point adjustment**

The zero point adjustment must be performed in order to achieve the highest measuring accuracy. In order to zero adjust the device, the flow must be completely stopped ('zero flow'). A manual zero point adjustment can be obtained through the menu in the transmitter.





# Index

## A

Assembly, (See Installation)  
Automation environment, 21

## B

Batch, 128  
  Commands, 130  
  Counter, 130  
  Lead constant, 129  
  Overrun, 129  
  Status, 130  
  Timeout, 129  
  Two stage, 131  
Batch mode, 187  
Bytes 0 and 1  
  of diagnostic data, 245

## C

Commissioning  
  Reading parameters into DB17 (S7), 85  
  Setting basic parameters (PDM), 78  
  System optimization (PDM), 79  
  System optimization (S7), 89  
  with PDM, 78  
  With PDM, 77  
Compliance, (See Safety)  
Contact person, 13  
Coriolis  
  Applications, 21  
  Measurement principle, 28  
Cross talk, 179  
Customer Support Hotline, 167

## D

Decontamination, 168  
Device  
  Identification, 12  
  Inspection, 11  
Diagnose  
  with SIMATIC PDM, 174  
Diagnostics  
  Data, 144

Diagnostics data  
  Reading out, 146  
Dosing, (See Batch)

## E

electrical connection  
  Examples, 45  
Electrical connection, 38  
  Assembling the module, 36  
  Color coding of sensor cable, 40, 43  
  Digital input, 47  
  Digital outputs, 47  
  Front connector (Ex), 42  
  Front connector (non ex), 39  
  Functionality test, 47  
  Partition, 35  
  Pin assignments, 40  
  Pin assignments (Ex), 42  
  Power supply, 47  
  Safety instructions, 35  
  Wiring (ex), 41  
  Wiring (non ex), 39  
Electrical Connection  
  Minimum thread length, 38  
Empty pipe detection, (See Monitor functions)  
Errors  
  Codes, 162  
  Data and operating, 156  
  Diagnostics data, 144  
  Message paths, 142  
  Message types, 141  
  NAMUR classes, 152  
  Process, 152  
  Sensor, 152  
  SIMATIC error classes, 151  
  Slave diagnostics, 164  
  System status, 162  
  Types, 151

## F

Features  
  Basic, 26  
Fraction, 134  
Frequency output, 186, 188  
Front connector (non ex), (See Electrical connection)  
Functionality, (See Features)

## H

- Hazardous area
  - Approvals, 16
  - Special conditions, 17
- Hotline, 167

## I

- Input
  - Digital, 132
- Installation
  - Assembly on the rail, 34
  - Ex module, 35
  - Ex-requirements, 19
  - Hardware, 29
  - Incorrect, 179
  - Module replacement, 29
  - PDM driver, 52
  - S7 HW update, 49
  - S7 SW, 49
  - Safety, 18
  - SENSORPROM, 30
  - Software, 49
- Internet
  - Contact person, 13, 168
  - Flowdocumentation, 13
  - Support, 168
- Intrinsically safe data, 16
- Items supplied, 11

## L

- LED check, 48
- LED display, 171
- Limits, 121
- Low flow cut-off, 179
- Low-flow cut-off, 117

## M

- Maintenance, 167
- Measurement error, 177
- Modbus
  - Factory settings, 55

## MODBUS

- Connection to, 45
- Connection to master over RS232, 46
- Service information, 140
- Slave address, 33
- Slave address switch, 33
- Module replacement, 29
- Monitor functions
  - Batch timeout and overrun, 129
  - Empty pipe detection, 117
- Monitoring functions
  - Limit values:Limit value monitoring, 121

## N

- Nameplate, 12
- Noise filter, 118

## O

- Output
  - Batch, 128
  - Batch, two stage, 131
  - Digital, 125
  - Freeze / Force, 132
  - Frequency, 127
  - Phase shift, 128
  - Pulse, 126

## P

- Partition, 35
- PDM
  - Commissioning, 77
  - Configuring in SIMATIC manager, 54
  - Driver installation, 52
  - Setting basic parameters, 78
  - System optimization, 79
- Plug connectors
  - Plug connectors, 38
- Programming
  - S7, 57
- Pulse output, 186, 189

## R

- Repair, 167
- Return procedures, 168

**S**

- S7
  - Data block, 59
- Safety, 15
  - Certifications and approvals, 18
  - Ex requirements, 19
  - Explosion protection information, 18
  - Extra Low Voltage, 18
- Safety instructions
  - Electrical connection, 35
- Scaling, 119
- SENSORPROM, 28, 29
- Service, 167, 168
- Shielding, 44
- Simulation, 122
  - Error, 124
  - Example, 123
  - Input, 124
  - Output, 124
  - Possible values, 123
- Step 7
  - Commissioning, 81
  - Demo software, 84
  - Function block, 58
  - HW Configuration, 58, 81
  - HW support package, 49
  - Programming, 57
  - Reading parameters into DB17, 85
  - Reading process values, 91
  - SW library, 49
- Support, 168
- System expansions, 15
- System status information, 162

**T**

- Theory of operation, 28
- Totalizer, 135
  - Reset / preset, 136
  - Values, 135
- Two stage batch, 187

**U**

- Unit Conversion, 120

**V**

- Vibrations, 179

**W**

- Write protection, 34
- Write protection switch, 33

**Z**

- Zero point adjustment, 116
- Zero point adjustment, 79, 89
  - Automatic, 115
  - Manual, 116
  - Step 7, 89
  - Via PDM, 79
- Zero point adjustment function, 115
- Zero sigma, (See Zero point adjustment:Zero sigma)