

SIEMENS

Operating Manual

SITRANS F C MASSFLO®

MASS flowmeters

Signal converter type MASS 6000



Order no.: FDK:521H0991

SFIDK.PS.028.M1.02 - A5E00253658



Contents

1.	Installation of sensor	2
2.	Installation of signal converter	3
2.1	Compact installation	3
2.2.1	Remote Installation	4
	At the sensor	4
2.2.2	Remote installation	5
	Wall mounting	5
	Compact IP 67 version	5
2.2.3	Remote installation	6
	Signal converter in 19" insert	6
3.	Technical data	7
3.1	Signal converter MASS 6000	7
4.	Electrical connection	8
4.1	Signal converter MASS 6000	8
4.2	Output characteristics MASS 6000	9
5.	Commissioning	10
5.1	Menu overview	10
5.2	Menu details	11
5.3	Outputs setting menu	12
6.	Service	14
6.1	List of error numbers	14
6.2	Trouble shooting MASS 6000	15

**Potential Hazards**

The mains protective earth wire must be connected to the PE \oplus terminal in accordance with the diagram.

1. Installation of sensor

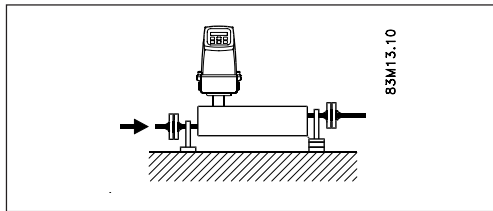
Horizontal mounting

Mount the sensor on a vibration-free wall or steel frame as shown.

Ensure that the sensor is not emptied of liquid (during normal operation) otherwise incorrect measurement will occur.

With low flow, horizontal mounting is recommended, as in this position air bubbles are easier to remove.

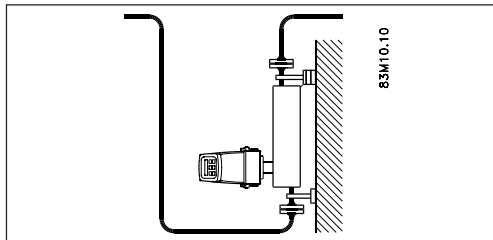
Vertical mounting

Locate the sensor low in the system in order to avoid an under-pressure in the sensor separating air/gas in the liquid.

If the liquid is volatile or contains solid particles, vertical mounting is not recommended.

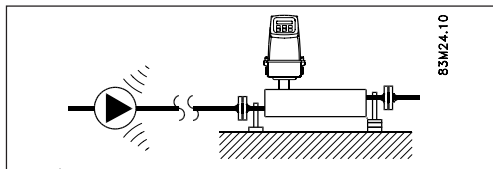
Vibration

Always locate the flowmeter as far away as possible from components that generate mechanical vibration in the piping.

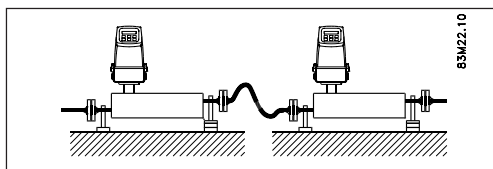
Cross talk

Cross talk between sensors mounted close to each other may disturb the measurement. To avoid cross talk never mount more than one meter on each frame and mount flexible hose connections between the sensors as shown.

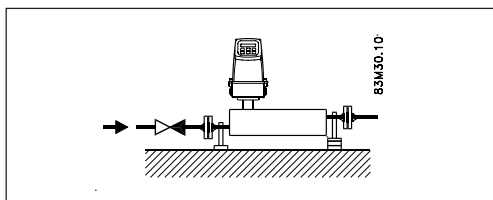
Zero-point adjustment

To facilitate zero-point adjustment, a valve with good shut-off should always be mounted in connection with the sensor as a proper zero-point setting is essential for a good accuracy.

2. Installation of signal converter

2.1 Compact installation

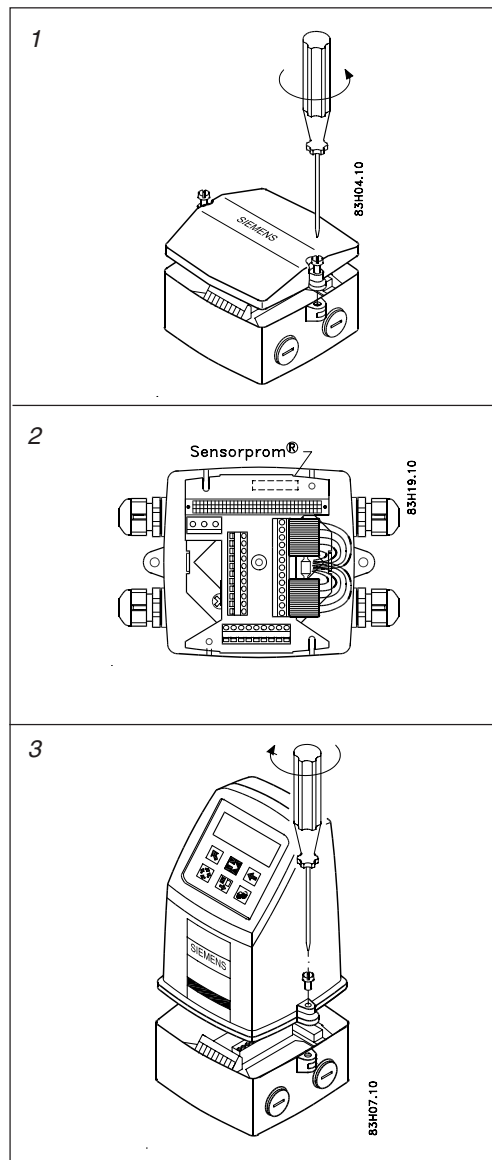
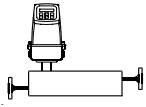

Remove and discard the terminal box lid of the sensor.

Fit the PG 13.5 cable glands for the supply and output cables.

Fit the supply and output cables respectively and tighten the cable glands to obtain optimum sealing.

Please see the wiring diagram for the "Electrical connections".

Mount the signal converter on the terminal box.

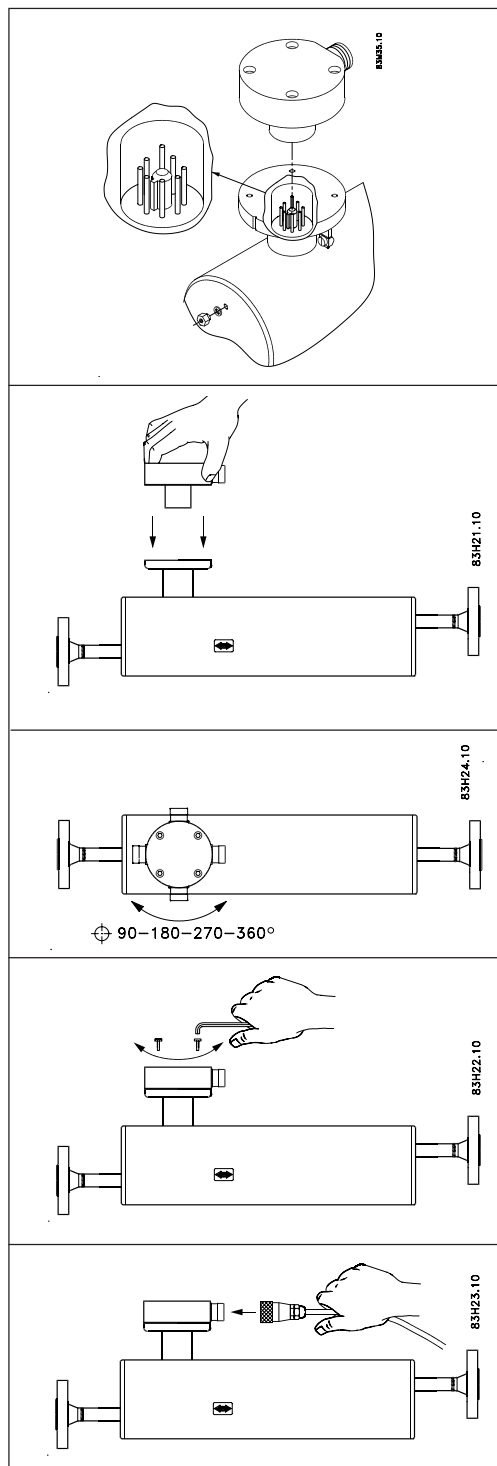
2.2.1 Remote Installation
At the sensor

Mount the adaptor on top of the sensor interface, if not already mounted.
When fitting the multiple plug, please make sure that it is correctly oriented (note the little tap).

The adaptor can be oriented in 4 directions.

Tighten the 4 screws with a 4 mm allen key to secure the adaptor.

Mount the multiple plug in the adaptor and tighten the glands on the plug to obtain optimum sealing.
Note the wire colours when connecting the MASS 6000. Refer to the diagram for electrical wiring, see page 8.

2.2.2 Remote installation Wall mounting Compact IP 67 version

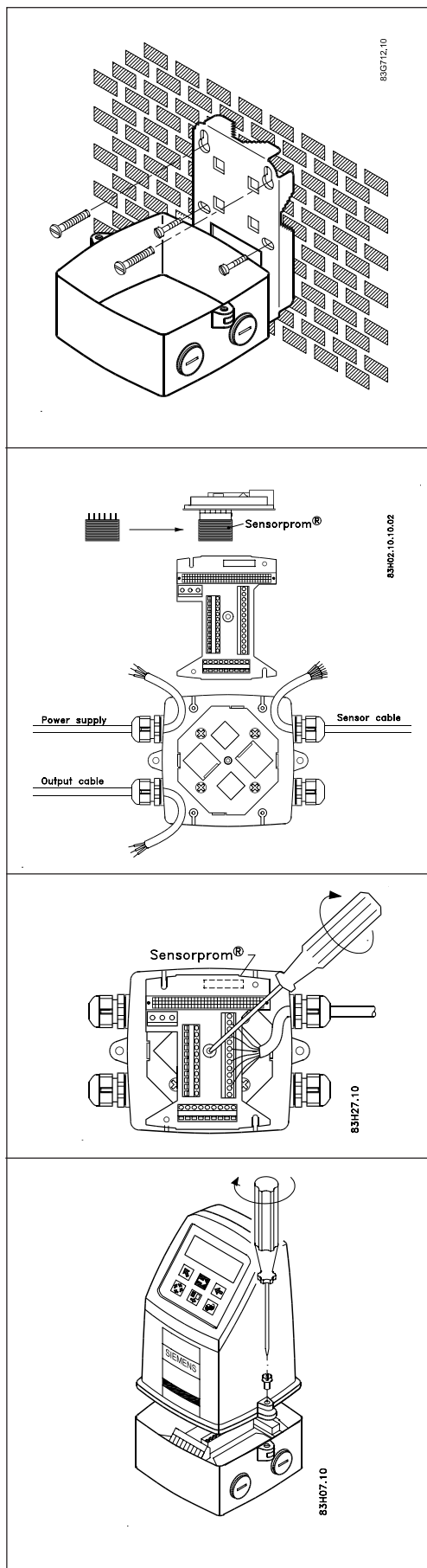

Mount the wallbracket on a wall, pipe or in the back of a panel.

Take the SENSORPROM® memory unit from the sensor. Mount the SENSORPROM® unit in the wall mounting unit as shown. The text on the SENSORPROM® unit **must** turn towards the wall bracket.

Mount the connection plate in the terminal box. Tighten the earthing screw in the centre of the connection box properly.

Fit the sensor, supply and output cables respectively and tighten the cable glands to obtain optimum sealing. Please see the wiring diagram for the "Electrical connections".

Mount the signal converter on the terminal box.

2.2.3 Remote installation Signal converter in 19" insert

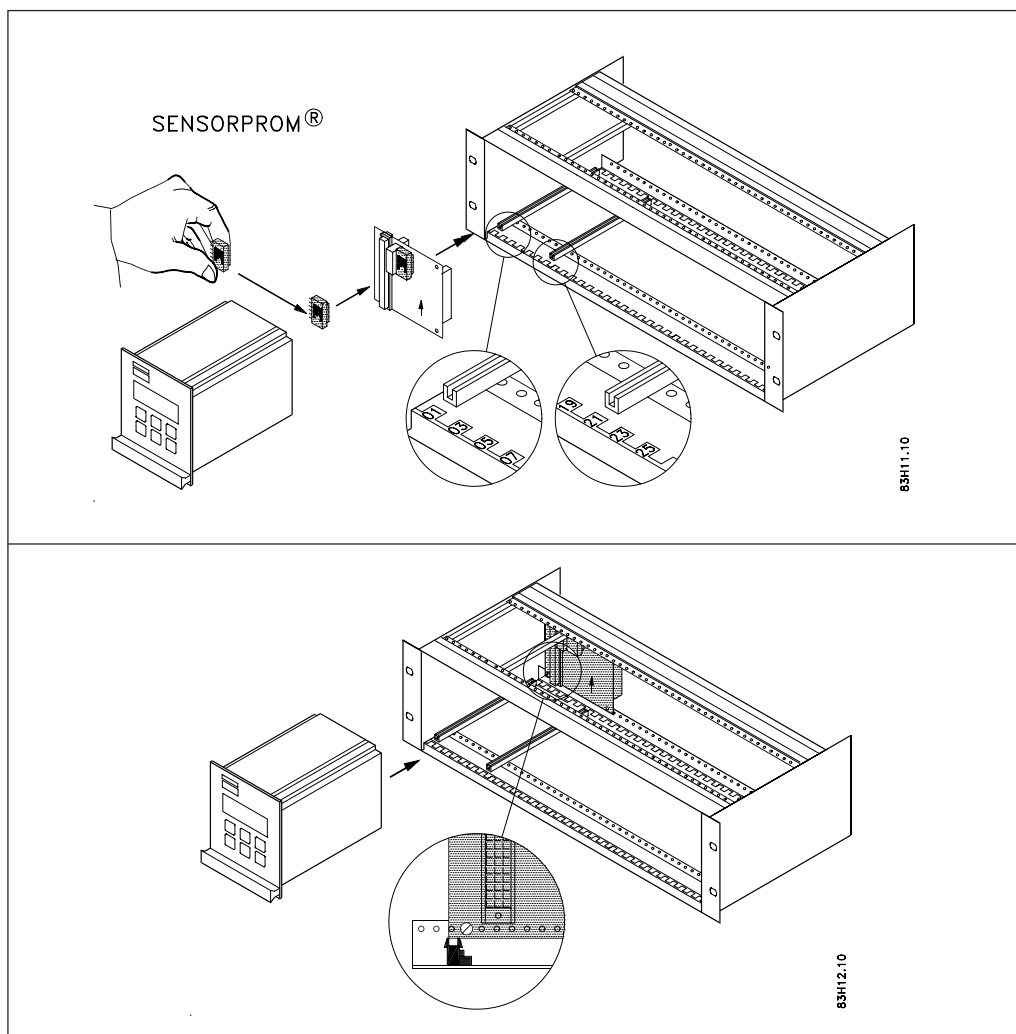

1. Fit the SENSORPROM® unit on the connection board supplied with the signal converter. The SENSORPROM® unit is supplied with the sensor.
2. Mount the guide rails in the rack system as shown. Distance between guide rails is 21 TE. Guide rails are supplied with the rack system and not with the signal converter.
3. Mount the connection board as shown. The left side of the connection board must flush to the left of the guide rail.
4. Connect the cables as shown under "Electrical connection".
5. Plug the signal converter into the rack system.

3. Technical data

3.1 Signal converter MASS 6000

	MASS 6000 Compact IP 67 and 19" IP 20 version
Measurement of	Mass flow [kg/s], volume flow [l/s], fraction [%], Brix, density [kg/m ³], temperature [°C]
Current output	
<i>Current</i>	0-20 mA or 4-20 mA
<i>Load</i>	< 800 ohm
<i>Time constant</i>	0-30 s adjustable
Digital output	
<i>Frequency</i>	0-10 kHz, 50% duty cycle
<i>Time constant</i>	0-30 s adjustable
<i>Active</i>	24 V d.c., 30 mA, 1 KΩ ≤ R _{load} ≤ 10 KΩ, short-circuit-protected
<i>Passive</i>	3-30 V d.c., max. 110 mA, 1 KΩ ≤ R _{load} ≤ 10 KΩ
Relay	
<i>Type</i>	Change-over relay
<i>Load</i>	42 V / 2 A peak
<i>Functions</i>	Error level, error number, limit, direction
Digital input	11-30 V d.c.
<i>Functionality</i>	Start/hold/continue batch, zero-point adjust, reset totalizer 1/2, force output, freeze output
Galvanic isolation	All inputs and outputs are galvanically isolated, isolation voltage 500 volts
Cut-off	
<i>Low-flow</i>	0-9.9% of maximum flow
Limit function	Mass flow, volume flow, fraction, density, sensor temperature
Totalizer	Two eight-digit counters for forward, net or reverse flow
Display	Background illumination with alphanumerical text, 3 × 20 characters to indicate flow rate, totalized values, settings and faults.
	Reverse flow indicated by negative sign
Zero-point adjustment	Manual via keypad or remote via digital input
Ambient temperature	Operation: -20 to +50°C
	During storage: -40 to +70°C (Humidity max. 95%)
Communication	Prepared for client mounted add-on modules
Enclosure compact IP 67	
<i>Material</i>	Fibre glass-reinforced polyamide
<i>Rating</i>	IP 67 to IEC 529 and DIN 40050 (1 m w.g. for 30 min.)
<i>Mechanical load</i>	18-1000 Hz random, 3.17G rms, in all directions, to IEC 68-2-36
Enclosure 19"	
<i>Material</i>	Aluminium/steel (DIN 41494)
<i>Rating</i>	IP 20 to IEC 529 and DIN 40050 (1 m w.g. for 30 min.)
<i>Mechanical load</i>	18-1000 Hz random, 3.17G rms, in all directions, to IEC 68-2-36
Supply voltage	115/230 V a.c. +10% to -10%, 50-60 Hz
	18-30 V d.c. or 20-30 V a.c.
Power consumption	230 V a.c.: 9 VA max.
	24 V d.c.: 6 W I _N = 250 mA, I _{ST} = 2A (30 msec)
EMC performance	
<i>Emission</i>	EN 50081-1 (Light industry)
<i>Immunity</i>	EN 50082-2 (Industry)
Ex-approval	[EEx ia] II C, DEMKO Ex99E.125729X
Maintenance	The flowmeter has a built-in error log/pending menu which should be inspected on a regular basis
Fuse	T 400 mA, T 250 V (IEC 127). Not replaceable by operator

4. Electrical connection
4.1 Signal converter
MASS 6000

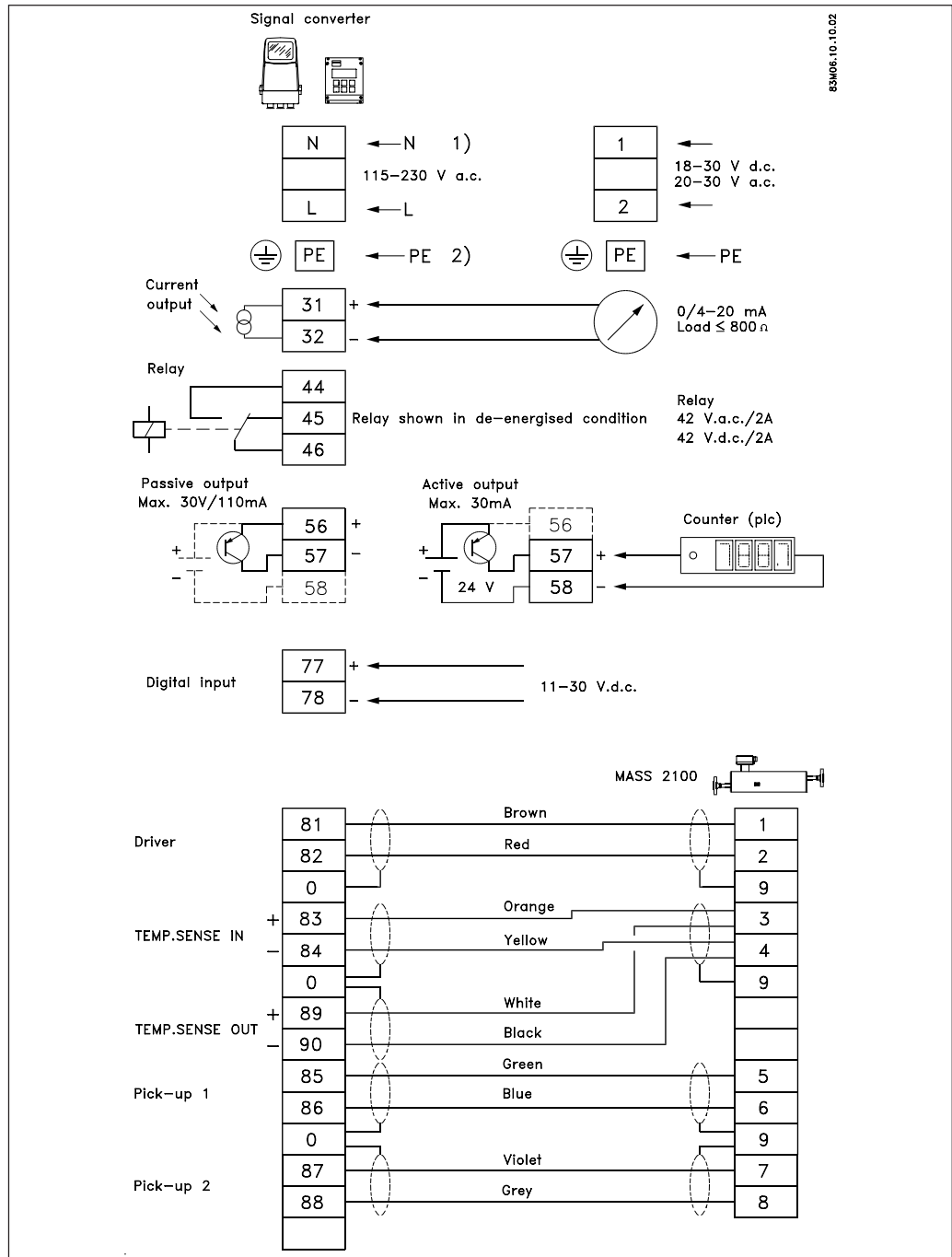

Installation



- 1) Mains supply 115 to 230 V a.c. from building installation Class II. A switch or circuit-breaker (max. 15 A) shall be included in the building installation. It must be in close proximity to the equipment and within easy reach of the OPERATOR, and it shall be marked as the disconnecting device for the equipment.
- 2) **The mains protective earth wire must be connected to the PE terminal, if the earth wire is not connected, personnel can be exposed to 115V/230V.**
 Required cable min. AGW16 or 1.5 mm² Cu wire.
 The insulation between the connected mains supply and 24 V a.c./d.c. supply for the flowmeters, models 24 V a.c./d.c. shall at least be rated with double or reinforced insulation at mains voltage.
 For field wiring installation **National Installation Code** shall be met of the country, where the flowmeters are installed.
 Main voltage terminals must be out of reach for OPERATOR to avoid any hazards!

Digital output

If the internal resistance of the loads exceeds 10KΩ, it is recommended to connect an external 10KΩ load resistor in parallel to the load.

4.2 Output characteristics
MASS 6000

Output characteristics 0-20 mA	Bidirectional mode		Unidirectional mode	
4-20 mA				
Frequency				
Pulse output				
Relay	Power supply off 	Power supply on 		
Error relay	No error 	Error 		
Limit switch or direction switch	1 set point 		2 set points 	
	Low flow (Reverse flow) 	Intermediate flow 		
	High flow (Forward flow) 	High flow/ Low flow 		
Batch on digital output				

5. Commissioning
5.1 Menu overview

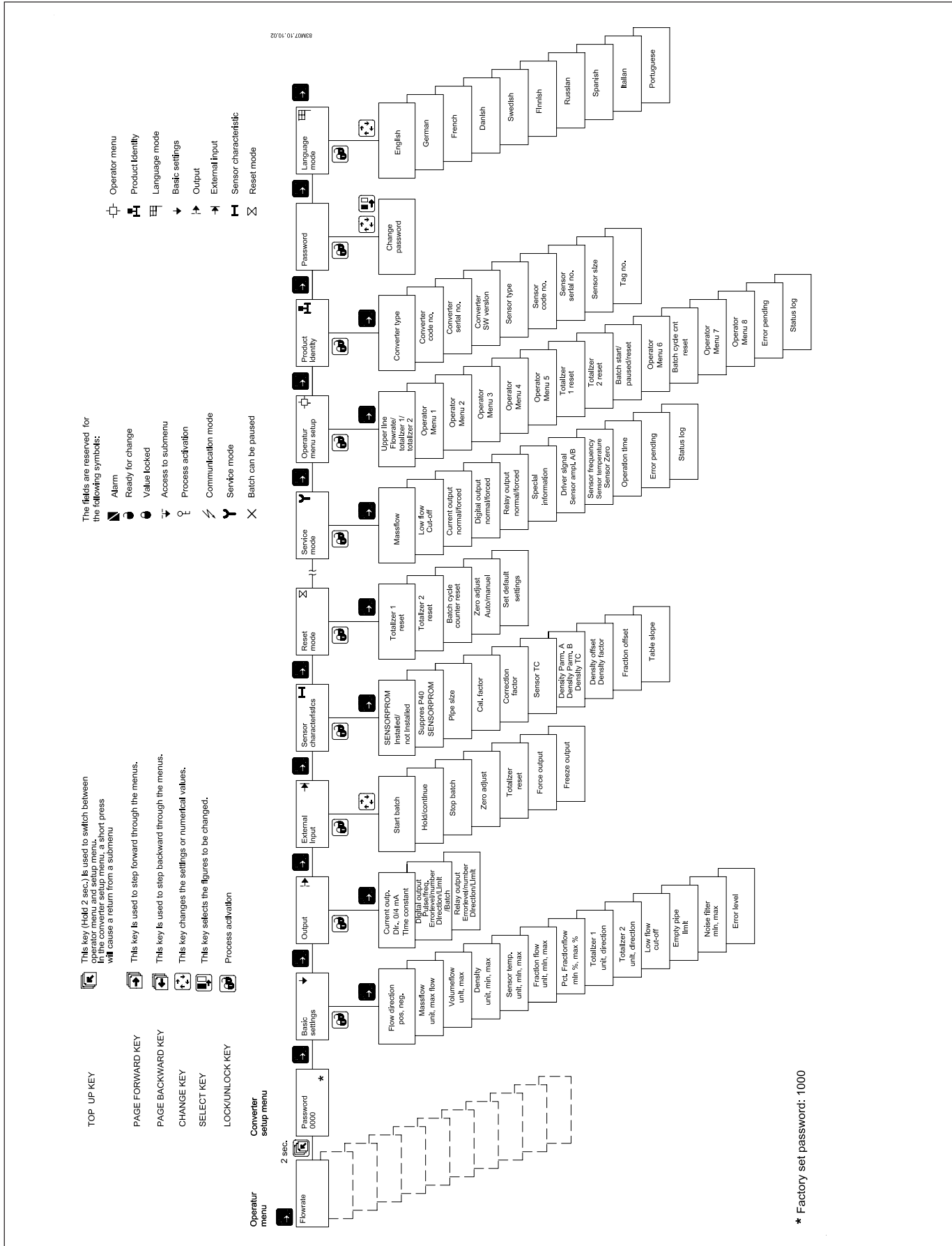



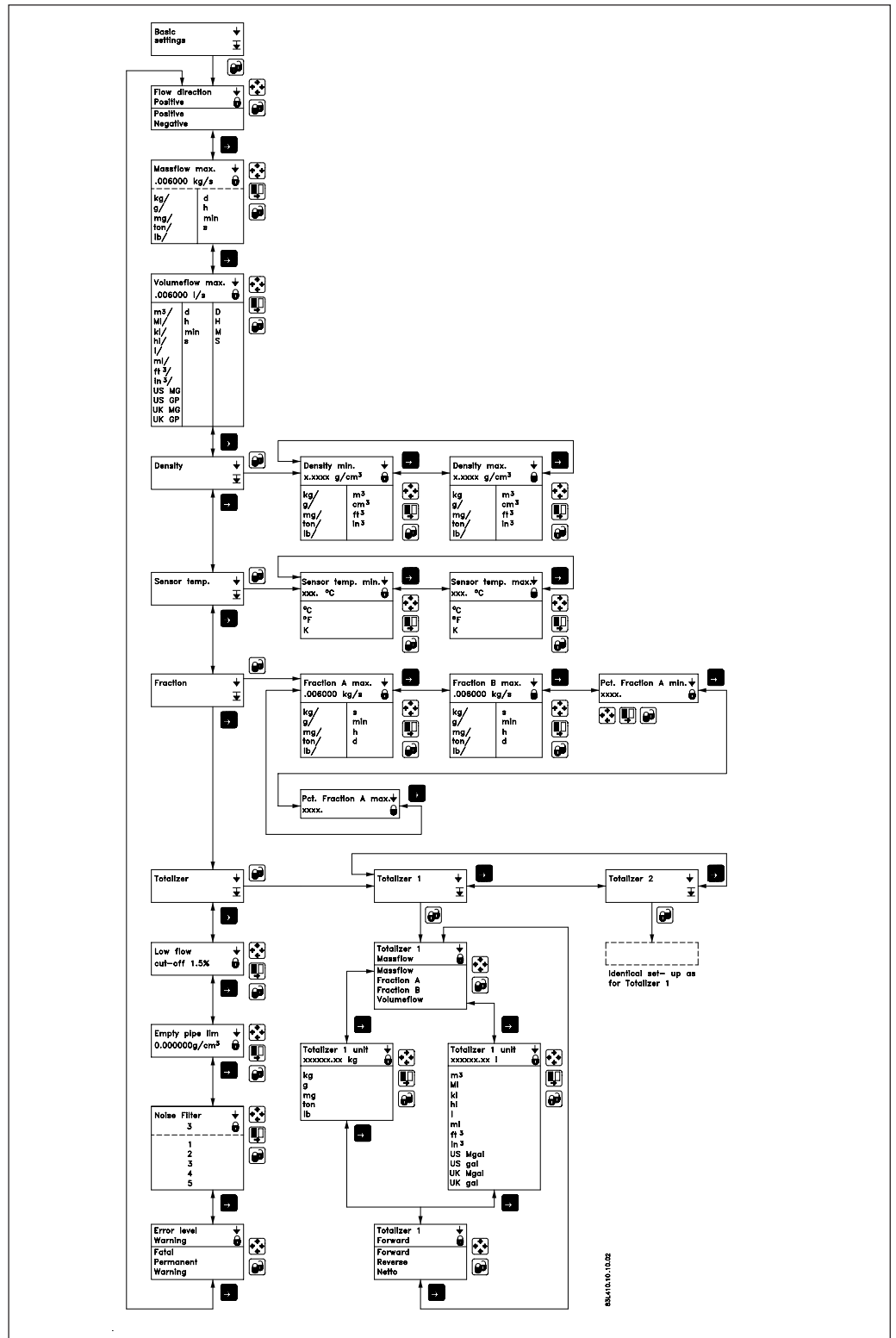

5.2 Menu details

Basic settings menu



Comma for flowrate, totalizer 1 and totalizer 2 can be individually positioned.

- open the respective window.
- ensure that the cursor is positioned below the comma. Use the SELECT KEY .
- move the comma to the requested position. Use the CHANGE KEY .

Units are changed by means of the CHANGE KEY  with the cursor placed below the unit selected. Select units (cursor moved) by means of the SELECT KEY .

Totalizer 2 is not visible when batch is selected as digital output.

5.3 Outputs setting menu

Current output

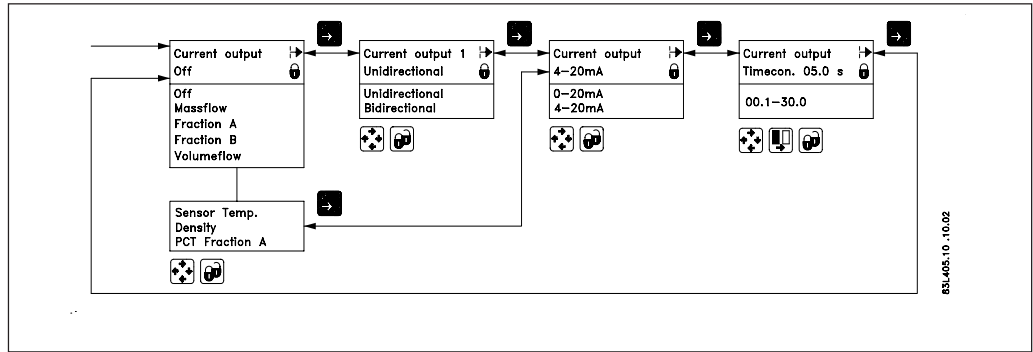

The current output must be set off when not used.

Digital output Pulse

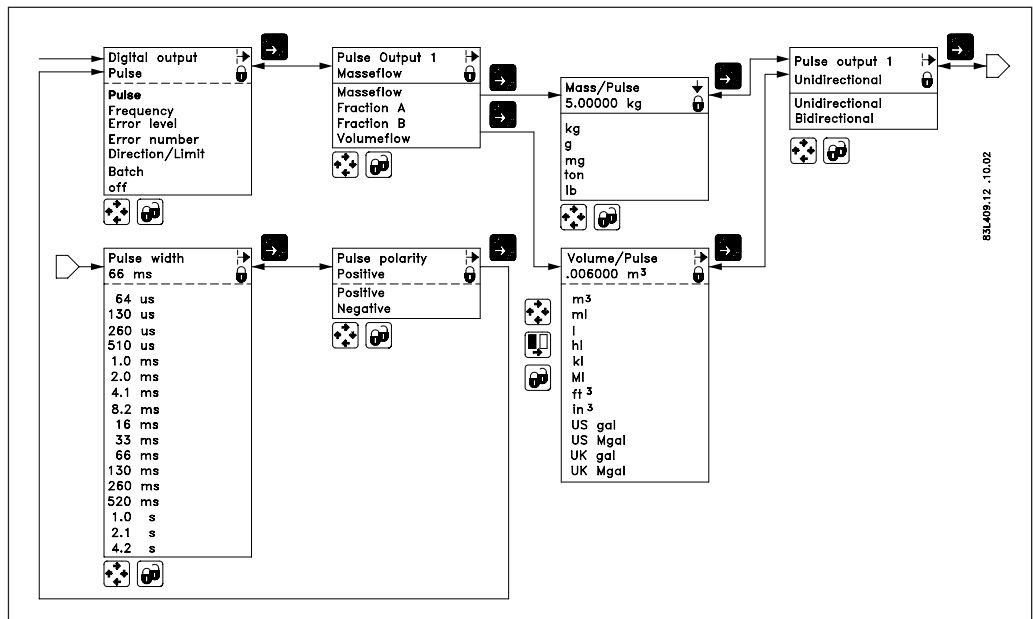

Digital output Frequency

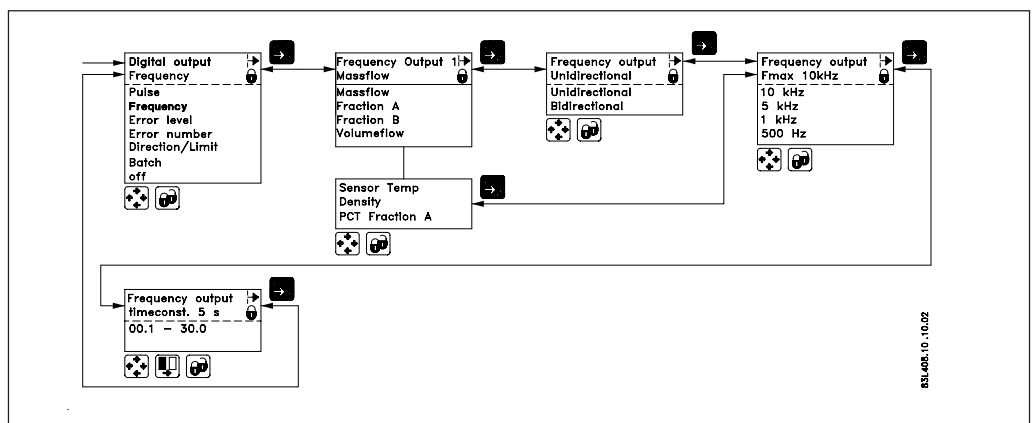

**Digital output
Batch**

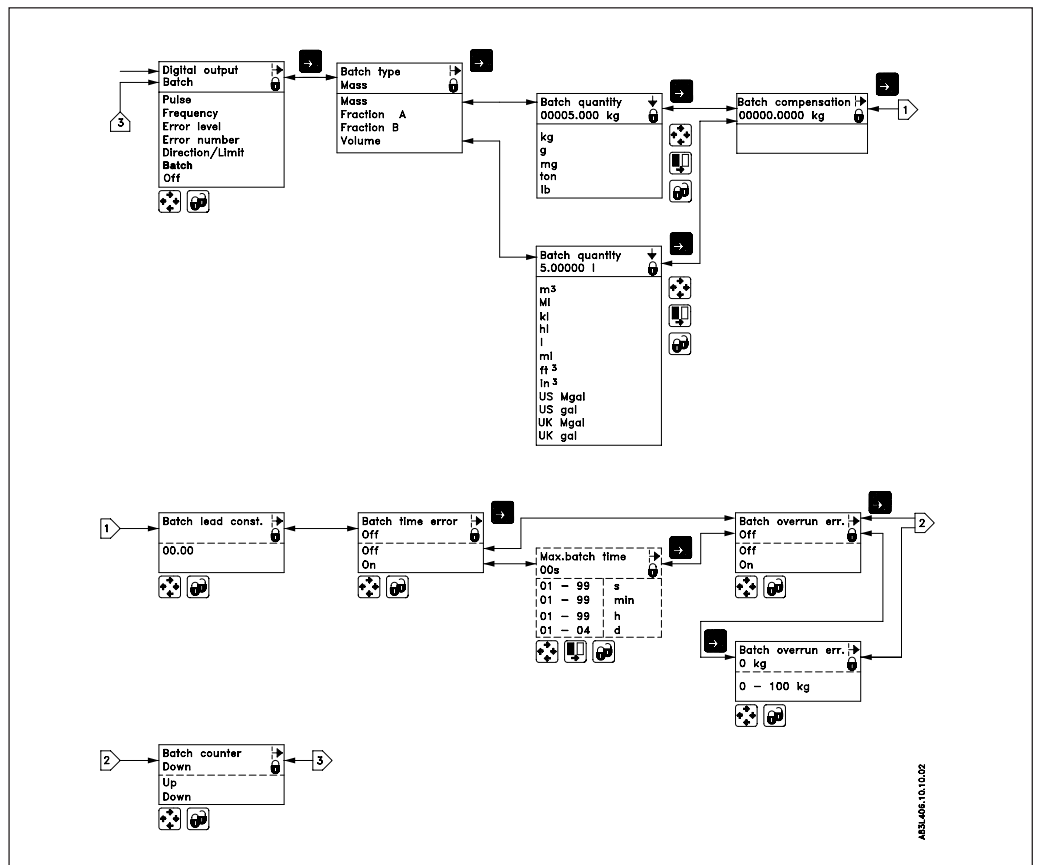

Relay output

Error level
(Also possible through digital output)

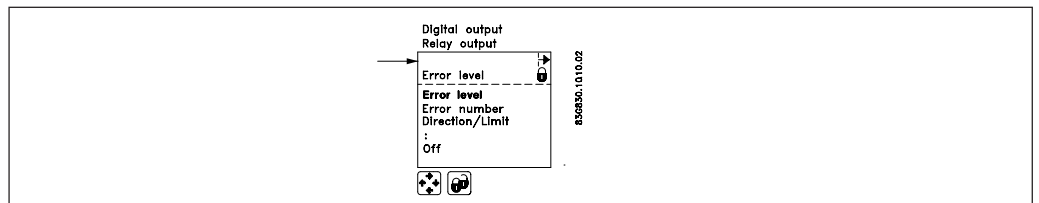

Acceptance level is set in the basic settings menu.

Error number
(Also possible through digital output)

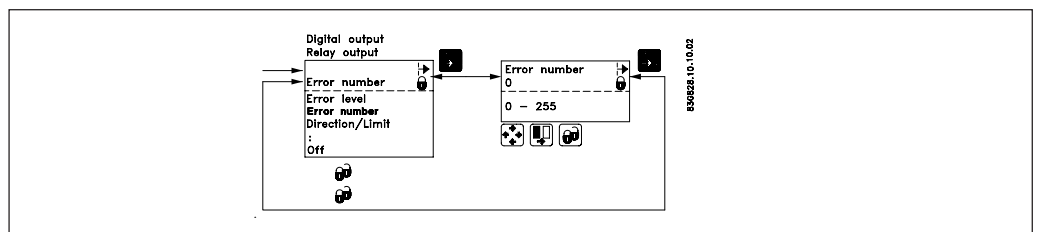

**Limit switch & direction
switch**
(Also possible through digital output)

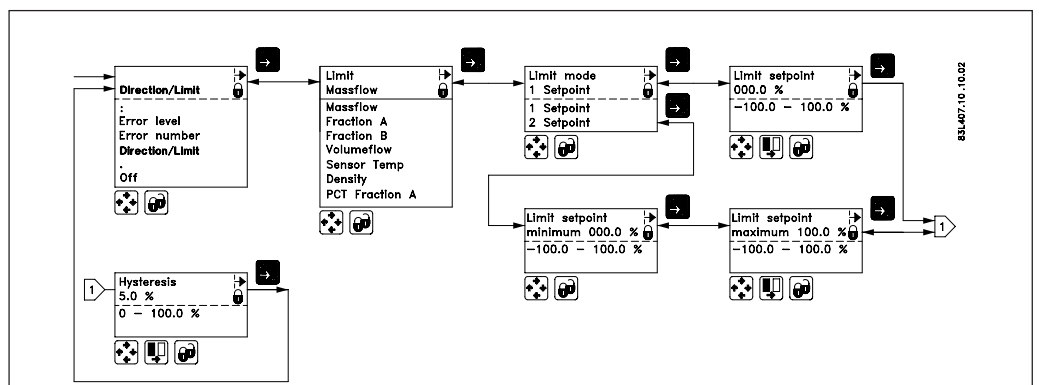

Direction flow: Select 1 setpoint at zero flow; Hysteresis at 5 %.

6. Service

6.1 List of error numbers

Error No.	Error text Remedy text	#Comment	Outputs status	Input status
1	I1 - Power on OK	Power on has happened	Active	Active
2	I2 - Add-on Module Applied	A new module has been applied to the system	Active	Active
3	I3 - Add-on Module Install	An add-on module is defect or has been removed. This can also be an internal add-on module	Active	Active
4	I4 - Param. corrected OK	A less vital parameter in the converter has been replaced by its default value	Active	Active
20	W20 - Totalizer 1 Reset manually	During initialisation the check of the saved totalize value has failed. It is not possible to rely on the saved totalizer value any more. The totalizer value must be reset manually in order to rely on future readings	Active	Active
20	W20 - Totalizer 2 Reset manually	During initialisation the check of the saved totalize value has failed. It is not possible to rely on the saved totalizer value any more. The totalizer value must be reset manually in order to rely on future readings	Active	Active
21	W21 - Pulse overflow Adjust pulse settings	Actual flow is too big compared with pulse width and mass/pulse	Reduced pulse width	Active
22	W22 - Batch timeout Check installation	Duration of batching has exceeded a predefined max. time	Batch output on zero	Active
23	W23 - Batch overrun Check installation	Batch quantity has exceeded a predefined maximum overrun mass or volume	Batch output on zero	Active
24	W24 - Batch neg. flow Check flow direction	Negative flow direction during batch	Active	Active
30	W30 - Flowsaturated Adjust max. flow	Flow is above Q_{max} settings	Max. 120 %	Active
31	W31 - Empty pipe	Pipe is empty	Zero	Active
32	W32 - Temp. to high Adjust temperature	The temperature of the fluid has exceeded the max. temperaturerating of the sensor (180 °C)	Active	Active
33	W33 - Temp. to low Adjust temperature	The temperature of the fluid has exceeded the min. temperaturerating of the sensor (-50 °C)	Active	Active
34	W34 - Zero Adj. fail Check flow = zero	The zero-pointadjustment values are outside the limit because there are not zero flow in the sensor. Check zeroflow conditions, valves, pumps etc.	Active	Active
35	W35 - Current Out 1 Check max. settings	Currentoutput exceeds 120%. Ensure that the sensor is correctly sized and check max. flow setting	Active	Active
36	W36 - Freq/Pulse Out1 Check max. settings	Freq/Pulseoutput exceeds 120%. Ensure that the sensor is correctly sized and check max. flow setting	Active	Active
40	P40 - SENSORPROM® Insert	SENSORPROM® unit not installed	Active	Active
41	P41 - Parameter range Switch off and on	A parameter is out of range. The error will disappear at the next power-on	Active	Active
42	P42 - Current output Check cables	Current loop is disconnected or the loop resistance is too big	Active	Active
43	P43 - Internal error Switch off and on	Internal error	Active	Active
49	P49 - Protec. viol. Switch off and on	Too many errors occured at the same time. Some errors are not detected correctly	Active	Active
50	P50 - Temp. cable Check cable	Error in temperaturesensor, check cables and connectors	Active	Active
51	P51 - Pickup 1 Check cable/install.	Pickup 1 amplitude too low. Check cables or application for damping (air/gaz in liquid)	Active	Active
52	P52 - Pickup 2 Check cable/install.	Pickup 2 amplitude too low. Check cables or application for damping (air/gaz in liquid)	Active	Active
60	F60 - CAN comm. error Converter/AOM	CAN bus communication error. An add-on module, the display module or the converter is defect	Zero	Inactive
61	F61 - SENSORPROM® err. Replace	It is not possible to rely on the data in SENSORPROM® unit any more	Active	Active
62	F62 - SENSORPROM® ID Replace	The SENSORPROM® unit ID do not comply with the product ID. The SENSORPROM® unit is from another type of product SITRANS FC MASSFLO, SITRANS F US SONOFLO etc.	Zero	Inactive
63	F63 - SENSORPROM® Replace	It is not possible to read from the SENSORPROM® unit any more	Active	Active
70	F70 - Pickup phase	Check cables/pol	Active	Active
71	F71 - Driver phase	Check cables/pol	Active	Active
80-83	F80, 81, 82, 83 - Internal error	Restart or replace	Active	Active
84	F84 - Sensor level	Sensor jammed	Active	Active
97	F97 - AOM to old	Replace	Active	Active

Error code level:

W = Warning, F = Fatal, P = Permanent

6.2 Trouble shooting
MASS 6000

Symptom	Output signals	Error code	Cause	Remedy
Empty display	Minimum		1. Supply voltage 2. MASS 6000 defective	1. Check supply voltage 2. Replace MASS 6000
No flow signal	Minimum		1. Current output deselected 2. Digital output deselected 3. Reverse flow direction	1. Activate current output 2. Activate digital output 3. Change direction
		W31	Measuring pipe empty	Ensure that the measuring pipe is full
		F60	Internal error	Replace MASS 6000
	Undefined	P42	1. No load on current output 2. MASS 6000 defective	1. Check cables/connections 2. Replace MASS 6000
		P41	Initializing error	Switch off MASS 6000, wait 5 s and switch on again
Indicates flow with no flow in pipe	Undefined		Measuring pipe empty	Select empty pipe limit Ensure that the measuring pipe is full of liquid
			Electrode cable is insufficiently screened	Ensure that electrode cable is connected and sufficiently screened
Unstable flow signal	Unstable		1. Pulsating flow 2. Air bubbles in medium 3. Vibrations 4. Pumpnoise	1. Increase time constant 2. Ensure medium does not contain air bubbles 3. Ensure that the sensor is mounted on a rigid frame without vibrations 4. Ensure that pump frequency is different from resonance frequency of sensor
Measuring error	Undefined		Faulty zero-point	Make new zero-point adjustment
		P40	No SENSORPROM® unit	Install SENSORPROM® unit
		F61	Deficient SENSORPROM® unit	Replace SENSORPROM® unit
		F62	Wrong SENSORPROM® unit	Replace SENSORPROM® unit
		F63	Defective SENSORPROM® unit	Replace SENSORPROM® unit
		F70	Loss of internal data	Replace MASS 6000
	Maximum	W30	Flow exceeds 120% of Q_{max} .	Check Q_{max} . (Basic Settings)
		W21	Pulse overflow • Mass/pulse too small • Pulse width too large	Change mass/pulse Change pulse width
Loss of totalizer data	OK	W20	Initializing error	Reset totalizer manually

