

Transmitter

For gas density, temperature and pressure of SF₆ gas

Model GDT-20, with Modbus® output

WIKA data sheet SP 60.09

Applications

- Permanent monitoring of the relevant gas condition parameters in closed tanks
- For internal and external SF₆-insulated equipment

Special features

- High-accuracy sensor technology
- Modbus® output protocol via RS-485 interface
- Ingress protection IP65
- Very good long-term stability and EMC characteristics
- Compact dimensions



Transmitter model GDT-20

Description

The model GDT-20 transmitter is a multi-sensor system with digital output for the measurands of pressure and temperature. Based on these measured values, the condition-related data can be determined.

Permanent monitoring

In order to prevent system failures in switchgear and network outages, the permanent monitoring of the gas density is essential.

The GDT-20 transmitter calculates the current gas density from the pressure and temperature using a complex virial equation in the transmitter's powerful microprocessor. Changes in pressure resulting from thermal effects will be compensated by this and will not affect the output value.

Modbus® fieldbus

The RS-485 interface communicates using the Modbus® RTU protocol. The instrument's output parameters and their units can be configured and read according to requirements. The GDT-20 can be configured later by the customer for each defined SF₆ gas mixture with N₂ or CF₄.

Signal stability

Due to its high long-term stability, the transmitter is maintenance-free and requires no recalibration. Due to the hermetically sealed weld seam and a measuring cell design without sealing elements, the permanent sealing of the measuring cell is ensured.

The EMC characteristics fulfil the IEC 61000-4-2 through to IEC 61000-4-6 standards and guarantee an interference-free data output.

Specifications

Accuracy specifications		
Accuracy	The specifications only valid for pure SF ₆ gas	
Density	±0.6 %, ±0.35 g/litre at -40 ... +80 °C [-40 ... +176 °F]	
Temperature	±1 K	
Pressure	-40 ... < 0 °C [-40 ... +32 °F]	±0.2 %, ±32 mbar
	0 ... 80 °C [32 ... 176 °F]	±0.06 %, ±10 mbar
Refresh rate		
Density	20 ms	
Temperature	20 ms	
Pressure	20 ms	
Long-term stability at reference conditions		
Temperature	≤ ±0.1 % of span/year	
Pressure	≤ ±0.05 % of span/year	

Measuring ranges	
Density	0 ... 60 g/litre (8.87 bar abs. at 20 °C [68 °F])
Temperature	-40 ... +80 °C [-40 ... +176 °F]
Pressure	0 ... 16 bar abs.
Burst pressure	52 bar abs.
Overpressure limit	Up to 30 bar abs.
Pressure reference	Absolute
Unit	Measured values with alternative units can be retrieved directly in the Modbus® registers
Density	g/litre, kg/m ³
Temperature	°C, °F, K
Pressure	mbar, Pa, kPa, MPa, psi, N/cm ² , bar (at 20 °C [68 °F])

Process connection	
Thread	G ½" B, male thread
Material	Stainless steel
Transmission fluid	Synthetic oil

Output signal	
Voltage supply U_B	DC 17 ... 30 V
Power consumption	Max. 0.5 W

Electrical connection	
Connection type	<ul style="list-style-type: none"> ■ Circular connector M12 x 1 (5-pin) ■ Modbus® RTU via RS-485 interface
Modbus® functionality	<ul style="list-style-type: none"> ■ Mixture ratio of SF₆ to N₂ or CF₄ (factory setting: 100 % SF₆ gas) ■ Customer-specific sensor name

Pin assignment

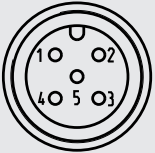
Circular connector M12 x 1 (5-pin)			
	1	-	-
	2	U _{B+}	Voltage supply
	3	U _{B-}	Ground
	4	A	Signal RS-485
	5	B	Signal RS-485

Material	
Process connection	Stainless steel
Case	Stainless steel

Operating conditions		
Permissible temperature ranges		
Standard	Operation	-40 ... +80 °C [-40 ... +176 °F]
	Storage	-40 ... +80 °C [-40 ... +176 °F]
Option	Operation	-60 ... +80 °C [-76 ... +176 °F]
	Storage	-60 ... +80 °C [-76 ... +176 °F]
Permissible air humidity	≤ 90 % r. h. (non-condensing)	
Ingress protection IP (IP code) per IEC 60529	IP65, only when plugged in and using mating connectors with the corresponding ingress protection	
Electrical safety	Protected against reverse polarity, protected against overvoltage	
EMC tests	Immunity per IEC 61000-4-3	30 V/m (80 MHz ... 2.7 GHz)
	Burst per IEC 61000-4-4	4 kV
	Surge immunity per IEC 61000-4-5	2 kV conductor to ground, 1 kV conductor to conductor
	ESD per IEC 61000-4-2	8 kV/15 kV, contact/air
	High-frequency fields per IEC 61000-4-6	10 V

Approvals

Logo	Description	Country
	EAC	Eurasian Economic Community
	EMC directive	
-	CRN Safety (e.g. electr. safety, overpressure, ...)	Canada

Manufacturer's information and certificates

Logo	Description
-	China RoHS directive

Dimensions in mm

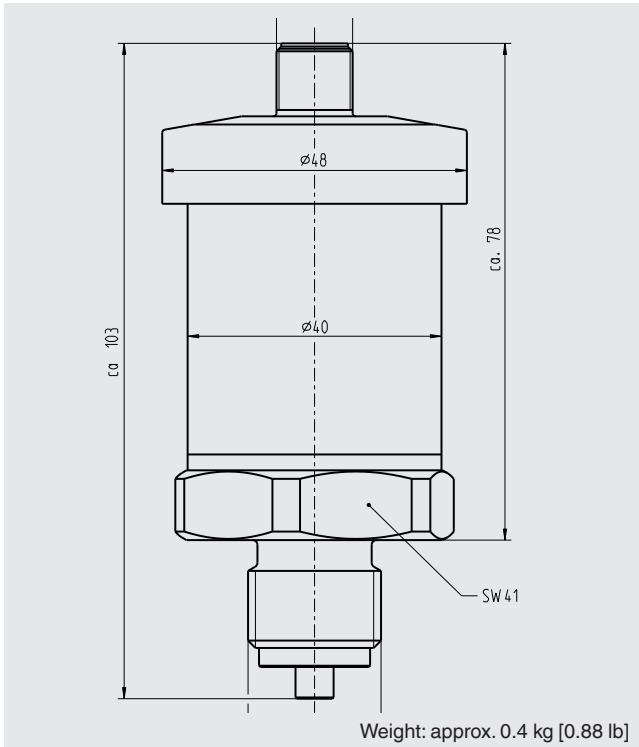

Accessories

Designation	Order number
Modbus® startup kit for configuration, consisting of: <ul style="list-style-type: none"> ■ Power supply unit for transmitter ■ Cable with M12 x 1 connector ■ Interface converter (RS-485 to USB) ■ USB cable type A to type B ■ Modbus® tool software on USB stick 	14075896

Ordering information

Model / Permissible ambient temperature / Accessories

© 08/2013 WIKA Alexander Wiegand SE & Co. KG, all rights reserved.
The specifications given in this document represent the state of engineering at the time of publishing.
We reserve the right to make modifications to the specifications and materials.