

Transmitter

For density, temperature, pressure and humidity of SF₆ gas Model GDHT-20, with MODBUS® output



for further approvals
see page 3

Applications

- Permanent monitoring of the relevant gas condition parameters in closed tanks
- For internal and external SF₆ gas-insulated equipment

Special features

- High-accuracy sensor technology
- MODBUS® output protocol via RS-485 interface
- Ingress protection IP65
- Very good long-term stability and EMC characteristics
- Compact dimensions



Transmitter, model GDHT-20

Description

The model GDHT-20 transmitter is a multi-sensor system with digital output for the measurands of pressure, temperature and humidity. Based on these measured values, the condition-related data can be determined.

Permanent monitoring

In order to prevent system failures in switchgear and, with that, network outages, the permanent monitoring of the gas density and moisture content is essential.

The GDHT-20 transmitter calculates the current gas density from the pressure and temperature using a complex virial equation in the transmitter's powerful microprocessor. Pressure changes resulting from thermal effects will be compensated by this and will not affect the output value.

In addition, the GDHT-20 transmitter delivers humidity or dew point information, which enables monitoring within the terms of the Cigré directives and IEC standards.

MODBUS® fieldbus

The RS-485 interface communicates using the MODBUS® RTU protocol. The instrument's output parameters and their units can be configured and read according to requirements. The GDHT-20 transmitter can be configured later by the customer for each defined SF₆ gas mixture with N₂ or CF₄.

Signal stability

Due to its high long-term stability, the transmitter is maintenance-free and requires no recalibration. Due to the hermetically sealed weld seam and a measuring cell design without sealing elements, the permanent sealing of the measuring cell is ensured.

The EMC characteristics fulfil the IEC 61000-4-2 through to IEC 61000-4-6 standards and guarantee an interference-free data output.

Specifications

Measuring ranges

Dew point at ambient pressure:	-50 ... +30 °C
Density:	0 ... 60 g/litre (8.87 bar abs. SF ₆ gas at 20 °C)
Temperature:	-40 ... +80 °C
Pressure at 20 °C:	0 ... 8,87 bar abs. SF ₆ gas
Pressure:	0 ... 16 bar abs.
Burst pressure:	52 bar abs.
Overload safety:	Up to 30 bar abs.
Pressure reference:	Absolute

Accuracy¹⁾

Specifications only valid for clean gaseous SF ₆	
Dew point:	±3 K
Density:	±0.60 %, ±0.35 g/litre (-40 ... 80 °C)
Temperature:	±1 K
Pressure:	±0.20 %, ±32 mbar (-40 ... < 0 °C) ±0.06 %, ±10 mbar (0 ... 80 °C)

Long-term stability at reference conditions²⁾

Temperature:	≤ ±0.10 % of span/year
Pressure:	≤ ±0.05 % of span/year
Dew point:	≤ ±0.50 % of span/year

Refresh rate

Density:	20 ms
Temperature:	20 ms
Pressure:	20 ms
Dew point:	2 s (typical), auto-adjustment cycle every 30 min.

Permissible ambient temperature

Selectable versions		
Standard	-40 ... +80 °C	-40 ... +80 °C
	-40 ... +176 °F	-40 ... +176 °F
Option	-60 ... +80 °C	-60 ... +80 °C
	-76 ... +176 °F	-76 ... +176 °F

Power supply U_B⁺

DC 17 ... 30 V

Power consumption

Max. 0.5 W (max. 3 W during the heating phase of the humidity sensor)

Electrical connection

Circular connector M12 x 1 (5-pin)
MODBUS[®] RTU via RS-485 interface

Circular connector M12 x 1 (5-pin)

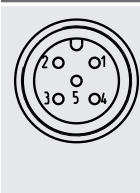
	1	-	-
	2	U _B ⁺	Power supply
	3	U _B ⁻	Ground
	4	A	Signal RS-485
	5	B	Signal RS-485

1) Following DIN EN 60770-2

2) per IEC 61298-2

Functionality MODBUS[®]

Mixture ratio of SF₆ to N₂ or CF₄ (default 100 % SF₆ gas)
Customer-specific sensor name

Measured values with alternative units can be retrieved directly in the MODBUS[®] registers.

- Density: g/litre, kg/m³
- Temperature: °C, °F, K
- Pressure: mbar, Pa, kPa, MPa, psi, N/cm², bar (at 20 °C)
- Humidity: ppmv, ppmw
- Dew point: °C
- Freezing point: °C
- Relative humidity: %

Process connections

Selectable versions

G 1 B, male thread, stainless steel
DN20, female thread
G ½ B, male thread
Malmkvist [®]
G ¾ JIS
Flange D40
M10 x 0.5
Via measuring chamber (see page 5)
DN8, female thread
Other connections on request

Case

Stainless steel

Permissible air humidity

≤ 90 % r. h. (non-condensing)

Ingress protection

IP65, only when plugged in and using mating connectors with the corresponding ingress protection

Electrical safety

Protected against reverse polarity, protected against overvoltage

Dimensions

Diameter: 48 mm
Height: 96 mm

Weight



Approx. 0.40 kg

EMC tests

For EMC, observe the installation instructions of the operating instructions.

- **Immunity per IEC 61000-4-3:**
30 V/m (80 MHz ... 2.7 GHz)
- **Burst per IEC 61000-4-4:** 4 kV
- **Surge immunity per IEC 61000-4-5:** 1 kV conductor to ground, 1 kV conductor to conductor
- **ESD per IEC 61000-4-2:** 8 kV/15 kV, contact/air
- **High-frequency fields per IEC 61000-4-6:** 3 V

Approvals

Logo	Description	Country
	EU declaration of conformity <ul style="list-style-type: none">■ EMC directive, EN 61326 emission (group 1, class B) and immunity (industrial application)■ RoHS directive	European Union
	EAC EMC directive	Eurasian Economic Community

Approvals and certificates, see website

Dimensions in mm

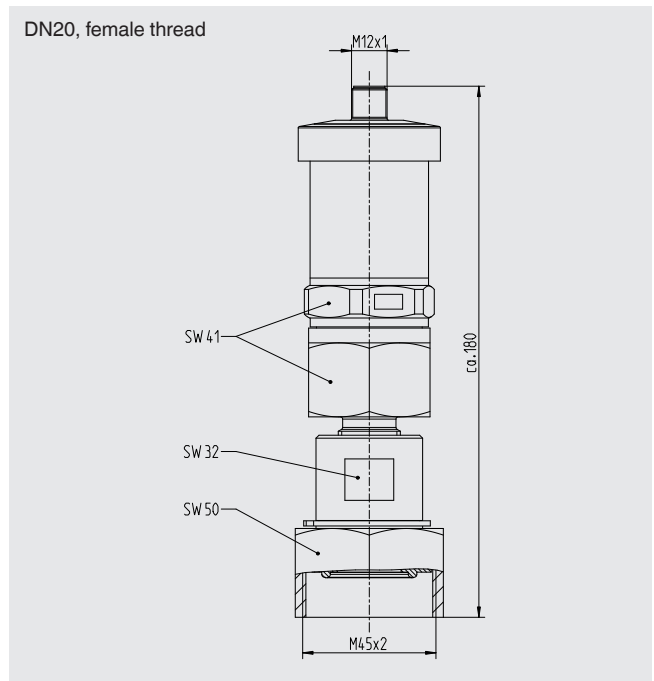
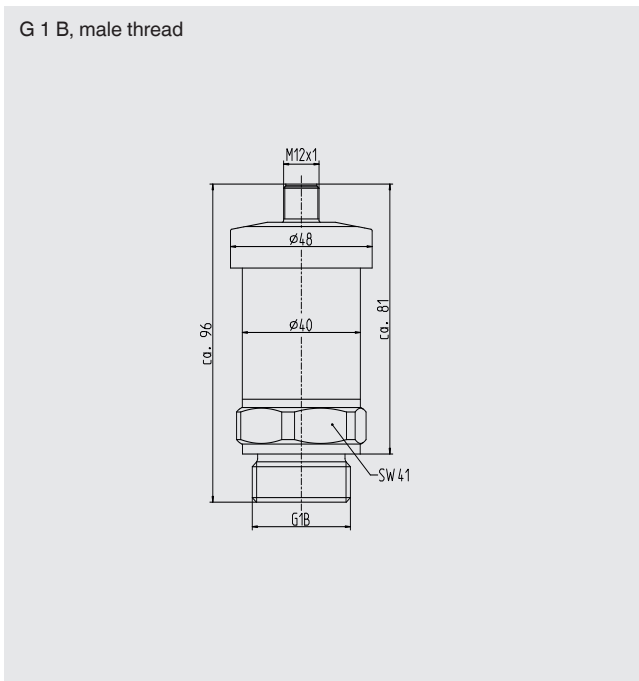

G 1/2 B, male thread

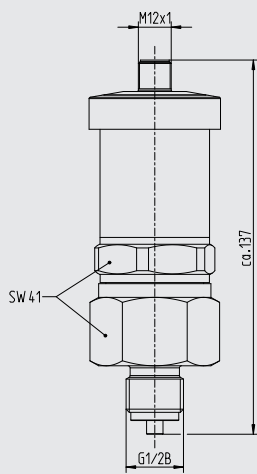

Malmkvist®

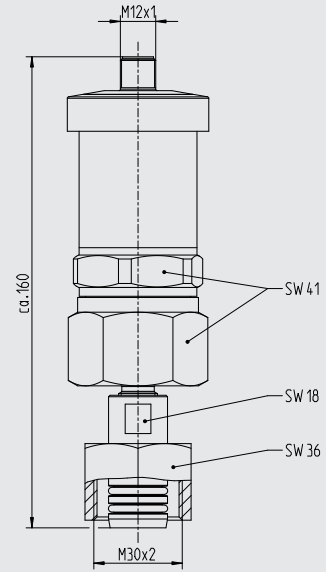

Measuring chamber, DN20

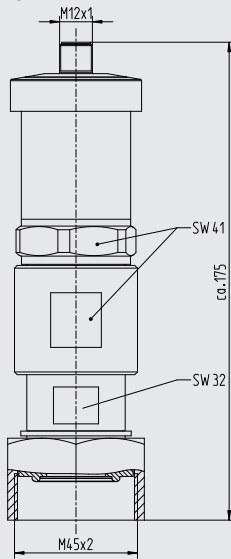

Measuring chamber, DN20, 90° angled

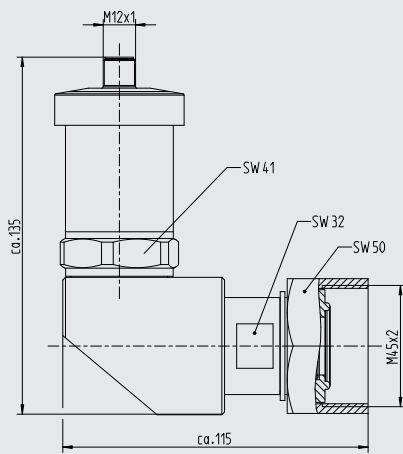

Measuring chamber, DN20 male thread / DN20 female thread

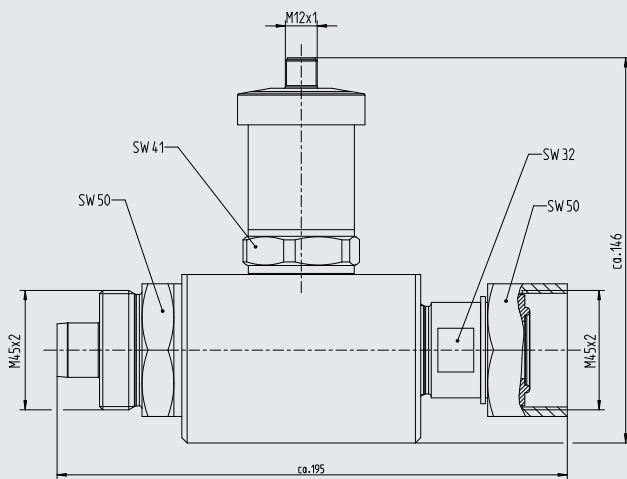

Measuring chamber, DN8 male thread / DN8 female thread

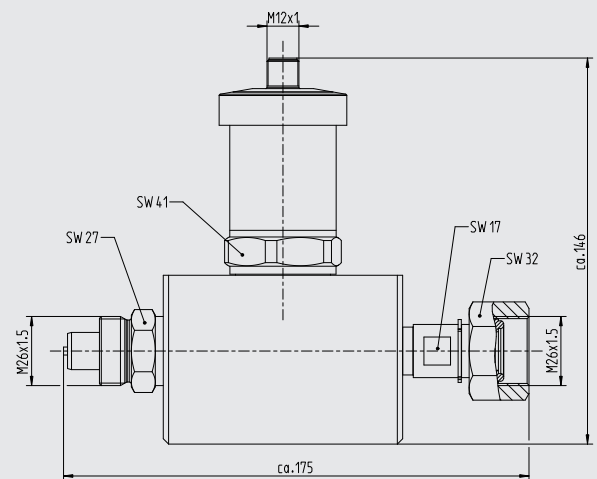

Measuring chamber, DN8 male thread / DN20 female thread

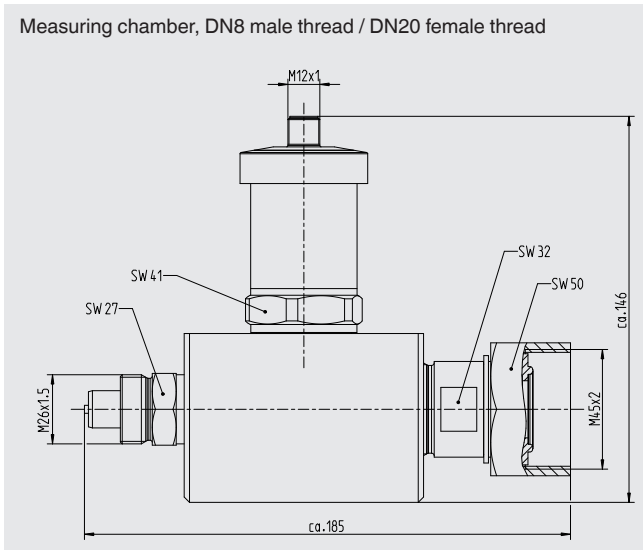

Measuring chamber, DN20 male thread / DN8 female thread

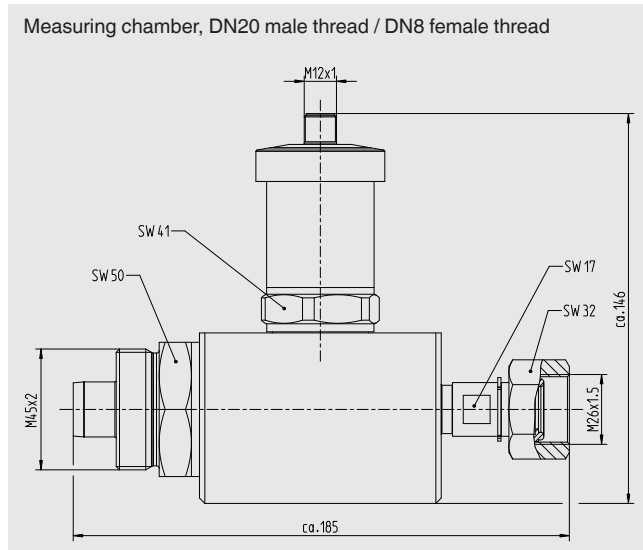

DN8, female thread

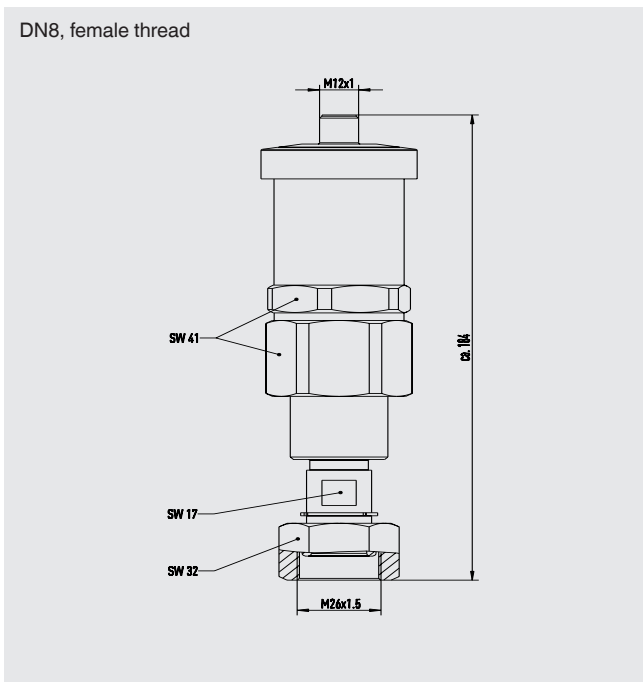

Accessories

Designation	Order number
Modbus® startup kit for measured value recording and configuration, consisting of: <ul style="list-style-type: none"> ■ Power supply unit for transmitter ■ Cable with M12 x 1 connector ■ Interface converter (RS-485 to USB) ■ USB cable type A to type B ■ Modbus® tool software 	14075896
WIKAsoft-GD for configuration and testing of the sensor	Free download from: www.wika.com/Download

Cable shielded, M12 x 1, AWG20	Order number
Length 1 m	14372501
Length 2 m	14372502
Length 3 m	14372503
Length 4 m	14372504
Length 5 m	14372505
Length 6 m	14372506
Length 7 m	14372507
Length 8 m	14372500
Length 9 m	14372509
Length 10 m	14372510
Length 15 m	14372511
Length 20 m	14372513
Length as required	On request

Conector	Shield	Order number
Y-connector, M12 x 1 (5-pin)	Sensor side unshielded	14294061
T-connector, M12 x 1 (5-pin)	Sensor side unshielded	14294063
Y-connector, M12 x 1 (5-pin)	Sensor side shielded	14271396
T-connector, M12 x 1 (5-pin)	Sensor side shielded	14109450
End piece, M12 x 1	-	14299963

If no cable will be installed between connector and sensor, we recommend using connectors which are unshielded on the sensor side.

Spare parts	Order number
Sealing for process connection G 1 B, male thread, (included in the standard scope of delivery.)	14046738

Installation example

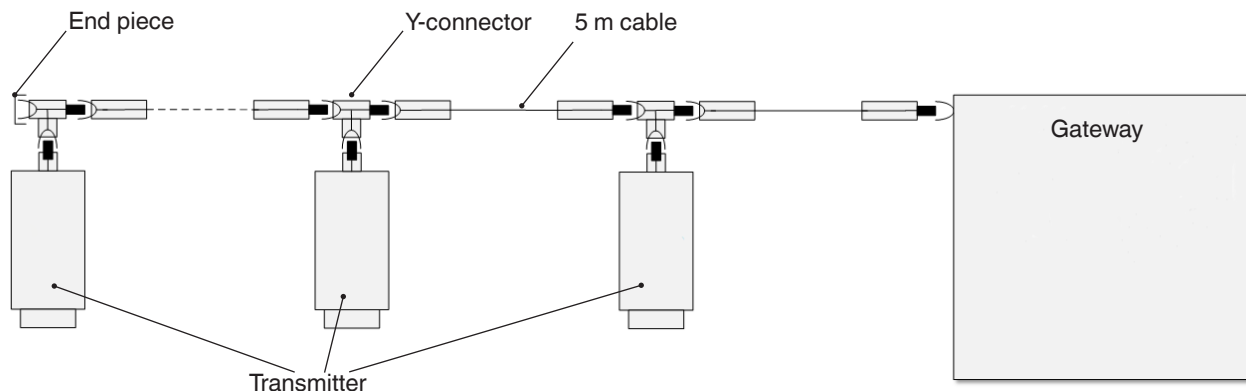

Ordering information

Model / Permissible ambient temperature / Process connection / Accessories

© 08/2013 WIKA Alexander Wiegand SE & Co. KG, all rights reserved.
The specifications given in this document represent the state of engineering at the time of publishing.
We reserve the right to make modifications to the specifications and materials.