



# ILMK 307T

## Level and Temperature Transmitter

Ceramic Sensor

accuracy according to IEC 60770:  
0.5 % FSO

### Nominal pressure / nominal temperature

from 0 ... 4 mH<sub>2</sub>O up to 0 ... 250 mH<sub>2</sub>O  
from 0 ... 30 °C up to 0 ... 70 °C  
others on request

### Output signals

2-wire: 4 ... 20 mA (pressure)  
2-wire: 4 ... 20 mA (temperature)

### Special characteristics

- ▶ diameter 26.5 mm
- ▶ separate output signals for pressure and temperature ranges
- ▶ good long term stability
- ▶ easy handling
- ▶ low maintenance and wiring costs

### Optional versions

- ▶ different kinds of cables and elastomers
- ▶ customer specific versions

The stainless steel submersible probe ILMK 307T with flush mounted ceramic sensor has developed for continuous level and temperature measurement in water or waste water applications.

The advantage: simultaneous recording of level and temperature with separate independent signal amplification. The maintenance and wiring costs are considerably reduced.

In addition to classical signal processing of the level, an additional signal circuit independent of the level which converts the temperature signal into a 4 ... 20 mA analogue signal in 2-wire technology is provided.

### Preferred areas of use are

#### Water



drinking water systems  
ground water monitoring  
domestic water tanks  
rain spillway basin



#### Sewage

waste water treatment, water recycling  
dumpsite, waste water tanks



#### Fuel and oil

fuel storage, tank farm, biogas plants



# ILMK 307T

Level and Temperature Transmitter

Technical Data

Input pressure range											
Nominal pressure gauge	[bar]	0.4	0.6	1	1.6	2.5	4	6	10	16	25
Level	[mH <sub>2</sub> O]	4	6	10	16	25	40	60	100	160	250
Overpressure	[bar]	1	2	2	4	4	10	10	20	40	40
Burst pressure ≥	[bar]	2	4	4	5	5	12	12	25	50	50
Max. ambient pressure (housing): 40 bar											
Input temperature range											
Temperature measuring range standard:		0 ... 30 °C	0 ... 50 °C	0 ... 70 °C	others on request <sup>1</sup>						
<sup>1</sup> min. temperature range: 30 °C; max. temperature range: 80 °C min. temperature: -10 °C; max. temperature: 70 °C											
Output signal / Supply											
2-wire (pressure) <sup>2</sup>		4 ... 20 mA / V <sub>S</sub> = 10 ... 30 V <sub>DC</sub>									
2-wire (temperature) <sup>2</sup>		4 ... 20 mA / V <sub>S</sub> = 10 ... 30 V <sub>DC</sub>									
<sup>2</sup> the circuits are galvanically isolated from each other											
Performance											
Accuracy (pressure) <sup>3</sup>		≤ ± 0.5 % FSO									
Accuracy (temperature) <sup>4</sup>		≤ ± 1 °C									
Permissible load		R <sub>max</sub> = [(V <sub>S</sub> - V <sub>S</sub> min) / 0.02 A] Ω									
Influence effects		supply: 0.05 % FSO / 10 V		load: 0.05 % FSO / kΩ							
Long term stability		≤ ± 0.3 % FSO / year at reference conditions									
Response time		< 10 msec (for output signal 2-wire (pressure))									
<sup>3</sup> accuracy according to IEC 60770 – limit point adjustment (non-linearity, hysteresis, repeatability) <sup>4</sup> Pt 100 class B; compensation time up to 1 h depending on constant temperature and environmental respectively mass conditions											
Thermal effects (Offset and Span)											
Thermal error		≤ ± 0.2 % FSO / 10 K		in compensated range 0 ... 70 °C							
Permissible temperatures											
Permissible temperatures		medium: -10 ... 70 °C		storage: -25 ... 70 °C							
Electrical protection <sup>5</sup>											
Short-circuit protection		permanent									
Reverse polarity protection		no damage, but also no function									
Electromagnetic compatibility		emission and immunity according to EN 61326									
<sup>5</sup> additional external overvoltage protection unit in terminal box KL 1 or KL 2 with atmospheric pressure reference available on request											
Electrical connection											
Cable with sheath material <sup>6</sup>		PVC ( -5 ... 70 °C)	grey	Ø 7.4 mm							
		PUR (-10 ... 70 °C)	black	Ø 7.4 mm							
		FEP <sup>7</sup> (-10 ... 70 °C)	black	Ø 7.4 mm							
		others on request									
Cable capacitance		signal line/shield also	signal line/signal line: 160 pF/m								
Cable inductance		signal line/shield also	signal line/signal line: 1 µH/m								
Bending radius		static installation:	10-fold cable diameter								
		dynamic application:	20-fold cable diameter								
<sup>6</sup> shielded cable with integrated ventilation tube for atmospheric pressure reference <sup>7</sup> do not use freely suspended probes with an FEP cable if effects due to highly charging processes are expected											
Materials (media wetted)											
Housing		stainless steel 1.4404 (316L)									
Seals		FKM EPDM others on request									
Diaphragm		ceramics Al <sub>2</sub> O <sub>3</sub> 96%									
Protection cap		POM-C									
Cable sheath		PVC, PUR, FEP									
Miscellaneous											
Current consumption		max. 25 mA									
Weight		approx. 250 g (without cable)									
Ingress protection		IP 68									
CE-conformity		EMC Directive: 2014/30/EU									

# ILMK 307T

Level and Temperature Transmitter

Technical Data

## Wiring diagram

2x2-wire-system (current)

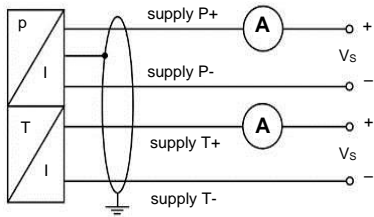

## Pin configuration

Electrical connection	cable colours (IEC 60757)
Supply P+	WH (white)
Supply P-	BN (brown)
Supply T+	GY (grey)
Supply T-	PK (pink)
Shield	GNYE (green-yellow)

## Dimensions (mm / in)

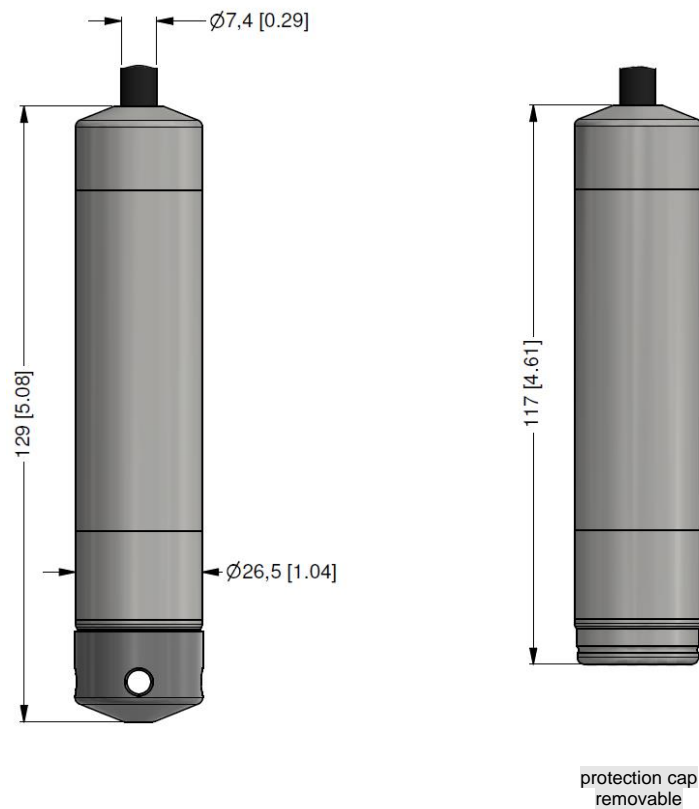

# ILMK 307T

Level and Temperature Transmitter

Accessories

## Mounting flange with cable gland

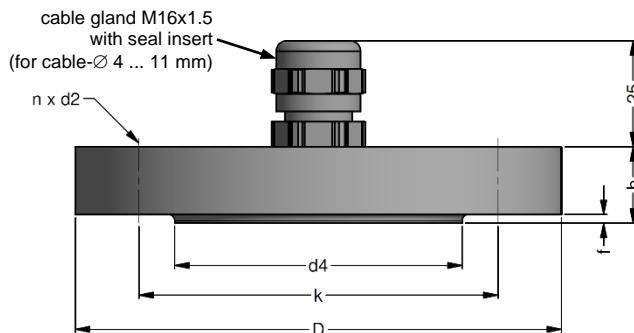

dimensions in mm			
size	DN25 / PN40	DN50 / PN40	DN80 / PN16
b	18	20	20
D	115	165	200
d2	14	18	18
d4	68	102	138
f	2	3	3
k	85	125	160
n	4	4	8

Technical data		
Suitable for	all probes	
Flange material	stainless steel 1.4404 (316L)	
Material of cable gland	standard: brass, nickel plated      on request: stainless steel 1.4305 (303); plastic	
Seal insert	material: TPE (ingress protection IP 68)	
Hole pattern	according to DIN 2507	
Ordering type	Ordering code	Weight
DN25 / PN40 with cable gland brass, nickel plated	ZMF2540	1.4 kg
DN50 / PN40 with cable gland brass, nickel plated	ZMF5040	3.2 kg
DN80 / PN16 with cable gland brass, nickel plated	ZMF8016	4.8 kg

## Terminal clamp



Technical data		
Suitable for	all probes with cable Ø 5.5 ... 10.5 mm	
Material of housing	standard: steel, zinc plated      optionally: stainless steel 1.4301 (304)	
Material of clamping jaws and positioning clips	PA (fibre-glass reinforced)	
Dimensions (mm)	174 x 45 x 32	
Hook diameter	20 mm	
Ordering type	Ordering code	Weight
Terminal clamp, steel, zinc plated	Z100528	approx. 160 g
Terminal clamp, stainless steel 1.4301 (304)	Z100527	

## Display program

- CIT 200** Process display with LED display
- CIT 250** Process display with LED display and contacts
- CIT 300** Process display with LED display, contacts and analogue output
- CIT 350** Process display with LED display, bargraph, contacts and analogue output
- CIT 400** Process display with LED display, contacts, analogue output and Ex-approval
- CIT 600** Multichannel process display with graphics-capable LC display
- CIT 650** Multichannel process display with graphics-capable LC display and datalogger
- CIT 700 / CIT 750** Multichannel process display with graphics-capable TFT monitor, touchscreen and contacts
- PA 440** Field display with 4-digit LC display



