



ILMK 458H

Probe with HART®-communication for Marine and Offshore

Ceramic Sensor

accuracy according to IEC 60770:
0.1 % FSO

Nominal pressure

from 0 ... 60 cmH₂O up to 0 ... 200 mH₂O

Output signals

2-wire: 4 ... 20 mA
others on request

Special characteristics

- ▶ shipping approvals acc. to:
 - Lloyd's Register (LR), Det Norske Veritas
 - Germanischer Lloyd (DNV•GL)
 - China Classification Society (CCS),
 - American Bureau of Shipping (ABS)
- ▶ diameter 39.5 mm
- ▶ HART® communication
(setting of offset, span and damping)
- ▶ high overpressure resistance
- ▶ high long-term stability



Optional versions

- ▶ IS-version
Ex ia = intrinsically safe for gas and dust
- ▶ diaphragm Al₂O₃ 99.9 %
- ▶ different housing materials
(stainless steel, CuNiFe)
- ▶ screw-in and flange version
- ▶ accessories e. g. assembling and
probe flange, mounting clamp

The hydrostatic probe ILMK 458H has been developed for measuring level in service and storage tanks and is certificated for shipbuilding and offshore applications.

A permissible operating temperature up to 85°C and the possibility to use the device in intrinsic safe areas enable to measure the pressure of various fluids under extreme conditions. The basis for the ILMK 458H is a self-developed capacitive ceramic sensor element, which offers a high overload resistance and medium compatibility.

Preferred areas of use are

-  Water
drinking water abstraction
desalinization plant
- Shipbuilding / Offshore
 ballast tanks
draught monitoring
level measurement in ballast and
storage tanks



ILMK 458H

Probe for Marine and Offshore

Technical Data

Pressure ranges								
Nominal pressure gauge ¹ [bar]	0.06	0.16	0.4	1	2	5	10	20
Level [mH ₂ O]	0.6	1.6	4	10	20	50	100	200
Overpressure [bar]	2	4	6	8	15	25	35	45
Max. ambient pressure (housing): 40 bar								
¹ on customer request we adjust the devices by software on the required pressure ranges, within the turn-down possibility (starting at 0.02 bar)								
Output signal / Supply								
Standard	2-wire: 4 ... 20 mA / V _S = 12 ... 36 V _{DC}	with HART® communication		V _{S rated} = 24 V _{DC}				
Option IS-version	2-wire: 4 ... 20 mA / V _S = 14 ... 28 V _{DC}	with HART® communication		V _{S rated} = 24 V _{DC}				
Performance								
Accuracy ²	p _N ≥ 160 mbar	TD ≤ 1:5	≤ ± 0.2 % FSO	TD _{max} = 1:10				
		TD > 1:5	≤ ± [0.2 + 0.03 x TD] % FSO					
	p _N < 160 mbar		≤ ± [0.2 + 0.1 x TD] % FSO	TD _{max} = 1:3				
	p _N ≥ 1 bar	TD ≤ 1:5	≤ ± 0.1 % FSO	TD _{max} = 1:10				
		TD > 1:5	≤ ± [0.1 + 0.02 x TD] % FSO					
Permissible load	R _{max} = [(V _S - V _{S min}) / 0.02 A] Ω		load at HART®-communication: R _{min} = 250 Ω					
Long term stability	≤ ± (0.1 x turn-down) FSO / year at reference conditions							
Influence effects	supply: 0.05 % FSO / 10 V permissible load: 0.05 % FSO / kΩ							
Turn-on time	850 msec							
Mean response time	140 msec without consideration of electronic damping		mean measuring rate 7/sec					
Max. response time	380 msec							
Adjustability	configuration of following parameters possible (interface / software necessary ³): electronic damping: 0 ... 100 sec offset: 0 ... 80 % FSO turn down of span: max. 1:10							
² accuracy according to IEC 60770 – limit point adjustment (non-linearity, hysteresis, repeatability)								
³ software, interface, and cable have to be ordered separately (software appropriate for Windows® 95, 98, 2000, NT Version 4.0 or higher, and XP)								
Thermal effects (offset and span) / Permissible temperatures								
Tolerance band	≤ ± 1 % FSO							
in compensated range	-20 ... 80 °C							
Permissible temperatures	medium / electronics / environment / storage: -25 ... 85 °C							
Electrical protection ⁴								
Short-circuit protection	permanent							
Reverse polarity protection	no damage, but also no function							
Electromagnetic compatibility	emission and immunity according to - EN 61326 - DNV•GL (Det Norske Veritas • Germanischer Lloyd)							
⁴ additional external overvoltage protection unit in terminal box KL 1 or KL 2 with atmospheric pressure reference available								
Mechanical stability								
Vibration	4 g (according to DNV•GL: class B, curve 2 / basis: DIN EN 60068-2-6)							
Electrical connection								
Cable with sheath material ⁵	TPE-U blue Ø 7.4 mm							
Bending radius	static installation: 10-fold cable diameter		dynamic application: 20-fold cable diameter					
⁵ shielded cable with integrated ventilation tube for atmospheric pressure reference (for nominal pressure ranges absolute and sealed gauge, the ventilation tube is closed)								
Materials (media wetted)								
Housing	standard: stainless steel 1.4404 (316L)		option: CuNi10Fe1Mn (resistant against sea water)					
Seals	standard: FKM		options: EPDM, FFKM (min. permissible temperature from -15 °C) others on request					
Diaphragm	standard: ceramics Al ₂ O ₃ 96 %		option: ceramics Al ₂ O ₃ 99.9 %					
Protection cap	POM-C							
Cable sheath	TPE-U (flame-resistant, halogen free, increased resistance against oil and gasoline, resistant against salt, sea water, heavy oil)							
Miscellaneous								
Option cable protection for probes in stainless steel	prepared for mounting with stainless steel pipe; available as compact product (standard: stainless steel pipe with a total length up to 2 m possible; other lengths on request)							
Ingress protection	IP 68							
Current consumption	max. 21 mA							
Weight	min. 650 g (without cable)							
CE-conformity	EMC Directive: 2014/30/EU							
ATEX Directive	2014/34/EU							
Category of the environment								
Lloyd's Register (LR)	EMV1, EMV2, EMV3, EMV4		number of certificate: 13/20056					
Det Norske Veritas • Germanischer Lloyd (DNV•GL)	temperature: D	vibration: B	number of certificate: TAA00001GM					
	humidity: B	enclosure: D						
	electromagnetic compatibility: B							
Explosion protection								
Approval DX15A-ILMK 458H	IBExU 10 ATEX 1186 X	zone 0 ⁶ : II 1G Ex ia IIB T4 Ga	zone 20: II 1D Ex ia IIIC T85 °C Da					
Safety technical maximum values	U _i = 28 V, I _i = 93 mA, P _i = 660 mW, C _i = 94,6 nF; L _i = 0 μH; the supply connections have an inner capacity of max. 110 nF opposite the enclosure							
Permissible temperatures for environment	in zone 0: -20 ... 60 °C with p _{atm} 0.8 bar up to 1.1 bar zone 1 and higher: -25 ... 70 °C							
Connecting cables (by factory)	cable capacity:	signal line/shield as well as signal line/signal line: 160 pF/m						
	cable inductance:	signal line/shield as well as signal line/signal line: 1 μH/m						
⁶ for optional stainless steel pipe the following designation is valid: "II 1G Ex ia IIC T4" (zone 0)								

ILMK 458H

Probe for Marine and Offshore

Technical Data

Wiring diagram

2-wire-system (current) HART®

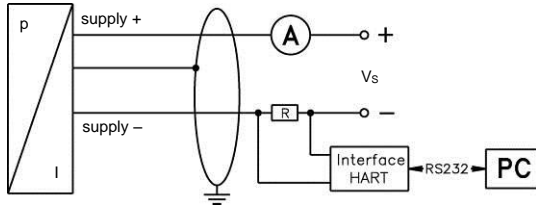

Pin configuration

Electrical connection	cable colours (IEC 60757)
Supply V_s +	WH (white)
Supply V_s -	BN (brown)
Shield	GNYE (green-yellow)

Dimensions for housing in stainless steel and CuNiFe (mm / in)

probe

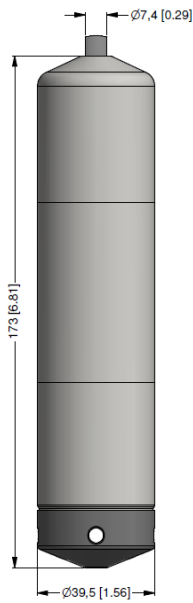

protection cap removable

option

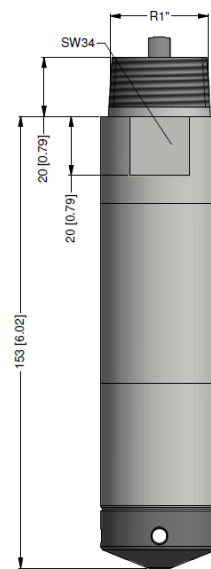

prepared for mounting with stainless steel pipe

screw-in version

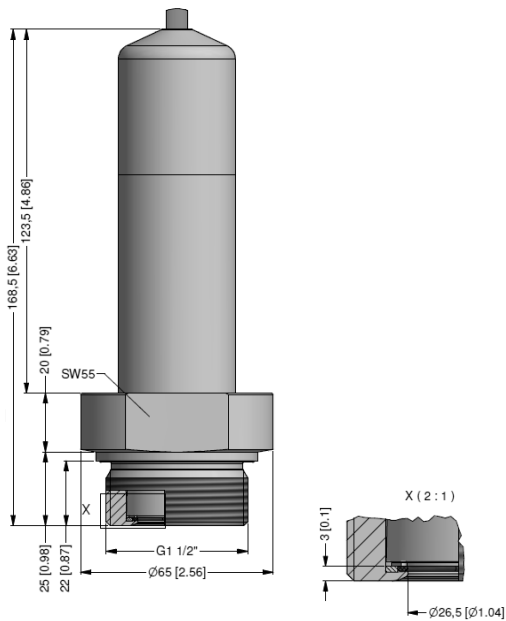

flange version

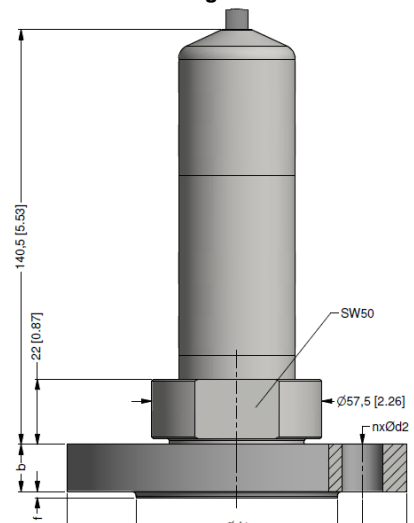

⇒ transmitter flange is not part of supply and has to be ordered separately

HART® is a registered trade mark of HART Communication Foundation; Windows® is a registered trade mark of Microsoft Corporation

ILMK 458H

Probe for Marine and Offshore

Accessories

Transmitter flange for flange version

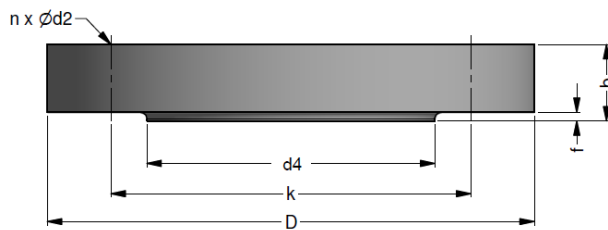

dimensions in mm			
size	DN25 / PN40	DN50 / PN40	DN80 / PN16
b	18	20	20
D	115	165	200
d2	14	18	18
d4	68	102	138
f	2	3	3
k	85	125	160
n	4	4	8

Technical data

Suitable for	ILMK 382, ILMK 382H, ILMK 458, ILMK 458H		
Flange material	stainless steel 1.4404 (316L)		
Hole pattern	according to DIN 2507		
Ordering type	Ordering code	Weight	
Transmitter flange DN25 / PN40	ZSF2540	1.2 kg	
Transmitter flange DN50 / PN40	ZSF5040	2.6 kg	
Transmitter flange DN80 / PN16	ZSF8016	4.1 kg	

Mounting flange with cable gland

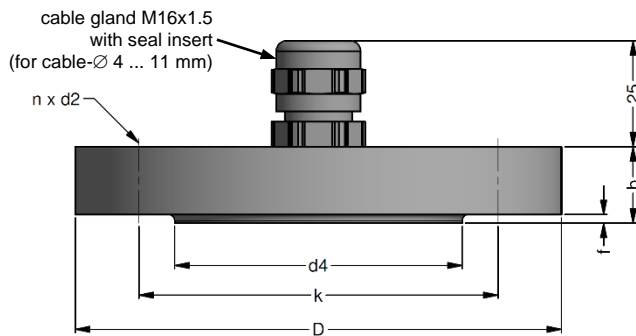

dimensions in mm			
size	DN25 / PN40	DN50 / PN40	DN80 / PN16
b	18	20	20
D	115	165	200
d2	14	18	18
d4	68	102	138
f	2	3	3
k	85	125	160
n	4	4	8

Technical data

Suitable for	all probes		
Flange material	stainless steel 1.4404 (316L)		
Material of cable gland	standard: brass, nickel plated on request: stainless steel 1.4305 (303); plastic		
Seal insert	material: TPE (ingress protection IP 68)		
Hole pattern	according to DIN 2507		
Ordering type	Ordering code	Weight	
DN25 / PN40 with cable gland brass, nickel plated	ZMF2540	1.4 kg	
DN50 / PN40 with cable gland brass, nickel plated	ZMF5040	3.2 kg	
DN80 / PN16 with cable gland brass, nickel plated	ZMF8016	4.8 kg	

