



ILMP 305

Slimline Probe

Stainless Steel Sensor

accuracy according to IEC 60770:
standard: 0.35 % FSO
option: 0.25 % FSO

Nominal pressure

from 0 ... 1 mH₂O up to 0 ... 250 mH₂O

Output signals

2-wire: 4 ... 20 mA
others on request

Special characteristics

- ▶ diameter 19 mm for confined space conditions e. g. in 1" pipes
- ▶ small thermal effect
- ▶ good long term stability
- ▶ excellent linearity

Optional versions

- ▶ different kinds of cable
- ▶ customer specific versions e. g. special pressure ranges

The slimline probe ILMP 305 with silicon stainless steel sensor is designed for continuous level measurement in confined space conditions e. g. 1" pipes. Permissible media are clean or lightly polluted water and thin fluids.

A piezoresistiv stainless steel sensor with low thermal error, an excellent linearity and a long term stability, is basis of ILMP 305.

Preferred areas of use are

Water

level measurement in confined space conditions



ground water monitoring

depth or level measurement in wells and open waters

drinking water system

level measurement in container



Input pressure range														
Nominal pressure gauge	[bar]	0.1	0.16	0.25	0.4	0.6	1	1.6	2.5	4	6	10	16	25
Level	[mH ₂ O]	1	1.6	2.5	4	6	10	16	25	40	60	100	160	250
Overpressure	[bar]	1	1	1	1	3	3	6	6	20	20	60	60	100
Max. ambient pressure (housing): 40 bar														

Output signal / Supply	
2-wire	4 ... 20 mA / V _S = 12 ... 36 V _{DC}
Performance	
Accuracy ¹	standard: nominal pressure > 0.4 bar: ≤ ± 0.35 % FSO nominal pressure ≤ 0.4 bar: ≤ ± 0.50 % FSO option: nominal pressure > 0.4 bar: ≤ ± 0.25 % FSO
Permissible load	R _{max} = [(V _S - V _{S min}) / 0,02 A] Ω
Influence effects	supply: 0.05 % FSO / 10 V load: 0.05 % FSO / kΩ
Long term stability	≤ ± 0.1 % FSO / year at reference conditions
Response time	≤ 10 msec

¹ accuracy according to IEC 60770 – limit point adjustment (non-linearity, hysteresis, repeatability)

Thermal effects (Offset and Span)						
Nominal pressure P _N	[bar]	≤ 0.1	≤ 0.25	≤ 0.4	≤ 1	> 1
Tolerance band	[% FSO]	≤ ± 2	≤ ± 1.5	≤ ± 1	≤ ± 1	≤ ± 0.75
TC, average	[% FSO / 10 K]	± 0.3	± 0.2	± 0.14	± 0.1	± 0.07
In compensated range	[°C]	0 ... 50			0 ... 70	

Permissible temperatures	
Permissible temperatures	medium: -10 ... 70 °C storage: -25 ... 70 °C

Electrical protection ²	
Short-circuit protection	permanent
Reverse polarity protection	no damage, but also no function
Electromagnetic compatibility	emission and immunity according to EN 61326

² additional external overvoltage protection unit in terminal box KL 1 or KL 2 with atmospheric pressure reference available on request

Electrical connection	
Cable with sheath material ³	PVC (-5 ... 70 °C) grey Ø 7.4 mm PUR (-10 ... 70 °C) black Ø 7.4 mm FEP ⁴ (-10 ... 70 °C) black Ø 7.4 mm
Cable capacitance	signal line/shield also signal line/signal line: 160 pF/m
Cable inductance	signal line/shield also signal line/signal line: 1 µH/m
Bending radius	static installation: 10-fold cable diameter dynamic application: 20-fold cable diameter

³ shielded cable with integrated ventilation tube for atmospheric pressure reference

⁴ do not use freely suspended probes with an FEP cable if effects due to highly charging processes are expected

Materials (media wetted)	
Housing	stainless steel 1.4404 (316L)
Seals	FKM, EPDM
Diaphragm	stainless steel 1.4435 (316L)
Protection cap	POM-C
Cable sheath	PVC, PUR, FEP, others on request

Miscellaneous	
Current consumption	max. 25 mA
Weight	approx. 100 g (without cable)
Ingress protection	IP 68
CE-conformity	EMC Directive: 2014/30/EU



ILMP 305

Slimline Probe

Technical Data

Pin configuration	
Electrical connection	cable colours (IEC 60757)
Supply +	WH (white)
Supply -	BN (brown)
Shield	GYE (green-yellow)

Dimensions (mm / in)	

protection cap removable

Mounting flange with cable gland

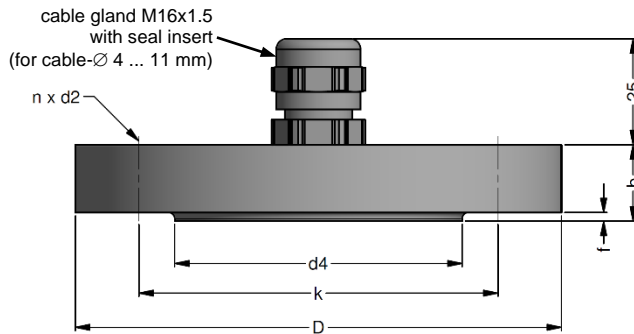

dimensions in mm			
size	DN25 / PN40	DN50 / PN40	DN80 / PN16
b	18	20	20
D	115	165	200
d2	14	18	18
d4	68	102	138
f	2	3	3
k	85	125	160
n	4	4	8

Technical data

Suitable for	all probes		
Flange material	stainless steel 1.4404 (316L)		
Material of cable gland	standard: brass, nickel plated on request: stainless steel 1.4305 (303); plastic		
Seal insert	material: TPE (ingress protection IP 68)		
Hole pattern	according to DIN 2507		
Ordering type	Ordering code	Weight	
DN25 / PN40 with cable gland brass, nickel plated	ZMF2540	1.4 kg	
DN50 / PN40 with cable gland brass, nickel plated	ZMF5040	3.2 kg	
DN80 / PN16 with cable gland brass, nickel plated	ZMF8016	4.8 kg	

Terminal clamp



Technical data

Suitable for	all probes with cable \varnothing 5.5 ... 10.5 mm		
Material of housing	standard: steel, zinc plated optionally: stainless steel 1.4301 (304)		
Material of clamping jaws and positioning clips	PA (fibre-glass reinforced)		
Dimensions (mm)	174 x 45 x 32		
Hook diameter	20 mm		
Ordering type	Ordering code	Weight	
Terminal clamp, steel, zinc plated	Z100528	approx. 160 g	
Terminal clamp, stainless steel 1.4301 (304)	Z100527		

Display program

- CIT 200** Process display with LED display
- CIT 250** Process display with LED display and contacts
- CIT 300** Process display with LED display, contacts and analogue output
- CIT 350** Process display with LED display, bargraph, contacts and analogue output
- CIT 400** Process display with LED display, contacts, analogue output and Ex-approval
- CIT 600** Multichannel process display with graphics-capable LC display
- CIT 650** Multichannel process display with graphics-capable LC display and datalogger
- CIT 700 / CIT 750** Multichannel process display with graphics-capable TFT monitor, touchscreen and contacts
- PA 440** Field display with 4-digit LC display



Ordering code ILMP 305

ILMP 305

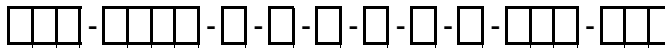

Pressure																					
	in bar	4	0	0																	
	in mH ₂ O	4	0	1																	
Input		[mH ₂ O]	[bar]																		
	1.0	0.10		1	0	0	0														
	1.6	0.16		1	6	0	0														
	2.5	0.25		2	5	0	0														
	4.0	0.40		4	0	0	0														
	6.0	0.60		6	0	0	0														
	10	1.0		1	0	0	1														
	16	1.6		1	6	0	1														
	25	2.5		2	5	0	1														
	40	4.0		4	0	0	1														
	60	6.0		6	0	0	1														
	100	10		1	0	0	2														
	160	16		1	6	0	2														
	250	25		2	5	0	2														
	customer			9	9	9	9													consult	
Housing																					
	stainless steel 1.4404 (316L)						1														
	customer						9														consult
Diaphragm																					
	stainless steel 1.4435 (316L)						1														
	customer						9														consult
Output																					
	4 ... 20 mA / 2-wire						1														
	customer						9														consult
Seals																					
	FKM						1														
	EPDM						3														
	customer						9														consult
Accuracy																					
	standard for P _N > 0.4 bar	0.35 % FSO					3														
	standard for P _N ≤ 0.4 bar	0.5 % FSO					5														
	option for P _N > 0.4 bar	0.25 % FSO					2														
	customer						9														consult
Electrical connection																					
	PVC-cable (grey, Ø 7.4 mm) ¹												1								
	PUR-cable (black, Ø 7.4 mm) ¹												2								
	FEP-cable (black, Ø 7.4 mm) ¹												3								
	customer												9								consult
Cable length																					
	in m												9	9	9						
Special version																					
	standard																				0 0 0
	customer																				9 9 9
																					consult

¹ shielded cable with integrated ventilation tube for atmospheric pressure reference