



ILMP 307i

Stainless Steel Probe

Stainless Steel Sensor

accuracy according to IEC 60770:
0.1 % FSO

Nominal pressure

from 0 ... 4 mH₂O up to 0 ... 200 mH₂O

Output signals

2-wire: 4 ... 20 mA
3-wire: 0 ... 10 V
others on request

Special characteristics

- ▶ diameter 26.5 mm
- ▶ small thermal effect
- ▶ excellent accuracy
- ▶ excellent long term stability

Optional versions

- ▶ IS-version
Ex ia = intrinsically safe for gas and dust
- ▶ drinking water certificate
according to DVGW and KTW
- ▶ different kinds of cables
and elastomers

The stainless steel probe ILMP 307i is designed for continuous level measurement in water and clean or lightly polluted fluids.

Basic element is a high quality stainless steel sensor with high requirements for exact measurement with good long term stability.

Preferred areas of use are

Water / filtrated sewage

drinking water systems
ground water level measurement
rain spillway basins
pump and booster stations
level measurement in containers
water treatment plants
water recycling



Fuel and oil

fuel storage
tank farms



Input pressure range ¹							
Nominal pressure gauge	[bar]	0.40	1	2	4	10	20
Level	[mH ₂ O]	4	10	20	40	100	200
Overpressure	[bar]	2	5	10	20	40	80
Burst pressure ≥	[bar]	3	7.5	15	25	50	120
Max. ambient pressure (housing): 40 bar							
¹ On customer request we adjust the device within the turn-down-possibility by software on the required pressure range.							

Output signal / Supply	
Standard	2-wire: 4 ... 20 mA / V _S = 12 ... 36 V _{DC}
Option IS-version	2-wire: 4 ... 20 mA / V _S = 14 ... 28 V _{DC}
Options 3-wire	3-wire: 0 ... 10 V / V _S = 14 ... 36 V _{DC}
Performance	
Accuracy ²	nominal pressure ≥ 0.1 bar: ≤ ± 0.1 % FSO nominal pressure < 0.1 bar: ≤ ± 0.2 % FSO
Permissible load	current 2-wire: R _{max} = [(V _S - V _{S min}) / 0.02 A] Ω voltage 3-wire: R _{min} = 10 kΩ
Influence effects	supply: 0.05 % FSO / 10 V load: 0.05 % FSO / kΩ
Long term stability	≤ ± 0.1 % FSO / year at reference conditions
Response time	ca. 200 msec

² accuracy according to IEC 60770 – limit point adjustment (non-linearity, hysteresis, repeatability)

Thermal effects (offset and span)	
Tolerance band	≤ ± 0.2 % FSO in compensated range -20 ... 80°C
TC	± 0.02 % FSO / 10K in compensated range -20 ... 80°C

Permissible temperatures	
Permissible temperatures	medium: -10 ... 70 °C storage: -25 ... 70 °C

Electrical protection ³	
Insulation resistance	> 100 MΩ
Reverse polarity protection	no damage, but also no function
Electromagnetic compatibility	emission and immunity according to EN 61326

³ additional external overvoltage protection unit in terminal box KL 1 or KL 2 with atmospheric pressure reference available on request

Electrical connection	
Cable with sheath material ⁴	PVC (-5 ... 70 °C) grey Ø 7.4 mm PUR (-10 ... 70 °C) black Ø 7.4 mm FEP ⁵ (-10 ... 70 °C) black Ø 7.4 mm TPE-U (-10 ... 70 °C) blue Ø 7.4 mm (without/with drinking water certificate)
Bending radius	static installation: 10-fold cable diameter dynamic application: 20-fold cable diameter

⁴ shielded cable with integrated ventilation tube for atmospheric pressure reference

⁵ do not use freely suspended probes with an FEP cable if effects due to highly charging processes are expected

Materials (media wetted)	
Housing	stainless steel 1.4404 (316L)
Seals	FKM EPDM (without/with drinking water certificate) others on request
Diaphragm	stainless steel 1.4435 (316L)
Protection cap	POM-C
Cable sheath	PVC, PUR, FEP, TPE-U

Explosion protection (only for 4 ... 20 mA / 2-wire)	
Approvals DX19-ILMP 307i	IBExU 10 ATEX 1068 X / IECEx IBE 12.0027X zone 0: II 1G Ex ia IIC T4 Ga zone 20: II 1D Ex ia IIIC T135 °C Da
Safety technical maximum values	U _i = 28 V, I _i = 93 mA, P _i = 660 mW, C _i ≈ 0 nF, L _i ≈ 0 μH, the supply connections have an inner capacity of max. 27 nF to the housing
Permissible temperatures for environment	in zone 0: -20 ... 60 °C with p _{atm} 0.8 bar up to 1.1 bar in zone 1 or higher: -40/-20 ... 65 °C
Connecting cables (by factory)	cable capacitance: signal line/shield also signal line/signal line: 160 pF/m cable inductance: signal line/shield also signal line/signal line: 1 μH/m

ILMP 307i

Stainless Steel Probe

Technical Data

Miscellaneous	
Drinking water certificate ⁶	according to DVGW W 270 and UBA KTW (with order the indication "with drinking water certificate" is necessary)
Current consumption	signal output current: max. 25 mA signal output voltage: max. 7 mA
Weight	approx. 200 g (without cable)
Ingress protection	IP 68
CE-conformity	EMC Directive: 2014/30/EU
ATEX Directive	2014/34/EU

⁶ only possible with EPDM seal in combination with TPE-U cable; not possible with IS-version (explosion protection)

Wiring diagrams

2-wire-system (current)

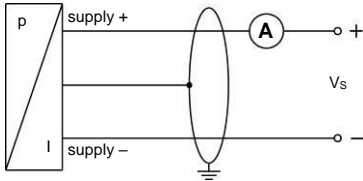

3-wire-system (current / voltage)

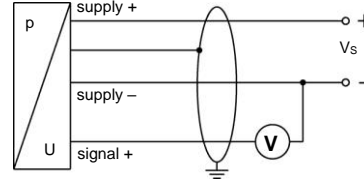

Pin configuration

Electrical connection	cable colours (IEC 60757)
Supply +	WH (white)
Supply -	BN (brown)
Signal + (only 3-wire)	GN (green)
Shield	GNYE (green-yellow)

Dimensions (mm / in)

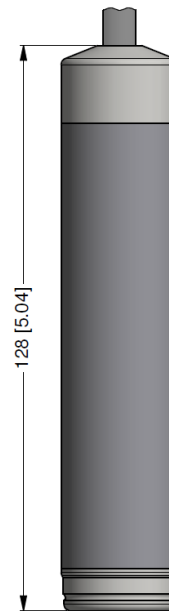
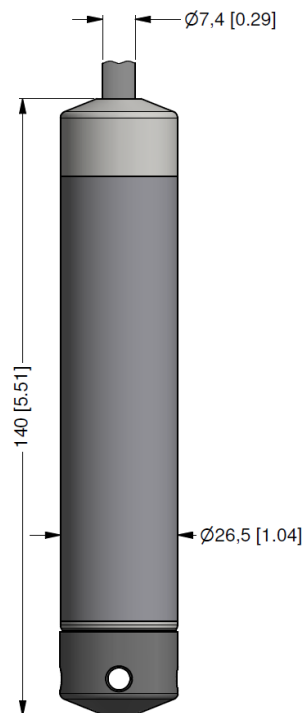

protection cap removable

Mounting flange with cable gland

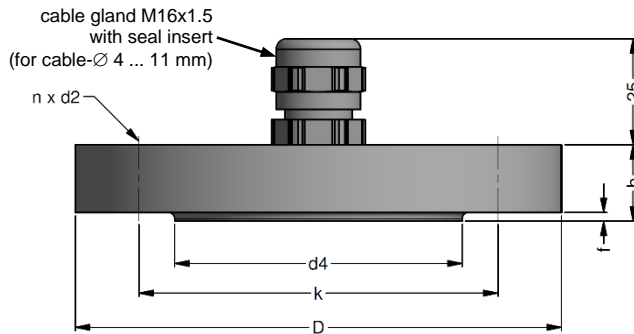

dimensions in mm			
size	DN25 / PN40	DN50 / PN40	DN80 / PN16
b	18	20	20
D	115	165	200
d2	14	18	18
d4	68	102	138
f	2	3	3
k	85	125	160
n	4	4	8

Technical data		
Suitable for	all probes	
Flange material	stainless steel 1.4404 (316L)	
Material of cable gland	standard: brass, nickel plated on request: stainless steel 1.4305 (303); plastic	
Seal insert	material: TPE (ingress protection IP 68)	
Hole pattern	according to DIN 2507	
Ordering type	Ordering code	Weight
DN25 / PN40 with cable gland brass, nickel plated	ZMF2540	1.4 kg
DN50 / PN40 with cable gland brass, nickel plated	ZMF5040	3.2 kg
DN80 / PN16 with cable gland brass, nickel plated	ZMF8016	4.8 kg

Terminal clamp



Technical data		
Suitable for	all probes with cable Ø 5.5 ... 10.5 mm	
Material of housing	standard: steel, zinc plated optionally: stainless steel 1.4301 (304)	
Material of clamping jaws and positioning clips	PA (fibre-glass reinforced)	
Dimensions (mm)	174 x 45 x 32	
Hook diameter	20 mm	
Ordering type	Ordering code	Weight
Terminal clamp, steel, zinc plated	Z100528	approx. 160 g
Terminal clamp, stainless steel 1.4301 (304)	Z100527	

Display program

- CIT 200** Process display with LED display
- CIT 250** Process display with LED display and contacts
- CIT 300** Process display with LED display, contacts and analogue output
- CIT 350** Process display with LED display, bargraph, contacts and analogue output
- CIT 400** Process display with LED display, contacts, analogue output and Ex-approval
- CIT 600** Multichannel process display with graphics-capable LC display
- CIT 650** Multichannel process display with graphics-capable LC display and datalogger
- CIT 700 / CIT 750** Multichannel process display with graphics-capable TFT monitor, touchscreen and contacts
- PA 440** Field display with 4-digit LC display



