



ILMP 308

Detachable Stainless Steel Probe

Stainless Steel Sensor

accuracy according to IEC 60770:
standard: 0.35 % FSO
option: 0.25 % FSO / 0.1 % FSO

Nominal pressure

from 0 ... 1 mH₂O up to 0 ... 250 mH₂O

Output signals

2-wire: 4 ... 20 mA
others on request

Special characteristics

- ▶ diameter 35 mm
- ▶ cable and sensor head detachable
- ▶ high accuracy
- ▶ good long term stability

Optional versions

- ▶ IS-version
Ex ia = intrinsically safe for gas and dust
- ▶ SIL 2 (Safety Integrity Level)
- ▶ customer specific versions
- ▶ mounting accessories e.g.
mounting flange and terminal clamp
in stainless steel
- ▶ different kinds of cables
and elastomers

The detachable stainless steel probe ILMP 308 is designed for the continuous level measurement of water and low-viscosity fluids.

In order to facilitate stock-keeping and maintenance the sensor head is plugged to the cable assembly with a connector and can be changed easily.

Preferred areas of use are

Water / filtrated sewage

ground water level measurement

level measurement in wells and open waters



rain spillway basin

level measurement in container

water treatment plants

water recycling



ILMP 308

Detachable Stainless Steel Probe

Technical Data

Input pressure range															
Nominal pressure gauge	[bar]	0.10	0.16	0.25	0.40	0.60	1	1.6	2.5	4	6	10	16	25	
Level	[mH ₂ O]	1	1.6	2.5	4	6	10	16	25	40	60	100	160	250	
Overpressure	[bar]	0.5	1	1	2	5	5	10	10	20	40	40	80	80	
Burst pressure	[bar]	1.5	1.5	1.5	3	7.5	7.5	15	15	25	50	50	120	120	
Max. ambient pressure (housing): 40 bar															
Output signal / Supply															
Standard		2-wire:	4 ... 20 mA / V _S = 8 ... 32 V _{DC}					SIL-version: V _S = 14 ... 28 V _{DC}							
Option IS-protection		2-wire:	4 ... 20 mA / V _S = 10 ... 28 V _{DC}					SIL-version: V _S = 14 ... 28 V _{DC}							
Performance															
Accuracy ¹		standard:	nominal pressure < 0.4 bar:		≤ ± 0.5 % FSO										
			nominal pressure ≥ 0.4 bar:		≤ ± 0.35 % FSO										
		option 1:	nominal pressure ≥ 0.4 bar:		≤ ± 0.25 % FSO										
		option 2:	for all nominal pressures:		≤ ± 0.1 % FSO										
Permissible load		$R_{max} = [(V_S - V_{S_{min}}) / 0.02 A] \Omega$													
Influence effects		supply:	0.05 % FSO / 10 V					load: 0.05 % FSO / k Ω							
Long term stability		≤ ± 0.1 % FSO / year at reference conditions													
Response time		≤ 10 msec													
¹ accuracy according to IEC 60770 – limit point adjustment (non-linearity, hysteresis, repeatability)															
Thermal effects (Offset and Span)															
Nominal pressure p _N	[bar]	< 0.40					≥ 0.40								
Tolerance band	[% FSO]	≤ ± 1					≤ ± 0.75								
in compensated range	[°C]	0 ... 70													
Permissible temperatures															
Permissible temperatures		medium: -20 ... 70 °C					storage: -25 ... 70 °C								
Electrical protection ²															
Short-circuit protection		permanent													
Reverse polarity protection		no damage, but also no function													
Lightning protection		integrated													
Electromagnetic compatibility		emission and immunity according to EN 61326													
² additional external overvoltage protection unit in terminal box KL 1 or KL 2 with atmospheric pressure reference available on request															
Electrical connection															
Cable with sheath material ³		PVC (-5 ... 70 °C) grey Ø 7.4 mm PUR (-20 ... 70 °C) black Ø 7.4 mm FEP ⁴ (-20 ... 70 °C) black Ø 7.4 mm													
Bending radius		static installation: 10-fold cable diameter dynamic application: 20-fold cable diameter													
³ shielded cable with integrated ventilation tube for atmospheric pressure reference															
⁴ do not use freely suspended probes with an FEP cable if effects due to highly charging processes are expected															
Materials (media wetted)															
Housing		stainless steel 1.4404 (316L)													
Seals		FKM, EPDM, others on request													
Diaphragm		stainless steel 1.4435 (316L)													
Protection cap		POM-C													
Cable sheath		PVC, PUR, FEP, others on request													
Explosion protection															
Approvals DX19-ILMP 308		IBExU 10 ATEX 1068 X / IECEx IBE 12.0027X zone 0: II 1G Ex ia IIC T4 Ga zone 20: II 1D Ex ia IIIC T135 °C Da													
Safety technical maximum values		U _i = 28 V, I _i = 93 mA, P _i = 660 mW, C _i ≈ 0nF, L _i ≈ 0μH, the supply connections have an inner capacity of max. 27 nF to the housing													
Permissible temperatures for environment		in zone 0: -20 ... 60 °C with p _{atm} 0.8 bar up to 1.1 bar in zone 1 or higher: -40/-20 ... 70 °C													
Connecting cables (by factory)		cable capacitance: signal line/shield also signal line/signal line: 160 pF/m cable inductance: signal line/shield also signal line/signal line: 1 μH/m													
Miscellaneous															
Option SIL2 version ⁵		according to IEC 61508 / IEC 61511													
Current consumption		max. 25 mA													
Weight		approx. 250 g (without cable)													
Ingress protection		IP 68													
CE-conformity		EMC Directive: 2014/30/EU													
ATEX Directive		2014/34/EU													
⁵ not in combination with the accuracy 0.1 % FSO															

ILMP 308

Detachable Stainless Steel Probe

Technical Data

Wiring diagram

2-wire-system (current)

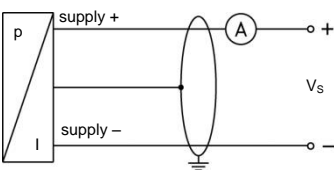

connector

A-A

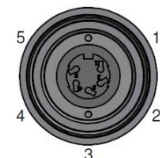

B-B

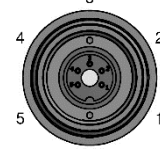

Pin configuration

Electrical connection	Binder series 723 ⁶ (5-pin)	cable colours (IEC 60757)
Supply +	3	WH (white)
Supply -	1	BN (brown)
Shield	5	GNYE (green-yellow)

⁶ if detached

Dimensions (mm / in)

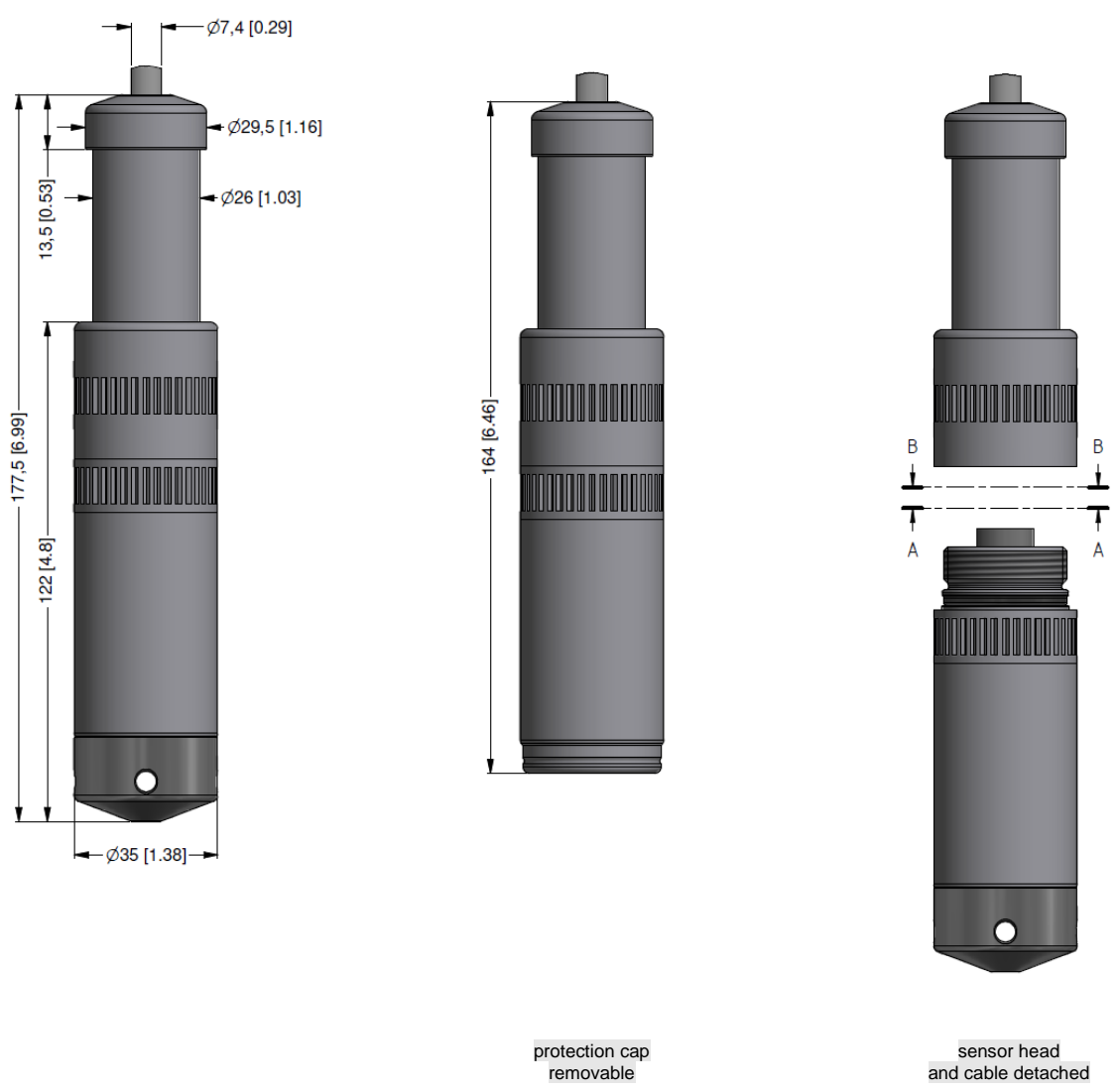

protection cap removable

sensor head and cable detached

ILMP 308

Detachable Stainless Steel Probe

Accessories

Mounting flange with cable gland

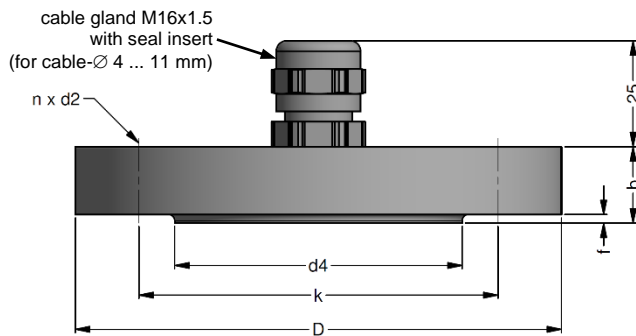

dimensions in mm			
size	DN25 / PN40	DN50 / PN40	DN80 / PN16
b	18	20	20
D	115	165	200
d2	14	18	18
d4	68	102	138
f	2	3	3
k	85	125	160
n	4	4	8

Technical data		
Suitable for	all probes	
Flange material	stainless steel 1.4404 (316L)	
Material of cable gland	standard: brass, nickel plated on request: stainless steel 1.4305 (303); plastic	
Seal insert	material: TPE (ingress protection IP 68)	
Hole pattern	according to DIN 2507	
Ordering type	Ordering code	Weight
DN25 / PN40 with cable gland brass, nickel plated	ZMF2540	1.4 kg
DN50 / PN40 with cable gland brass, nickel plated	ZMF5040	3.2 kg
DN80 / PN16 with cable gland brass, nickel plated	ZMF8016	4.8 kg

Terminal clamp



Technical data		
Suitable for	all probes with cable Ø 5.5 ... 10.5 mm	
Material of housing	standard: steel, zinc plated optionally: stainless steel 1.4301 (304)	
Material of clamping jaws and positioning clips	PA (fibre-glass reinforced)	
Dimensions (mm)	174 x 45 x 32	
Hook diameter	20 mm	
Ordering type	Ordering code	Weight
Terminal clamp, steel, zinc plated	Z100528	approx. 160 g
Terminal clamp, stainless steel 1.4301 (304)	Z100527	

Display program

- CIT 200** Process display with LED display
- CIT 250** Process display with LED display and contacts
- CIT 300** Process display with LED display, contacts and analogue output
- CIT 350** Process display with LED display, bargraph, contacts and analogue output
- CIT 400** Process display with LED display, contacts, analogue output and Ex-approval
- CIT 600** Multichannel process display with graphics-capable LC display
- CIT 650** Multichannel process display with graphics-capable LC display and datalogger
- CIT 700 / CIT 750** Multichannel process display with graphics-capable TFT monitor, touchscreen and contacts
- PA 440** Field display with 4-digit LC display



Ordering code ILMP 308

ILMP 308



Pressure										
	in bar	4	4	0						
	in mH ₂ O	4	4	1						
Input										
	[mH ₂ O]	[bar]								
	1.0	0.10	1	0	0	0				
	1.6	0.16	1	6	0	0				
	2.5	0.25	2	5	0	0				
	4.0	0.40	4	0	0	0				
	6.0	0.60	6	0	0	0				
	10	1.0	1	0	0	1				
	16	1.6	1	6	0	1				
	25	2.5	2	5	0	1				
	40	4.0	4	0	0	1				
	60	6.0	6	0	0	1				
	100	10	1	0	0	2				
	160	16	1	6	0	2				
	250	25	2	5	0	2				
	customer		9	9	9	9				consult
Housing										
	stainless steel 1.4404 (316L)					1				
	customer					9				consult
Diaphragm										
	stainless steel 1.4435 (316L)					1				
	customer					9				consult
Output										
	4 ... 20 mA / 2-wire								1	
	intrinsic safety 4 ... 20 mA / 2-wire								E	
	SIL2 4 ... 20 mA / 2-wire								1S	
	SIL2 with intrinsic safety								ES	
	4 ... 20 mA / 2-wire									
	customer								9	consult
Seals										
	FKM								1	
	EPDM								3	
	customer								9	consult
Electrical connection										
	PVC-cable (grey, Ø 7.4 mm) ¹								1	
	PUR-cable (black, Ø 7.4 mm) ¹								2	
	FEP-cable (black, Ø 7.4 mm) ¹								3	
	customer								9	consult
Accuracy										
	standard for p _N ≥ 0.4 bar	0.35 % FSO							3	
	standard for p _N < 0.4 bar	0.5 % FSO							5	
	option 1 for p _N ≥ 0.4 bar	0.25 % FSO							2	
	option 2	0.1 % FSO ²							1	
	customer								9	consult
Cable length										
	in m								9	9
Version										
	standard								0	0
	customer								9	9
										consult

¹ cable with integrated ventilation tube for atmospheric pressure reference

² not in combination with SIL