



ILMP 308i

Detachable Stainless Steel Probe Precision

Stainless Steel Sensor

accuracy according to IEC 60770:
0.1 % FSO

Nominal pressure

from 0 ... 4 mH₂O up to 0 ... 200 mH₂O

Output signals

2-wire: 4 ... 20 mA
3-wire: 0 ... 10 V
others on request

Special characteristics

- ▶ diameter 35 mm
- ▶ cable assembly and sensor head detachable
- ▶ excellent accuracy
- ▶ communication interface
- ▶ thermal error in compensated range
-20 ... 70 °C: 0.2 % FSO
TC 0.02 % FSO / 10K
- ▶ Turn-Down 1:10

Optional versions

- ▶ IS-version
Ex ia = intrinsically safe for gas and dust
- ▶ mounting accessories
e.g. mounting flange and terminal clamp in stainless steel
- ▶ different kinds of cables and elastomers

The detachable precision stainless steel probe ILMP 308i is designed for continuous level measurement in water and low-viscosity fluids. The signal processing of sensor signal is done by digital electronics with 16-bit analogue digital converter. Consequently, it is possible to conduct an active compensation of sensor intrinsic deviations from normal conditions like nonlinearity and thermal error.

In order to facilitate stock-keeping and maintenance the sensor head is plugged to the cable assembly with a connector and can be changed easily.

Preferred areas of use are

Water / filtrated sewage

ground water level measurement
level measurement in wells
and open waters



rain spillway basins
level measurement in containers
water treatment plants
water recycling



ILMP 308i

Detachable Precision Stainless Steel Probe

Technical Data

Input pressure range ¹							
Nominal pressure gauge	[bar]	0.40	1	2	4	10	20
Level	[mH ₂ O]	4	10	20	40	100	200
Overpressure	[bar]	2	5	10	20	40	80
Burst pressure	[bar]	3	7.5	15	25	50	120
Max. ambient pressure (housing): 40 bar							
¹ On customer request we adjust the device within the turn-down-possibility by software on the required pressure range.							
Output signal / Supply							
Standard	2-wire: 4 ... 20 mA / V _S = 12 ... 36 V _{DC}						
Option IS-version	2-wire: 4 ... 20 mA / V _S = 14 ... 28 V _{DC}						
Options	2-wire: 4 ... 20 mA / V _S = 12 ... 36 V _{DC}			with communication interface			
	3-wire: 0 ... 10 V / V _S = 14 ... 36 V _{DC}			with communication interface			
Performance							
Accuracy	IEC 60770 ² : ≤ ± 0.1 % FSO						
Performance after turn-down (TD)	no change of accuracy ³ formula for accuracy calculating (for nominal pressure gauge ≤ 0.40 bar see note 3): ≤ ± [0.1 + 0.015 x turn-down] % FSO with turn-down = nominal pressure range / adjusted range e.g. following accuracy can be calculated for turn-down 1:10: ≤ ± (0.1 + 0.015 x 10) % FSO i.e. the accuracy is ≤ ± 0.25 % FSO						
Permissible load	current 2-wire: R _{max} = [(V _S - V _{S min}) / 0.02 A] Ω			voltage 3-wire: R _{min} = 10 kΩ			
Influence effects	supply: 0.05 % FSO / 10 V			load: 0.05 % FSO / kΩ			
Long term stability	≤ ± (0.1 x turn-down) % FSO / year at reference conditions						
Response time	ca. 200 msec						
Adjustability (with option communication interface)	following parameters can be adjusted (interface / software needed ⁴) electronic damping: 0 ... 100 sec offset: 0 ... 90 % FSO turn-down of span: max. 1:10						
² accuracy according to IEC 60770 – limit point adjustment (non-linearity, hysteresis, repeatability)							
³ nominal pressure gauges ≤ 0.40 bar are excluded; for these the calculation of accuracy is as follows: ≤ ± (0.1 + 0.02 x turn-down) % FSO e.g. turn-down 1:3: ≤ ± (0.1 + 0.02 x 3) % FSO i.e. the accuracy is ≤ ± 0.16 % FSO							
⁴ software, interface and cable must separate be ordered (software is compatible with Windows® 95, 98, 2000, NT from version 4.0 or higher and XP)							
Thermal effects (offset and span)							
Tolerance band	[% FSO]	≤ ± (0.2 x turn-down)		in compensated range -20 ... 70 °C			
TC	[% FSO / 10 K]	± (0.2 x turn-down)		in compensated range -20 ... 70 °C			
Permissible temperatures		medium: -20 ... 70 °C		storage: -25 ... 70 °C		electronics / environment: -25 ... 65 °C	
Electrical protection ⁵							
Short-circuit protection	permanent						
Reverse polarity protection	no damage, but also no function						
Lightning protection	2-wire: integrated			3-wire: without			
Electromagnetic compatibility	emission and immunity according to EN 61326						
⁵ additional external overvoltage protection unit in terminal box KL 1 or KL 2 with atmospheric pressure reference available on request							
Electrical connection							
Cable with sheath material ⁶	PVC (-5 ... 70 °C) grey Ø 7.4 mm PUR (-20 ... 70 °C) black Ø 7.4 mm FEP ⁷ (-20 ... 70 °C) black Ø 7.4 mm						
Bending radius	static installation: 10-fold cable diameter dynamic application: 20-fold cable diameter						
⁶ shielded cable with integrated ventilation tube for atmospheric pressure reference							
⁷ do not use freely suspended probes with an FEP cable if effects due to highly charging processes are expected							
Materials (media wetted)							
Housing	stainless steel 1.4404 (316L)						
Seals	FKM, EPDM, others on request						
Diaphragm	stainless steel 1.4435 (316L)						
Protection cap	POM-C						
Cable sheath	PVC, PUR, FEP, others on request						
Explosion protection (only for 4 ... 20 mA / 2-wire)							
Approvals DX19-ILMP 308 i	IBExU 10 ATEX 1068 X / IECEx IBE 12.0027X zone 0: II 1G Ex ia IIC T4 Ga zone 20: II 1D Ex ia IIIC T135 °C Da						
Safety technical maximum values	U _i = 28 V, I _i = 93 mA, P _i = 660 mW, C _i ≈ 0 nF, L _i ≈ 0 μH, the supply connections have an inner capacity of max. 27 nF to the housing						
Permissible temperatures for environment	in zone 0: -20 ... 60 °C with p _{atm} 0.8 bar up to 1.1 bar in zone 1 or higher: -40/-20 ... 65 °C						
Connecting cables (by factory)	cable capacitance: signal line/shield also signal line/signal line: 160 pF/m cable inductance: signal line/shield also signal line/signal line: 1 μH/m						

ILMP 308i

Detachable Precision Stainless Steel Probe

Technical Data

Miscellaneous					
Current consumption	max. 25 mA				
Weight	approx. 250 g (without cable)				
Ingress protection	IP 68				
CE-conformity / ATEX Directive	EMC Directive: 2014/30/EU		ATEX Directive: 2014/34/EU		
Wiring diagram / connector					
2-wire-system (current)		3-wire-system (voltage)			
Pin configuration					
Electrical connection	Binder series 723 ⁸ (5-pin)		Binder series 723 ⁸ (7-pin)		cable colours (IEC 60757)
		2-wire	3-wire	with communication interface	
Supply +		3	3	3 / WH (white)	WH (white)
Supply -		1	4	1 / BN (brown)	BN (brown)
Signal + (for 3-wire)		-	1	6 / GN (green)	GN (green)
RxD		-	-	4 / YE (yellow)	-
TxD		-	-	5 / GY (grey)	-
GND		-	-	7 / GN (green)	-
Shield		5	5	2 / GNYE (green-yellow)	GNYE (green-yellow)
⁸ if detached					
Dimensions (mm / in)					
			protection cap removable		
			sensor head and cable detached		

Mounting flange with cable gland

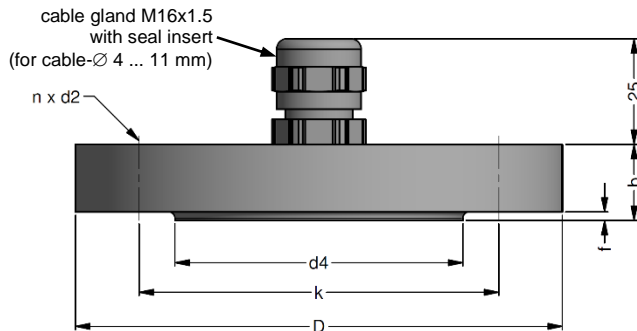

dimensions in mm			
size	DN25 / PN40	DN50 / PN40	DN80 / PN16
b	18	20	20
D	115	165	200
d2	14	18	18
d4	68	102	138
f	2	3	3
k	85	125	160
n	4	4	8

Technical data

Suitable for	all probes		
Flange material	stainless steel 1.4404 (316L)		
Material of cable gland	standard: brass, nickel plated on request: stainless steel 1.4305 (303); plastic		
Seal insert	material: TPE (ingress protection IP 68)		
Hole pattern	according to DIN 2507		
Ordering type	Ordering code	Weight	
DN25 / PN40 with cable gland brass, nickel plated	ZMF2540	1.4 kg	
DN50 / PN40 with cable gland brass, nickel plated	ZMF5040	3.2 kg	
DN80 / PN16 with cable gland brass, nickel plated	ZMF8016	4.8 kg	

Terminal clamp



Technical data

Suitable for	all probes with cable Ø 5.5 ... 10.5 mm		
Material of housing	standard: steel, zinc plated optionally: stainless steel 1.4301 (304)		
Material of clamping jaws and positioning clips	PA (fibre-glass reinforced)		
Dimensions (mm)	174 x 45 x 32		
Hook diameter	20 mm		
Ordering type	Ordering code	Weight	
Terminal clamp, steel, zinc plated	Z100528	approx. 160 g	
Terminal clamp, stainless steel 1.4301 (304)	Z100527		

Display program

CIT 200	Process display with LED display
CIT 250	Process display with LED display and contacts
CIT 300	Process display with LED display, contacts and analogue output
CIT 350	Process display with LED display, bargraph, contacts and analogue output
CIT 400	Process display with LED display, contacts, analogue output and Ex-approval
CIT 600	Multichannel process display with graphics-capable LC display
CIT 650	Multichannel process display with graphics-capable LC display and datalogger
CIT 700 / CIT 750	Multichannel process display with graphics-capable TFT monitor, touchscreen and contacts
PA 440	Field display with 4-digit LC display



