



IMK 387

Pressure Transmitter

Ceramic sensor

accuracy according to IEC 60770:
standard: 0.35 % FSO
option: 0.25 % FSO

Nominal pressure

from 0 ... 100 mbar up to 0 ... 60 bar

Output signal

2-wire: 4 ... 20 mA

3-wire and others on request

Product characteristics

- ▶ diaphragm
ceramics 99.9 % Al₂O₃
- ▶ high long-term stability





Optional versions

- ▶ IS-version
Ex ia = intrinsically safe for
gases and dust
- ▶ different kinds of inch threads
- ▶ pressure port in PVDF or PP-HT
for aggressive media

The pressure transmitter IMK 387 has been specially designed for applications in plant and machine engineering as well as laboratory techniques and is suitable for measuring small system pressure and filling heights.

By using our own-developed capacitive sensor, available in Al₂O₃ 99.9%, the IMK 387 offers a high overpressure resistance and a high temperature and media resistance. The pressure transmitter is available in an intrinsically safe version for usage in explosive environments.

Preferred areas of use

-  Plant and machine engineering
-  Laboratory techniques
-  Water
-  Aggressive media



Input pressure range																
Nominal pressure gauge	[bar]	0.1	0.16	0.25	0.4	0.6	1	1.6	2.5	4	6	10	16	25	40	60
Level	[mH ₂ O]	1	1.6	2.5	4	6	10	16	25	40	60	100	160	250	400	600
Overpressure	[bar]	3	4	5	5	5	7	7	12	12	20	20	20	40	70	70
Burst pressure ≥	[bar]	4	6	8	8	7	9	9	18	18	25	30	30	45	80	80
Permissible vacuum	[bar]	-0.2	-0.3	-0.5								-1				
Output signal / Supply																
Standard	2-wire: 4 ... 20 mA / V _S = 14 ... 36 V _{DC}															
Option IS-version	2-wire: 4 ... 20 mA / V _S = 14 ... 28 V _{DC}															
On request	3-wire: 0 ... 10 V / V _S = 14 ... 36 V _{DC}															
Performance																
Accuracy ¹	standard: ≤ ± 0.35 % FSO option: ≤ ± 0.25 % FSO others on request															
Permissible load	current 2-wire: R _{max} = [(V _S - V _{S min}) / 0.02 A] Ω voltage 3-wire: R _{min} = 10 kΩ															
Influence effects	supply: 0.05 % FSO / 10 V load: 0.05 % FSO / kΩ															
Long term stability	≤ ± 0.1 % FSO / year															
Turn-on time	450 msec															
Mean response time	≤ 70 msec															
Measuring rate	80 Hz															
¹ accuracy according to IEC 60770 - limit point adjustment (non-linearity, hysteresis, repeatability)																
Thermal effects (offset and span)																
Tolerance band	≤ ± 1 % FSO															
in compensated range	-20 ... 80 °C															
Permissible temperatures																
Medium ²	-40 ... 125 °C															
Electronics / environment	-40 ... 85 °C															
Storage	-40 ... 85 °C															
² for pressure port in PVDF or PP-HT the operation medium temperature is -30 ... 60 °C																
Electrical protection																
Short-circuit protection	permanent															
Reverse polarity protection	no damage, but also no function															
Electromagnetic compatibility	emission and immunity according to EN 61326															
Mechanical stability																
Vibration	10 g RMS (25 ... 2000 Hz) according to DIN EN 60068-2-6															
Materials																
Pressure port / housing	standard: options for G3/4" flush:	pressure port					housing									
		stainless steel 1.4404 (316 L) PVDF PP-HT					stainless steel 1.4404 (316 L) PVDF PP-HT									
Option compact field housing	stainless steel 1.4301 (304) cable gland M12x1.5, brass, nickel plated (clamping range 2 ... 8 mm)															
Seals (O-rings)	FKM, EPDM, FFKM												others on request			
Diaphragm	ceramics Al ₂ O ₃ 99.9 %												others on request			
Media wetted parts	pressure port, seals, diaphragm															
Explosion protection (only for 4 ... 20 mA / 2-wire)																
Approval DX14B-IMK 387	IBExU 15 ATEX 1066 X / IECEx IBE 18.0019X pressure port: stainless steel zone 0: II 1G Ex ia IIC T4 Ga pressure port: PVDF or PP-HT zone 1: II 2G Ex ia IIC T4 Gb for all pressure ports zone 20: II 1D Ex ia IIIC T135 °C Da															
Safety technical maximum values	U _i = 28 V, I _i = 93 mA, P _i = 660 mW, C _i = 14 nF, L _i = 0 μH, the supply connections have an inner capacity of max. 27 nF to the housing															
Permissible temperatures for environment	in zone 0: -20 ... 60 °C with p _{atm} 0.8 bar up to 1.1 bar in zone 1 or higher: -25 ... 65 °C															
Connecting cables (by factory)	cable capacitance: signal line/shield also signal line/signal line: 160 pF/m cable inductance: signal line/shield also signal line/signal line: 1 μH/m															

Miscellaneous	
Current consumption	max. 22 mA
Weight	approx. 180 g
Operational life	100 million load cycles
CE-conformity	EMC Directive: 2014/30/EU
ATEX Directive	2014/34/EU

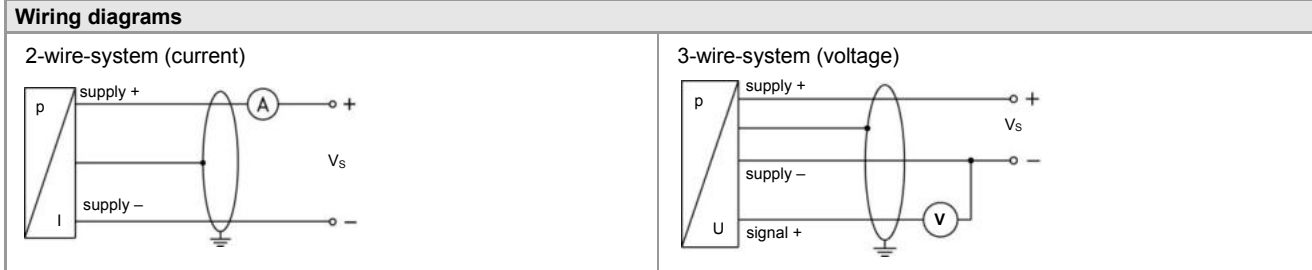

Pin configuration

Electrical connection	ISO 4400	Binder 723 (5-pin)	M12x1 / metal (4-pin)	compact field housing	cable colours (IEC 60757)
supply +	1	3	1	V _{S+}	WH (white)
supply -	2	4	2	V _{S-}	BN (brown)
signal + (only 3-wire)	3	1	3	S+	GN (green)
Shield	ground pin	5	4	GND	GNYE (green-yellow)

Electrical connections (dimensions mm / in)

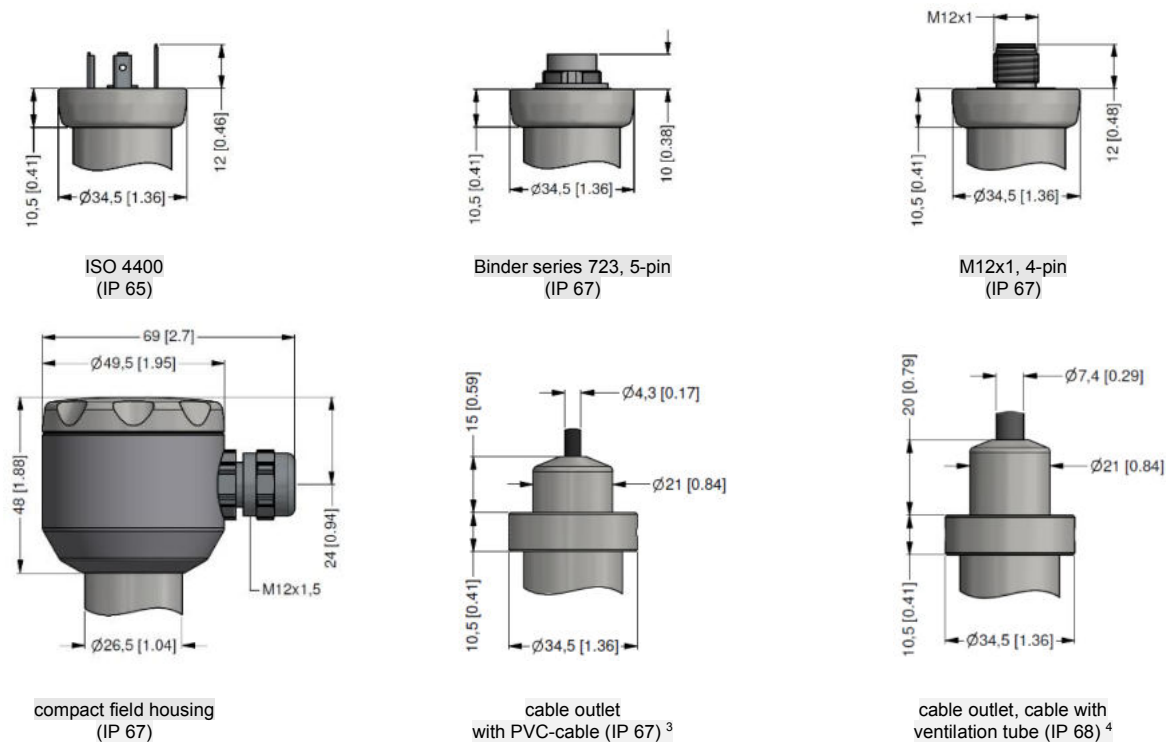

⇒ universal field housing stainless steel 1.4404 (316 L) with cable gland M20x1.5 (ordering code 880) and other versions on request

³ standard: 2 m PVC cable without ventilation tube (permissible temperature: -5 ... 70 °C)
⁴ different cable types and lengths available, permissible temperature depends on kind of cable

Dimensions (mm / in)

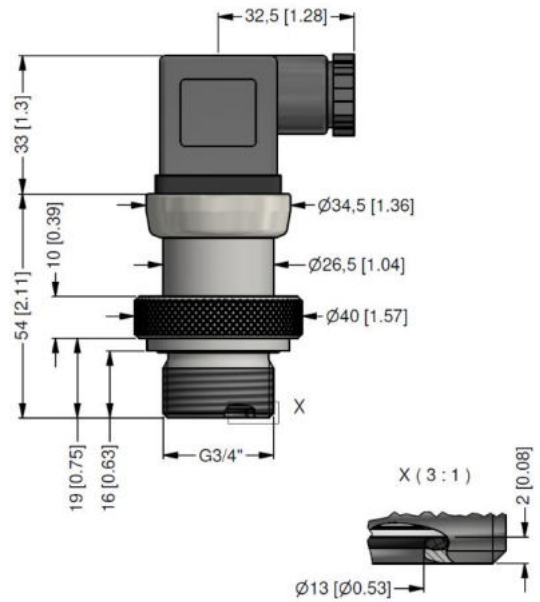
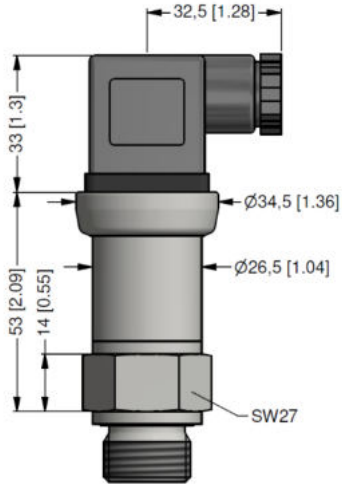

G 3/4" flush⁵

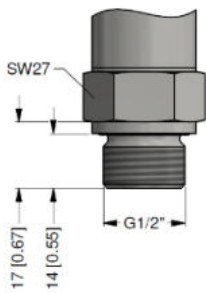

G1/2" DIN 3852

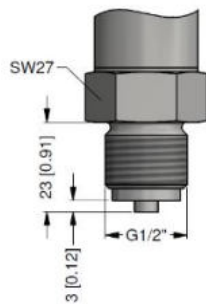

G1/2" EN 837

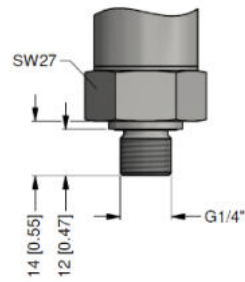

G1/4" DIN 3852

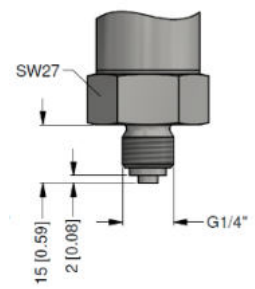

G1/4" EN 837

⁵ not in combination with field housing

Ordering code IMK 387

IMK 387



Pressure											
	gauge in bar	2	8	5							
	gauge in mH ₂ O	2	8	6							
Input											
	[mH ₂ O]	[bar]									
	1.0	0.1	1	0	0	0					
	1.6	0.16	1	6	0	0					
	2.5	0.25	2	5	0	0					
	4.0	0.40	4	0	0	0					
	6.0	0.60	6	0	0	0					
	10	1.0	1	0	0	1					
	16	1.6	1	6	0	1					
	25	2.5	2	5	0	1					
	40	4.0	4	0	0	1					
	60	6.0	6	0	0	1					
	100	10	1	0	0	2					
	160	16	1	6	0	2					
	250	25	2	5	0	2					
	400	40	4	0	0	2					
	600	60	6	0	0	2					
	customer		9	9	9	9					consult
Output											
	4 ... 20 mA / 2-wire					1					
	0 ... 10 V / 3-wire					3					consult
	intrinsic safety 4 ... 20 mA / 2-wire					E					consult
	customer					9					consult
Accuracy											
	standard	0.35 % FSO				3					
	option	0.25 % FSO				2					
	customer					9					consult
Electrical connection											
	male and female plug ISO 4400					1	0	0			
	male plug Binder series 723 (5-pin)					2	0	0			
	cable outlet with PVC cable (IP67) ¹					T	A	0			
	cable outlet,										
	cable with ventilation tube (IP68) ²					T	R	0			
	male plug M12x1 (4-pin) / metal					M	1	0			
	compact field housing					8	5	0			
	stainless steel 1.4301 (304)										
	customer					9	9	9			consult
Mechanical connection ³											
	G1/2" DIN 3852					1	0	0			
	G1/2" EN 837					2	0	0			
	G1/4" DIN 3852					3	0	0			
	G1/4" EN 837					4	0	0			
	G3/4" with flush sensor ⁴					K	0	0			
	customer					9	9	9			consult
Seal											
	FKM					1					
	EPDM					3					
	FFKM					7					
	customer					9					consult
Pressure port											
	stainless steel 1.4404 (316L)								1		
	PVDF ⁵								B		
	PP-HT ⁵								R		
	customer								9		consult
Diaphragm											
	ceramics Al ₂ O ₃ 99,9 %								C		
	customer								9		consult
Special version											
	standard								0	0	0
	customer								9	9	9
											consult

¹ standard: 2 m PVC cable without ventilation tube (permissible temperature: -5 ... 70 °C); others on request

² code TR0 = PVC cable, cable with ventilation tube available in different types and lengths

³ metric threads and others on request

⁴ not in combination with field housing

⁵ only for mechanical connection G3/4"; for pressure port in PVDF or PP-HT the operation medium temperature is -30 ... 60 °C