



# ILMP 331

## Screw-In Transmitter

Stainless Steel Sensor

accuracy according to IEC 60770:  
standard: 0.35 % FSO  
option: 0.25 % / 0.1 % FSO

### Nominal pressure

from 0 ... 100 mbar up to 0 ... 40 bar

### Output signals

2-wire: 4 ... 20 mA

3-wire: 0 ... 20 mA / 0 ... 10 V

others on request

### Special characteristics

- ▶ pressure port G 3/4" flush
- ▶ excellent accuracy
- ▶ small thermal effect
- ▶ excellent long term stability



### Optional versions

- ▶ accuracy 0.1% FSO IEC 60770
- ▶ IS-version:  
Ex ia = intrinsically safe  
for gases and dusts
- ▶ SIL 2 application according to  
IEC 61508 / IEC 61511
- ▶ different electrical connections
- ▶ customer specific versions  
e. g. special pressure ranges

The screw-in transmitter ILMP 331 has been designed for continuous level measurement and is characterized by an excellent performance and a robust construction. The modular construction allows the user the highest possible flexibility in the adaption of ILMP 331.

Optional features like e.g. an intrinsically safe version or a functionally safe version (SIL 2) increase the advantages when launching and realizing projects for plants and systems.

### Preferred areas of use are

-  Plant and machine engineering
-  Energy industry
-  Environmental engineering  
(water – sewage – recycling)



Input pressure range																			
Nominal pressure gauge	[bar]	0.10	0.16	0.25	0.40	0.60	1	1.6	2.5	4	6	10	16	25	40				
Level	[mH <sub>2</sub> O]	1	1.6	2.5	4	6	10	16	25	40	60	100	160	250	400				
Overpressure	[bar]	0.5	1	1	2	5	5	10	10	20	40	40	80	80	105				
Burst pressure ≥	[bar]	1.5	1.5	1.5	3	7.5	7.5	15	15	25	50	50	120	120	210				
Vacuum resistance		p <sub>N</sub> ≥ 1 bar: unlimited vacuum resistance									p <sub>N</sub> < 1 bar: on request								
Output signal / Supply																			
Standard		2-wire: 4 ... 20 mA / V <sub>S</sub> = 8 ... 32 V <sub>DC</sub>									SIL-version: V <sub>S</sub> = 14 ... 28 V <sub>DC</sub>								
Option IS-version		2-wire: 4 ... 20 mA / V <sub>S</sub> = 10 ... 28 V <sub>DC</sub>									SIL-version: V <sub>S</sub> = 14 ... 28 V <sub>DC</sub>								
Options 3-wire		3-wire: 0 ... 20 mA / V <sub>S</sub> = 14 ... 30 V <sub>DC</sub>									0 ... 10 V / V <sub>S</sub> = 14 ... 30 V <sub>DC</sub>								
Performance																			
Accuracy 1		standard: nominal pressure < 0.4 bar:			≤ ± 0.5 % FSO			nominal pressure ≥ 0.4 bar:			≤ ± 0.35 % FSO								
		option 1: nominal pressure ≥ 0.4 bar:			≤ ± 0.25 % FSO			option 2: for all nominal pressures:			≤ ± 0.1 % FSO								
Permissible load		current 2-wire:			R <sub>max</sub> = [(V <sub>S</sub> - V <sub>S min</sub> ) / 0.02 A] Ω			current 3-wire:			R <sub>max</sub> = 240 Ω			voltage 3-wire:			R <sub>min</sub> = 10 kΩ		
Influence effects		supply: 0.05 % FSO / 10 V									load: 0.05 % FSO / kΩ								
Long term stability		≤ ± 0.1 % FSO / year at reference conditions																	
Response time <sup>2</sup>		2-wire: ≤ 10 msec									3-wire: ≤ 3 msec								
<sup>1</sup> accuracy according to IEC 60770 – limit point adjustment (non-linearity, hysteresis, repeatability)																			
<sup>2</sup> with optional accuracy 0.1 % FSO the response time is 200 msec																			
Thermal effects (offset and span)																			
Nominal pressure p <sub>N</sub>	[bar]	≤ 0.40						> 0.40											
Tolerance band	[% FSO]	≤ ± 1						≤ ± 0.75											
in compensated range	[°C]	0 ... 70						-20 ... 85											
Permissible temperatures																			
Permissible temperatures		medium: -40 ... 125 °C				electronics / environment: -40 ... 85 °C				storage: -40 ... 100 °C									
Electrical protection																			
Short-circuit protection		permanent																	
Reverse polarity protection		no damage, but also no function																	
Electromagnetic compatibility		emission and immunity according to EN 61326																	
Mechanical stability																			
Vibration		20 g RMS / 10 ... 2000 Hz									according to DIN EN 60068-2-6								
Shock		500 g / 1 msec half sine									according to DIN EN 60068-2-27								
Explosion protection (only for 4 ... 20 mA / 2-wire)																			
Approvals		IBExU 10 ATEX 1068 X / IECEx IBE 12.0027X																	
DX19-ILMP 331		zone 0: II 1G Ex ia IIC T4 Ga																	
		zone 20: II 1D Ex ia IIIC T135 °C Da																	
Safety technical maximum values		U <sub>i</sub> = 28 V, I <sub>i</sub> = 93 mA, P <sub>i</sub> = 660 mW, C <sub>i</sub> ≈ 0nF, L <sub>i</sub> ≈ 0 μH, the supply connections have an inner capacity of max. 27 nF opposite the housing																	
Permissible temperature for medium		in zone 0: -20 ... 60 °C with p <sub>atm</sub> 0.8 bar up to 1.1 bar																	
		in zone 1 or higher: -40/-20 ... 70 °C																	
Connecting cables (by factory)		cable capacitance: signal line/shield also signal line / signal line: 160 pF/m																	
		cable inductance: signal line /shield also signal line / signal line: 1 μH/m																	
Materials																			
Pressure port		stainless steel 1.4404 (316L)																	
Housing		stainless steel 1.4404 (316L)																	
Option compact field housing		stainless steel 1.4301 (304); cable gland M12x1.5, brass, nickel plated (clamping range 2 ... 8 mm)																	
Seals		standard: FKM																	
		option: EPDM																	
		others on request																	
Diaphragm		stainless steel 1.4435 (316L)																	
Media wetted parts		pressure port, seals, diaphragm																	
Miscellaneous																			
Optionally SIL 2 version <sup>3</sup>		according to IEC 61508 / IEC 61511																	
Current consumption		signal output current: max. 25 mA									signal output voltage: max. 7 mA								
Weight		approx. 200 g																	
Installation position		any <sup>4</sup>																	
Operational life		100 million load cycles																	
CE-conformity		EMC Directive: 2014/30/EU																	
ATEX Directive		2014/34/EU																	
<sup>3</sup> only for 4...20mA / 2-wire; not in combination with the accuracy 0.1%																			
<sup>4</sup> Pressure transmitters are calibrated in a vertical position with the pressure connection down. If this position is changed on installation there can be slight deviation in the zero point for pressure ranges p <sub>N</sub> ≤ 1 bar.																			

# ILMP 331

Stainless Steel Screw-In Transmitter

Technical Data

Pin configuration					
Electrical connections	ISO 4400	Binder 723 (5-pin)	M12x1 / metal (4-pin)	compact field housing	cable colours (IEC 60757)
Supply +	1	3	1	IN +	WH (white)
Supply -	2	4	2	IN -	BN (brown)
Signal + (only for 3-wire)	3	1	3	OUT +	GN (green)
Shield	ground pin $\oplus$	5	4	$\oplus$	GNYE (green-yellow)

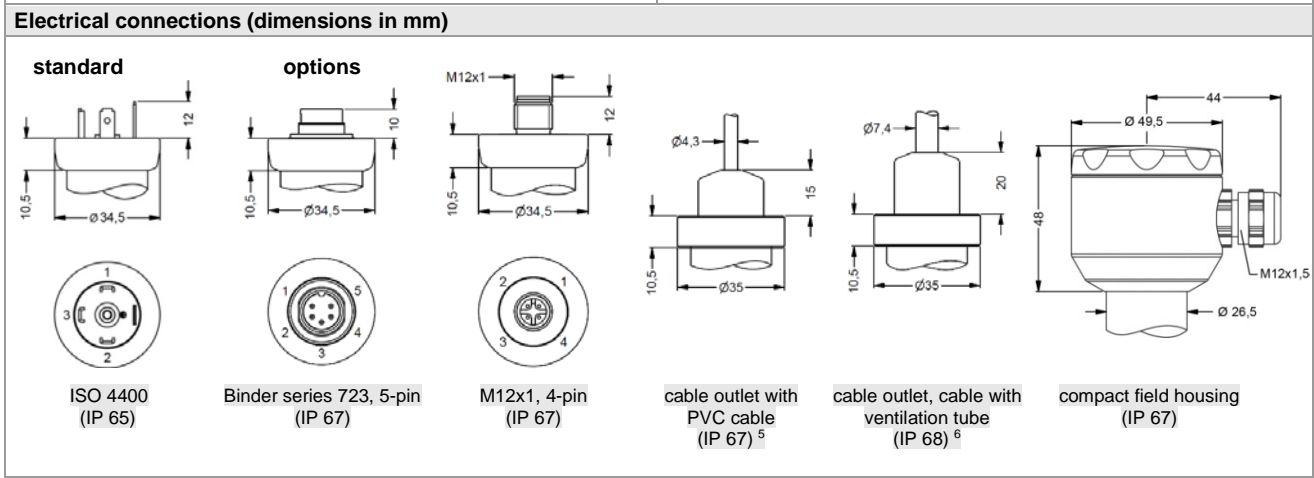
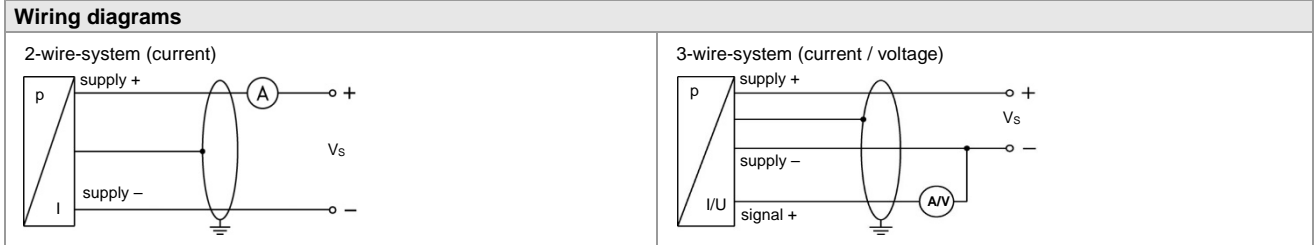

<sup>5</sup> standard: 2 m PVC cable (without ventilation tube, permissible temperature: -5 ... 70 °C)

<sup>6</sup> different cable types and lengths available, permissible temperature depends on kind of cable

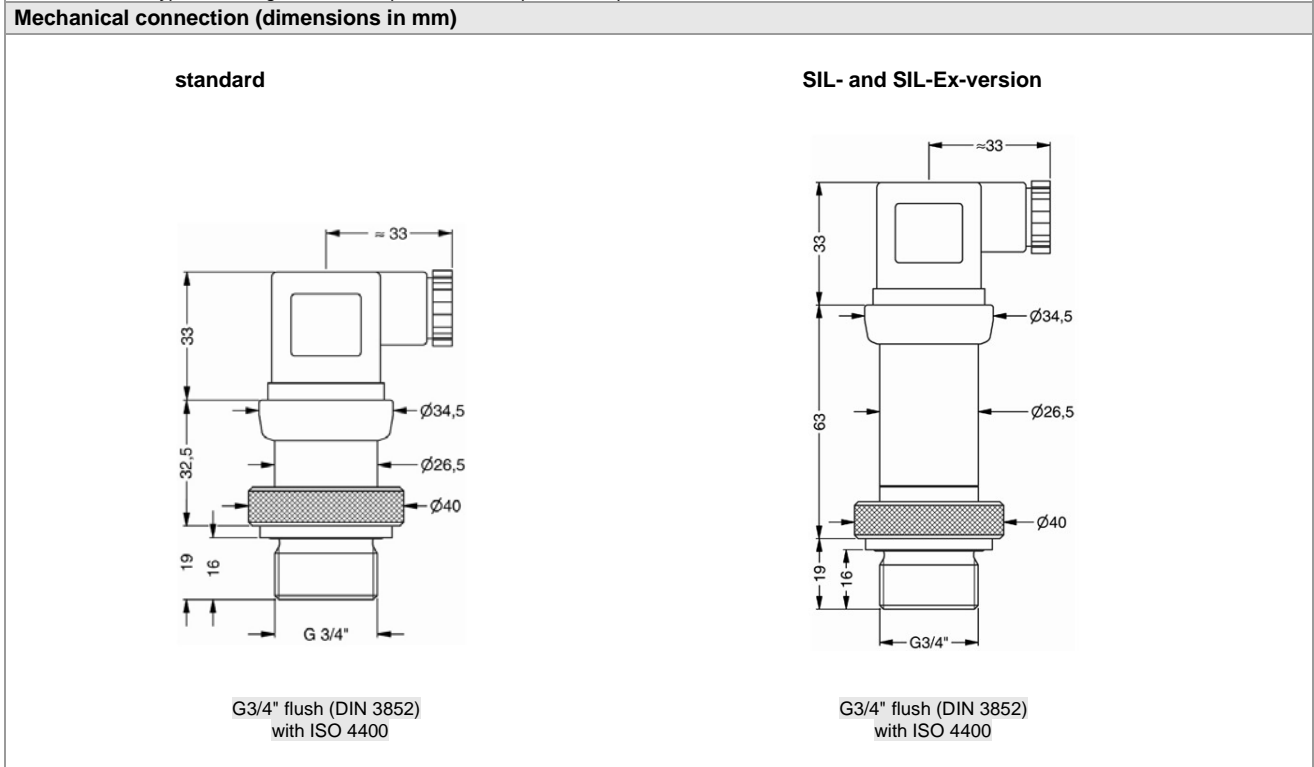

## Ordering code ILMP 331

ILMP 331

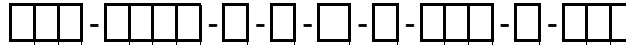

Pressure																			
	in bar	4	3	0															
	in mH <sub>2</sub> O	4	3	1															
Input		[mH <sub>2</sub> O]	[bar]																
	1.0	0.10		1	0	0	0												
	1.6	0.16		1	6	0	0												
	2.5	0.25		2	5	0	0												
	4.0	0.40		4	0	0	0												
	6.0	0.60		6	0	0	0												
	10	1.0		1	0	0	1												
	16	1.6		1	6	0	1												
	25	2.5		2	5	0	1												
	40	4.0		4	0	0	1												
	60	6.0		6	0	0	1												
	100	10		1	0	0	2												
	160	16		1	6	0	2												
	250	25		2	5	0	2												
	400	40		4	0	0	2												
	customer			9	9	9	9											consult	
Pressure port																			
	stainless steel 1.4404 (316L)							1											
	customer							9										consult	
Diaphragm																			
	stainless steel 1.4435 (316L)																	1	
	customer																	9	
																		consult	
Output																			
	4 ... 20 mA / 2-wire																	1	
	0 ... 20 mA / 3-wire																	2	
	0 ... 10 V / 3-wire																	3	
	intrinsic safety 4 ... 20 mA / 2-wire																	E	
	SIL2 4 ... 20 mA / 2-wire																	1S	
	SIL2 with intrinsic safety 4 ... 20 mA / 2-wire																	ES	
	customer																	9	
																		consult	
Seal																			
	FKM																	1	
	EPDM																	3	
	customer																	9	
																		consult	
Electrical connection																			
	male and female plug ISO 4400																	1 0 0	
	male plug Binder series 723 (5-pin)																	2 0 0	
	cable outlet with PVC cable (IP67) <sup>1</sup>																	T A 0	
	cable outlet, cable with ventilation tube (IP68) <sup>2</sup>																	T R 0	
	male plug M12x1 (4-pin) / metal compact field housing																	M 1 0	
	stainless steel 1.4301 (304)																	8 5 0	
	customer																	9 9 9	
																		consult	
Accuracy																			
	standard for p <sub>N</sub> ≥ 0.4 bar:	0.35 % FSO																3	
	standard for p <sub>N</sub> < 0.4 bar:	0.50 % FSO																5	
	option 1 for p <sub>N</sub> ≥ 0.4 bar:	0.25 % FSO																2	
	option 2:	0.10 % FSO <sup>3</sup>																1	
	customer																	9	
																		consult	
Special version																			
	standard																	0 0 0	
	customer																	9 9 9	
																		consult	

<sup>1</sup> standard: 2 m PVC cable without ventilation tube (permissible temperature: -5 ... 70 °C), others on request

<sup>2</sup> code TR0 = PVC cable, cable with ventilation tube available in different types and lengths

<sup>3</sup> not in combination with SIL