

5 valve manifold PN 420 DN 5

Type 1 (for remote mounting)

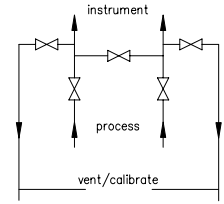
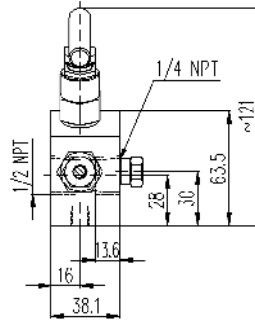
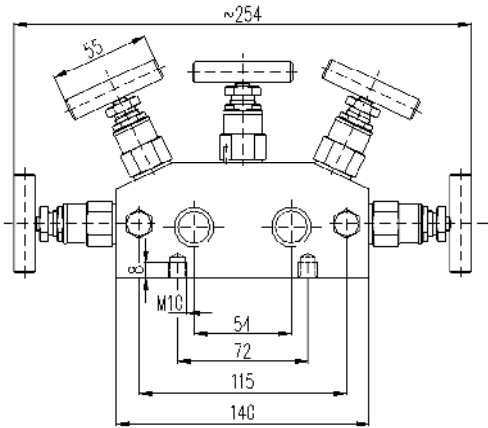

- 1 PTFE packing
- 2 graphite packing - 1.0460
- 3 graphite packing - 1.4404

Type 2 (for direct mounting)

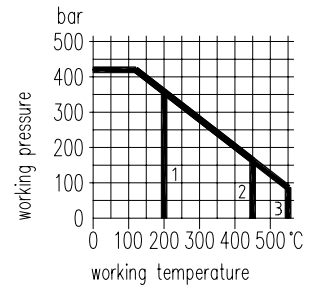
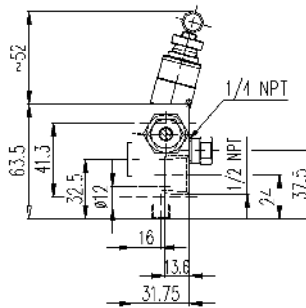
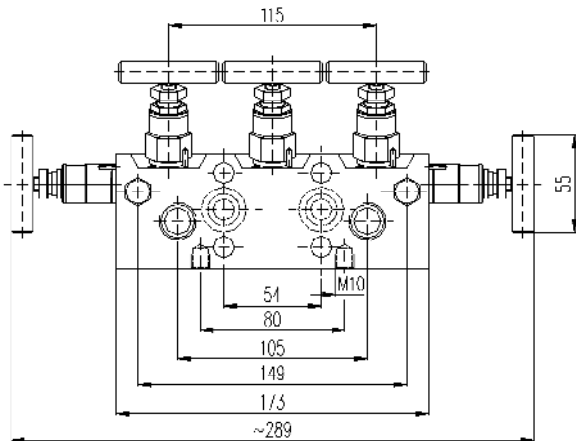

MOUNTING ACCESSORIES see section

Type	Material	Connections		Vent/Calibrate connection	Part no.
		Inlet	Outlet		
1	steel st. stl.	1/2 NPT female		1/4 NPT female, with screw plug	50-V02-5-SC-50-PN420 50-V02-5-SS-50-PN420
2	steel st. stl.	1/2 NPT female	IEC Type A ⁴⁾		50-V02-5A-SC-DN5-PN420 50-V02-5A-SS-DN5-PN420

Components	Steel	Stainless steel ¹⁾
	DIN-Material Number	
Body ²⁾	1.0460	316L (1.4404)
Bonnet	316 (1.4401)	
Valve stem	316L (1.4404)	
Needle tip ³⁾	1.4122 ⁵⁾	316Ti (1.4571)
Packing	PTFE up to 200 °C (graphite up to 550 °C)	
Gland nut	1.0501	304 (1.4301)
T-handle	stainless steel	
Screw plug	1.0501	316L (1.4404)

- Surface: steel phosphatized
- External stem thread
- Stem with cold rolled surface, back seat and non-rotating needle tip
- Special types are available
- The manifolds can be supplied according to NACE-standard

¹⁾ Can also be supplied for oxygen service.

Please notice order instruction B 3!

²⁾ Available with inspection certificate 3.1.B acc. to EN 10 204

³⁾ Also available with soft tip in KEL-F[®] (PTFE) or Delrin[®] (POM)

⁴⁾ Dimensions according to IEC document 65 B, Type A see order instruction B 4

⁵⁾ 1.4122 quenched and tempered