

Thermocouple, straight version For industrial furnaces Model TC80, design TC80-H

WIKA data sheet SP 05.24



for further approvals
see page 8

Applications

- General heat treatment processes
- Tempering furnaces
- Primary and secondary metallurgical engineering

Special features

- Application ranges up to max. 1,700 °C [3,100 °F]
per IEC 60584-1 / ASTM E230
- Thermowell from ceramic, also with ceramic inner tube
- Support tube from different steels
- Gas-tight process connection

Description

Model TC80 thermocouples were developed to measure extremely high temperatures. The thermowires of the thermocouple which is built into the thermowell, are fed into either capillary bores in ceramic insulation tubes or into capillary bores in insulation rods. A thermowell from high-temperature ceramic, with or without additional inner tube, protects the thermocouple from the process medium as well as from mechanical and chemical damage.

An optional stop flange allows direct mounting into the process. Optionally, a transmitter can be built in. Among the advantages of a built-in transmitter is an increased reliability of the signal transmission. Lower-cost copper cable can then be used, in place of specific thermocouple and compensating cables, between the transmitter and the control room. A cold junction is integrated into all WIKA transmitters.



Thermocouple, model TC80

Model overview and dimensions in mm

AK version

- Connection head form A
- Ceramic thermowell
- Metal support tube

A	Nominal length	500 / 710 / 1,000 / 1,400 / 2,000 ¹⁾
ØF	Thermowell outer Ø	24
N	Support tube length	200 (standard)
ØF ₄	Support tube Ø	32

1) This nominal length is not suitable for vertical installation with a built-in precious-metal thermocouple.

AKK version

- Connection head form A
- Ceramic thermowell
- Metal support tube
- Ceramic inner tube

A	Nominal length	500 / 710 / 1,000 / 1,400
ØF	Thermowell outer Ø	24
N	Support tube length	200 (standard)
ØF ₄	Support tube Ø	32

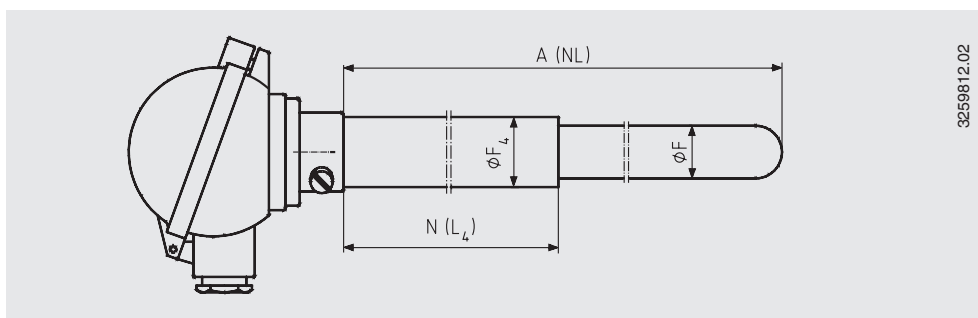

3259812.02

Sensor

Sensor types

Type	Operating temperatures per			
	IEC 60584-1		ASTM E230	
	Class 1	Class 2	Standard	Special
K	-40 ... +1,000 °C	-40 ... +1,200 °C	0 ... 1,260 °C	
N	-40 ... +1,000 °C	-40 ... +1,200 °C	0 ... 1,260 °C	
R	0 ... 1,600 °C		0 ... 1,480 °C	
S	0 ... 1,600 °C		0 ... 1,480 °C	
B	-	600 ... 1,700 °C	870 ... 1,700 °C	-

The actual operating temperature of the thermometer is limited both by the maximum permissible working temperature of the thermocouple, as well as by the maximum permissible working temperature of the thermowell material.

The long-term stability of precious-metal thermocouples rises with increasing thermowire diameter. The type S, R and B sensors are available with thermowire diameters of Ø 0.35 mm or Ø 0.5 mm.

For detailed specifications for thermocouples, see IEC 60584-1 or ASTM E230 and Technical information IN 00.23 at www.wika.com.

Number of measuring points

Listed models are available both as single or dual thermocouples. The thermocouple will be delivered with an ungrounded measuring point.

Electrical connection

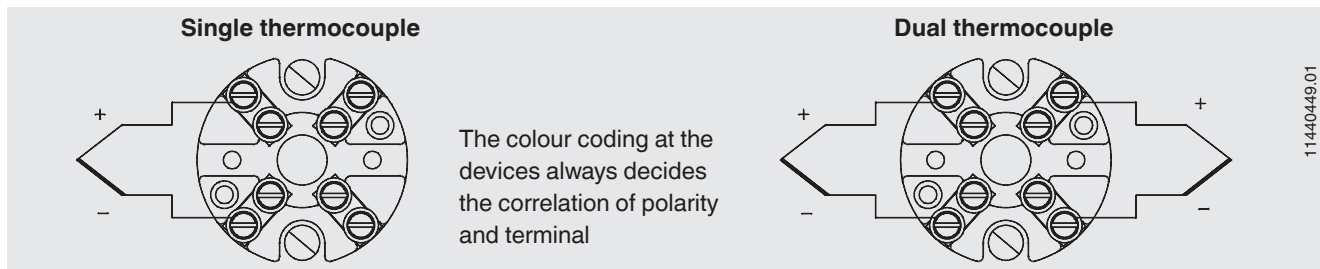

For the electrical connections of built-in temperature transmitters see the corresponding data sheets or operating instructions.

Colour coding at the terminal block

Sensor	IEC 60584-1		ASTM E230	
	Positive	Negative	Positive	Negative
K	Green	White	Yellow	Red
N	Pink	White	Orange	Red
S	Orange	White	Black	Red
R	Orange	White	Black	Red
B	Grey	White	Grey	Red

Versions

Depending on the ceramic used, the upper operating temperature limit of ceramic thermowells can be up to 1,700 °C, with higher temperatures on request. Generally a precious-metal thermocouple is used as a sensor (types R, S and B).

For the measurement of temperatures above 1,200 °C, only precious-metal thermocouples can be used as sensor. With precious-metal thermocouples, however, there is a risk of 'poisoning' by contamination. This risk rises with increasing temperatures. Therefore, at temperatures above 1,200 °C, gas-tight ceramics should be used, preferably high-purity C 799 (see "Remarks on the selection and operation of thermowells").

The process connection is designed to be gas-tight up to 1 bar. With toxic or safety-critical process gases or special installation situations, it is recommended to take further constructive measures in addition to the standard features, in order to avoid any leakage of the medium to the outside via the connection head, in the event of a thermowell fracture (e.g. pressure-sealed feed-through in the connection head).

Design of thermocouple

Base-metal thermocouple types K, N

Thermowire: \varnothing 1 mm or \varnothing 3 mm
 Insulation: Insulation tube, ceramic

3168469.01

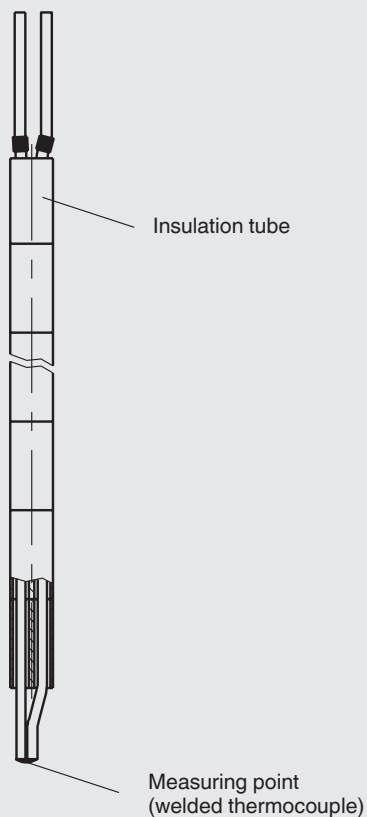

Precious-metal thermocouple types S, R, B

Thermowire: \varnothing 0.35 mm or \varnothing 0.5 mm
 Insulation: Insulation rod, ceramic

3168477.01

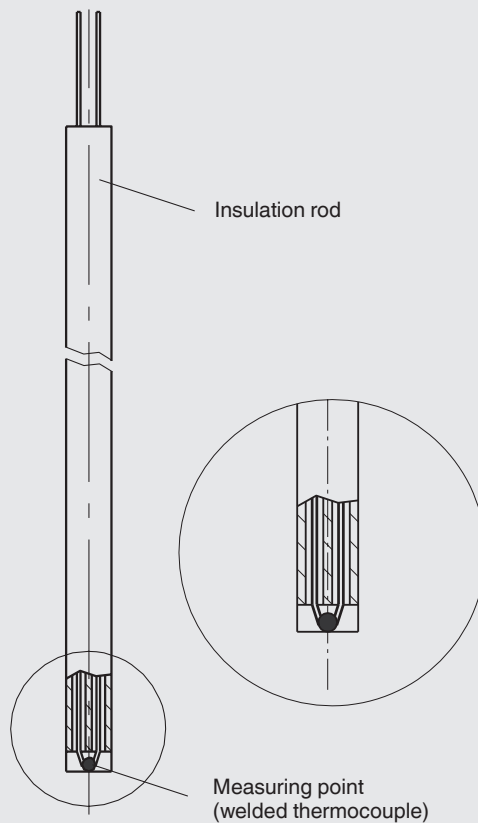

Connection head

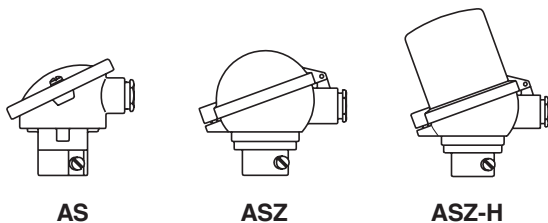

Model	Material	Cable entry thread size	Ingress protection	Cap	Surface
AS	Aluminium	M20 x 1.5 ¹⁾	IP53	Cap with 2 screws	Blue, painted ²⁾
ASZ	Aluminium	M20 x 1.5 ¹⁾	IP53	Hinged cover with cylinder head screw	Blue, painted ²⁾
ASZ-H	Aluminium	M20 x 1.5 ¹⁾	IP53	Hinged cover with cylinder head screw	Blue, painted ²⁾

1) Standard
 2) RAL 5022

Transmitter (option)

The transmitter can be mounted directly into the thermometer. Attention must be paid to the permissible ambient temperature of the transmitter in accordance with the data sheet. With a direct connection of the thermocouple to the transmitter – due to the heat transfer of the thermowires – the risk of an unacceptably high heating of the transmitter terminals increases. The thermocouple can also be indirectly connected to the transmitter using a short piece of thin compensating cable between terminal block and transmitter.

Hence, the resulting mounting in the cap of the connection head requires a connection head with a high model ASZ-H cap.

Connection head	Transmitter model		
	T16	T32	T53
AS	-	-	-
ASZ	-	-	-
ASZ-H	●	●	●

- Mounted within the cover of the connection head
- Mounting not possible

Model	Description	Data sheet
T16	Digital transmitter, PC configurable	TE 16.01
T32	Digital transmitter, HART® protocol	TE 32.04
T53	Digital transmitter FOUNDATION™ Fieldbus and PROFIBUS® PA	TE 53.01

Support tube

Material: DIN 1.0305, DIN 1.4841, AISI 446, AISI 310
 Outer diameter $\varnothing F_4 = 32$ mm
 Length $N (L_4) = 200, 150$ or 100 mm

Ceramic thermowell

Ceramic thermowells are made from high-fired aluminium oxide ceramics, the tip is closed and hemispherical. Due to the low mechanical strength, a metal support tube is used to fix the process connection to the thermocouple. The ceramic thermowell is cemented into the support tube using a fireproof ceramic compound. The support tube is inserted into the connection head and clamped.

Nominal lengths

$A = 500 / 710 / 1,000 / 1,400 / 2,000$ mm

Materials for ceramic thermowells 1)

- Ceramic C 610 gas-tight
 usable up to $1,500$ °C, not resistant to alkali vapours
- Ceramic C 799 gas-tight, high-purity
 usable up to $1,600$ °C, however, only partially resistant to changes in temperature, not resistant to alkali vapours

1) see "Remarks on the selection and operation of thermowells"

Thermowell design

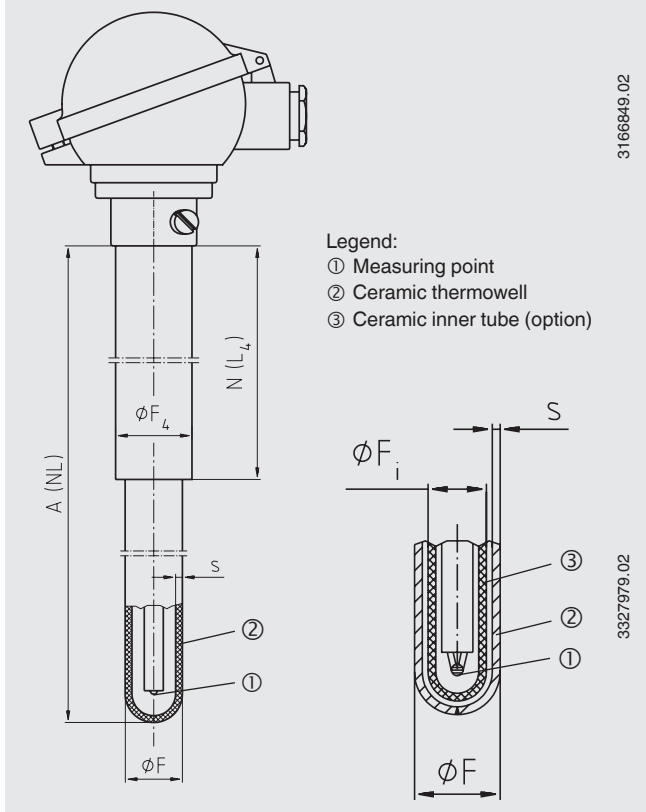

3166849.02

3327979.02

Mounting instructions for ceramic thermowells

The C 799 ceramic material is only partially resistant to changes in temperature. A temperature shock can therefore easily result in stress cracks and consequently in damage to the ceramic thermowell. For this reason, thermocouples with thermowells of C 799 ceramic must be pre-heated before installation, and then slowly inserted into the hot process.

Depending on the ambient and process temperatures present, this procedure is also recommended for the other ceramic materials.

In addition to the protection from thermal stress, ceramic thermowells must also be protected from mechanical loads. Such damaging stress conditions are caused by bending forces acting in a horizontal mounting position. Thus, with horizontal installation (and dependent upon diameter, nominal length and design), additional support should be provided by the customer.

Process connection

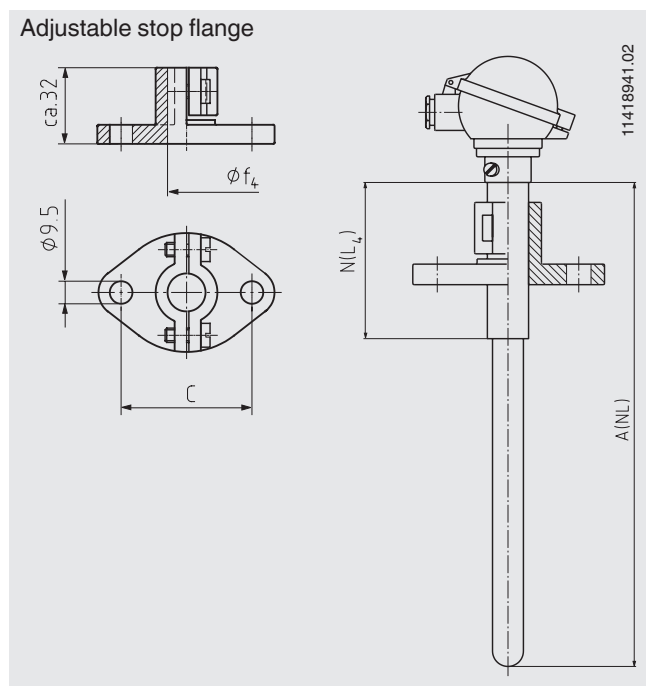

The optional stop flange is adjustable on the support tube and is secured using a clamp.

Therefore, the insertion length within the limit of the support tube length is variable and can be easily adjusted at the mounting point.

Dimensions in mm for thermowell and inner tube

Ceramic thermowell		Ceramic inner tube
External Ø	Wall thickness	External Ø
Ø F	s	Ø F _i
22, 26	2 - 4	15, 16
15, 16	2	10

Material: Carbon steel or malleable cast iron
others on request

Thermowell outer diameter: 32 mm
Inner diameter Ø f₄: 32.5 mm
Hole centre spacing C: 70 mm

Remarks on the selection and operation of thermowells

Ceramic thermowells should be considered to be gas-tight in accordance with the DIN EN 50446 standard. A diffusion of gas from the process into the sensor cannot be ruled out, particularly at high temperatures.

As a result of this, the resistance of the thermocouple material to the medium should be explicitly considered. The responsibility for the choice of materials for the safe function of the thermometer/thermowell within the plant/machinery is the responsibility of the customer/operator. WIKA can only give recommendations which are based on our experience in similar applications.

The following table does not claim to be complete. All information is non-binding and does not represent guaranteed characteristics. They should be fully tested by the customer using the conditions of the respective application.

Resistance when in contact with gases

Material	Applicable in air up to	Resistance against			
		Sulphurous gases		Nitrogenous, low-oxygen gases	Carburisation
		Oxidising	Reducing		
DIN 1.0305	550 °C	low	slight	medium	slight
DIN 1.4841	1,150 °C	very slight	very slight	high	slight
AISI 446	1,150 °C	very high	high	slight	medium
AISI 310	1,150 °C	very slight	very slight	high	slight

Accessories

Model	Special features	Order number
Threaded bushing	Material: stainless steel 1.0718 Process connection: G 1 1/4 Support tube outer diameter Ø F ₄ = 32 mm Adjustable, gas-tight up to 1 bar Sealing: asbestos-free, up to max. 200 °C	14190141
	Material: stainless steel 1.4571 Process connection: G 1 1/4 Support tube outer diameter Ø F ₄ = 32 mm Adjustable, gas-tight up to 1 bar Sealing: asbestos-free, up to max. 200 °C	14190140

Approvals

Logo	Description	Country
	EU declaration of conformity EMC directive ¹⁾	European Community
	EAC (option) Electromagnetic compatibility ¹⁾	Eurasian Economic Community
	GOST (option) Metrology, measurement technology	Russia
	KazInMetr (option) Metrology, measurement technology	Kazakhstan
-	MTSCHS (option) Permission for commissioning	Kazakhstan
	BelGIM (option) Metrology, measurement technology	Belarus
	Uzstandard (option) Metrology, measurement technology	Uzbekistan

1) Only for built-in transmitter

Certificates (option)

Certification type	Measurement accuracy	Material certificate
2.2 test report	x	x

The different certifications can be combined with each other.

Approvals and certificates, see website