



IDCT 531

Industrial Pressure Transmitter with RS485 Modbus RTU

Stainless Steel Sensor

accuracy according to IEC 60770:
0.25 % FSO

Nominal pressure

from 0 ... 100 mbar up to 0 ... 400 b

output signal

RS485 with Modbus RTU protocol

Special characteristic

- ▶ pressure value
- ▶ perfect thermal behaviour
- ▶ excellent long term stability
- ▶ reset function

Optional versions

- ▶ pressure port
G 1/2" flush up to max. 40 bar
- ▶ pressure sensor welded
- ▶ customer specific versions

The IDCT 531 with RS485 interface uses the communication protocol Modbus RTU which has found the way in industrial communication as an open protocol. The Modbus protocol is based on a master slave architecture with which up to 247 slaves can be questioned by a master.

Due to the usage of high quality materials and components, the IDCT 531 is suitable for almost every industrial application, if the medium is compatible with stainless steel 316L.

The modular concept of the device allows customized mechanical connections, so it is easy to adapt the pressure transmitter to different conditions on-site.

Preferred areas of use are



Plant and machine engineering



Energy industry



Modbus®

Input pressure range												
Nominal pressure gauge	[bar]	-1...0	0.10	0.16	0.25	0.40	0.60	1	1.6	2.5	4	6
Nominal pressure absolute	[bar]	-	-	-	-	0.40	0.60	1	1.6	2.5	4	6
Overpressure	[bar]	5	0.5	1	1	2	5	5	10	10	20	40
Burst pressure \geq	[bar]	7.5	1.5	1.5	1.5	3	7.5	7.5	15	15	25	50

Nominal pressure gauge / absolute	[bar]	10	16	25	40	60	100	160	250	400	
Overpressure	[bar]	40	80	80	105	210	600	600	1000	1000	
Burst pressure \geq	[bar]	50	120	120	210	420	1000	1000	1250	1250	
Vacuum resistance		$p_N \geq 1$ bar: unlimited vacuum resistance					$p_N < 1$ bar: on request				

Output signal	
Digital	RS 485 with Modbus RTU protocol (pressure)

Supply	
Direct current	$V_S = 9 \dots 32 V_{DC}$

Performance	
Accuracy ¹	$\leq \pm 0.25$ % FSO
Long term stability	$\leq \pm 0.1$ % FSO / year at reference conditions
Measuring rate	500 Hz
Delay time	500 msec

¹ accuracy according to IEC 60770 – limit point adjustment (non-linearity, hysteresis, repeatability)

Thermal effects (offset and span)	
Tolerance band	$\leq \pm 0.75$ % FSO
in compensated range	-20 ... 85 °C

Permissible temperatures	
Medium	-40 ... 125 °C
Electronics / environment	-40 ... 85 °C
Storage	-40 ... 100 °C

Electrical protection	
Short-circuit protection	permanent
Reverse polarity protection	on supply connection no damage, but also no function
Electromagnetic compatibility	emission and immunity according to EN 61326

Mechanical stability	
Vibration	10 g RMS (25 ... 2000 Hz) according to DIN EN 60068-2-6
Shock	100 g / 11 msec according to DIN EN 60068-2-27

Materials	
Pressure port / housing	stainless steel 1.4404 (316 L)
Seals	standard: FKM option: EPDM; welded version ² (for $p_N \leq 40$ bar) others on request
Diaphragm	stainless steel 1.4435 (316 L)
Media wetted parts	pressure port, seal, diaphragm

² welded version only with pressure ports according to EN 837, $p_N \leq 40$ bar

Miscellaneous	
Weight	approx. 210 g
Ingress protection	IP 67
Current consumption	max. 10 mA
Operational life	100 million load cycles
Installation position	any ³
CE-conformity	EMC Directive: 2014/30/EU Pressure Equipment Directive: 2014/68/EU (module A) ⁴

³ Pressure transmitters are calibrated in a vertical position with the pressure connection down. If this position is changed on installation there can be slight deviations in the zero point for pressure ranges $p_N \leq 1$ bar.

⁴ This directive is only valid for devices with maximum permissible overpressure > 200 bar

Wiring diagram	
----------------	--

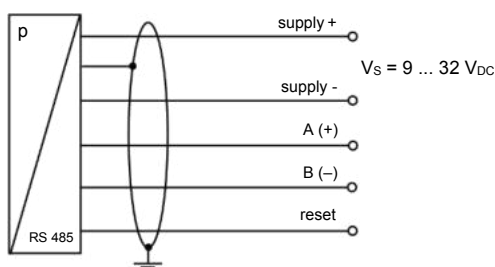

IDCT 531

Industrial Pressure Transmitter with RS485 Modbus RTU

Technical Data

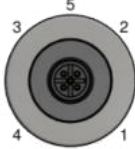
Pin configuration / electrical connection		
Electrical connection	M12x1, metal (5-pin)	
Supply +	1	
Supply -	3	
A (+)	2	
B (-)	4	
Reset	5	
Shield	plug housing	

Dimensions (mm / in)

standard

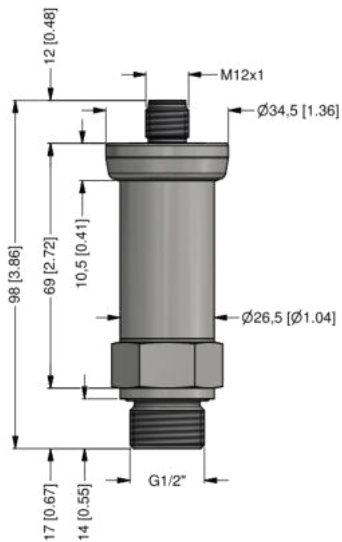

G1/2" DIN 3852 with M12x1

⇒ metric threads and other versions on request

options

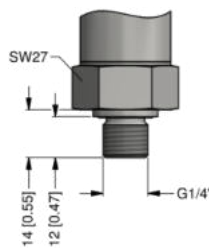

G1/4" DIN 3852

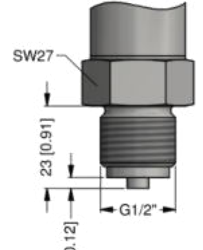

G1/2" EN 837

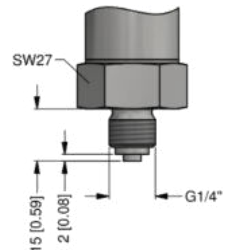

G1/4" EN 837

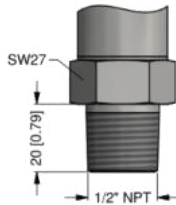

1/2" NPT

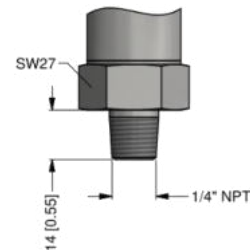

1/4" NPT

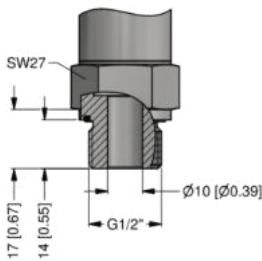

G1/2" DIN 3852 open port ($p_N \leq 40$ bar)

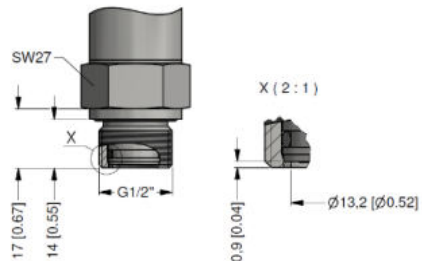

G1/2" DIN 3852 with semi-flush sensor ($p_N \leq 40$ bar)

Configuration Modbus RTU					
Standard configuration	001	-	1	-	1
Address					
Address	001				
	...				
	247				
Baud Rate					
4800 Bd			0		
9600 Bd			1		
19200 Bd			2		
38400 Bd			3		
Parity					
None					0
Odd					1
Even					2

Configuration code (to specify with order)	-	-		
--	---	---	--	--

Ordering code IDCT 531

IDCT 531



Pressure									
	gauge	D	C	7					
	absolute ¹	D	C	8					
Input									
	[bar]								
	0.10	1		1	0	0	0		
	0.16	1		1	6	0	0		
	0.25	1		2	5	0	0		
	0.40			4	0	0	0		
	0.60			6	0	0	0		
	1.0			1	0	0	1		
	1.6			1	6	0	1		
	2.5			2	5	0	1		
	4.0			4	0	0	1		
	6.0			6	0	0	1		
	10			1	0	0	2		
	16			1	6	0	2		
	25			2	5	0	2		
	40			4	0	0	2		
	60			6	0	0	2		
	100			1	0	0	3		
	160			1	6	0	3		
	250			2	5	0	3		
	400			4	0	0	3		
	-1 ... 0			X	1	0	2		
	customer			9	9	9	9		consult
Output									
	RS485 Modbus RTU				L	5			
Accuracy									
	0.25 % FSO						2		
	customer						9		consult
Electrical connection									
	male plug M12x1 (5-pin) / metal						N	1	1
	customer						9	9	9
Mechanical connection									
	G1/2" DIN 3852						1	0	0
	G1/2" EN 837						2	0	0
	G1/4" DIN 3852						3	0	0
	G1/4" EN 837						4	0	0
	G1/2" DIN 3852						F	0	0
	with semi-flush sensor ²								
	G1/2" DIN 3852 open pressure port ²						H	0	0
	1/2" NPT						N	0	0
	1/4" NPT						N	4	0
	customer						9	9	9
Seal									
	FKM							1	
	EPDM							3	
	without (welded version) ³							2	consult
	customer							9	consult
Special version									
	standard							0	0
	customer							9	9

¹ absolute pressure possible from 0.4 bar

² not possible for nominal pressure $p_N > 40$ bar

³ welded version only with pressure ports according to EN 837, possible for $p_N \leq 40$ bar