



Operating Manual

Operating Principle

The Dynisco Echo™ Melt Pressure Sensors are used to make pressure measurements of molten polymers up to 752°F (400°C). These models incorporate a 350-Ohm, bonded foil strain gage Wheatstone Bridge. This proven technology provides an output of 0-3.33 mV/V, & 4-20mA, 05-VDC and 0-10VDC proportional to melt pressure (within the specified error band). Most models include an internal shunt calibration ("Rcal") function that is used to simulate a signal of 80% of full scale. This eliminates the need for a cumbersome calibrated pressure source when scaling associated instrumentation.

Installation

Do not remove protective cap until ready to install.

Prior to initial installation, verify correct machining of mounting hole per Figure 1. Gauge Plug, P/N 200908, is available for this purpose.

Before installing make sure that mounting hole is clear of material. Dynisco Cleaning Tool Kit, P/N 200100, should be used.

To prevent galling, lightly coat transducer threads with a high temperature anti-seize material. An adequate seal, in a properly machined and maintained mounting well, is obtained with 100 in-lbs. mounting torque. The maximum torque recommended is 500 in-lbs.

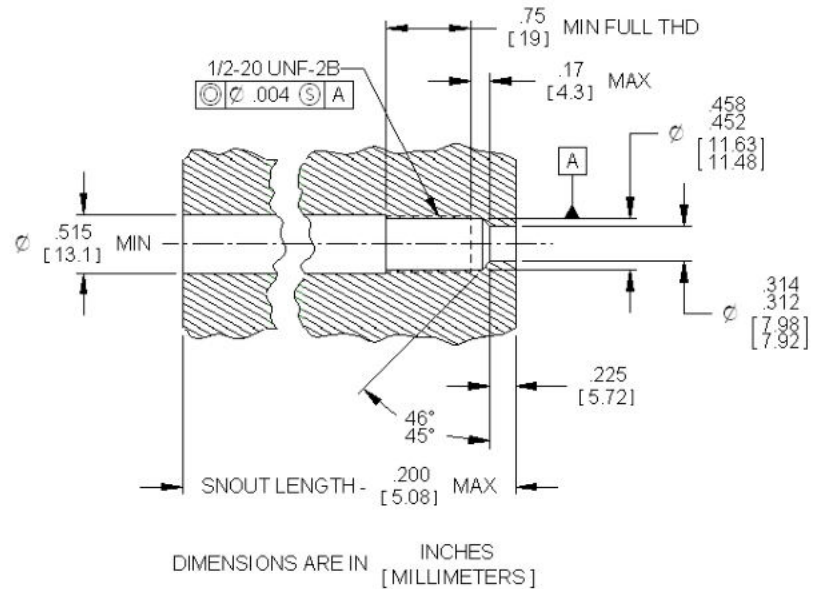

The electronics housing should be secured, with the optional mounting bracket (P/N 200941), in an area where the ambient temperature will not exceed 185°F (85°C). (Mounting bracket not supplied with Echo™ models.)

Wiring

Use shielded cable. Attach cable shield to ground at one end only.

NOTE: DYNISCO cable assemblies are constructed with shield wired to transducer mating connector, so do not attach shield to instrument.

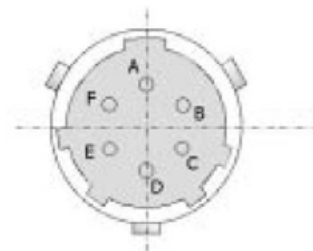

Output	Supply Voltage
mV/V	10 Vdc (12 Vdc max)
mA	14-36 Vdc
Vdc	16-36 Vdc

PIN	VT & MV Wiring	MA Wiring
A	SIG+	SIG+ / EXC+
B	SIG-	SIG- / EXC-
C	EXC+	NO CONNECTION
D	EXC-	
E	INTERNAL R-CAL	INTERNAL R-CAL
F		

Start-Up

Bring system to operating temperature with no pressure. For mA units, remove adjustment access screw and adjust Zero Output potentiometer. For mV/V units, zero adjustment must be handled by downstream indicator. Make sure that there is sufficient "soak time" to assure that any material at the tip of the transducer is molten before extruder drive is started.

Removal

Transducer should only be removed when polymer is hot and liquid. Wipe tip with a soft cloth immediately. The melt pressure transducer must be removed before using an abrasive material or wire brush to clean the extruder barrel. Clean the mounting well before attempting to reinstall the transducer with Dynisco Mounting Well Cleaning Tool Kit, P/N 200100.

Thermocouple

Thermocouples (Type J or K) in a rigid stem are optionally available. The Type J (iron-constantan) and Type K is a T/C junction just behind the flush diaphragm at the tip of the transducer. For the most accurate temperature measurement of the melt stream, use a separate immersion-type thermocouple, such as Dynisco TB422 fixed depth series or (G)RMT adjustable models. The thermocouple assembly can be removed by loosening the set screw on the side of hex assembly and pulling the T/C probe, carefully, straight out, without twisting. Replacement assemblies are available. When installing the thermocouple probe assembly, align the slot with the pressure capillary tube and press into snout until top of probe shoulders flush against snout. Lock in place with set screw.

