



PT375 Flush Diaphragm High Pressure Transducer

Operating Manual



Introduction

The Dynisco model PT375 flush diaphragm pressure transducer is designed to measure from 0 ÷ 1000 psi up to 0 - 30,000 psi. This model incorporates a 350-ohm, bonded foil strain gage Wheatstone Bridge. This proven technology provides an voltage output proportional to pressure (within the specified error band). These transducers convert changes in applied pressure into corresponding changes in voltage signals. These output signals can be fed into a wide range of measurement instrumentation with millivolt capability.

Pressure Fitting

The pressure fitting on the PT375 flush diaphragm pressure transducer is a 3/4"-16 UNF-2A thread. The sealing surfaces the 60° cone near the diaphragm, excluding the threads from the wetted area.

The recommended mounting torque is:

50 ft-lbs.: Ranges ³ 20,000 psi

100 ft-lbs.: Ranges = 30,000 psi

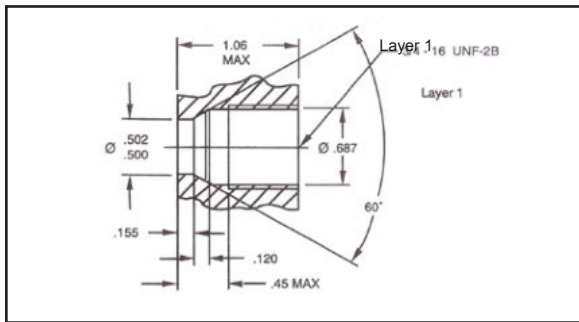

Figure 1: PT375 Mounting Hole Diagram

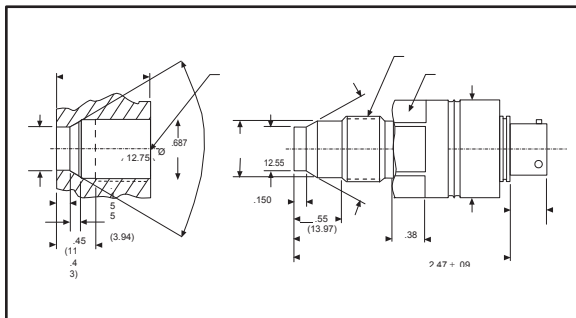

Figure 2: PT375 Schematic

Wiring

All PT375's are equipped with a 6-pin, Bendix PT1H-10-6P (or equal) receptacle. The suggested mating plug is a Bendix PT06W-10-6S or equivalent, Dynisco P/N 711610. The PT375-0 has a six conductor integral cable.

Function	Pin	Color
Signal +	A	Red
Signal -	B	Black
Excitation +	C	White
Excitation -	D	Green
Cal Signal	E, F	Blue, Orange

Figure 3: Wiring Codes for the PT375

Internal Shunt Calibration

Each transducer includes an internal shunt calibration ("R-Cal") function that is used to simulate a signal of 80% full scale, this is achieved by crossing pins E and F. This eliminates the need for cumbersome calibrated pressure source when scaling associated instrumentation.

Transducer Repair

Questions concerning warranty, repair cost, delivery, and requests for a RA# should be directed to the Dynisco Repair Department, 508-541-9400 or email: repair@dynisco.com. Please call for a return authorization number (RA#) before returning any product. Damaged transducers should be returned to:

Dynisco, LLC
Repair Department RA#
38 Forge Parkway, Franklin, MA 02038

Technical Assistance

Please call 800-221-2201 or 508-541-9400 or fax 508-541-9436.

Warranty

This Dynisco product is warranted under terms and conditions set forth in the Dynisco Web Pages. Go to www.dynisco.com and click on "Warranty" at the bottom of any page for complete details.