



IMK 457

Pressure Transmitter for Shipbuilding and Offshore

Ceramic Sensor

accuracy according to IEC 60770:
0.5 % FSO

Nominal pressure

from 0 ... 400 mbar up to 0 ... 600 bar

Output signals

2-wire: 4 ... 20 mA
others on request

Special characteristics

- ▶ LR-certificate (Lloyd's Register)
- ▶ DNV-GL Approval (Det Norske Veritas ▪ Germanischer Lloyd)
- ▶ ABS-certificate (American Bureau of Shipping)
- ▶ CCS-certificate (China Classification Society)
- ▶ pressure port in CuNiFe (sea water resistant)
- ▶ oxygen application



Optional versions

- ▶ IS-version
Ex ia = intrinsically safe
for gases and dusts

The pressure transmitter IMK 457 with ceramic sensor has been designed for typical applications in shipbuilding and offshore constructions as alternative to our pressure transmitter IMP 457 with piezoresistive stainless steel sensor.

In combination with the copper-nickel-alloy the IMK 457 is suitable for seawater, e.g. level measurement in ballast tanks, etc.

Preferred areas of use are

- 
 - Drives
 - Compressors
 - Boiler
 - Pneumatic control systems
 - Oxygen applications
- 
 - Fuel and oil
- 
 - Water and sea water



Input pressure range																		
Nominal pressure gauge [bar]	-1 ... 0	0.4	0.6	1	1.6	2.5	4	6	10	16	25	40	60	100	160	250	400	600
Nominal pressure abs. [bar]	-	-	0.6	1	1.6	2.5	4	6	10	16	25	40	60	100	160	250	400	600
Level gauge / abs. [mH ₂ O]	-	-	6	10	16	25	40	60	100	160	250	400	600	-	-	-	-	-
Overpressure [bar]	4	1	2	2	4	4	10	10	20	40	40	100	100	200	400	400	600	800
Burst pressure ≥ [bar]	7	2	4	4	5	5	12	12	25	50	50	120	120	250	500	500	650	880
Vacuum resistance	p _N ≥ 1 bar: unlimited vacuum resistance p _N < 1 bar: on request																	

Output signal / Supply	
Standard	2-wire: 4 ... 20 mA / V _S = 8 ... 32 V _{DC}
Option IS-version	2-wire: 4 ... 20 mA / V _S = 10 ... 28 V _{DC}

Performance	
Accuracy ¹	IEC 60770: ≤ ± 0.5 % FSO
Permissible load	R _{max} = [(V _S - V _{S min}) / 0.02 A] Ω
Influence effects	supply: 0.05 % FSO / 10 V load: 0.05 % FSO / kΩ
Long term stability	≤ ± 0.3% FSO / year at reference conditions
Response time	< 10 msec

¹ accuracy according to IEC 60770 – limit point adjustment (non-linearity, hysteresis, repeatability)

Thermal effects (Offset and Span) / Permissible temperatures	
Thermal error	≤ ± 0.2 % FSO / 10 K in compensated range 0 ... 85 °C
Permissible temperatures	medium: -40 ... 125 °C electronics / environment: -40 ... 85 °C storage: -40 ... 100 °C

Electrical protection	
Short-circuit protection	permanent
Reverse polarity protection	no damage, but also no function
Electromagnetic compatibility	emission and immunity according to - EN 61326 - DNV•GL (Det Norske Veritas • Germanischer Lloyd)

Mechanical stability	
Vibration	4 g (according to DNV•GL: class B, curve 2 / basis: IEC 60068-2-6)

Materials	
Pressure port	Standard: stainless steel 1.4404 (316L) option ² : CuNi10Fe1Mn (sea water resistant) - for p _N ≤ 400 bar with mechanical connection G1/2" DIN 3852, G1/2" EN 837, G1/2" open port, G1/4" DIN 3852, G1/4" EN 837 - in combination with housing in CuNi10Fe1Mn (not with field housing) -
Housing	standard: stainless steel 1.4404 (316L) option ² : CuNi10Fe1Mn (sea water resistant) - in combination with pressure port in CuNi10Fe1Mn - option field housing: stainless steel 1.4404 (316L); with cable gland (CuNi10Fe1Mn not possible)
Cable sheath	TPE -U (flame-resistant, halogen free, increased resistance against oil and gasoline, resistant against salt, sea water, heavy oil)
Seals (media wetted)	standard: FKM option: FFKM (only for p _N ≤ 100 bar) others on request
Diaphragm	ceramic Al ₂ O ₃ 96 %
Media wetted parts	pressure port, seals, diaphragm

² IS-version on request

Category of the environment			
Lloyd's Register (LR) ³	EMV1, EMV2, EMV3, EMV4		number of certificate: 13/20055
Det Norske Veritas • Germanischer Lloyd (DNV•GL)	temperature:	D	number of certificate: TAA00001GR
	humidity:	B	
	vibration:	B	
	electromagnetic compatibility:	B	
	enclosure:	D	

³ for p_N ≤ 160 bar

Explosion protection			
Approvals DX19-IMK 457	IBExU 10 ATEX 1068 X / IECEx IBE 12.0027X zone 0: II 1G Ex ia IIB T4 Ga zone 20: II 1D Ex ia IIIC T135 °C Da		
Safety technical maximum values	$U_i = 28 \text{ V}$, $I_i = 93 \text{ mA}$, $P_i = 660 \text{ mW}$, $L_i \approx 0 \text{ }\mu\text{H}$ with field housing: $C_i = 105 \text{ nF}$ with cable outlet: $C_i = 84.7 \text{ nF}$ with ISO 4400: $C_i = 62.2 \text{ nF}$ the supply connections have an inner capacity of max. 90 nF (140 nF with field housing) to the housing		
Permissible temperatures for environment	in zone 0: -20 ... 60 °C with p_{atm} 0.8 bar up to 1.1 bar in zone 1 or higher: -40/-20 ... 70 °C		
Connecting cables (by factory)	cable capacitance: signal line/shield also signal line/signal line: 160 pF/m cable inductance: signal line/shield also signal line/signal line: 1 $\mu\text{H}/\text{m}$		
Miscellaneous			
Option oxygen application	for $p_N \leq 25 \text{ bar}$: O-ring in FKM Vi 567 (with BAM-approval) permissible maximum values are 25 bar/150° C		
Current consumption	max. 25 mA		
Weight	approx. 140 g (with ISO 4400)		
Installation position	any		
Operational life	100 million load cycles		
CE-conformity	EMC Directive: 2014/30/EU Pressure Equipment Directive: 2014/68/EU (module A) ⁴		
ATEX-directive	2014/34/EU		
⁴ This directive is only valid for devices with maximum permissible overpressure > 200 bar			
Wiring diagram			
2-wire-system (current)			
Pin configuration			
Electrical connection	ISO 4400 	field housing (clamp section: 2.5 mm ²) 	cable colours (IEC 60757)
Supply +	1	VS+	WH (white)
Supply -	2	VS-	BN (brown)
Shield	ground pin	GND	GYNE (green-yellow)

Electrical connections ⁵ (dimensions mm / in)

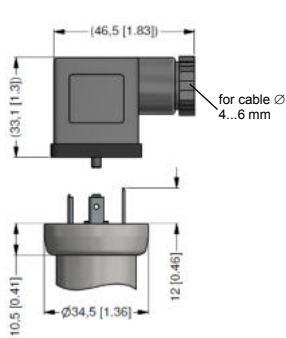

ISO 4400 - Code G10
(IP 65)

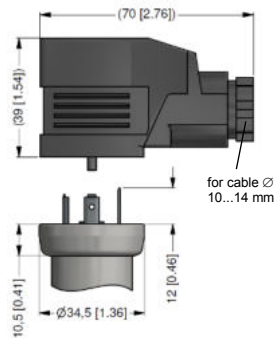

ISO 4400 - Code G00
(IP 65)

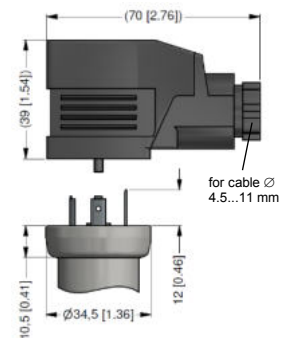

ISO 4400 - Code G01
(IP 65)

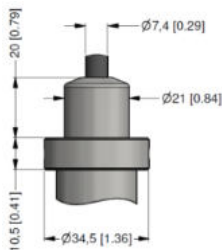

cable outlet ^{6, 7}
(IP 68)

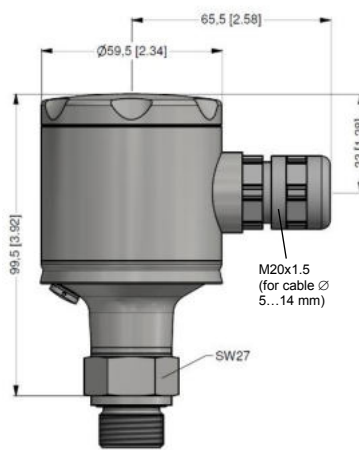

universal field housing
(IP 67)

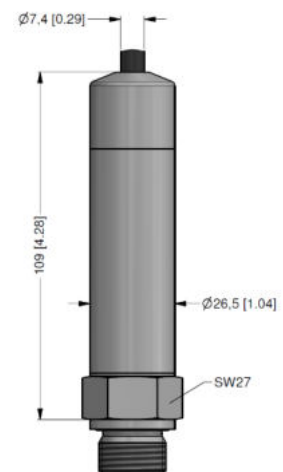

submersible version ⁷
(IP 68)

⁵ Generally shielded cable has to be used! Cable versions are delivered with shielded cable. For ISO 4400 the use of shielded cable is compulsory.

⁶ tested at 4 bar or 40 mH₂O for 24 hours

⁷ shielded cable with integrated air tube for atmospheric reference (for nominal pressure ranges absolute, the air tube is closed); different lengths available

Mechanical connection (dimensions mm / in)

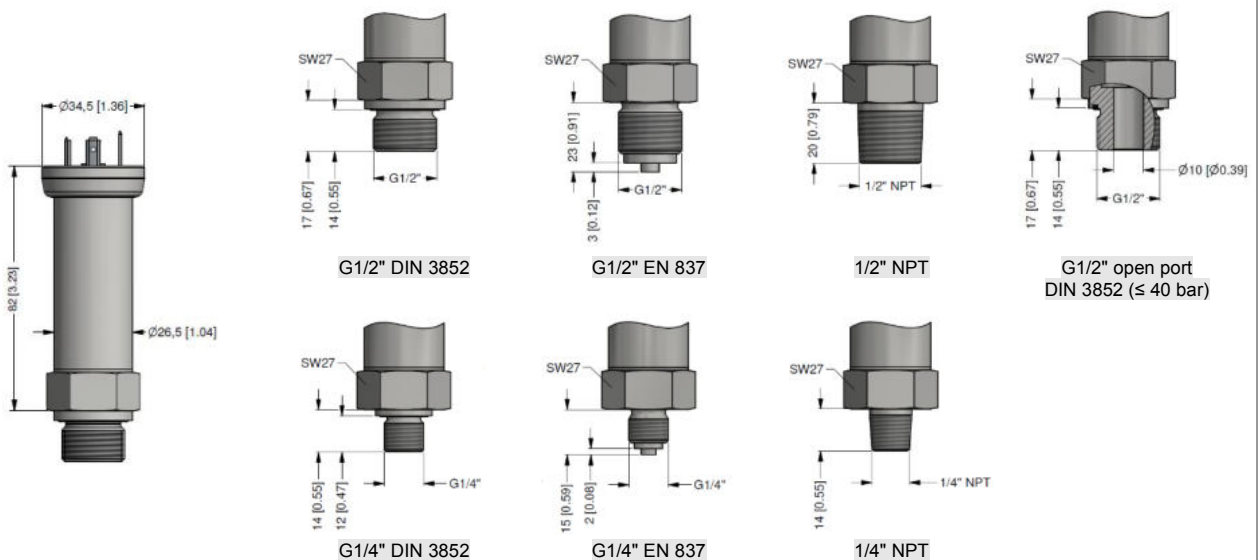

Ordering code IMK 457

IMK 457



Pressure										
	in bar, gauge		5	9	0					
	in bar, absolute ¹		5	9	1					
	in mH ₂ O, gauge		5	9	2					
	in mH ₂ O, absolute ¹		5	9	3					
Input										
	[mH ₂ O]	[bar]								
	4	0.4 ¹	4	0	0	0				
	6	0.6	6	0	0	0				
	10	1.0	1	0	0	1				
	16	1.6	1	6	0	1				
	25	2.5	2	5	0	1				
	40	4.0	4	0	0	1				
	60	6.0	6	0	0	1				
	100	10	1	0	0	2				
	160	16	1	6	0	2				
	250	25	2	5	0	2				
	400	40	4	0	0	2				
	600	60	6	0	0	2				
	100		1	0	0	3				
	160		1	6	0	3				
	250		2	5	0	3				
	400		4	0	0	3				
	600		6	0	0	3				
	-1 ... 0		X	1	0	2				
	customer		9	9	9	9				consult
Output										
	4 ... 20 mA / 2-wire								1	
	intrinsic safety 4 ... 20 mA / 2-wire								E	
	customer								9	consult
Accuracy										
	0.5 % FSO								5	
	customer								9	consult
Electrical connection										
	male and female plug ISO 4400 (for cable Ø 4...6 mm)								G 1 0	
	male and female plug ISO 4400 GL ² (for cable Ø 10...14 mm)								G 0 0	
	male and female plug ISO 4400 GL ² (for cable Ø 4.5...11 mm)								G 0 1	
	cable outlet with TPE-U-cable ³								T R 3	
	field housing stainless steel 1.4404 (316L)								8 8 0	
	submersible version in 1.4404 (316L) with TPE-U-cable ³								T T 3	
	submersible version in CuNiFe with TPE-U-cable ³								T S 3	
	customer								9 9 9	consult
Mechanical connection										
	G1/2" DIN 3852								1 0 0	
	G1/2" EN 837								2 0 0	
	G1/4" DIN 3852								3 0 0	
	G1/4" EN 837								4 0 0	
	G1/2" DIN 3852 open pressure port ⁴								H 0 0	
	1/2" NPT								N 0 0	
	1/4" NPT								N 4 0	
	customer								9 9 9	consult
Seals										
	FKM								1	
	FFKM ⁵								7	
	customer								9	consult
Pressure port										
	stainless steel 1.4404 (316L)								1	
	copper-nickel-alloy (CuNi10Fe1Mn) ⁶								K	
	customer								9	consult
Diaphragm										
	ceramics Al ₂ O ₃ 96 %								2	
	customer								9	consult
Special version										
	standard								0 0 0	
	oxygen application ⁷								0 0 7	
	customer								9 9 9	consult

¹ absolute pressure possible from 0.6 bar

² cable socket is GL-approbated

³ shielded TPE-U-cable with ventilation tube available in different lengths

⁴ only for p_N ≤ 40 bar possible

⁵ only for p_N ≤ 100 bar possible

⁶ optionally for nominal pressure ranges up to 400 bar and mechanical connections G1/2" DIN 3852, G1/2" EN 837, G1/2" open port,

G1/4" DIN 3852, G1/4" EN837 in combination with housing in CuNi10Fe1Mn (not with field housing)

⁷ oxygen application with FKM seal possible up to 25 bar