

## HHR FlowPak® flow meter For applications without straight upstream and downstream pipes Model FLC-HHR-FP

WIKA data sheet FL 10.09

### Applications

- Power generation
- Oil extraction and refining
- Water treatment and distribution
- Gas processing and transmission, LNG, FLNG
- Chemical and petrochemical industries

### Special features

- Highest accuracy and energy efficiency
- No upstream and downstream pipes required
- Wide range of applications



### Description

#### Innovative technology and design

The HHR FlowPak® flow meter is a technological advancement in flow profile formation, redefining performance standards in critical applications.

#### No need for straight upstream and downstream pipes

Independent of the flow profile, no straight upstream and downstream pipes are required. Even installation following two 90° elbows does not represent any problem. Thus the HHR FlowPak® flow meter is the best differential pressure measuring instrument for flow in the entire market for applications with limited mounting space.

#### Maximised performance

Since no additional upstream and downstream pipes are required, the HHR FlowPak® meter has nearly no influence on the flow profile. The pressure loss is reduced to a minimum, providing the highest energy efficiency of all flow measuring instruments, outperforming even Venturi tubes

HHR FlowPak® flow meter, model FLC-HHR-FP

Fig. top: With flange connection

Fig. bottom: With butt weld connection

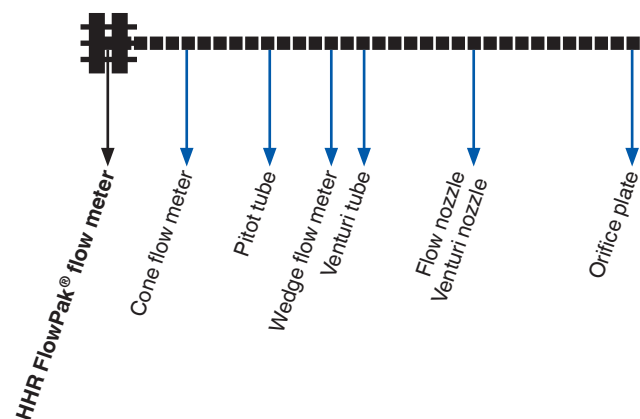

No need for straight upstream and downstream pipes

### Proven performance

The HHR FlowPak® flow meter delivers proven performance, which has been confirmed by extensive laboratory and field testing. Test results of the “Alden Research Laboratory” show the flow coefficient of the HHR FlowPak® to be constant, independent of the Reynolds number and within  $\pm 0.5\%$  of the predicted value, even when installed directly after two elbows out of plane.

This eliminates the need for calibration testing to determine the coefficient and accuracy of each individual flow meter. If a higher accuracy of  $\pm 0.25\%$  or better is desired, the HHR FlowPak® flow meter can be calibrated in a laboratory whose data is NIST certifiable.

### Highest energy efficiency reduces operating costs

Each piece of equipment or pipe integrated into an existing piping system will result in an increase in the pressure loss. With higher pressure losses, pumps and compressors must work harder in order to keep the flow rate stable. Pressure loss is synonymous with higher energy costs that must be spent for normal operation.

The lowest possible pressure loss, thus, assists in reducing the operating costs to a minimum. The HHR FlowPak® flow meter displays the lowest permanent pressure loss of all flow measuring systems with constrictions. The smoothest possible inlet contour and surface together with the unique design of the diffuser section ensures pressure recovery optimisation.

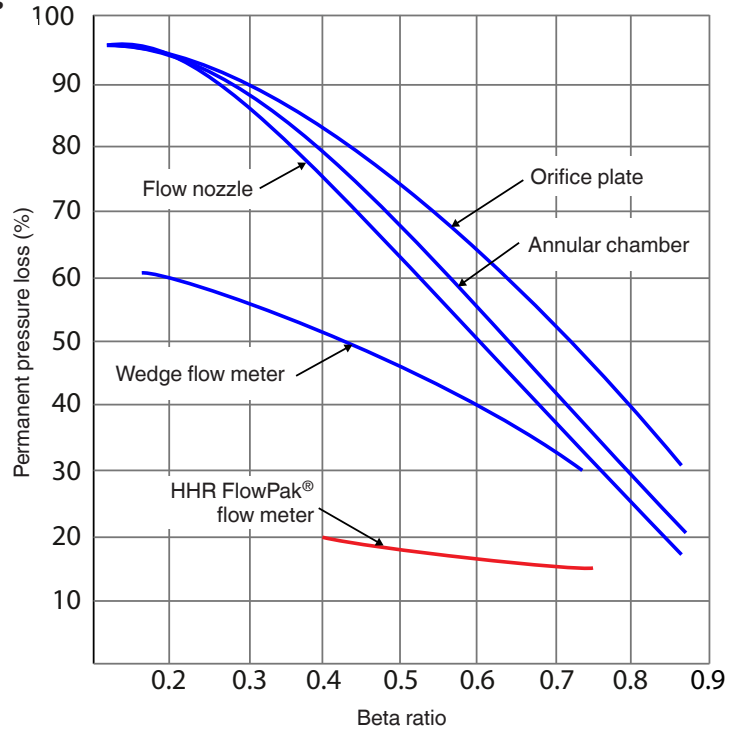

### Developed for superior applications

The unique design ensures that a flow velocity profile is well developed and clearly defined prior to measurement. Extensive tests by the “Alden Research Laboratory” showed consistently high accuracy and repeatability without the need for additional upstream and downstream pipes. With these tests, two closely coupled 90° elbows out of plane were used directly before and after the flow meter. Thus, the HHR FlowPak® flow meter is suitable for pipeline systems with tight mounting space (new construction or retrofit). This can result in significant cost savings in larger, more expensive pipeline systems.

## Specifications

Specifications	HHR FlowPak® flow meter	Annular chamber
Uncalibrated accuracy	±0.5 %	Calibration necessary
Flow coefficient (KV value)	0.985	0.75 ... 0.85
Repeatability	±0.1 %	±0.1 %
Adjustment ratio	Limited only by the lower limit of the Reynolds number	10:1
Requirements for upstream and downstream pipes	none	Depending on beta ratio in accordance with reference Standard, up to 75 D
Nominal size	3 ... 48"	½ ... 120"
Beta ratio	0.4 ... 0.75	0.45 ... 0.85
Number of pressure tapplings	4 sets	1 set
Permanent pressure loss	15 ... 20 %	Varies with beta ratio and differential pressure, typ. 25 ... 75 %
Pipe connections	Welding neck flange Butt weld seam	Welding neck flange Butt weld seam Wafer connection Saddle flange

### Nominal size and pipe schedule

All nominal sizes are available in accordance with relevant standards. The pipe schedule must be specified by the customer.

Standards cover diameters from 3 ... 48" (80 ... 1,200 mm), larger diameters are available on request.

### Nominal pressure rating

Available in accordance with all relevant standards.

### Materials

A wide variety of materials is available.

### Mounting options

Butt weld seam

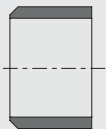

Welding neck flange

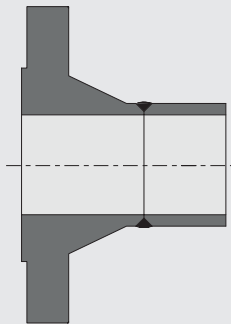

### Pressure tapplings

NPT as standard, others on request.

NPT tap / weld stub

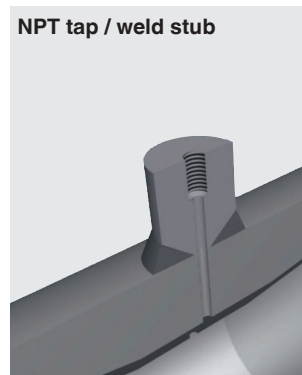

Tap with flanged ends



Annular chamber tap as welded ring

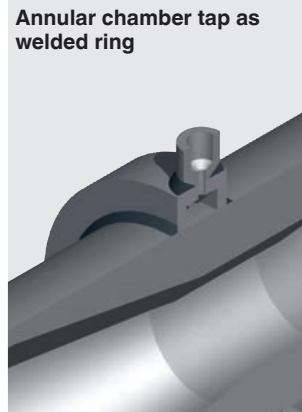

Annular chamber tap from pipes

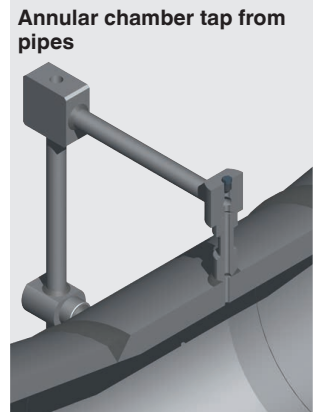

## Dimensions in inch

Nominal size	Inner diameter	Beta ratio	Overall length <sup>1)</sup>	Overall weight (kg)	
				Butt weld seam	Welding neck flange
3	3.068	0.7	18.00	50	50
4	4.026	0.7	22.00	50	100
6	6.065	0.7	32.00	100	150
8	7.981	0.7	42.00	150	200
10	10.020	0.7	52.00	250	350
12	12.000	0.7	60.00	350	500
14	13.250	0.7	68.00	450	650
16	15.250	0.7	78.00	600	850
18	17.250	0.7	86.00	800	1,050
20	19.250	0.7	96.00	1,000	1,300
24	23.250	0.7	114.00	1,550	2,000

1) Shorter lengths on request

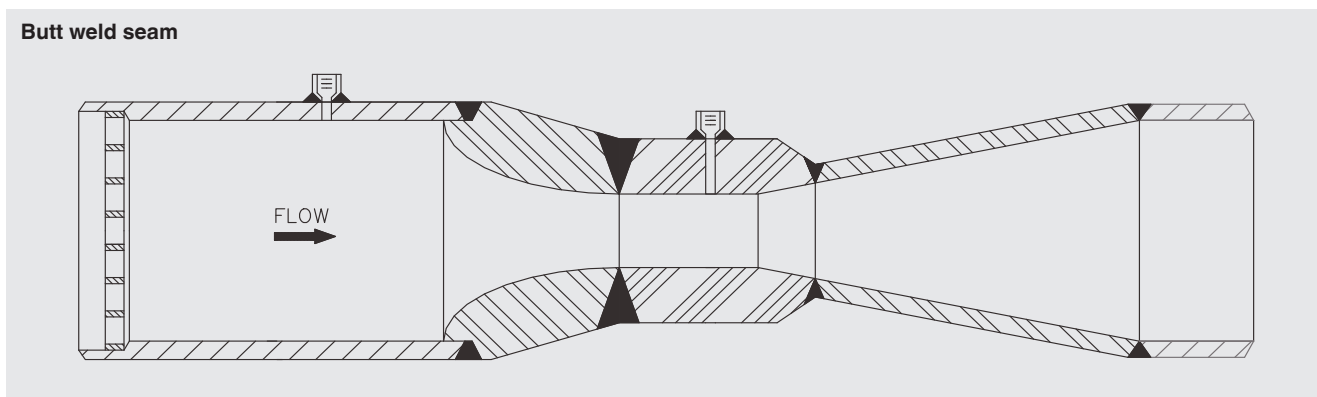
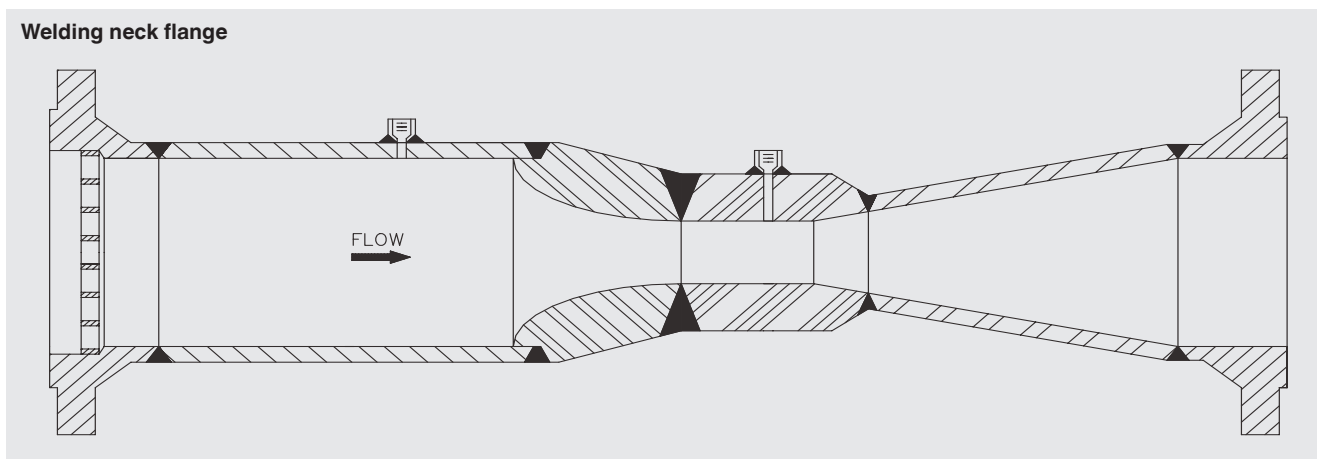

© 03/2017 WIKA Alexander Wiegand SE & Co. KG, all rights reserved.  
 The specifications given in this document represent the state of engineering at the time of publishing.  
 We reserve the right to make modifications to the specifications and materials.