

Primary standard differential pressure balance

Model CPB6000DP

Applications

- High-level primary standard
- Test and calibration of differential sensors and transmitters
- Positive or negative differential pressure
- Cross-float measurement for piston-cylinder system effective area determination

Special features

- Measuring range (= static pressure + differential pressure) up to 800 bar / 11,600 psi pneumatic
- Total measurement uncertainty to 0.008 % of differential pressure plus 0.0001 % (1 ppm) of static pressure
- COFRAC calibration certificate included as standard
- High long-term stability with recommended recalibration cycle every five years
- DP from 10 Pa up to 800 bar / 0.04 inH₂O up to 11,600 psi with static pressure effects down to 1 ppm



Primary standard differential pressure balance, model CPB6000DP

Description

Reference primary standards

Pressure balances are high precision fundamental pressure standards that define the derived unit of pressure directly from the fundamental units of mass, length and time following the formula $p = F/A$.

The direct measurement of the pressure with a pressure balance combined to the know-how of Desgranges & Huot guarantee the best metrological specifications on the market.

- High-quality piston-cylinder units (high floating time and long-term stability)
- Cast aluminium case and robust sub-assemblies (minimum maintenance and overhaul services)

The CPB6000DP is designed for differential pressure calibration and high static line pressure and consists of dual liquid lubricated gas type pressure balances.

A CPB6000DP balance is the combination of two CPB6000-PX balances:

- Integrated into one common case to facilitate operation and improve measurement.
- Built-in pressure controls are provided
- One side of a CPB6000DP can also be used as a CPB6000-PX for gauge pressure calibrations

Application

The pressure balances of the series CPB6000 are applicable in a very wide variety of pressure calibration and measurement tasks. Appropriate configurations are available for use in primary standards laboratories and as reference instruments on the shop floor.

Operating principle

The CPB6000DP consists of two piston-cylinder units. One piston-cylinder unit measures the static pressure in the system and the other one measures the differential pressure. For measuring the differential pressure, a piston-cylinder system with a minor manufacturing tolerance and a high repeatability is required in order to achieve a low measurement uncertainty.

The test procedure is as follows: First the same static pressure is generated at both piston-cylinder systems. Next, as many fine increment masses are applied on the piston-cylinder system measuring the static pressure until both pistons are in their middle floating position. Following this, both piston-cylinder systems are isolated from each other, and the masses generating the differential pressure are applied on the second piston. Both systems are now maintained in their floating positions with the help of the volume slide. This procedure compensates for any diaphragm movement of the test item generated by the pressure.

The exceptional intrinsic characteristics of the piston cylinders make it possible to provide and maintain a static pressure with high precision. The stability of the static pressure is much better than the measurement uncertainty of each of the two cross-sectional areas of the pistons.

Easy operation

The pressure setting is done from external pressure supply via a metering valve. For fine adjustment, a very precisely-controllable spindle pump is fitted, with a precision spindle running within it. As soon as the measuring system reaches equilibrium, there is a balance of forces between the pressure and the mass load applied. The excellent quality of the system ensures that this pressure remains stable over several minutes, so that the pressure value for comparative measurements can be read without any problems, or also so that more complex adjustments can be carried out on the test item.

Measurement uncertainty

As with all Desgranges & Huot pressure balances, this is defined as the difference between the measured pressure and the true value, and includes all possible sources of uncertainty.

The uncertainty with which the differential pressure may be defined depends upon three separate terms:

- Function of piston-cylinder-system: sensitivity piston-cylinder system that has been determined in Desgranges & Huot laboratories.

- Contingent error on the equilibrium between the comparison and measuring piston. This term is a function of the static pressure.
- Uncertainty on the effective area and masses on the piston-cylinder system.

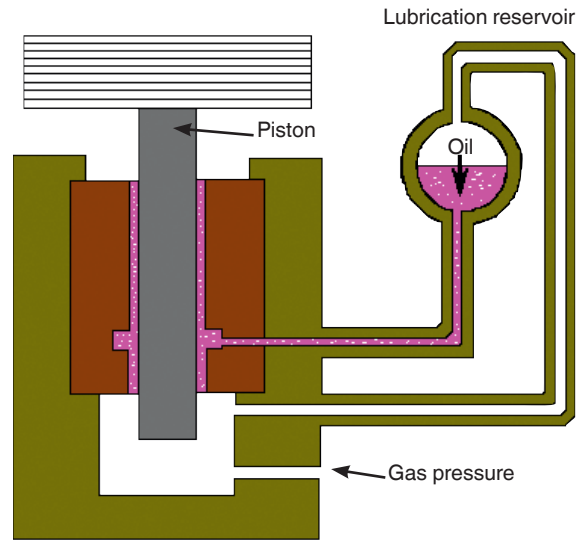

Oil lubricated piston cylinder principle

Stability of the differential pressure

Today's sophisticated differential pressure transmitters and transducers offer resolutions makes it possible to observe the stability with which a floating piston controls a pressure. The "noise" in the two pressures defined by the two pistons of a CPB6000DP pressure balance may appear large relative to the differential pressure even though it is extremely small relative to the static pressure.

Indeed, controlling a differential pressure of 8 mbar ... 100 bar / 0.116 ... 1,450 psi with a stability of 8 Pa means controlling two independent pressures (nominally 100 bar / 1,450 psi on the low side and 100.01 bar / 1,451.45 psi on the high side) within 1 part per million.

Generally, when the pistons of a CPB6000DP pressure balance are rotating freely the noise on the differential pressure will be less than the static pressure effect's contribution to the uncertainty statement.

This "noise", however, will be cyclical and consistent in nature at roughly the same frequency as the rate of rotation of the pistons except when the piston drive mechanism gives the piston an impulse. If the cyclical noise from free piston rotation is averaged and the spikes from the piston drives discarded, a precision well inside the uncertainty statements can be obtained. When calibrating high-resolution test items with rapid response times, users that follow these recommendations report that the achievable precision is three to four times greater than the uncertainty claimed.

The piston-cylinder system assembly

Protecting the piston

In order to avoid risk of interference with the piston's vertical mobility, the masses must be loaded directly onto the piston.

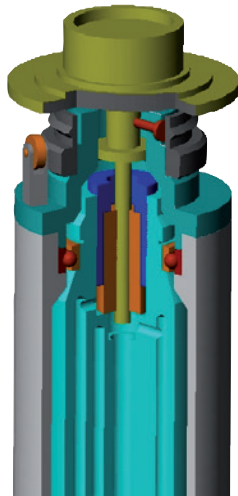

Piston-cylinder system assembly

This is accomplished by loading the masses onto a mass loading bell that rests directly on a plate into which the piston is fitted. When the piston is floating the piston and the mass load are completely free and there is no possibility of unintended friction or interference with their free movement.

When the piston is at the bottom of its stroke the piston plate rests on the drive pulley and rotates with it. When the piston is at the top of its stroke, the piston plate's movement is arrested by three travel limit pins that are set into the pulley. In either position, even if the motor is on and the piston is rotating, there is no friction point.

Maximum mass can be loaded with no pressure applied or maximum pressure can be applied with no mass loaded without risk of damage to the instrument or injury to the operator.

Lubrication mode

There are two main types of measuring posts:

- Free deformation mode
- Re-entrant mode

The re-entrant measuring post accepts piston-cylinder systems with nominal diameter from 1.6 ... 11.2 mm.

Piston-cylinder systems inter-changeability

Numerous inter-changeable piston-cylinder systems are available for each type of CPB6000 making possible multiple ranges with a single instrument. In all cases, changing the piston-cylinder systems requires no major disassembly. The only tool used is a special tool supplied with the standard. The maximum time required to change a piston-cylinder system is less than 1 minute.

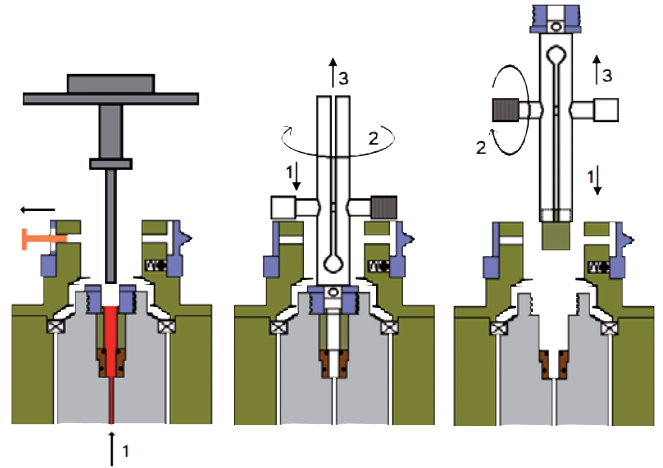

Changing the piston-cylinder system

Kn conversion factor

What is the Kn factor?

All piston-cylinder units and masses mountable on CPB6000 pressure balances are built around a nominal mass to pressure conversion coefficient K_n . The nominal effective area of each piston-cylinder size is such that, under standard conditions, the piston loaded with 1 kg of mass will generate a pressure equivalent to the K_n value.

All mass values, including the mass of the piston and of the mass loading bell are adjusted to be a whole number or fraction of the kilogram.

The nominal pressure defined by any model CPB6000 is calculated as K_n multiplied by the mass loaded in kg. Corrections are applied to K_n to calculate the pressure defined within the uncertainty budget of the model CPB6000 used.

The use of K_n and whole number masses in no way affects the traditional pressure equation or the factors that affect a pressure measurement made with a pressure balance. K_n is the basis of a coherent relationship between mass, effective area and pressure throughout the CPB6000 series. It is intended as a tool that reduces operator confusion and errors by simplifying the calculation of mass loads and measured pressures.

The piston cylinder „heart of the system“

The piston-cylinder system is the heart of the pressure balances and the key to its performance.

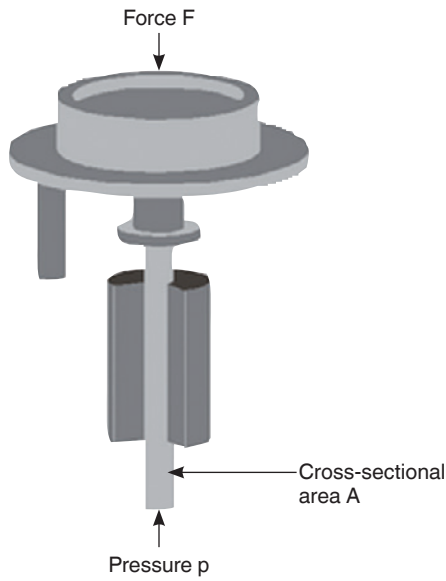

The basic principle of piston-cylinder systems $p = F/A$

Multiple sizes

There are 7 different types of CPB6000 piston-cylinder sizes. This range of sizes includes the largest and the smallest diameters available in high precision pressure balances. The benefit is that it is possible to select the size from a very wide range of sizes, which is suited best for the desired pressure range and further requirements.

Small diameters provide a high pressure to mass ratio which saves the user from having to manipulate excessive amounts of masses and helps to miniaturize the overall system.

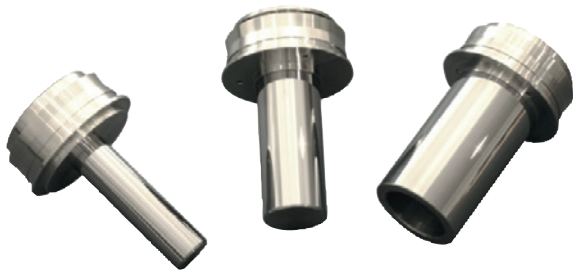

Diverse piston-cylinder systems

Materials and machining

In most cases, both piston and cylinder are made of tungsten carbide which is both extremely hard and wear resistant. Tungsten carbide has a Young's modulus of about $6 \times 10^{11} \text{ N/m}^2$ and a linear thermal expansion coefficient of $4.5 \times 10^{-6}/^\circ\text{C}$. Deformation due to pressure is very low and the effect of temperature is small.

The homogeneity of tungsten carbide permits ultra-precise finishing of the piston-cylinder systems. Deviation from ideal geometry is generally less than 0.1 micron (4 micro-inches). The radial clearance between piston and cylinder can be controlled very closely and varied from about 0.2 ... 1 micron (8 ... 40 micro-inch) depending on the clearance required to achieve optimum performance. The smaller diameter pistons are also available in special tool steel with minimal effect on performance since the most active element is the cylinder, which is always in tungsten carbide.

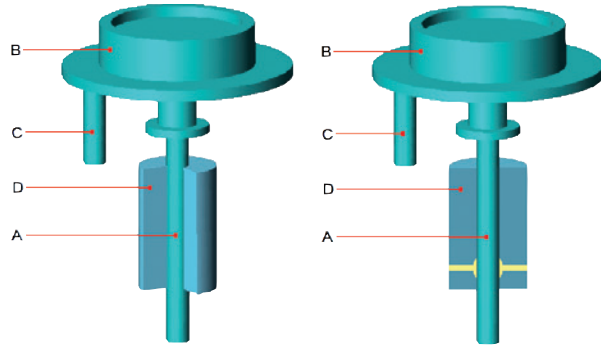

Fig. left: Oil operated piston-cylinder system
Fig. right: Gas operated liquid lubricated piston-cylinder system

- A:** Piston
- B:** Piston head
- C:** Rotation pin
- D:** Cylinder

The mass set

Four different mass sets are available ranging from 1 kg to 40 kg. Masses are machined out of 304 L non-magnetic stainless steel. All individual masses are whole numbers or fractions of the kilogram and are adjusted to their nominal values within the tolerance of their accuracy class. The different accuracy classes are defined as needed to achieve certain nominal accuracies on pressure. Each mass set is delivered in sturdy and attractive cabinets that are easily transportable.

The kilogram

The unit of mass used is always the kilogram because the kilogram is the SI unit and the national and international standard for mass from which all other mass units are derived. The kilogram also offers the convenience of being based on the decimal system, which facilitates mass totalling and data reduction.

Adjustment and interchangeability

Adjusting each mass to its nominal value within the tolerance of its accuracy class allows complete mass interchangeability within one set as well as among different sets. Piston-cylinder systems are not married to specific mass sets. The masses do not need to be loaded in a prescribed sequence. Furthermore, it is not necessary to calculate the mass load in a complex way using different mass values for each mass. Whole number masses are much easier to verify and recalibrate than odd values. The advantages of adjusted masses are great and their use never significantly compromises the uncertainty ultimately achieved on pressure.

Mass set configuration

All mass sets include a number of main masses of 2 or 5 kg as well as 1 kg and fractions of the kilogram down to 0.01 g. All pistons have a mass of 200 g and all loading bells a mass of 800 g. The minimum load then is 200 g and the piston loaded with the bell has a mass of 1 kg. A 5, 4, 2, 1 progression of mass values is used making it possible to load any value desired with a resolution of 0.01 g at any point in the range. Each mass is identified with the mass set serial number as well as with an individual number within the set.

Mass loading

The 5, 2 and 1 kg masses are discs with a central hole which are loaded onto the mass carrying bell. The smaller masses are loaded onto the piston plate. The majority of the load is therefore below the centre of gravity of the piston and the entire load is well centred on the vertical axis of the piston-cylinder system.

Standard composition and custom sets

The composition of the standard CPB6000 mass sets does not include the piston assembly (200 g) and the bell (800 g). Individual masses can be added to a mass set at any time. If so desired, a unique custom mass set may be composed from standard masses.

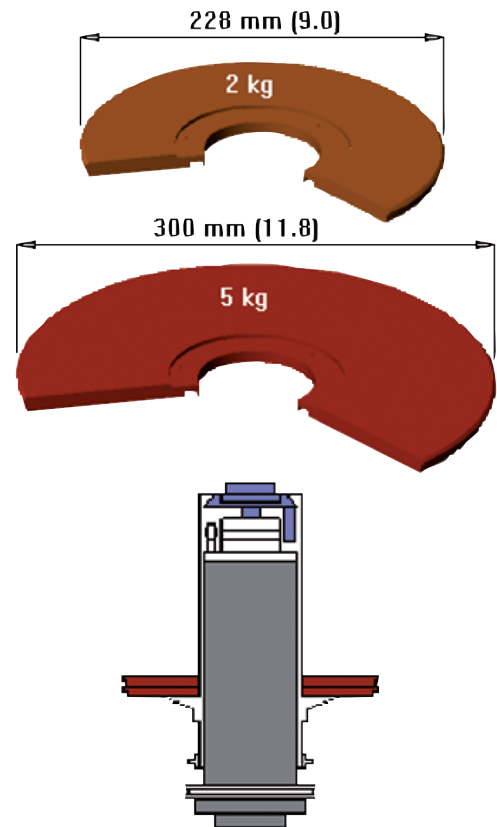

Main masses of CPB6000 mass sets

Reference mass sets

Reference mass sets made up of solid polished masses of the same shape and materials as CPB6000 masses can be supplied. These are convenient as in house standards for local verification or recalibration of CPB6000 mass sets.

Pressure progression

The configuration of the mass sets allows a binary progression.

- First measuring point: piston
- Second measuring point: piston + bell
- Then any point up to full scale with a resolution of 100 mg

CPB6000DP variants and available pressure ranges

Availables ranges

The CPB6000DP's pressure measuring ranges depend on the specific Kn coefficient of the piston-cylinder assembly. Various piston cylinder assemblies can be used with a same CPB6000DP in order to adapt the standard to several applications.

Pneumatic pressure balance with oil lubrication, model CPB6000

Pressure range: up to 800 bar

Mass set: up to 40 kg

Available pressure ranges in bar						Static pressure (SP) Effect ²⁾	Measurement uncertainties ¹⁾ on ΔP	Minimum ΔP range [bar]	Correspondence mass [kg] / pressure [bar]											
Piston-cylinder unit KN	First point [bar]	Complete mass set in kg							Unitary weight in kg											
		1	20	30	40															
		Maximum pressure in bar																		
5 bar/kg	1	5	100	150	200	10 Pa + 1 ppm of SP	0.002 % of ΔP	0.05	25	20	10	5	2.5	1	0.5	0.1	Piston	Bell	Unit	
10 bar/kg	2	10	200	300	400	40 Pa + 1 ppm of SP	0.002 % of ΔP	0.1	50	40	20	10	5	2	1		2	8	bar	
20 bar/kg	4	20	400	600	800	80 Pa + 1 ppm of SP	0.002 % of ΔP	0.2	100	80	40	20	10	4	2		4	16	bar	

Available pressure ranges in psi						Static pressure (SP) Effect ²⁾	Measurement uncertainties ¹⁾ on ΔP	Minimum ΔP range [psi]	Correspondence mass [kg] / pressure [psi]												
Piston-cylinder unit KN	First point [psi]	Complete mass set in kg							Unitary weight in kg												
		1	20	30	40																
		Maximum pressure in psi																			
100 psi/kg	20	100	2,000	3,000	4,000	0.002 psi + 1 ppm of SP	0.002 % of ΔP	0.001	500	400	200	100	50	20	10		20	4	psi		
200 psi/kg	40	200	4,000	6,000	8,000	0.008 psi + 1 ppm of SP	0.002 % of ΔP	0.002	1,000	800	400	200	100	40	20		40	8	psi		
250 psi/kg	50	250	5,000	7,500	10,000	0.009 psi + 1 ppm of SP	0.002 % of ΔP	0.0025	1,250	1,000	500	250	125	50	25		50	16	psi		
300 psi/kg	60	300	6,000	9,000	12,000	0.01 psi + 1 ppm of SP	0.002 % of ΔP	0.003	1,500	1,200	600	300	150	60	30		60	240	psi		

1) The total measurement uncertainty is defined as the uncertainty in measurement attributed via the reference standard uncertainty, influence of environmental conditions, resolution of the instrument, repeatability and hysteresis characteristics during the measurement with the coverage factor k = 2.

2) The static pressure effect is typically defined as A + 1 ppm of ΔP: A being the "noise" of the piston (= pressure perturbation caused by the rotation of the piston), 1 ppm of ΔP being the sensitivity of the pressure balance (= smallest value detectable by variation of the differential pressure).

Specifications Model CPB6000DP

Instrument base	
Pressure transmission medium	Any non-corrosive gas
Lubrication medium	Standard: Drosera™ oil Option: Krytox™ when oxygen compatibility required
Piston-cylinder system	
Pressure ranges	0.2 ... 800 bar / 0.013 ... 11,600 psi
Material	Tungsten carbide
Assembly type	Liquid lubricated gas type (re-entrant)
Piston position monitoring	Standard: Dual mechanical Option: electronic
Mass set	
	Up to 40 kg
Material	AISI316 austenitic, non magnetic stainless steel
Drop rate	approx. 15 minutes (may vary depending on piston cylinder range)
Case	
Dimension (L x W x H)	620 x 500 x 510 mm / 24.4 x 19.4 x 20.1 inch
Weight	45 kg

EC conformity and certificates	
EC conformity	
Pressure equipment directive	97/23/EC (Module A)
Certificate	
Calibration	Standard: COFRAC calibration certificate Option: LNE/PTB calibration certificate

All Desgranges & Huot equipments are delivered with calibration certificate issued by our Cofrac accredited laboratory.

Transport dimensions for complete instrument

The complete instrument, in its standard version and standard scope of delivery, consists of one package for the instrument base with the following dimensions and weights.

Instrument base Model	Box with base and standard accessories Dimensions: 780 x 650 x 750 mm	
	Weight in kg	
	net	gross
CPB6000-DP	85	106

Pneumatic circuit

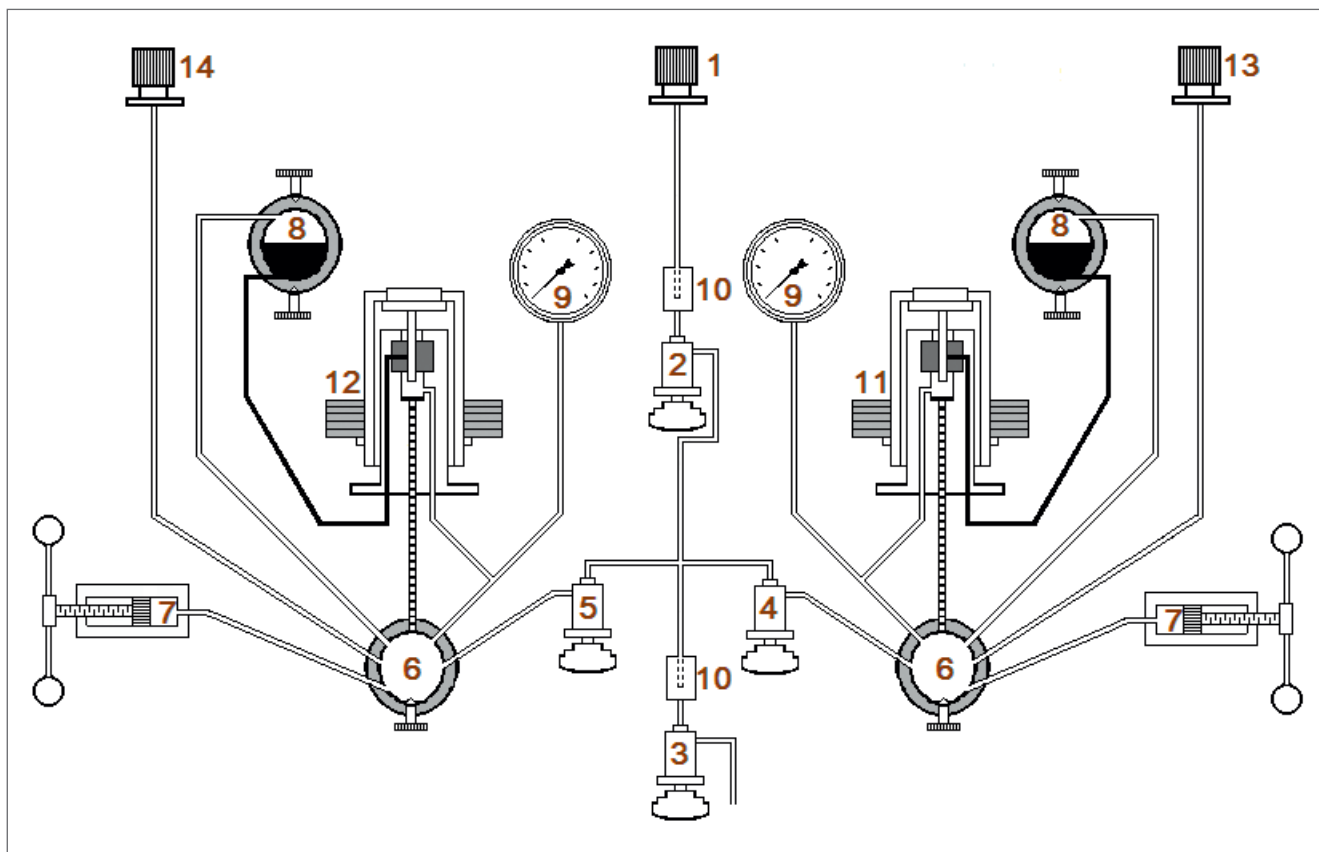

- | | |
|-----------------------------------|---|
| 1 Gas inlet quick connecting head | 8 Visible level lubricant reservoir |
| 2 Inlet valve | 9 Pressure gauge |
| 3 Exhaust valve | 10 Filter |
| 4 HP isolation valve | 11 Measuring piston-cylinder unit (static P + DP) |
| 5 LP isolation valve | 12 Comparison piston-cylinder unit (static P) |
| 6 Pressure manifold/sump | 13 HP pressure connection |
| 7 Variable volume | 14 LP pressure connection |

Dimensions in mm

(without masses)

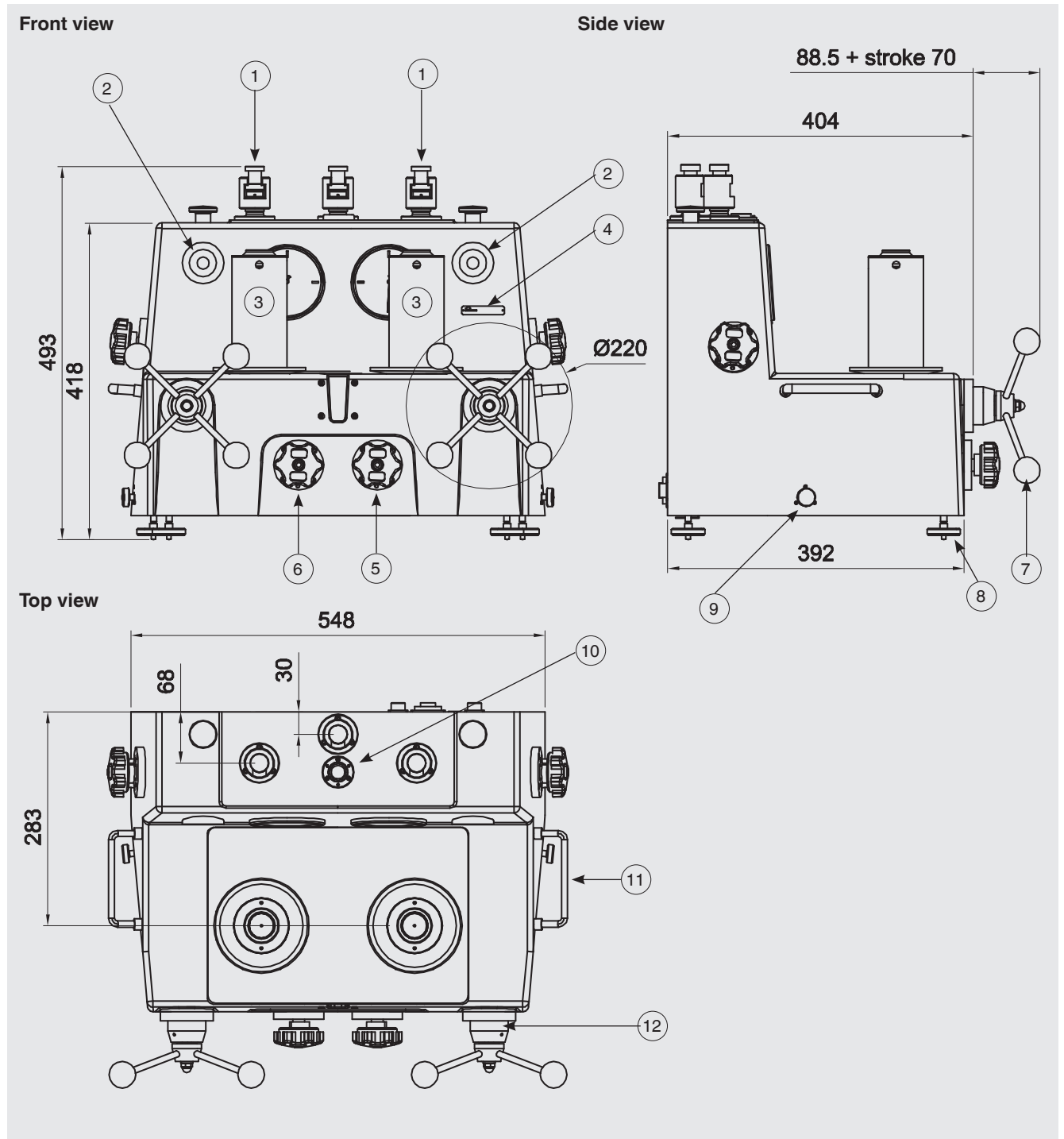

- | | |
|---------------------------------------|----------------------|
| (1) Test item connection | (7) Star handle |
| (2) Oil lubrication visible reservoir | (8) Levelling feet |
| (3) Piston-cylinder system | (9) Sump drain cock |
| (4) Reference level | (10) Level |
| (5) High-pressure shut-off valve | (11) Carrying handle |
| (6) Low-pressure shut-off valve | (12) Variable volume |

Further pressure balances within our calibration technology programme

Primary-standard pressure balance, model CPB6000

Measuring ranges:

- Pneumatic up to 1,000 bar
- Hydraulic up to 5,000 bar

Measurement uncertainty: down to 0.002 % of reading depending on model

For specifications see data sheet CT 32.01



Primary-standard pressure balance, series CPB6000

Automatic pressure balance, model CPB8000

Measuring ranges:

- Pneumatic up to 1,000 bar
- Hydraulic up to 5,000 bar

Measurement uncertainty: 0.005 % of measured value
up to 0.003 % of measured value (optional)

For specifications see data sheet CT 32.03

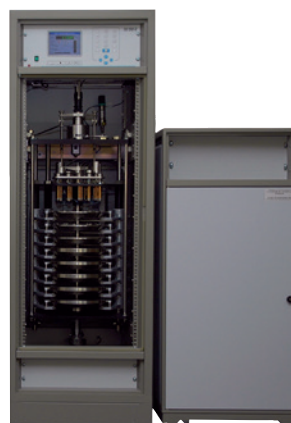

Automatic pressure balance, model CPB8000

Digital pressure balance, model CPD8000

Measuring ranges:

- Pneumatic up to 500 bar

Measurement uncertainty: 0.005 % of measured value
up to 0.002 % of measured value (optional)

For specifications see data sheet CT 32.04



Digital pressure balance, model CPD8000

Scope of delivery

- Base
- Piston-cylinder system with overhang (bell jar)
- Set of masses manufactured to standard gravity (9.80665 m/s²)
- 1 litre of Drosera oils as standard 60 ml of Krytox oil when oxygen compatible version
- Tool and first level maintenance set
- Operating instructions in German and English language
- COFRAC calibration certificate
- Storage case for the base, mass set and piston-cylinder system

Options

- LNE/PTB calibration certificate
- Large choice of pressure adapters
- Gas booster
- Remote piston position monitoring

Ordering information

Model / Instrument version / Accuracy / Set of 2 piston-cylinder assemblies / Set of 2 mass sets / Terminal 5000 / Calibration for differential pressure balance / Additional order information

© 2014 WIKA Alexander Wiegand SE & Co. KG, all rights reserved.
The specifications given in this document represent the state of engineering at the time of publishing.
We reserve the right to make modifications to the specifications and materials.

WIKA data sheet CT 32.02 · 06/2014

Page 11 of 11

Your WIKA Sales Partner



ICS Schneider Messtechnik GmbH

Briesestrasse 59

D-16562 Hohen Neuendorf / OT Bergfelde

Tel.: +49 3303 5040-66

Fax: +49 3303 5040-68

E-Mail: info@ics-schneider.de



WIKA Alexander Wiegand SE & Co. KG

Alexander-Wiegand-Straße 30

63911 Klingenberg/Germany

Tel. +49 9372 132-0

Fax +49 9372 132-406

info@wika.de

www.wika.de