

Pneumatic comparison test pump Model CPP120-X

WIKA data sheet CT 91.03

Applications

- Pneumatic provision of pressure on site, in the laboratory or in the workshop up to 120 bar
- For the testing, adjustment and calibration of all types of pressure measuring instruments

Special features

- Two fine metering valves for pressure inlet and pressure outlet or vacuum
- Precisely adjustable volume adjuster for fine adjustment of pressure
- Proven technology of the dead-weight tester CPB3500
- Connection for external pressure or vacuum source
- Pressure gauge for indicating the approximate pressure



Comparison test pump CPP120-X

Description

Application areas

Test pumps serve as pressure generators for the testing, adjustment and calibration of mechanical and electronic pressure measuring instruments through comparative measurements. These units can be used in the laboratory or workshop, or on site at the measuring point.

Easy operation

By connecting the test item and a sufficiently accurate reference pressure measuring instrument to the test pump, the same pressure will act on both measuring instruments. By comparison of the two measured values at any given pressure value, a check of the accuracy and/or adjustment of the pressure measuring instrument under test can be carried out.

Easy handling

The model CPP120-X comparison test pump is a pneumatic comparison test pump for the provision of pressure up to 120 bar. It is technically identical to the instrument base of the model CPB3500 dead-weight tester.

The individual test points can be easily controlled with the two integrated fine metering valves for pressure inlet and pressure outlet.

For the precise setting for accurate comparative testing, the pump features a precisely adjustable volume adjuster. The connection for the necessary external pressure or vacuum source is located on the rear panel.

The two test connections are equipped with G ½ female loose union connections. Corresponding thread adapters are available for the calibration of instruments with different connection threads.

Compact instrument design

The CPP120-X is also particularly notable for its compact dimensions, which are not altered during operation, since the spindle runs within the pump body.

With those dimensions, the exceptionally robust ABS plastic case and the low weight associated with these, the CPP120-X is also particularly suited for on-site applications.

Specifications	Model CPP120-X
Pressure range	0 ... 120 bar
Pressure transmission medium	Clean, dry, non-corrosive gases (e.g. air or nitrogen)
Pressure connections	
Test item connection	2 x G ½ female thread, loose union connection
Distance between test item connections	290 mm
External pressure connection	G ¼ B female
Material	
Wetted parts	Austenitic stainless steel, high tensile brass, copper, nitrile rubber
Permissible ambient conditions	
Operating temperature	0 ... 40 °C
Instrument base	
Dimensions	510 x 490 x 210 mm (W x D x H), for details, see technical drawings
Weight	22 kg

Recommended reference pressure measuring instruments:

Precision digital pressure gauge model CPG1000

Measuring ranges: up to 700 bar

Accuracy: 0.05 % of span

For further specifications see data sheet CT 10.01



Hand-held pressure indicator model CPH6300

Measuring ranges: up to 1,000 bar

Accuracy: 0.2 % of span

For further specifications see data sheet CT 12.01



Precision hand-held pressure indicator model CPH6400

Measuring ranges: up to 6,000 bar

Accuracy: up to 0.025 % of span

For further specifications see data sheet CT 14.01



ProcessCalibrator model CPH6000

Measuring ranges: up to 8,000 bar

Accuracy: up to 0.025 % of span

For further specifications see data sheet CT 15.01



Dimensions in mm

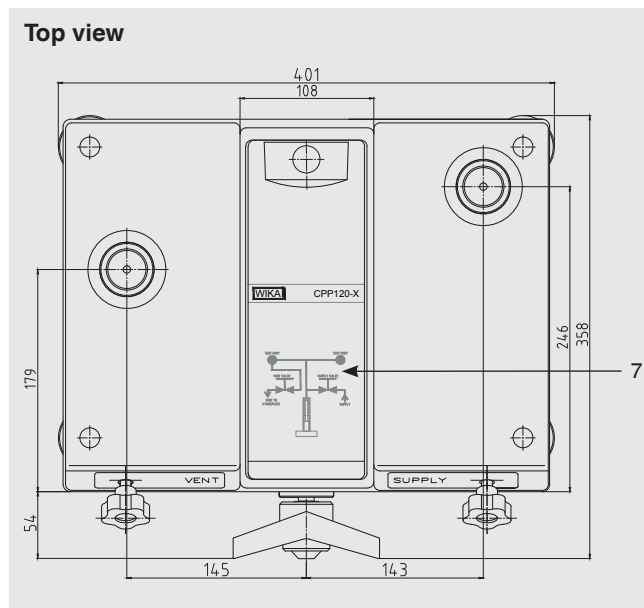
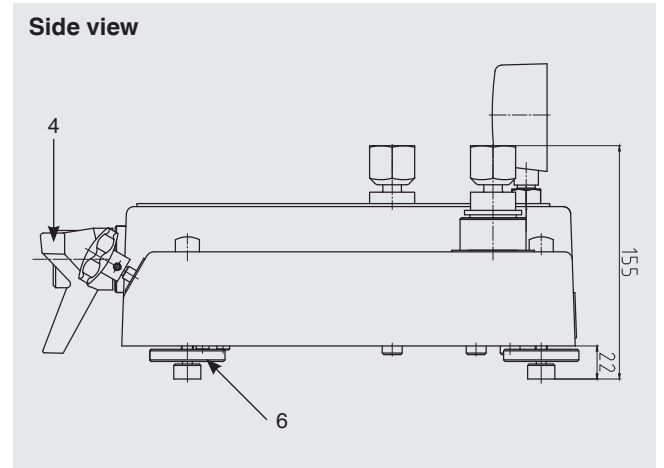
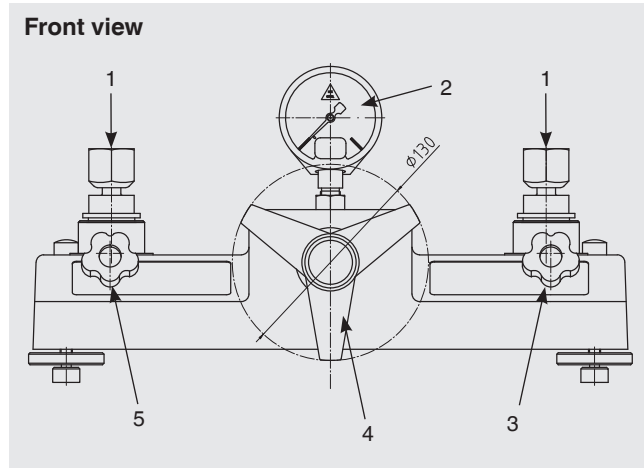

- (1) Test item connection
- (2) Pressure gauge
- (3) Inlet valve
- (4) Volume adjuster with star handle
- (5) Outlet valve
- (6) Rotatable feet
- (7) Pressure generation control schematic

Test item connection

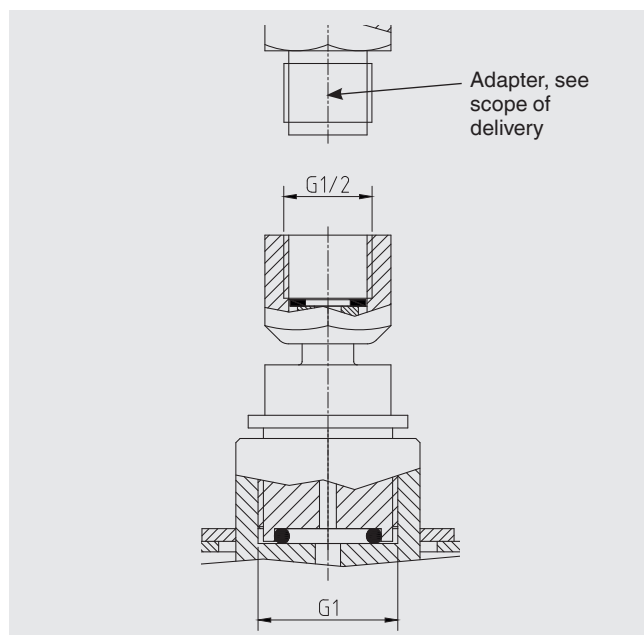

Scope of delivery

- Instrument base
- Two fine metering valves for pressure inlet and pressure outlet or vacuum
- Volume adjuster for fine pressure adjustment
- Two test item connections with G ½ female thread, loose union connection
- Adapter set for test item selectable from 3 different sets:
 - Adapter set "BSP" G ½ male on G ⅛, G ¼, G ⅜ and G ½ female
 - Adapter set "NPT" G ½ male on ⅛ NPT, ¼ NPT, ⅜ NPT and ½ NPT female
 - Adapter set "metric" G ½ male on M12 x 1.5 and M20 x 1.5 female
- Connection for external pressure or vacuum source
- Tool and maintenance set
- Operating instructions in German and English language

Accessories

Adapters and connections

- Adapter set "BSP" for test item connection G ½ B male on G ⅛, G ¼, G ⅜ and G ½ female
- Adapter set "NPT" for test item connection G ½ B male on ⅛ NPT, ¼ NPT, ⅜ NPT and ½ NPT female
- Adapter set "metric" for test item connection G ½ B male on M12 x 1.5 and M20 x 1.5 female
- 90° angle connection, for test items with back mounting connection, NBR sealing
- Test item connection, G 1" male to G ½ female, rotating
- 2-way test item connection, G 1" male to 2 x G ½ female, rotating (model 27)

Tools

- Sealing and maintenance set for instrument base
- Tool set consisting of open-ended spanner, replacement seals, pointer remover and pointer punch

Storage

- Storage case for instrument base CPP120-X

Separator

- Separator 0 ... 35 bar (model 35)

Ordering information

Model / Package / Standard adapter set / Additional adapter set / Angle connection / Storage case / Accessories / Additional ordering information

© 2015 WIKA Alexander Wiegand SE & Co. KG, all rights reserved.
The specifications given in this document represent the state of engineering at the time of publishing.
We reserve the right to make modifications to the specifications and materials.

Your WIKA Sales Partner



ICS Schneider Messtechnik GmbH

Briesestrasse 59

D-16562 Hohen Neuendorf / OT Bergfelde

Tel.: +49 3303 5040-66

Fax: +49 3303 5040-68

E-Mail: info@ics-schneider.de



WIKA Alexander Wiegand SE & Co. KG

Alexander-Wiegand-Straße 30

63911 Klingenberg/Germany

Tel. +49 9372 132-0

Fax +49 9372 132-406

info@wika.de

www.wika.de