

# Diaphragm monitoring system with flange connection For the chemical and petrochemical industries Model DMS27

WIKA data sheet DS 95.23

## Applications

- Chemical/petrochemical industry, oil/gas industries
- For applications with hydrofluoric acid content
- For Ex applications
- For aggressive and critical media
- Pressure/vacuum measurement on pipelines or vessels

## Special features

- Double-diaphragm system to ensure the separation of the process and the pressure measuring instrument
- Process connection with flange to provide for direct threaded connection
- All welded design with flush diaphragm
- Wetted parts from Hastelloy



Diaphragm monitoring system, model DMS27

## Description

The WIKA combination of diaphragm seal, pressure measuring instrument and monitoring element is ideally suited for the harshest measuring tasks. The system can withstand aggressive or hot media.

The patented diaphragm monitoring has been designed specifically for the highest safety requirements in the chemical and petrochemical industries.

On the double-diaphragm system a second, internal diaphragm in the pressure measuring instrument ensures the reliable separation of the environment and the process in the event of a diaphragm rupture. The measuring function of the overall system remains unrestricted, nevertheless it must be replaced immediately.

Mounting of the diaphragm seal to the pressure measuring instrument is made as direct mounting as standard. A fluid inside the system, which is explicitly chosen to suit the particular application, hydraulically transmits the pressure to the pressure measuring instrument.

Diaphragm monitoring systems with the WIKA model 990.27 diaphragm seals are used successfully in applications with hydrofluoric acid content.

The model DMS27 is a patented WIKA development, see e.g. patent DE 19949831, and is subject to further pending patents, e.g. US 2018180505, DE 102016015447, CN 108240885.

## Illustrative example of a diaphragm monitoring system

The diaphragm monitoring system is a combination of pressure measuring instrument and diaphragm seal with an additional monitoring element for the diaphragm condition.

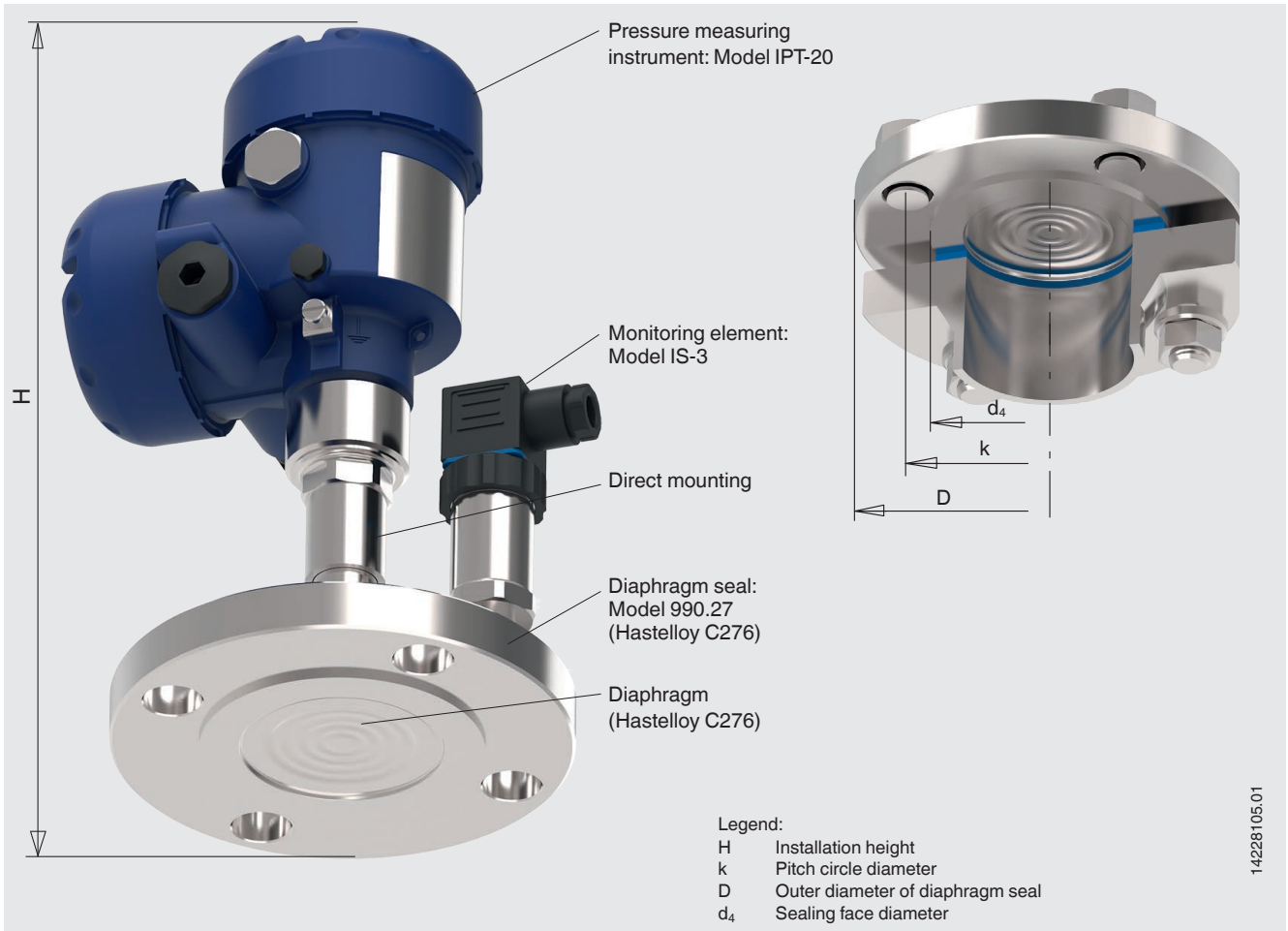

## Functional principle of diaphragm monitoring

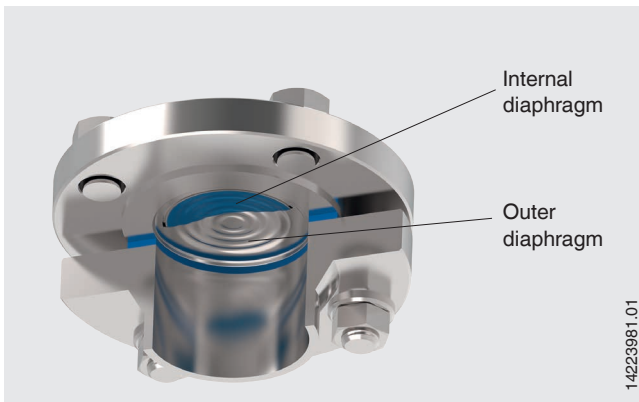

WIKA's double-diaphragm design is the solution for critical processes where neither the medium should find its way into the environment, nor should the system fill fluid find its way into the product.

### Normal operation

In normal operation, the pressure measurement and the diaphragm monitoring operate without limitations within the performance limits of the overall system design. The space between the two diaphragms is evacuated. This vacuum is measured with the monitoring element and the diaphragm condition is monitored.

### Diaphragm rupture

In the event of a diaphragm rupture, the pressure monitored in the intermediate space increases. As soon as the current output signal of the monitoring element exceeds the adjusted setpoint, an electrical alarm signal is issued. This signals a diaphragm rupture.

### Safety

The measuring technology of the monitoring element withstands the process pressure despite the diaphragm rupture. The measuring function of the overall system remains unrestricted. The process reliability is guaranteed because the materials of the two diaphragms are made of the same material as the wetted parts of the diaphragm seal. The overall system is, nevertheless, damaged and must be replaced immediately.

# Specifications

Diaphragm seal system	
<b>Design</b>	Process transmitter mounted to a diaphragm seal with flange connection, welded
<b>Measuring range</b>	
Gauge pressure	0 ... 2.5 bar [0 ... 40 psi]    0 ... 4 bar [0 ... 60 psi]    0 ... 6 bar [0 ... 100 psi]    0 ... 10 bar [0 ... 150 psi] 0 ... 16 bar [0 ... 250 psi]    0 ... 25 bar [0 ... 400 psi]    0 ... 40 bar [0 ... 600 psi]
Vacuum <sup>1)</sup>	-1 ... +1.6 bar [-30 inHg ... +25 psi]    -1 ... +3 bar [-30 inHg ... +45 psi] -1 ... +5 bar [-30 inHg ... +70 psi]    -1 ... +10 bar [-30 inHg ... +145 psi] -1 ... +15 bar [-30 inHg ... +220 psi]    -1 ... +25 bar [-30 inHg ... +360 psi]
<b>Permissible temperature range</b>	
Medium	-10 ... +120 °C [-50 ... +248 °F]
Ambient	10 ... 40 °C [50 ... 104 °F]
Storage	10 ... 60 °C [50 ... 140 °F]
<b>Ingress protection per IEC/EN 60529</b>	IP65
<b>Material <sup>2)</sup></b> wetted	Diaphragm: Hastelloy C276 2.4819; UNS N10276 Diaphragm seal: Hastelloy C276 2.4819; UNS N10276
<b>Mounting type</b>	Direct mounting
<b>Level of cleanliness of wetted parts</b>	Oil and grease free per ASTM G93-03 level F WIKA standard (< 1,000 mg/m <sup>2</sup> )
<b>System fill fluid</b>	KN 21 halocarbon

1) Under vacuum, the diaphragm monitoring is only possible to a limited extent

2) Other materials on request

Monitoring element <sup>3)</sup>	Absolute pressure sensor (Model IS-3)
<b>Current output</b>	4 ... 20 mA (2-Leiter)
<b>Signal behaviour</b>	0 bar abs. → Outer diaphragm intact    Signal: 4 mA ≥ 0,8 bar abs. → Outer diaphragm defective    Signal: > 4 mA (depending on the pressure measuring range of the absolute pressure sensor)
<b>Power supply</b>	DC 10 ... 30 V
<b>Permissible load in Ω</b>	≤ (power supply - 10 V) / 0.02 A - (cable length in m x 0.14 Ω)
<b>Material</b>	
Case	Stainless steel
Wetted parts <sup>4)</sup>	Hastelloy
Angular connector DIN EN 175301-803 A	PA6
<b>Ingress protection per IEC/EN 60529</b>	IP65

3) In the event of a diaphragm rupture, the diaphragm monitoring is specified for process pressures ≥ 0 bar rel.

4) In the event of a diaphragm rupture of the outer diaphragm

For further information on model IS-3 see data sheet PE 81.58

**Pressure measuring instrument: Process transmitter model IPT-20**

<b>Output signal</b>	4 ... 20 mA 4 ... 20 mA with a superimposed HART® communication signal (option: SIL qualification) HART® specification: 7.3 FOUNDATION™ Fieldbus PROFIBUS® PA
<b>Load in <math>\Omega</math></b>	$(U_B - U_{Bmin}) / 0.023 \text{ A}$  $U_B$ = Applied power supply (see table "Power supply") $U_{Bmin}$ = Minimum power supply (see table "Power supply")
<b>Accuracy at room temperature <sup>1)</sup></b>	Measuring ranges $\leq 40$ bar: $\leq 0.1$ % of span
<b>Material (non-wetted)</b> Case Sensor	Double chamber case, aluminium die-casting AlSi10Mg, powder-coated on PE basis Stainless steel 316L/1.4404
<b>Display</b>	LC display with backlighting, can be fitted on the top or on the side
<b>Ingress protection per IEC/EN 60529</b>	IP66 / IP67

1) Including non-linearity, hysteresis, zero offset and end value deviation (corresponds to measured error per IEC 61298-2). Calibrated in vertical mounting position with process connection facing downwards.

For further information on model IPT-20 see data sheet PE 86.06

**Diaphragm seal: Model 990.27**

<b>Type of process connection</b>	Flange connection DN 2" Class 150, following ASME B16.5
-----------------------------------	---

Dimensions in mm [in]

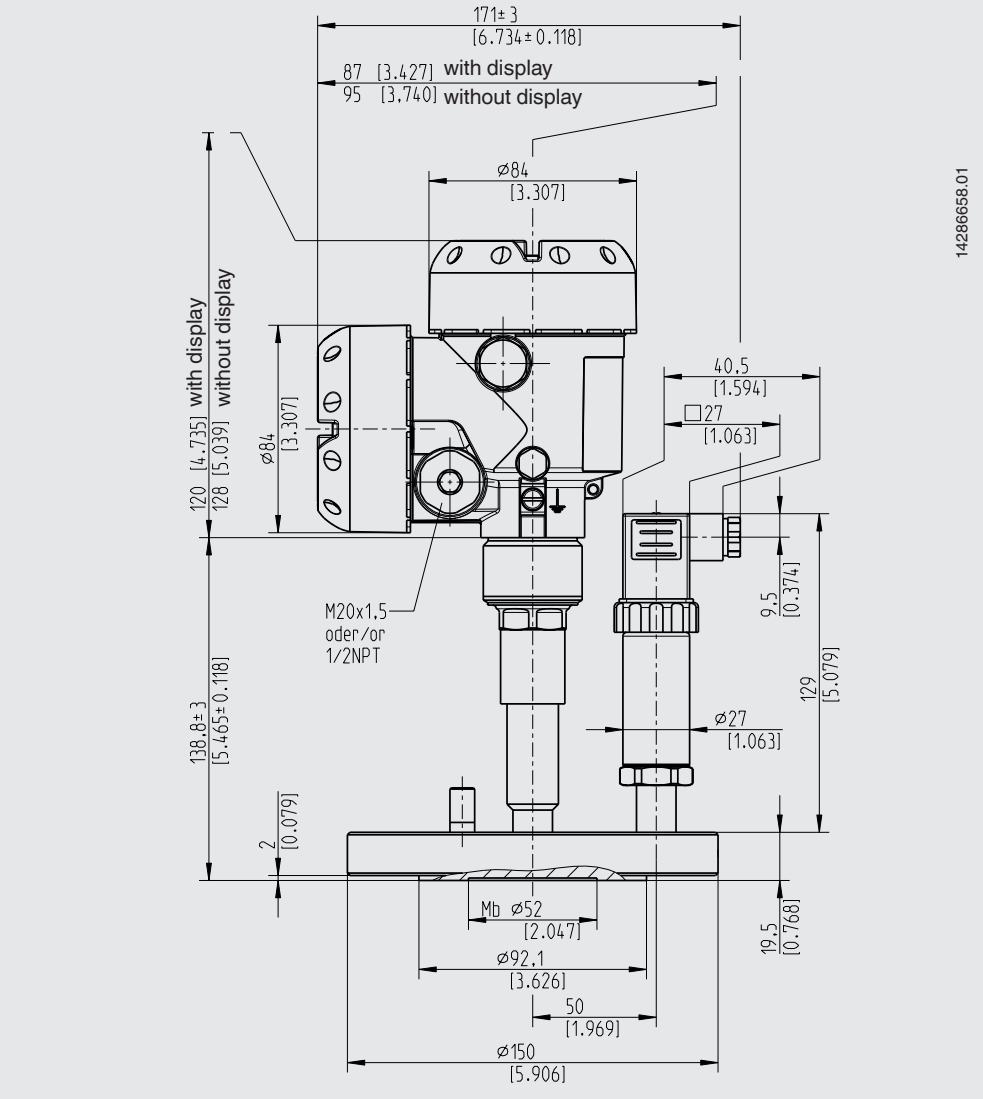

Other versions on request

## Certificates (option)

- 2.2 test report per EN 10204  
(e.g. surface finish quality of wetted parts)
- 2.2 certification per NACE MR 1705 and MR 103
- 3.1 inspection certificate per EN 10204  
(e.g. material proof, wetted metal parts with suppliers' certificate (melting analysis), measurement accuracy: Listing of the single measured values)
- Others on request

## Patents, property rights

- Diaphragm monitoring for diaphragm seals  
(US 2018180505, DE 102016015447,  
CN 108240885, NL 2019251)
- Diaphragm of diaphragm seal (DE19949831)

Approvals and certificates, see website

© 05/2017 WIKA Alexander Wiegand SE & Co. KG, all rights reserved.  
The specifications given in this document represent the state of engineering at the time of publishing.  
We reserve the right to make modifications to the specifications and materials.