

Diaphragm seal for flange connection Thread-type with extended diaphragm, urea applications Model 990.49

WIKA data sheet DS 99.46

Applications

- Aggressive, crystallising, corrosive or hot media
- Fertiliser industry
- Urea applications
- Thick-walled or insulated pipelines and vessels

Special features

- Threaded diaphragm seal with extended welded diaphragm
- Special steel alloy for urea synthesis
- Dimensions following Snamprogetti® standard ¹⁾



Diaphragm seal for flange connection, model 990.49

Description

Diaphragm seals are used for the protection of pressure measuring instruments in applications with difficult media. In diaphragm seal systems, the diaphragm of the diaphragm seal effects the separation of the instrument and the medium. The pressure is transmitted to the measuring instrument via the system fill fluid which is inside the diaphragm seal system.

For the implementation of demanding customer applications, there are a wide variety of designs, materials and system fill fluids available.

For further technical information on diaphragm seals and diaphragm seal systems see IN 00.06 "Application, operating principle, designs".

The model 990.49 diaphragm seal is designed to be screwed into a threaded flange. Due to the extended diaphragm, the diaphragm seal can be used at thick-walled or insulated locations in pipeline and vessel construction.

Mounting of the diaphragm seal to the measuring instrument may be made via a direct connection, for high temperatures via a cooling element or via a flexible capillary.

For this model, WIKA offers a special steel alloy which is primarily used in the fertiliser industry.

¹⁾ Snamprogetti® is a registered trademark of Saipem S.p.a.

Specifications

Model 990.49	Standard	Option
Pressure/temperature operating limit	<ul style="list-style-type: none"> ■ 221 bar [3,205 psi] / 250 °C [482 °F] ■ 268 bar [3,887 psi] / 160 °C [320 °F] ■ 292 bar [4,235 psi] / 80 °C [176 °F] 	on request
Material	see material design page 3	Material test according to Snamprogetti® specification CR.UR.510 rev.3 from RTM BREDA S.r.l.
Level of cleanliness of wetted parts	Oil and grease free per ASTM G93-03 level F WIKA standard (< 1,000 mg/m ²)	<ul style="list-style-type: none"> ■ Oil and grease free per ASTM G93-03 level D and ISO 15001 (< 220 mg/m²) ■ Oil and grease free per ASTM G93-03 level C and ISO 15001 (< 66 mg/m²)
Origin of wetted parts	International	<ul style="list-style-type: none"> ■ EU ■ CH ■ USA
Connection to the measuring instrument	Axial adapter	Axial adapter with G ½, G ¼, ½ NPT or ¼ NPT (female)
Type of mounting	Direct mounting	<ul style="list-style-type: none"> ■ Capillary ¹⁾ ■ Cooling element
Threaded flange	-	Stainless steel 1.4435 (316L)
Vacuum service (see IN 00.25)	Basic service	<ul style="list-style-type: none"> ■ Premium service ■ Advanced service
Instrument mounting bracket (only for capillary option)	-	<ul style="list-style-type: none"> ■ Form H per DIN 16281, 100 mm, aluminium, black ■ Form H per DIN 16281, 100 mm, stainless steel ■ Bracket for pipe mounting, for pipe Ø 20 ... 80 mm, steel (see data sheet AC 09.07)

1) Limited to max. 2 metres

Example: Diaphragm seal model 990.49 with mounted pressure switch and optional threaded flange

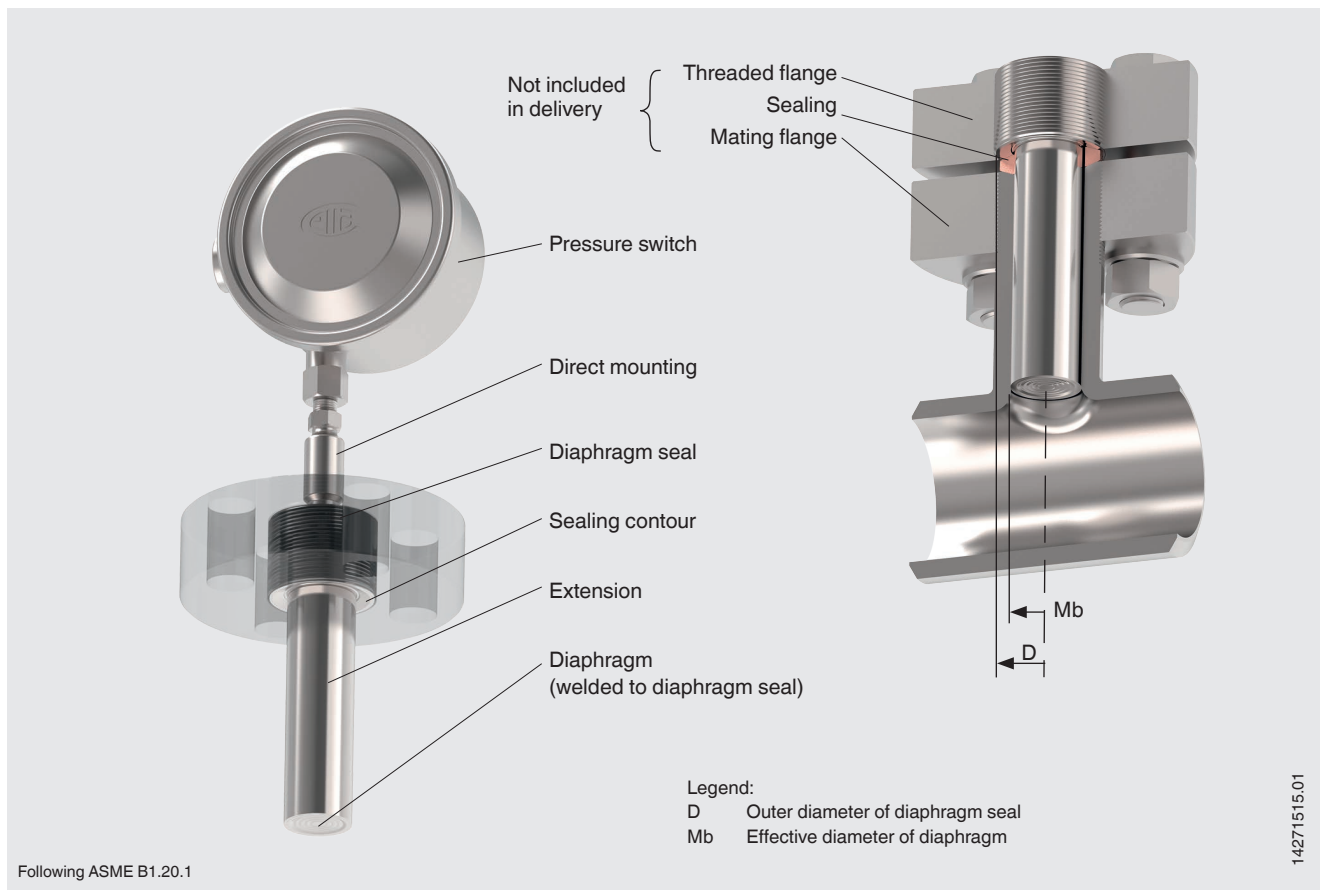

Dimensions in mm [in]

Threaded connection following NPSM pipe thread, ASME B1.20.1

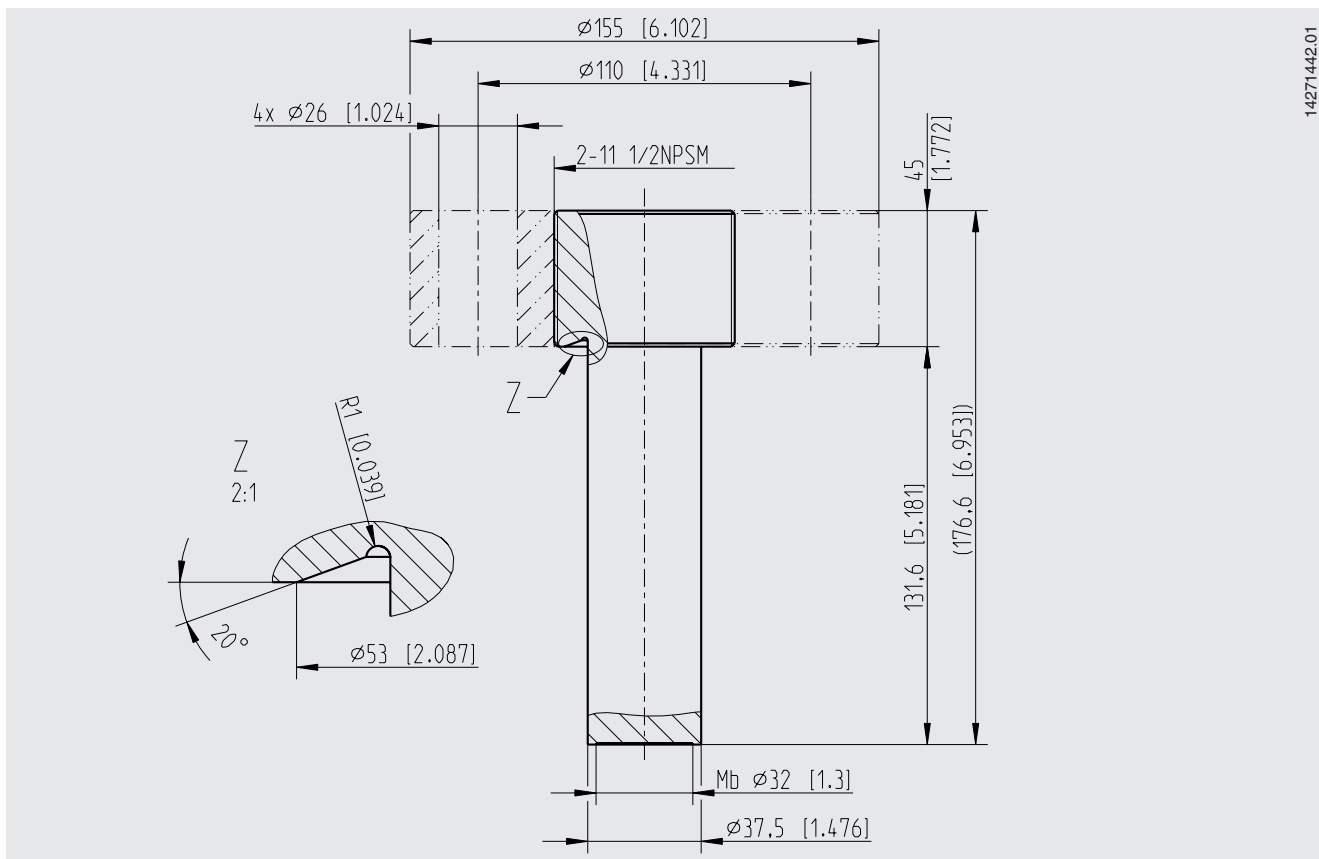

Other dimensions on request

Material design

Diaphragm seal	Maximum permissible process temperature ¹⁾ in °C [°F]
Stainless steel 1.4466 ²⁾	400 [752]

1) The maximum permissible process temperature is limited by the joining method and by the system fill fluid.
 2) Diaphragm material like 1.4466, however manganese content $\leq 4.5\%$ instead of $\leq 2\%$

Further material combinations on request

Certificates (option)

- 2.2 test report per EN 10204 (e.g. state-of-the-art manufacturing, material proof, indication accuracy for diaphragm seal systems)
- 3.1 inspection certificate per EN 10204 (e.g. material proof for wetted metallic parts, indication accuracy for diaphragm seal systems)

Approvals and certificates, see website

Ordering information

Diaphragm seal:

Diaphragm seal model / Process connection (standard, nominal width, nominal pressure) / Material / Level of cleanliness of wetted parts / Origin of wetted parts / Connection to the measuring instrument / Certificates

Diaphragm seal system:

Diaphragm seal model / Pressure measuring instrument model (per data sheet) / Mounting (direct mounting, cooling element, capillary) / Material / Min. and max. process temperature / Min. and max. ambient temperature / Vacuum service / System fill fluid / Certificates / Height difference / Level of cleanliness of wetted parts / Origin of wetted parts / Instrument mounting bracket / Process connection (standard, nominal width)

© 04/2018 WIKA Alexander Wiegand SE & Co. KG, all rights reserved.
The specifications given in this document represent the state of engineering at the time of publishing.
We reserve the right to make modifications to the specifications and materials.

Your WIKA Sales Partner



ICS Schneider Messtechnik GmbH

Briesestrasse 59
D-16562 Hohen Neuendorf / OT Bergfelde
Tel.: +49 3303 5040-66
Fax: +49 3303 5040-68
E-Mail: info@ics-schneider.de



WIKA Alexander Wiegand SE & Co. KG
Alexander-Wiegand-Straße 30
63911 Klingenberg/Germany
Tel. +49 9372 132-0
Fax +49 9372 132-406
info@wika.de
www.wika.de