

Top-mounted level indicator For level measurement in liquid media Model UTN

WIKA data sheet LM 11.02



for further approvals
see page 3

Applications

- Chemical, petrochemical, natural gas, offshore industries
- Shipbuilding, machine building
- Power generating equipment, power plants
- Pharmaceutical, food and beverage industries, process water and drinking water treatment

Special features

- Process- and procedure-specific production
- Operating limits:
 - Operating temperature: $T = -60 \dots +300 \text{ }^\circ\text{C}$
 - Operating pressure: $P = \text{Vacuum to } 40 \text{ bar}$
- Wide variety of different process connections
- Mounting of level sensors and magnetic switches possible as an option
- Explosion-protected versions

Description

The model UTN top-mounted level indicator consists of a measuring chamber, a float with guide rod and a magnetic system. Mounting onto the vessel is made via appropriate process connections (flange, thread).

The permanent magnetic system, which is connected to the float via a guide rod, transmits the liquid level measured in the vessel by the float, contact-free, to the magnetic display mounted to the outside of the measuring chamber. In this magnetic display there are red/white plastic rollers or stainless steel flaps with bar magnets fitted at 10 mm intervals. The magnetic rollers or flaps are turned 180° through the walls of the measuring chamber. For an increasing level from white to red; for a falling level from red to white. Thus the magnetic display indicates the level of a vessel as a red column, without power supply.



Top-mounted level indicator, model UTN

Further special features

- Simple, robust and solid design
- Measuring and indicating of the filling height of aggressive, combustible, toxic, hot, agitated and highly contaminated media
- Without power supply the functioning of the magnetic roller display is guaranteed even in the case of power failures
- Applicable for all industrial applications by using various corrosion-resistant materials

Options

The following optional instruments can be fitted to the outside of the UTN for indicating and controlling levels:

- Level sensors, models BLR, BLM
Level sensors are used as measured value pick-ups for the continuous detection of the level in connection with transmitters. They transform the resistance value of the level sensors into a standardised analogue signal that is proportional to the height of the level.
For further information on mounting, see operating instructions.
- Magnetic switch, model BGU
Magnetic switches serve to detect the limits of levels. They generate a binary signal which can be fed to down-stream signalling or control equipment.
For further information on mounting, see operating instructions.

Illustration of the principle

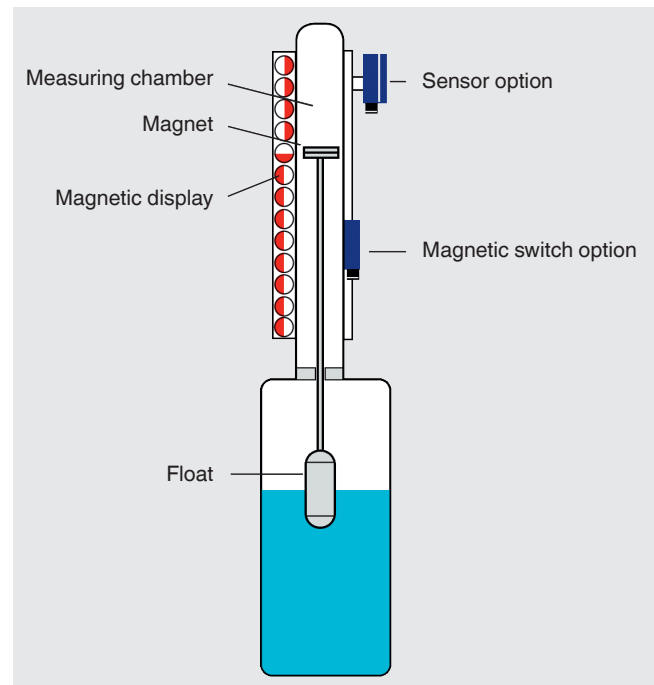

Design and operating principle

- In a measuring chamber mounted to the top of a vessel a magnet is located, which is connected to the float via a guide rod and moves with the level of the medium to be measured.
- The magnetic field of the radial-symmetric magnetic system activates the magnetic display attached to the outside of the measuring chamber as well as the switching and measuring elements.

Magnetic system

The magnetic system is assembled from a pole disc and various magnets. These can be individually adapted to the different chamber dimensions and for temperatures up to 300 °C.

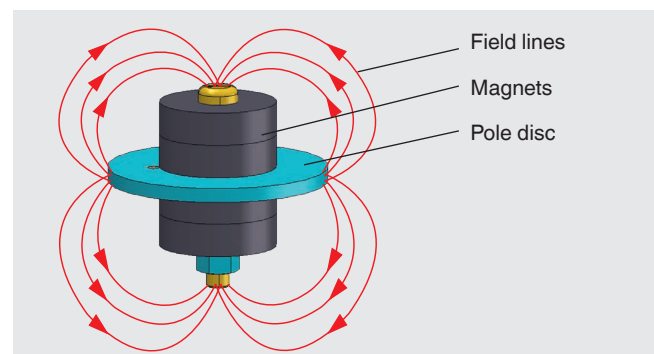

Model overview

Top-mounted level indicator model	Description	Material	Max. pressure in bar	Medium temperature in °C
UTN-C	42 mm version (standard)	Stainless steel 1.4571 (316Ti)	40	-120 ... +300
		Stainless steel 1.4401/1.4404 (316/316L)	40	-196 ... +300
UTN-S	60 mm version	Stainless steel 1.4571 (316Ti)	40	-120 ... +300
		Stainless steel 1.4401/1.4404 (316/316L)	40	-196 ... +300



Design codes available

- AD2000
- ASME B31.3
- EN 13445

CE classification

Model	DGRL	ATEX	CE
UTN-C00 UTN-S00	-	-	-
UTN-CA1, UTN-CA2, UTN-CBD, UTN-CGE, UTN-CBC UTN-SA1, UTN-SA2, UTN-SBD, UTN-SGE, UTN-SBC	x	-	x
UTN-C00C UTN-S00C	-	x	x
UTN-CA1C, UTN-CA2C, UTN-CBDC, UTN-CGEC, UTN-CBC UTN-SA1C, UTN-SA2C, UTN-SBDC, UTN-SGEC, UTN-SBC	x	x	x

Approvals

Logo	Description	Country
	EU declaration of conformity <ul style="list-style-type: none"> ■ Pressure equipment directive (option) ■ ATEX directive (option) Hazardous areas Ex c Zone 0/1, gas II 1G c T1 ... T6 or II 1/2G c T1 ... T6 <p style="text-align: right;">KEMA 02 ATEX 2106 X</p>	European Union
	EAC <ul style="list-style-type: none"> ■ EMC directive (in connection with mounted components) No. RU D-DE.A301.B.00815 ■ Pressure equipment directive No. RU D-DE.MJU62.B.02027 ■ Hazardous areas (option) No. RU C-DE.GB08.B.01489 	Eurasian Economic Community
	GOST (in connection with reed sensor) Metrology, measurement technology No. 19358	Russia

Approvals and certificates, see website

Top-mounted level indicator, 42 mm version (standard) Model UTN-C

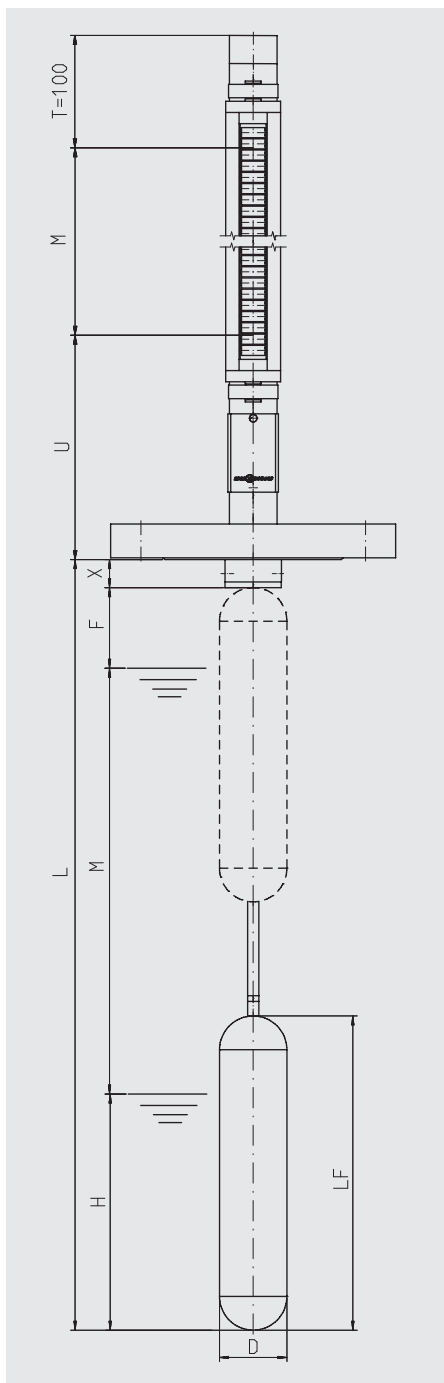

Specifications	
Measuring chamber	Ø 42.4 x 2 or Ø 42.2 x 2.77
Chamber end top	Flat top or pipe cap Options: Vent plug G 1/2"
Process connection	<ul style="list-style-type: none"> ■ Mounting thread G 2" ■ Mounting flange <ul style="list-style-type: none"> - DIN EN 1092-1: DN 50 ... DN 250, PN 6 ... PN 64 - ASME B 16.5: 2" ... 10", class 150 ... 600
Material	<ul style="list-style-type: none"> ■ Measuring chamber, process connection: Stainless steel 1.4571 (316 Ti), 1.4401/1.4404 (316/316L) ■ Guide rod: Titanium 3.7035 ■ Float: Stainless steel 1.4571 or titanium 3.7025 <p>other materials on request</p>
Nominal pressure	max. 40 bar
Temperature range	<ul style="list-style-type: none"> ■ 1.4571 (316 Ti): -120 ... +300 °C ■ 1.4401/1.4404 (316/316L): -196 ... +300 °C
Max. insertion length L	3,000 mm Other versions on request With large lengths and lateral flows, a stilling well is recommended.
Top stand-off T	Standard 100 mm
Bottom stand-off U	min. 140 mm
Guiding sleeve length X	min. 25 mm
Float	see table page 6
Magnetic display	Model BMD-SA: < 200 °C Model BMD-FA: > 200 °C For specifications, other versions and options see magnetic display for bypass level indicator, model BMD (data sheet LM 10.03)
Further options	<ul style="list-style-type: none"> ■ Magnetic switch: Model BGU, see data sheet LM 10.06 ■ Reed sensor: Model BLR, see data sheet LM 10.04

Top-mounted level indicator, 60 mm version Model UTN-S

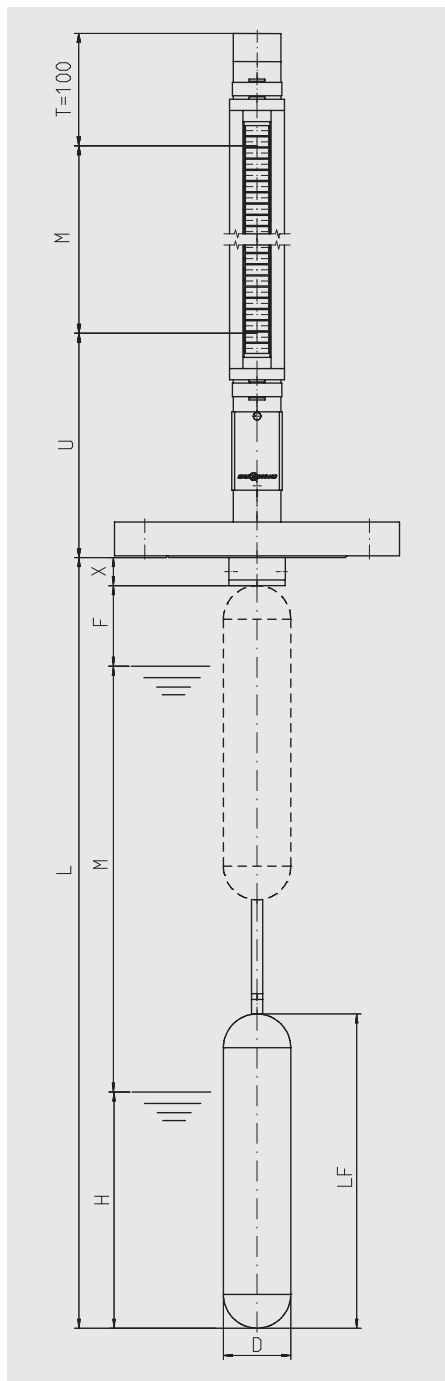

Specifications	
Measuring chamber	Ø 60.3 x 2 or Ø 60.3 x 2.77
Chamber end top	Flat top or pipe cap Options: Vent plug G 1/2"
Process connection	Mounting flange - DIN EN 1092-1: DN 50 ... DN 250, PN 6 ... PN 64 - ASME B 16.5: 2" ... 10", class 150 ... 600
Material	<ul style="list-style-type: none"> ■ Measuring chamber, process connection: Stainless steel 1.4571 (316 Ti), 1.4401/1.4404 (316/316L) ■ Guide rod: Titanium 3.7035 ■ Float: Stainless steel 1.4571 or titanium 3.7025 other materials on request
Nominal pressure	max. 40 bar
Temperature range	<ul style="list-style-type: none"> ■ 1.4571 (316 Ti): -120 ... +300 °C ■ 1.4401/1.4404 (316/316L): -196 ... +300 °C
Max. insertion length L	3,000 mm Other versions on request With large lengths and lateral flows, a stilling well is recommended.
Top stand-off T	Standard 100 mm
Bottom stand-off U	min. 140 mm
Guiding sleeve length X	min. 25 mm
Float	see table page 6
Magnetic display	Model BMD-SA: < 200 °C Model BMD-FA: > 200 °C For specifications, other versions and options see magnetic display for bypass level indicator, model BMD (data sheet LM 10.03)
Further options	<ul style="list-style-type: none"> ■ Magnetic switch: Model BGU, see data sheet LM 10.06 ■ Reed sensor: Model BLR, see data sheet LM 10.04 ■ Magnetostrictive sensor: Model BLM, see data sheet LM 10.05

Overview of floats

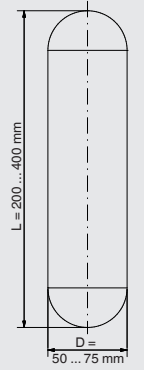
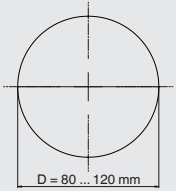
Float	Form	Material	Pressure range
	Cylinder (ZVS... / ZTS...)	Stainless steel 1.4571 or titanium	to 40 bar
	Ball (V... / T...)	Stainless steel 1.4571 or titanium	to 40 bar

Special versions on request

Float design according to process parameters density, pressure and temperature and insertion length L.

Ordering information

Model / Approval / Material / Process specifications (operating temperature and pressure, density) / Process connection / Insertion length L / Measuring range M / Stilling well / Options

© 08/2017 WIKA Alexander Wiegand SE & Co. KG, all rights reserved.
The specifications given in this document represent the state of engineering at the time of publishing.
We reserve the right to make modifications to the specifications and materials.